

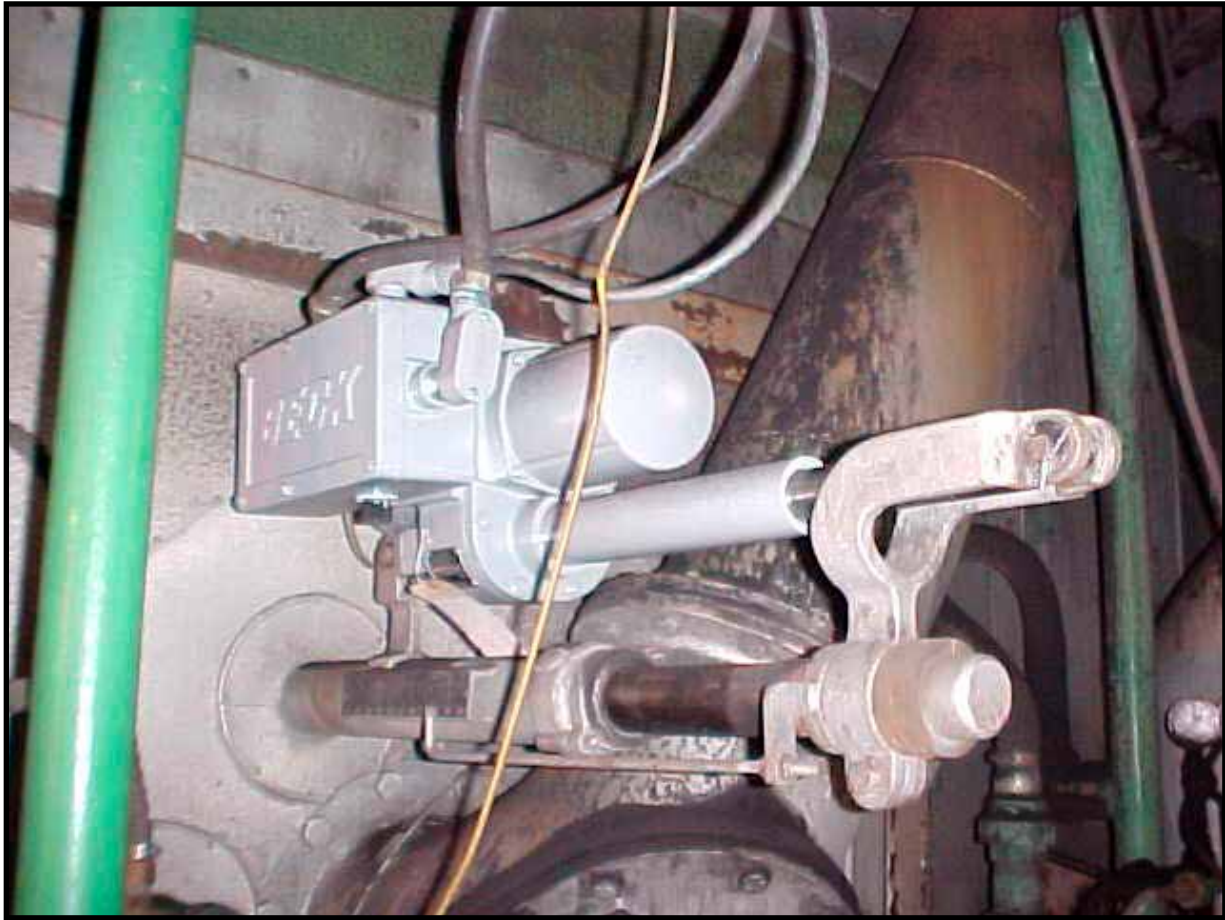

INSTRUCTION MANUAL

For actuators equipped with the
DCM-3 (built after July 2016)



INTRODUCTION

This manual contains the information needed to install, operate, and maintain Beck Model 42-109 Electric Actuators, manufactured by Harold Beck & Sons, Inc. of Newtown, Pennsylvania.

Group 42 actuators are powerful control packages designed to provide precise position control on long, linear stroke applications requiring up to 1,000 lbs. [4 450 N] of thrust.

NOTE: This manual includes information that will make installation simple, efficient, and trouble-free. Please read and understand the appropriate sections in this manual before attempting to install or operate your actuator.



The Group 42 actuator combines years of electric actuation experience with state-of-the-art technologies to provide all the performance and reliability customers expect from Beck actuators.

Designed for long linear stroke applications, the Group 42 offers simplicity, flexibility and an easy-to-use package. Ideally suited for burner air register type applications, the Group 42 is flexible and can be used on many long linear stroke applications.



Group 11 rotary actuators ... provide precise position control of dampers, quarter-turn valves, fluid couplings, and other devices requiring up to 8,000 lb-ft [10 839 N•m] actuator torque.



Group 11 quarter-turn actuators ... are designed specifically for use with ball, plug, and butterfly valves. Direct-coupled, factory-mounted assemblies are available from Beck for easy installation.



Group 22 digital control actuators ... are designed for accurate, reliable, digital control in high torque applications. The actuator is ideal for use in large boiler applications, such as ID/FD fan dampers.



Group 31 rotary actuators ... are particularly suited for coupling to ball, plug, and butterfly valves up to 4" diameter, and small dampers.

TABLE OF CONTENTS

General Specifications	4
Outline Dimension Drawings	5
Precautionary Information	6
General Operation Information	7
Installation	
Electrical.....	8
Wiring	10
Start-up	11
Components	
Mechanical	12
Electronic	13
Configuration / Calibration	17
Maintenance	32
Troubleshooting	38
Appendices	
HART® Communication.....	43
HART® Messages	50
Serial Communication.....	53
Serial Commands.....	54
Optional DCM-3 w/ Feedback Display	62
Index	62
Services	63

GENERAL SPECIFICATIONS

Actuator Power	120 V ac, single-phase, 60 Hz (Standard), 50 Hz (Optional) 208, 240, 380, 415, 480 & 575 V ac, 50 or 60 Hz (Optional)	Allowable Tolerance	+10%	-15%			
Maximum Current (Amps) by Supply Voltage							
Voltage (V ac)							
Maximum Power (W)	120	208	240	380	415	480	575
144	1.2	0.69	0.60	0.38	0.35	0.30	0.25
Output Thrust and Timing	1,000 lbs. [4450 N], 4.2 sec/in [1.65 sec/cm]						
Stroke Range	5 to 18 inches [127 to 457 mm]						
Weight	Approx. 75–89 lbs. [34–40 kg], depending on selected options						
Operating Conditions	-40° to 185°F (-40° to 85°C) 0 to 100% relative humidity, non-condensing						
Communication Interface	HART protocol (Rev. 5 -- burst mode is not supported), local pushbutton/LEDs and DB9 Serial commands.						
Demand Input Signal Range	4–20 mA, 1–5 V dc						
Minimum Step	0.1% of span						
Hysteresis	0.25% of span at any point						
Demand Input Signal Characterization	Linear: Actuator output shaft moves proportionally to the input signal. Square: Actuator output shaft moves proportionally to the square of the input signal. Custom: 20 segment configurable curve fit.						
Position Feedback Signal	4–20 mA						
Isolation	Demand input and position Feedback signals are isolated from ground and the ac power line. Signal buffering provides 24 V dc isolation between the Demand and Feedback signals.						
Action on Loss of Power	Output shaft stays in last position.						
Action on Loss of Input Signal (Power on)	Stay in place or runs to any preset position (configurable).						
Over-thrust Protection	If the output thrust of the actuator exceeds 150% of the actuator rating, the motor will shut off (feature can be enabled/disabled).						
Stall Protection	If the motor tries to run in one direction for more than 300 seconds (configurable from 30 to 300 seconds), the motor will shut off.						
Over-travel Limit Switches	Two Form C (Retract and Extend) provide over-travel protection. Rated 10 A, 125/150 Vac; .5 A, 125 Vdc; .25 A, 150 Vdc.						
Aux. Switches (field adjustable)	Two Form C rated 10 A, 125/150 Vac; .5 A, 125 Vdc; .25 A, 150 Vdc.						
Handswitch	Permits local electrical operation, independent of Demand input signal.						
Handwheel	Provides manual operation without electrical power.						
Motor	120 V ac, single-phase, no burnout, non-coasting. Capable of 60 starts per minute.						
Enclosure	Precision-machined aluminum alloy, painted with corrosion-resistant polyurethane paint, to provide a rugged, dust-tight, weatherproof enclosure. Type 4X; IP66.						
Mounting Orientation	Can be mounted in any orientation.						
Hazardous Location Options for Dust Area Classifications	Available options approved for use in: <ul style="list-style-type: none"> • Class II, Division 1, Groups E, F and G; T3C • Class II, Division 2, Groups F & G; T3C • Class III, Division 1 & 2 Tambient = -30°C to 70°C (120V); -30°C to 60°C (240V)						

OUTLINE DIMENSION DRAWINGS

RIGHT SIDE VIEW

All dimensions are in inches & [mm] and are subject to change

Note:
 Front mounting clevis rotates 360°.
 Custom clevis diameters are available.
 Custom rear clevis extensions are available.

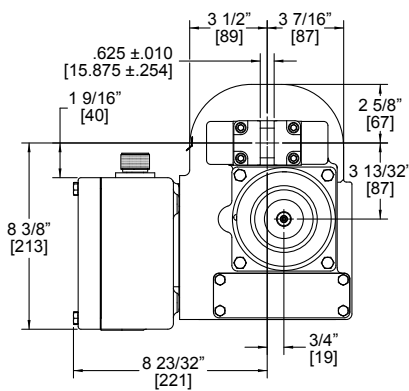
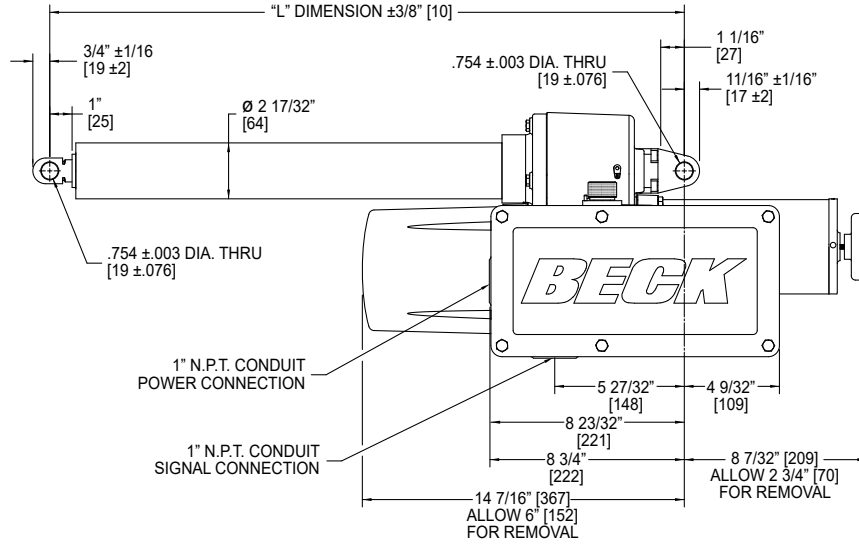

REAR VIEW

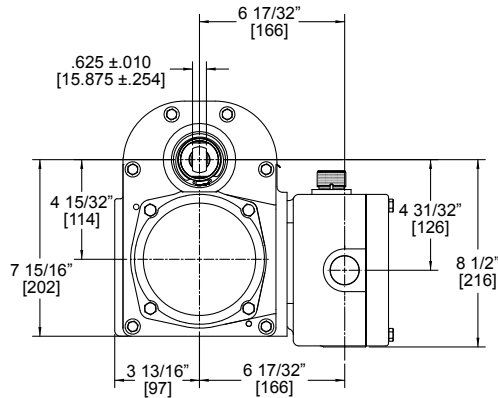

FRONT VIEW

208, 240, 380, 415, 480 & 575 VOLT POWER VERSION

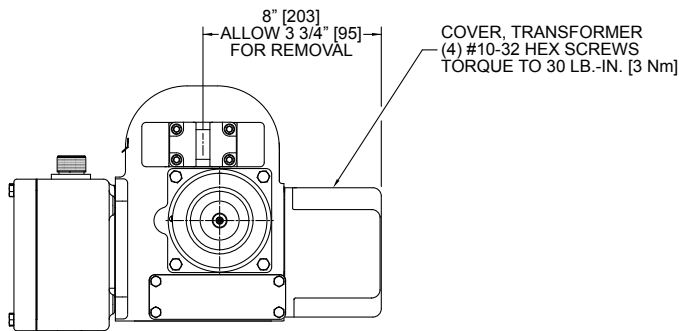

REAR VIEW

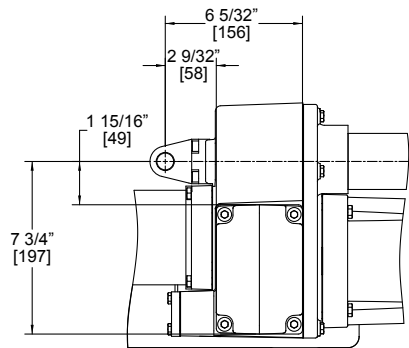

PARTIAL LEFT SIDE VIEW

Max. Actuator Travel (in) [mm]	Min. Actuator Travel (in) [mm]	"L" Dim. Fully Retracted (in) [mm]	"L" Dim. Fully Extended (in) [mm]	Approx. Wt. 120 Volts (lbs) [kgs]	Approx. Wt. 240 Volts (lbs) [kgs]
8 [203]	5 [127]	18 19/32 [472]	26 19/32 [675]	75 [34]	84 [38]
12 [305]	7 [178]	22 19/32 [574]	34 19/32 [879]	77 [35]	86 [39]
18 [457]	11 [279]	28 19/32 [726]	46 19/32 [1183]	80 [36]	89 [40]

PRECAUTIONARY INFORMATION

SAFETY PRECAUTIONS



WARNING

Installation and service instructions are for use by qualified personnel only. To avoid injury and electric shock, do not perform any servicing other than that contained in this manual. Please read and understand the appropriate sections in this manual before attempting to install or operate your actuator.

STORAGE INFORMATION

Beck actuators should be stored in a clean, dry area where the temperature is between -40° and 85°C (-40° to 185°F).

Damage due to moisture while in storage is not covered by warranty.

INSTALLATION—ELECTRICAL

See the instructions beginning on page 9 for details regarding electrical installation.



CAUTION

For maximum safety, the Beck actuator body should be grounded. Use the green grounding screw in the wiring compartment of the actuator.



CAUTION

Always close covers immediately after installation or service to prevent moisture or other foreign matter from entering the actuator.

CONDUIT ENTRIES

Conduits are provided for power and signal wiring. Temporary plugs are installed in the conduit entrances at the factory for shipping only and are not intended for permanent use. Prior to actuator operation, all conduit entrances must be properly sealed in accordance with National Standards or Regulatory Authorities.

GENERAL OPERATION INFORMATION

MODES OF OPERATION

There are three basic modes of operation:

- **Handwheel**—local mechanical control
- **Handswitch**—local electrical control
- **Automatic**—remote electrical control

Any or all of these modes can be used to test basic operation of your actuator during start-up.

HANDWHEEL

The Handwheel permits manual operation of the actuator without power. The Handwheel is coupled directly to the motor shaft at the rear of the motor housing and it rotates when the motor runs.

The Handwheel is particularly useful during initial installation or when power is not available. If power is available, the Handswitch must be moved to the STOP position before manually operating the Handwheel.

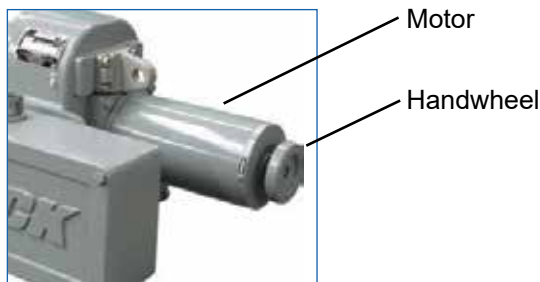

HANDSWITCH

A Handswitch allows local electric control at the actuator. In either of the STOP positions, the motor is blocked from running. In the RETRACT or EXTEND positions, the motor runs to move the output shaft in the corresponding direction. When moving the output shaft using the Handswitch, the motor will stop when the over-travel limit switches are reached.



The Demand signal can position the actuator only when the Handswitch is in the AUTO position.

AUTOMATIC MODE

When the Handswitch is placed in the AUTO position, the actuator is in automatic mode and responds to a Demand signal (also called the setpoint). The Digital Control Module (DCM-3) compares the Demand signal with the output shaft position. When the DCM-3 detects a difference between Demand and Position (called error), the motor will move the output shaft until the Position matches the Demand.

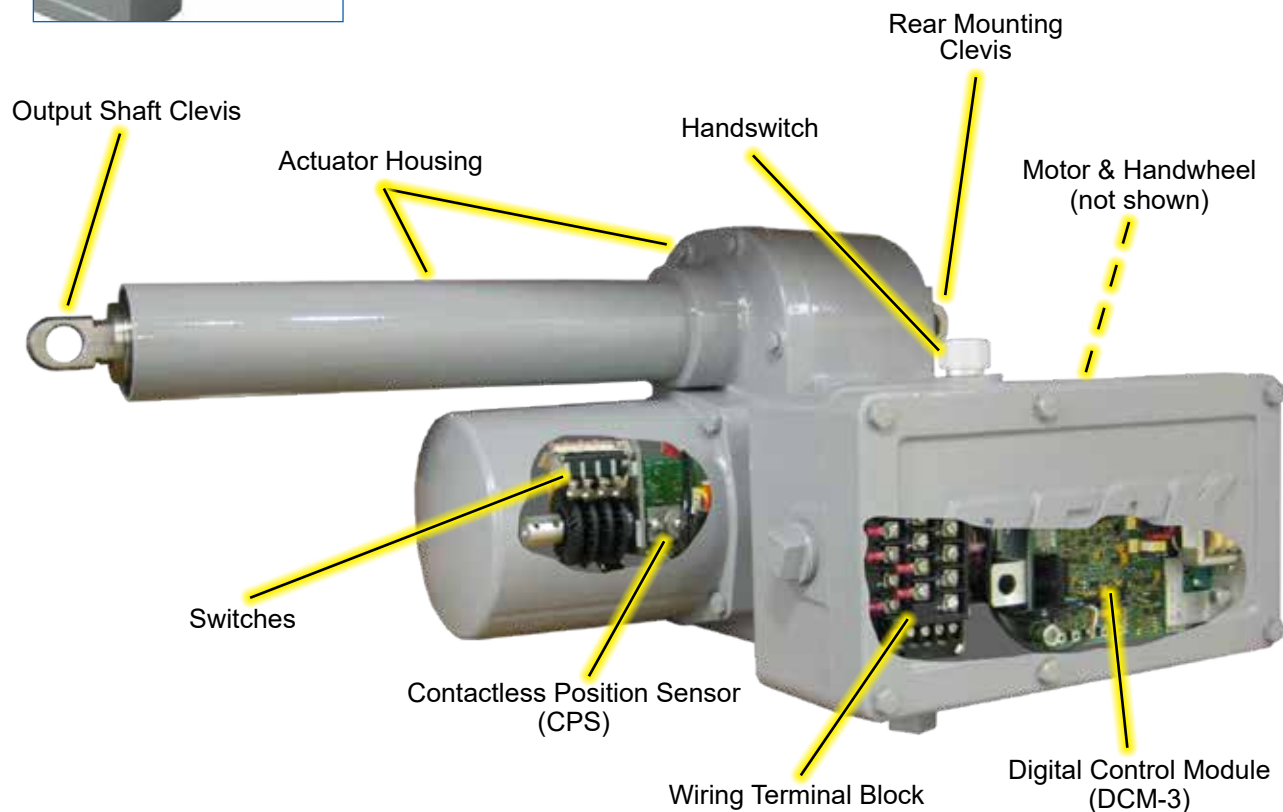

42-109 Cutaway View

NOTE: Layout may vary slightly depending on DCM version.

INSTALLATION *Electrical*

POWER QUALITY

Power quality disturbances such as power outages, transient voltages, harmonic distortions, and electrical noise will adversely affect your actuator performance. Protecting your actuator from these conditions can reduce downtime and promote longer life for the equipment. Following the industry accepted standards below will help protect your actuator.

- ✦ Select wiring materials according to the correct ampacity ratings dictated by national and local regulations.
- ✦ Shielded, twisted pair cables can be used for signal connections to avoid being affected by electrical noise. These signal wires, based on Noise Susceptibility Level (NSL) per IEEE-518, fall into the level 1 classification. A braided shield will be more effective than a wrapped foil shield. Signal wire shields should be connected to the actuator casting grounding screw. If grounding at the signal source is required, then the shield should not be grounded at the actuator.
- ✦ Raceways such as conduits and trays must be grounded at both ends to properly meet immunity requirements.
- ✦ An AC power ground connection should be made between the power source and the Beck actuator. Grounding connections including wire and metal conduit are permitted, but the actuator-grounding conductor may not be connected to a structured metal frame of a building.
- ✦ Surge suppression equipment that meets Underwriters Laboratory (UL) Standard 1449 may be used to protect against transient voltage conditions.
- ✦ Power Conditioners may be used to regulate the supply voltage and maintain a constant voltage level. They are helpful in protection against voltage sags and swells, as well as some measure of electrical noise protection.
- ✦ Harmonic filters may be used to minimize the effects of supply voltage waveform distortions and are used in applications that incur a large amount of high-frequency electronic noise.



CAUTION

Always close covers immediately after installation or service to prevent moisture or other foreign matter from entering the actuator.

ELECTRICAL INSTALLATION

Two conduit connections are provided for supplying power and signal wiring to the unit. Conduits should be routed from below the actuator so that condensation and other contaminants flow away from the conduit. All conduit entrances must be properly sealed in accordance with National Standards or Regulatory Authorities.

To maintain signal integrity and meet most electrical codes, power and signal wires must be routed to the actuator separately. The signal wiring should be either shielded cables or be installed in conductive conduit and/or cable trays.

A large, clearly labeled terminal block is enclosed in a gasketed metal enclosure (see illustration on page 7). Terminals will accommodate up to 12 AWG (3.31 mm²) wiring (see figure on page 9).



CAUTION

Always close covers immediately after installation or service to prevent moisture or other foreign matter from entering the actuator.

Refer to the wiring diagram furnished with your Beck actuator for proper AC power and signal connections. It is advisable to provide normal short circuit protection on the AC power line. A copy of the wiring diagram is shipped with each actuator and is fastened to the inside of the terminal block cover. If there is no wiring diagram available, you may obtain a copy from Beck by providing the serial number of your actuator.

Your Beck actuator has been supplied to match the signal source in your control loop. If it does not match, the input signal range is convertible by adding or removing a 250 ohm resistor—contact the factory for details.

For maximum safety, the Beck actuator body should be grounded. Normally, the electrical conduit provides adequate ground protection. If not, a separate ground conductor should be connected to the actuator body.

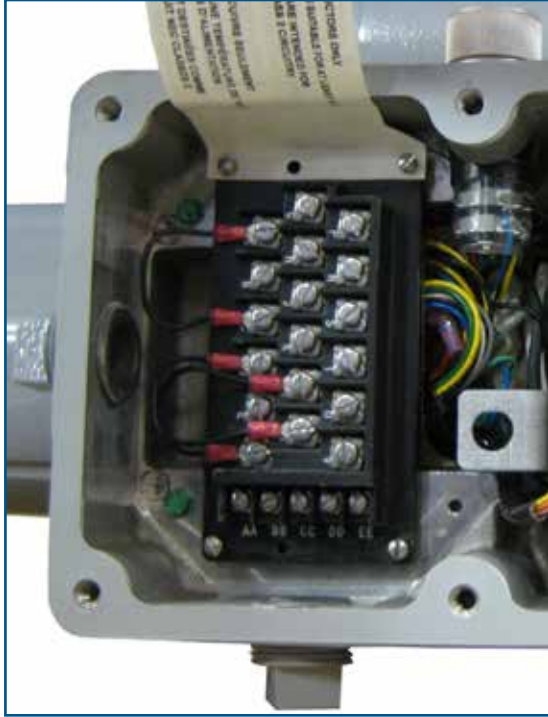

TERMINAL BLOCK LOCATED WITHIN THE
WIRING / DCM-3 COMPARTMENT

Three additional terminals and fuse (F1) are provided with 3-phase power options.

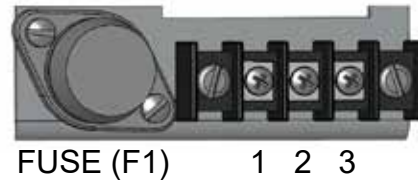

TERMINAL SCREW TORQUES

Each terminal screw should be torqued to the proper specification upon landing the wire.

<i>Models</i>	<i>Terminals</i>	<i>Torque</i>	
		<i>(lb-in)</i>	<i>(N•m)</i>
All Models	A-V	16	1.8
	AA-EE	12	1.4
	1-3*	9	1.0

*Terminals included only with certain optional features.

INSTALLATION Wiring

TYPICAL WIRING CONNECTIONS (120 V Power, Single-phase)

POWER AND DEMAND INPUT CONNECTIONS
 Customer must supply appropriate voltage to the proper terminals (as depicted in the appropriate wiring diagram provided) to power the actuator and control circuitry. Input signal wires connect to terminals AA (+) and BB (-).

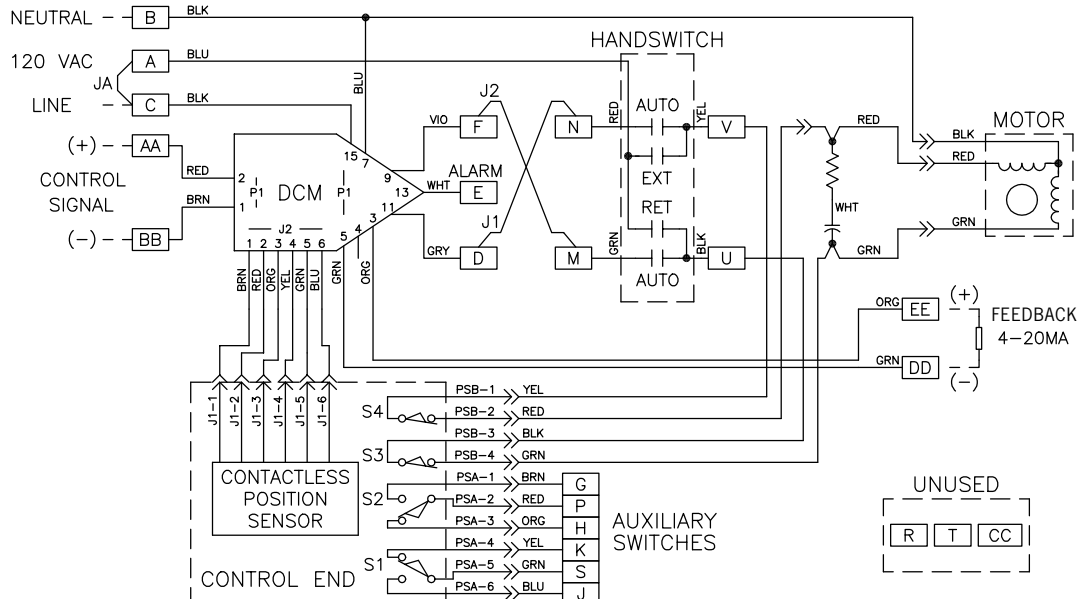

(240 V Power, Single-phase)

Alternate Power Options (3-phase)

(208/240 V Power)

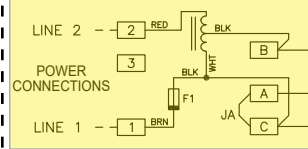

(380/415/480/575 V Power)

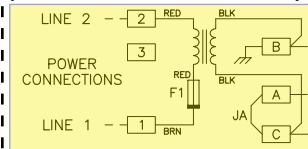

Same as 240 V Single-phase, except where highlighted.

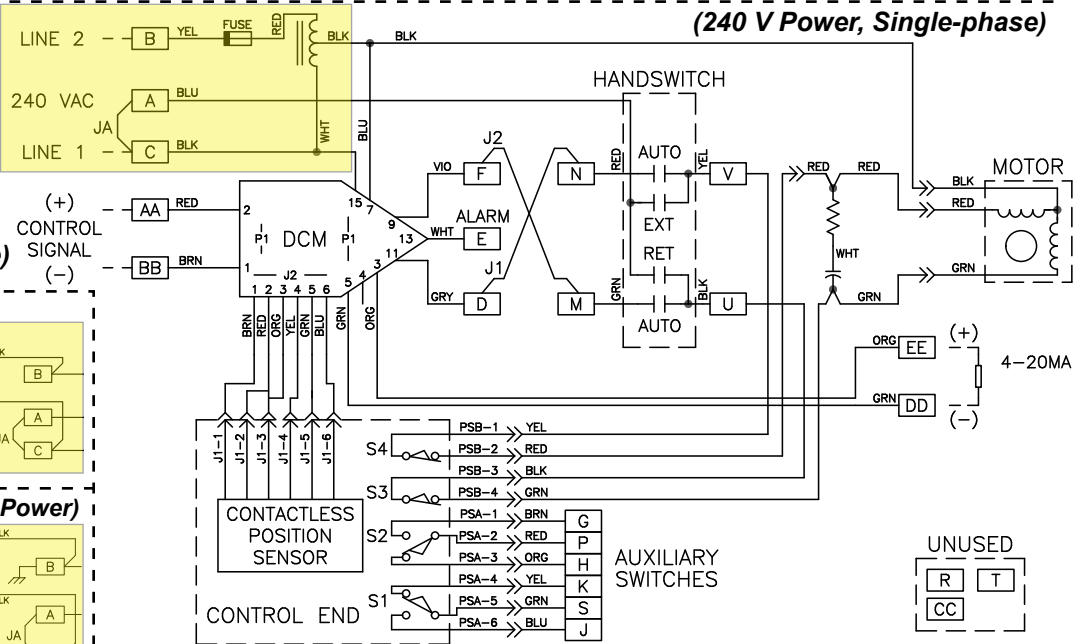

Wiring connections with optional DPDT Relay Assembly installed on terminal block.

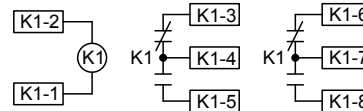

TERMINAL BLOCK CONFIGURATION JUMPERS

	J1	J2	J4	J5	J6	J7	J8	J9	J10	J11
<input type="checkbox"/> Standard	D-N	F-M								
<input type="checkbox"/> Status Alarm Contact	D-N	F-M							B-K1-1	E-K1-2
<input type="checkbox"/> Ext on Relay Action	D-K1-3	F-K1-6	N-K1-4	M-K1-7	C-K1-5					
<input type="checkbox"/> Ret on Relay Action	D-K1-3	F-K1-6	N-K1-4	M-K1-7	C-K1-8					
<input type="checkbox"/> Stop on Relay Action	D-K1-3	F-K1-6	N-K1-4	M-K1-7						
<input type="checkbox"/> Int on Relay Action	D-K1-3	F-K1-6	N-K1-4	M-K1-7	C-S	S-P	<input type="checkbox"/> J-K1-8	<input type="checkbox"/> G-K1-5		
							<input type="checkbox"/> K-K1-8	<input type="checkbox"/> H-K1-5		

NOTE: Intermittent position on relay action requires special S1 and S2 operation points to give proper position.

START-UP

START-UP

NOTE: All Beck actuators are shipped from the factory ready for installation. Each actuator is set-up and calibrated to the customer's specifications that were written into the equipment order. Electrical adjustments are generally not required before placing the actuator in operation.

START-UP CHECKLIST

The following list provides some basic checks that should be performed before placing your actuator into operation.

- Inspect the location and the mounting bolts. Be sure the actuator is securely fastened to its mounting base.
- On the first start-up, place the Handswitch in a STOP position to ensure that the output shaft will not move and possibly cause personal injury.
- Confirm the actuator is receiving the appropriate operating voltage as shown on the nameplate.
- Check the DCM-3 Power LED. It should be pulsing (Dim/Bright) to indicate the board is active.
- Using the Handswitch, confirm the actuator moves fully to both the EXT and RET ends of travel.
- Confirm the actuator has a 4–20 mA Demand signal attached to terminals AA (+) and BB (–).
- Place the Handswitch in AUTO and vary your Demand signal from 0% to 100%.
- Check for the Status alarm LED on the DCM-3. If it is lit, refer to the Troubleshooting section of this manual.
- Verify that the output shaft is moving to the desired 0% position with a 0% Demand signal and moving to the 100% position with a 100% Demand signal. If they are reversed, see the Configuration/Calibration section of this manual for instructions on how to change the direction of output shaft rotation.

COMPONENTS Mechanical

HOUSING

Beck Group 42 actuators have individual cast aluminum compartments for the main components: The control motor, wiring terminal block/DCM, drive train and control end. Gasketed covers and sealed shafts make the actuators ideally suited to outdoor and high humidity environments.

Heavy cast mechanical stops built into the housing are designed to prevent accidental over-travel damage during manual cycling, and ensure that proper orientation is maintained between the output shaft and the feedback system. Actuator travel is centered between the mechanical stops unless otherwise specified at time of order.

CONTROL MOTOR

The Beck control motor is a synchronous inductor motor which operates at a constant speed of 72 RPM in synchronism with the line frequency. Motors are able to reach full speed within 25 milliseconds and stop within 20 milliseconds; actual starting and stopping times will vary with load. Beck motors have double grease-sealed bearings and require no maintenance for the life of the motor.

DRIVE TRAIN

The drive train consists of the control motor, Handwheel, reduction gears, main gear and output shaft. The output shaft is limited by mechanical stops to 1/8" beyond the maximum stroke range.

SELF-LOCKING MECHANISM (SLM)

An integral part of every control motor is the self-locking mechanism. This mechanical device couples the motor to the gear train and transmits full motor torque when rotated in either direction. When the motor is de-energized, the SLM instantaneously locks and holds the output shaft in position.

HANDWHEEL

Every Beck actuator is furnished with a Handwheel to permit manual operation of the driven element without electrical power. Its solid construction design includes no spokes or projections, and turns at a safe, slow speed. The Handwheel is located at the rear of the control motor housing. The Handwheel is coupled directly to the motor shaft and rotates when the motor runs. Manual operation of the Handwheel (with electric Handswitch in "STOP" position) turns the motor and the rest of the actuator train without incorporating a clutch.

HANDSWITCH

A local electric Handswitch is provided on Beck actuators to permit operation independent of the controller. As a safety feature, the Handswitch is designed so that the controller can operate the actuator only when it is in the "AUTO" position. The sequence of the Handswitch is: "AUTO", "STOP", "RETRACT", "STOP", "EXTEND".

In the "AUTO" position, two contacts are closed and the DCM-3 completes the control circuit. In the "RETRACT" or "EXTEND" positions, contacts are closed to operate the actuator independently of the controller. In the "STOP" position, all contacts remain open.

SWITCHES

Two over-travel limit switches and up to two optional auxiliary switches are provided on Beck actuators. Switch cams are clamped onto the control shaft which rotates in relation to the output shaft. Cam position is field-adjustable. Switches are rated 10 A, 125 V ac. All auxiliary switch connections are made on the terminal block.

COMPONENTS Electronic

CONTACTLESS POSITION SENSOR (CPS-4)

The CPS provides the DCM-3 with a continuous feedback signal proportional to the position of the actuator's output shaft.

The position sensing function of the CPS is provided by a ferrite magnetic sensing element. An electronic circuit translates the signal from the ferrite magnetic sensor into a position signal used by the DCM-3 to control the actuator. The typical output voltage of the CPS ranges from ~1.0 V at the Extend end of travel, to ~4.0 V at the Retract end of travel. A 4–20 mA position feedback signal is available for remote position indication. If the CPS Position signal to the DCM-3 is out of the calibrated range limits, the "STAT" and "POSITION" LEDs will light. Alarm indication is available at terminal E .

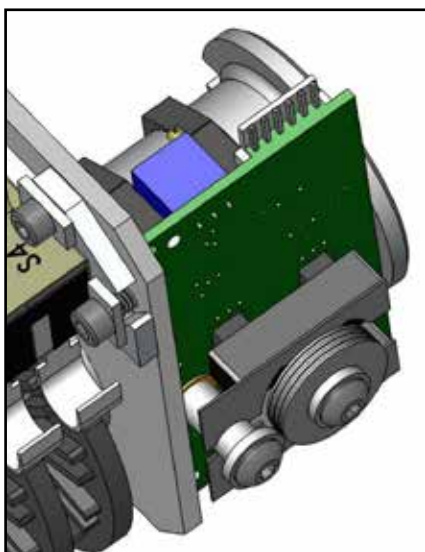

CPS-4

DIGITAL CONTROL MODULE (DCM-3)

The DCM-3 is a micro-processor based circuit board assembly that serves as the actuator's control center.

The main function of the DCM-3 is to position the actuator's output shaft. The DCM-3 compares the 4–20 mA Demand signal received at the actuator terminals AA(+) and BB (-) to the actuator position signal, generated from the Contactless Position Sensor (CPS-4). If a difference exists (called error) between the Demand and Position signals, the DCM-3 activates triacs that operate the motor. The motor actuates the gear train and positions the output shaft until the difference is eliminated.

The DCM-3 layout is shown on page 15 and includes the fuse and test point locations. The typical position signal voltage from the CPS-4 (measured from TP1(-) and TP4(+)) ranges from 1.0 V dc at the Extend end of output shaft travel, to 4.0 V dc at the Retract end of output shaft travel. Test point voltage levels between TP2(+) and TP3(-) across the input resistor R11 should read between 1 V dc and 5 V dc proportional to the 4–20 mA Demand signal.



DCM-3

NOTE: Layout may vary slightly depending on DCM version.

COMPONENTS *Electronic*

INTERFACES

The DCM-3 has three configuration interfaces: Pushbutton, HART, and Serial Port.

PUSHBUTTON

The DCM-3 board is equipped with pushbuttons that can be used to calibrate the Demand signal and configure 0% and 100% positions. It may also be used to configure the direction of output shaft travel for increasing Demand. These configurations and calibrations do not require any external equipment.

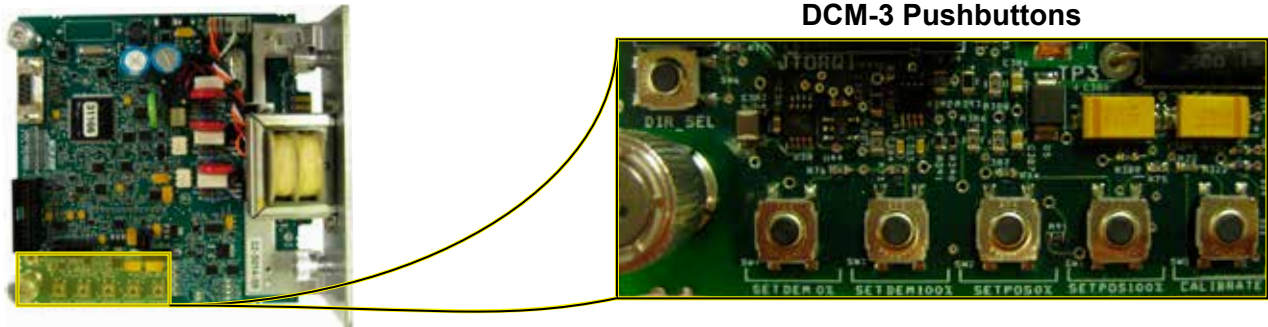

HART

The HART interface is accessible by connecting a HART capable communication device (such as a handheld communicator) to terminals AA (+) and BB (-) of the terminal block area. A HART-capable, analog output can be used for the Demand signal as well. All electronic calibration and configuration can be accomplished through the HART interface. NOTE: The appropriate HART device descriptions are required.

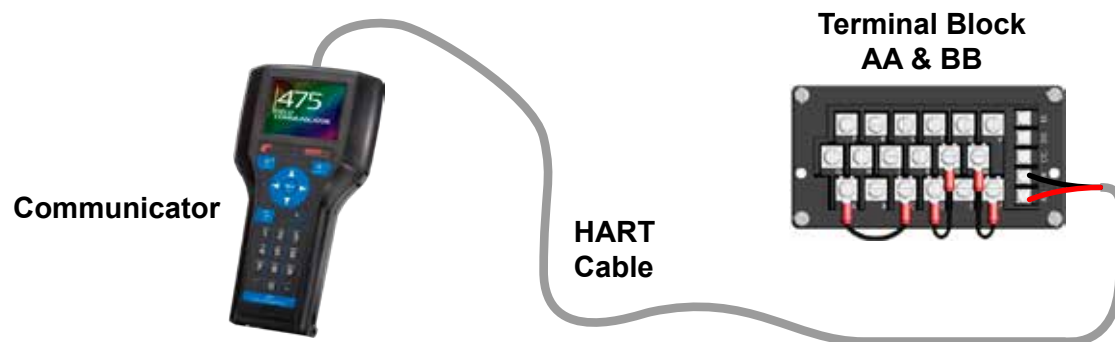

SERIAL PORT

The Serial port interface is accessible by connecting a computer to the DCM-3 using the DB9 connector. See the Serial Communications appendix for details on connecting via the Serial port. All electronic calibration and configuration can be accomplished through the Serial port interface.



DCM-3 LAYOUT

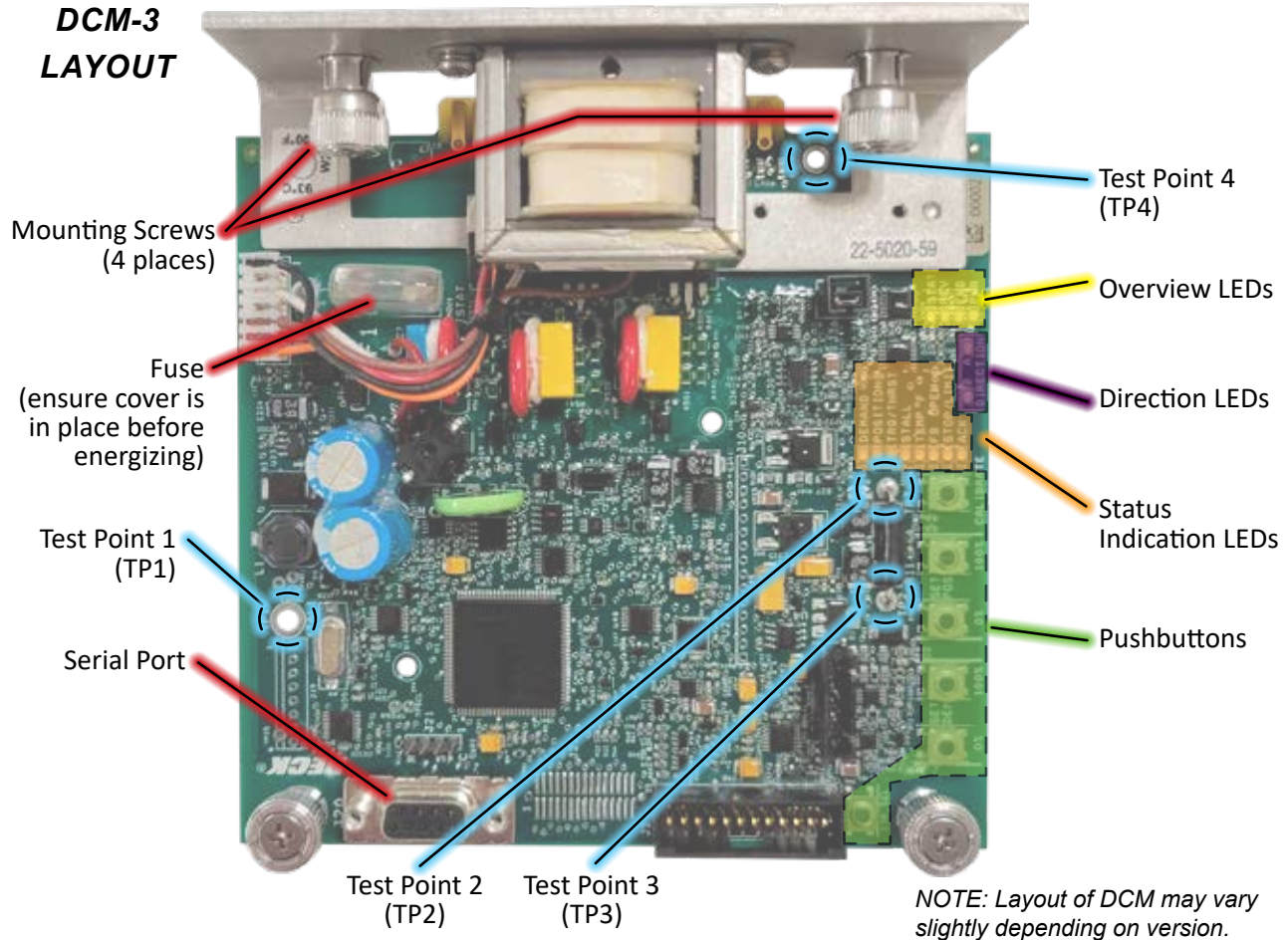

OVERVIEW LEDs

Located on the DCM-3 board (pictured above), these LEDs indicate the basic, real-time state of the actuator. A description of each LED follows.

STAT

This red LED illuminates during a system alarm. Explanation of the specific alarm is available through the Fieldbus or Serial interface. See the Troubleshooting section for additional information.

REV

This green LED illuminates when the actuator is receiving a Demand signal less than its position.

FWD

This green LED illuminates when the actuator is receiving a Demand signal greater than its position.

PWR

This green LED illuminates when power is applied to the actuator. This LED pulses from bright to dim indicating the DCM-3 is operational.



DIRECTION LEDs

These green LEDs indicate the direction of travel resulting from an increasing Demand signal.



A = RET B = EXT

COMPONENTS *Electronic*

STATUS INDICATION LEDS

When the "STAT" LED is lit, the applicable red indication LED(s) will light to reveal the actuator condition(s). An alarm is also available at terminal E. When the condition is corrected, the status will automatically reset.

DEMAND

Loss of the Demand input signal.

POSITION

The Position signal to the DCM-3 is out of the calibrated range limits. The lower limit is -5% and the upper limit is 105% of the calibrated range. May also indicate a film potentiometer or internal wiring failure.

TRQ/THRST

Indicates thrust has exceeded 150% of drive rating (configurable).

STALL

The actuator is in a stall condition and stall protection has been activated.

TEMP °F.

Actuator's internal temperature is outside of rating.

FB OPEN

External position Feedback signal is enabled, but not wired to an external load or the wiring has failed between the actuator and the monitoring device.

STOP/LIMIT

Handswitch is in "STOP" position or the actuator is at a limit and is not in balance.

ACK

Acknowledges when a calibration procedure has been completed.



PUSHBUTTON CONTROLS

The five pushbuttons (pictured below) on the DCM-3 customer interface panel are used for calibration. When pressing a pushbutton, pressure should be maintained until the "ACK" LED is lit; this confirms receipt of the pushbutton command. See the Configuration/Calibration section of this manual for further explanation of calibration procedures.

CALIBRATE

This button must be pressed and held simultaneously with another pushbutton to perform a calibration.

SET POS 100%

Press to designate the current position of the output shaft as the 100% position for actuator movement (this will correspond to a 100% Demand signal).

SET POS 0%

Press to designate the current position of the output shaft as the 0% position for actuator movement (this will correspond to a 0% Demand signal).

SET DEM 100%

Press to designate the current Demand input signal as 100% Demand.

SET DEM 0%

Press to designate the current Demand input signal as 0% Demand.

DIR SEL

Press to change the direction in which the output shaft will rotate in response to an increasing Demand signal. The opposite direction LED will light when the pushbutton command is confirmed.

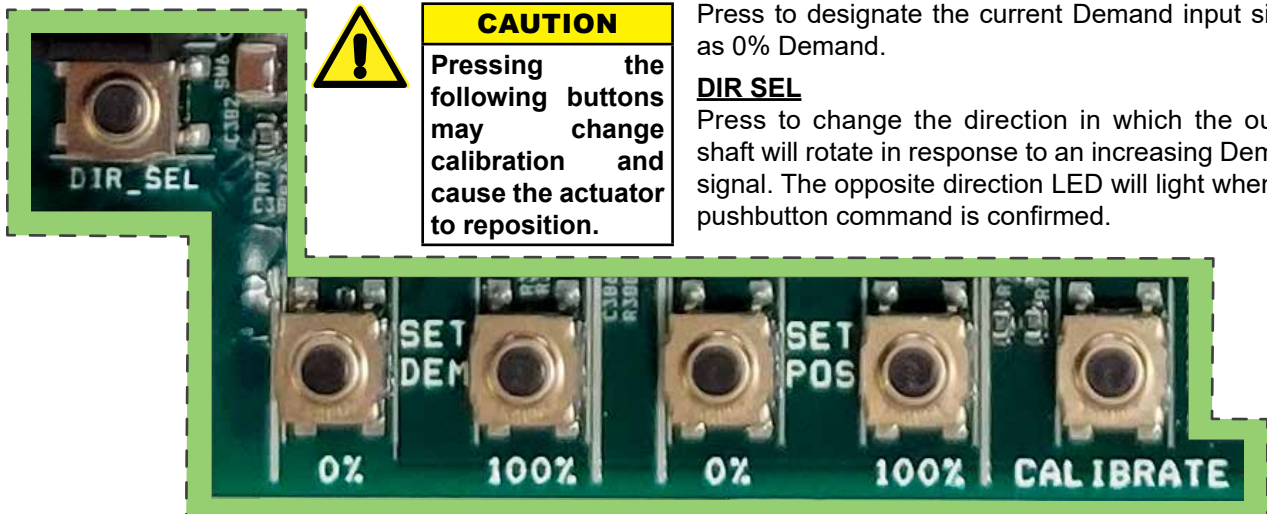

CONFIGURATION/CALIBRATION

All Beck actuators are shipped completely calibrated to the customer's specifications that were written into the equipment order and are ready to be installed. If the need arises to change the actuator calibration, first confirm that the actuator is installed as specified and operating properly before proceeding with the change.

Position reference and Demand calibration are performed using the DCM-3 customer interface panel, but may also be configured using the HART or Serial interface. Calibration of over-travel limit and auxiliary switches must be performed using the procedure beginning on page 18.

CALIBRATION PRIORITY

Group 42 actuators are equipped with fixed, non-adjustable, built-in mechanical stops. All output shaft movement must occur within these stops, which are approximately 1/8" beyond each end of maximum stroke range.

The over-travel limit switches are used to limit the electrical control range of the actuator. These switches are cam operated and are set slightly wider apart than the actuator's intended full range of electronic operation. The limit switches are positioned to provide an electrical overtravel protection.

If the actuator is short-stroked—i.e., full travel is reduced to less than the standard span—it may be desirable to reset the over-travel limit switches (see page 18). If the limit switches are not reset, Handswitch operation of the actuator (Retract, Extend) will still result in the original full range of travel. It is best to calibrate the actuator and then set the limit switches when short-stroking the actuator. The switches should be set just outside the calibrated range to avoid tripping the switch at the 0% and 100% positions.

The auxiliary switches are also cam operated, but have no affect on actuator and DCM-3 operation. Therefore, the auxiliary switches can be adjusted at any time without affecting performance or calibration.

CONFIGURATION/CALIBRATION

SWITCH CALIBRATION

NOTE: All Beck actuators are shipped from the factory ready for installation; no electrical adjustments are required before placing them in operation. Each actuator is set up and calibrated to the customer's specifications that were written into the equipment order.

Under normal operating conditions there is no need to recalibrate the actuator. However, if the application requirements change or are different than specified on the equipment order, the actuator should be recalibrated according to the following procedures.

Switch Adjustments

All control actuators are shipped with over-travel limit switches factory-set just outside the range of travel (unless otherwise specified at time of order). The switches are set to provide electrical over-travel protection. The switches must be set inside the range of the built-in mechanical stops. The switches can be reset to accommodate limited travel of the output shaft. Auxiliary switches are factory set, as shown in the illustration below, unless otherwise specified at time of order.

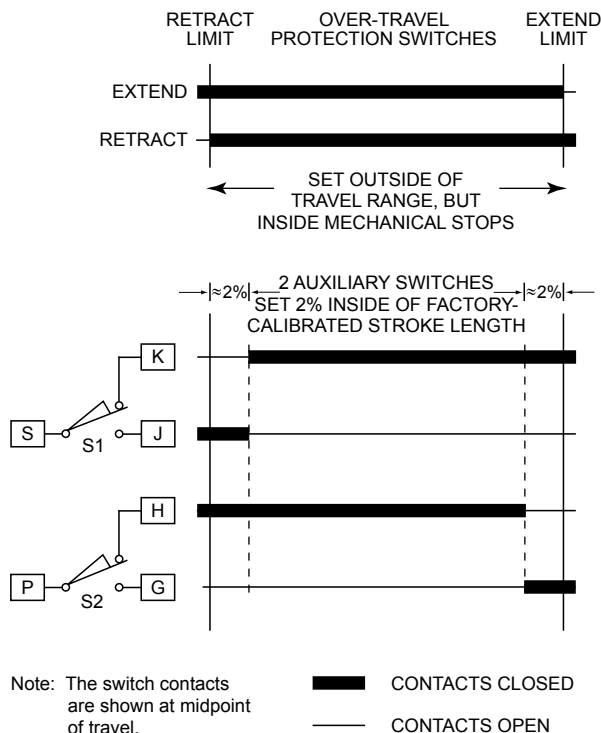

Standard Over-travel Protection and Auxiliary Switch Settings

Switches are operated by cams which are clamped onto the control shaft. Setting a switch involves moving the actuator's output shaft to the desired position and positioning the cam so that it operates the switch at that point. In the following procedure, the use of a continuity meter is recommended to determine when the switch opens or closes. If such a meter is not available, it is possible to hear the switch click as the contacts open and close.



CAUTION

Do not attach the meter or attempt to move the switch cams until the actuator is disconnected from the line voltage and auxiliary switches are disconnected from external power sources.

Setting Over-travel Protection Switches S3 (Retract) and S4 (Extend)

This procedure should be used if the factory over-travel switch settings must be changed in the field. It is advisable to operate the actuator fully in each direction—using the Handswitch and Handwheel—to check switch settings before attempting to change them. Use the following instructions if they require adjustment:

1. Remove the control end cover and terminal block/DCM-3 cover (1/2" bolt heads).
2. Retract the output shaft to the end of travel limit.
3. Turn the Handswitch to the STOP position.
4. Use the Handwheel to position the output shaft at the desired over-travel limit.
5. Disconnect power from the actuator.
6. Connect the continuity meter across the appropriate terminals. Refer to your actuator wiring diagram (if not available, see the wiring diagram on page 10).
7. Rotate the appropriate cam using a 3/32" hex wrench (or similarly sized tool) in one of the cam adjustment slots (see drawing on opposite page for location of slots) until the meter shows continuity (switch contacts closed, switch clicks).

8. Use the Handwheel and confirm that the contacts are open in the normal operating range and closed at the desired over-travel limit.
9. Disconnect the meter and reconnect actuator power.
10. Repeat instructions for setting (and verifying) the Extend over-travel protection switch (noting that referenced directions of travel should be opposite of those used for the Retract switch setting).
11. Replace covers and tighten cover bolts to 10 lb-ft [14 N•m] torque.

Setting Auxiliary Switches

Standard switch settings for the 2 auxiliary switches are shown on the diagram on the preceding page. The operating point of auxiliary switches is defined as a percentage of output shaft travel. 100% is defined as the Extend limit of shaft travel. The heavy line indicates a closed circuit. Use the following instructions to change the operating point of auxiliary switches:

NOTE: In the following procedure, it is assumed that switch settings are to be adjusted so that contacts are open when the desired position is achieved.

1. Remove the control end cover and the terminal block cover (1/2" bolt heads).
2. Move the output shaft to the desired position.
3. Turn the Handswitch to the STOP position.
4. Disconnect power from the actuator and switch terminals.
5. Connect the continuity meter across the appropriate terminals. Refer to your actuator wiring diagram (if not available, see diagram on opposite page).
6. Rotate the appropriate cam using a 3/32" hex wrench (or similarly sized tool) in one of the cam adjustment slots (see drawing on this page for location of slots) until the meter shows continuity (switch contacts closed, switch clicks).
7. Disconnect the meter and reconnect power.
8. Move the actuator's output shaft in the desired direction so that the cam lobe moves away from the switch lever. If not correct, return to step 2 and reset the cam to the proper orientation.
9. Replace covers and tighten cover bolts to 10 lb-ft [14 N•m] torque.

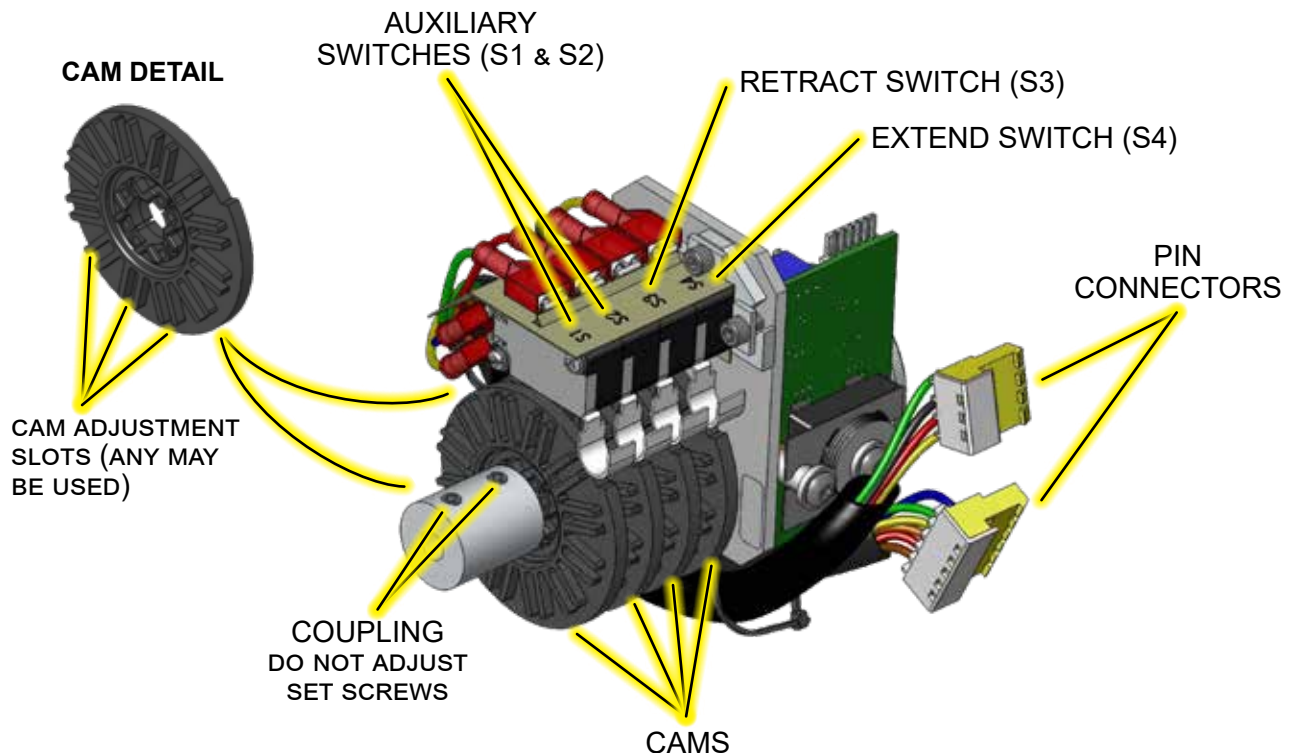

CONTROL END / CONTACTLESS POSITION SENSOR

CONFIGURATION/CALIBRATION

DIRECTION OF OUTPUT SHAFT TRAVEL (EXTEND VS. RETRACT)

Travel direction of the actuator is determined when looking at the output shaft. Direction of travel is defined as the direction of output shaft movement produced by an increasing demand signal. Unless otherwise specified at the time of order, the output shaft is factory-set to extend in response to an increasing signal.

Changing the direction of output shaft travel is easily accomplished using any of the following methods.

Pushbutton method

1. Remove the DCM-3 cover (1/2" bolt heads).
2. Position the actuator at the current 0% position.
3. Press and hold the "CALIBRATE" pushbutton on the DCM-3 local interface panel, then press the "SET POS 100%" pushbutton until the "ACKNOWLEDGE" LED is lit.*

—OR—

2. Position the actuator at the current 100% position.
3. Press and hold the "CALIBRATE" pushbutton on the DCM-3 local interface panel, then press the "SET POS 0%" pushbutton until the "ACKNOWLEDGE" LED is lit.*
4. Ensure the actuator operates as desired.
5. Replace the DCM-3 cover and tighten the cover bolts to 10 lb-ft (14 N•m) torque.

* If the "ACKNOWLEDGE" LED does not light, but the "POSITION" LED does light, the change was not accepted by the DCM-3.

NOTE: When either of the above procedures is performed, both the 0% and 100% positions are automatically set.

HART method

Command: Actuator Dir

DD Menu Location: MENU 4B

Functions>Configuration>General Setup

Selections:

RET Incr - select if the desired output shaft rotation is retract on increasing Demand signal.

EXT Incr - select if the desired output shaft rotation is extend on increasing Demand signal.

Serial command method

Command: drvdir *n*

Arguments: *n*

0: Retract - select if the desired output shaft movement is to retract on an increasing Demand signal.

1: Extend - select if the desired output shaft movement is to extend on an increasing Demand signal.

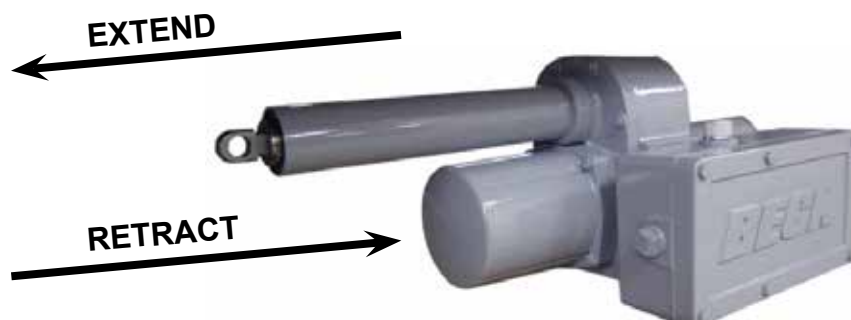

STEP SIZE

Step size represents the minimum amount that the Demand signal must change to initiate a change in actuator position.

When the actuator is in AUTO mode, the DCM-3 runs the motor until the output shaft position matches the percentage of Demand signal. When they match, power is removed from the motor. The Demand signal must change by the step size before power is returned to the motor.

The step size is factory set to 0.15% of full travel span, unless otherwise specified at the time of order. The step size is adjustable from 0.1% to 2.5% of the travel span. Adjustment is typically not required.

It may be advantageous in certain applications, where noise or other problems exist, to increase the step size slightly to prevent excessive modulation.

The step size can be changed using the following methods.

NOTE: Changing this parameter online could cause the actuator to reposition.

HART method

Command: StepSize

DD Menu Location: MENU 4B

Functions>Configuration>General Setup>

Enter the desired step size between "0.10%" and "2.50%".

Serial command method

Command: stepsize #.##%

Arguments: #.##% Desired step size of one incremental movement of output shaft travel (as a percentage of full travel). Acceptable range is between "0.10" and "2.50". If the "%" is not included in the argument, the unit of measurement will default to inches.

RESTORE FACTORY SETTINGS

All DCM-3's are shipped from the factory configured per the customer instructions at the time of order. A complete copy of the factory configuration is stored on the DCM-3. You can revert to the factory settings at any time using one of the following methods.

NOTE: When the factory settings are restored, the Operation Mode (HART DD menu location 3E or Serial command "opmode") will not be changed for safety reasons. The operation mode should be set to "Follow" for normal automatic operation.

HART method

Command: Restore to Factory

Running this function will restore all configurable parameters to the original factory settings.

DD Menu Location: MENU 3C

Functions> Configuration

Serial command method

Command: restoremodes *n*

Arguments: *n*

1: Used as a safety measure, the number one must be entered as an argument to prevent someone from running the restoremodes command errantly.

CONFIGURATION/CALIBRATION

POSITION CALIBRATION

In order to correctly position the actuator output shaft in response to the Demand input signal, the DCM-3 receives a position signal from the actuator's position sensor and compares this actual position to the Demand input. This process requires that the DCM-3 interprets the position signal appropriately for the full range of desired travel. This procedure will calibrate the DCM-3 to accept the position signal and interpret the appropriate 0–100% range. Note that all actuators come factory calibrated and there is no need to recalibrate unless changes in operation are desired.

NOTE: Prior to adjusting the travel range electronically (using the DCM-3), it is recommended that the over-travel protection switches be reset just outside the intended travel range (see page 18).

Calibrate the 0% and 100% positions:

Pushbutton method

1. Move the output shaft to the desired 0% position.
2. Press and hold the “CALIBRATE” pushbutton then press the “SET POS 0%” pushbutton until the “ACKNOWLEDGE” LED is lit.
3. Move the output shaft to the desired 100% position.
4. Press and hold the “CALIBRATE” pushbutton then press the “SET POS 100%” pushbutton until the “ACKNOWLEDGE” LED is lit.
5. Adjust over-travel limit switches as necessary to accommodate the new positions.

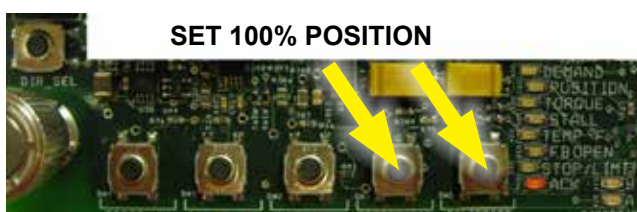
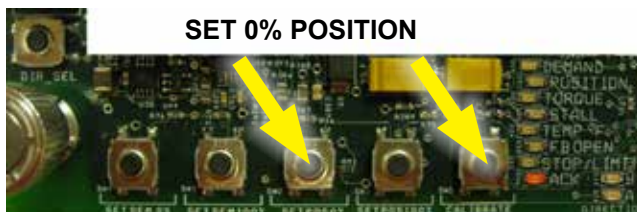

HART method

Command: Set Pos 0%

Select when the output shaft is at the desired 0% position.

Command: Set Pos 100%

Select when the output shaft is at the desired 100% position.

DD Menu Location: MENU 4C

Functions>Configuration>PositionSensrSetup>

Change Travel Inches:

HART method

Command: Travel

Enter the desired full stroke travel in inches.

HART DD Menu Location: MENU 4B

Functions>Configuration>General Setup>

Serial command method

Command: travel ###

Arguments: ### The desired full-stroke travel in inches.

DEMAND CALIBRATION

DCM-3 boards are designed to accept a 4–20 mA (or 1–5 V dc) analog Demand signal. The input comes calibrated from the factory for the full range unless otherwise specified by the customer. It is not necessary to calibrate the Demand input when the actuator is installed; however, if the Demand needs to be calibrated to accommodate unusual operating conditions, two guidelines must be followed: First, the value for 0% must be greater than 0.5 mA and the value for 100% must be less than 21 mA. Second, the difference between 0% and 100% (minimum span) must be at least 4 mA. Use any of the following methods to calibrate Demand. Actuators may also be configured for split-range operation—contact the factory for details.

Calibrate the 0% and 100% Demand signal:

Pushbutton method

1. Ensure the Handswitch is in the “STOP” position. This will prevent the actuator from repositioning during this procedure.
2. Apply the desired 0% Demand input signal to the actuator (e.g., 4 mA for 4–20 mA signal).
3. Press and hold the “CALIBRATE” pushbutton, then press the “SET DEM 0%” pushbutton until the “ACKNOWLEDGE” LED is lit.*
4. Apply the desired 100% Demand input signal to the actuator (e.g., 20 mA for 4–20 mA signal).
5. Press and hold the “CALIBRATE” pushbutton, then press the “SET DEM 100%” pushbutton until the “ACKNOWLEDGE” LED is lit.*
6. Turn the Handswitch to the “AUTO” position. NOTE: The actuator may reposition.
7. Run the actuator through its full operational range to ensure proper response to the Demand input signal.
8. Replace the compartment covers and tighten the cover bolts to 10 lb-ft (14 N•m) torque.

*If the “ACKNOWLEDGE” LED does not light, but the “Demand” LED does light, the calibration is out of acceptable range and was not accepted by the DCM-3. This is typically caused by trying to set 0% and 100% values too close together (i.e., less than 4 mA difference).



HART method

Command: DemRngLwr

Enter the desired 0% Demand signal ("4.00" to "16.00" mA).

Command: DemRngUpR

Enter the desired 100% Demand signal ("8.00" to "20.00" mA).

DD Menu Location: MENU 4D

Functions>Configuration>Demand Setup>

Serial command method

Command: dem0pctma #.##

Arguments: #.## Desired 0% Demand signal ("4.00" to "16.00" mA).

Command: dem100pctma #.##

Arguments: #.## Desired 100% Demand signal ("8.00" to "20.00" mA).

CONFIGURATION/CALIBRATION

LOSS OF DEMAND SIGNAL (LOS)

The DCM-3 is capable of determining if the Demand input signal to the actuator is outside of an acceptable range. The DCM-3 uses a configurable loss of signal (LOS) threshold to determine if the Demand signal falls below a minimum value. Unless otherwise specified in the original order, the factory set threshold is 3.2 mA. When the DCM-3 senses an LOS condition, an alarm condition will result, illuminating the "Demand" status indication LED. The actuator then responds according to the LOS setting. The DCM-3 can be configured for one of two LOS actions:

1. **Stay in Place**—the actuator output shaft stays in place until the Demand signal returns to the acceptable range. This is the factory default.
2. **Go-to-Position**—the actuator output shaft will move to a preset position, designated in percentage of travel. For example, if the LOS action is set for 50%, the actuator output shaft will drive to the 12 mA position (based on a 4-20 mA span).

The LOS parameters can be configured using HART or Serial commands.



CAUTION

The following procedures could cause the actuator to reposition, which can adversely affect the process and cause potentially dangerous conditions.

Configure the LOS threshold:

HART method

Command: DemLimLwr
Enter "0.00" to "12.00" mA. Decimal value of the lower threshold for detecting LOS. (e.g., the typical value for a 4–20 mA system is "3.20").

DD Menu Location: MENU 4D
Functions>Configuration>Demand Setup>

Serial command method

Command: demlos ###

Arguments: ### Enter the desired Demand signal in mA below which LOS occurs (e.g., the typical value for a 4–20 mA system is "3.20").

Configure the LOS mode:

HART method

Command: LOS Mode

DD Menu Location: MENU 4D
Functions>Configuration>Demand Setup>

Selections:

Stay - select if the actuator should hold output shaft position when a loss of signal occurs.

Go-to-Pos - select if the output shaft should go to a specific position when a loss of signal condition occurs. Configure the position with LOS Pos.

Serial command method

Command: demlos *n*

Arguments: *n* Enter the desired mode

sip: (actuator will stay in place).

gtp: (actuator will go to position set in "demlogtp" command)

pat: (same as "sip", but suppresses the alarm).

Configure the LOS position when Go-to-Pos is selected:

HART method

Command: LOS Pos
Enter "-5.00%" to "105.00%". The percentage of full travel the actuator will move upon LOS.

DD Menu Location: MENU 4D
Functions>Configuration>Demand Setup>

Serial command method

Command: demlogtp ###.###

Arguments: ###.### Desired position of actuator if "gtp" is selected in "demlos". Position is expressed as a percentage of actuator travel in decimal form (e.g., 50% = "50.00").

Command: demlogtp delay *n*

Arguments: *n* Time delay in seconds before the actuator will move to the position set in "demlogtp" (0 to 25.5 seconds). Default is "0".

Entering this command without an argument will return the present GTP and delay settings.

Split Range Operation

It is sometimes desirable or necessary to have more than one final control element controlling a single process. Often, this type of control strategy requires that two to four Beck actuators each respond to different portions of one 4–20 mA Demand signal from the control system.

This type of operation is called split range operation. For example, consider the most common split range scenario—two actuators split ranged for 50% of the 4–20 mA Demand signal input. Both actuators are wired in parallel to receive the same 4–20 mA signal (note that the 250 Ohm R11 resistor (see DCM-3 illustration on page 15) must be removed from one of the two actuator DCM-3 boards to allow HART® communications. If more than two actuators are split ranged, the R11 resistor must be removed from all the DCM-3 boards but one), but each actuator's interpretation of the signal must be different. One actuator must interpret 4–12 mA as 0–100% Demand, and one actuator must interpret 12–20 mA as 0–100% Demand. This requires that the actuators have different Demand signal calibrations.

To set up a split range operation, follow the steps listed below.

NOTE: Ensure that the L.O.S. (Loss of Demand input signal) settings of the actuators are appropriate for the configuration. See previous page for information on changing L.O.S. settings.

Pushbutton method

1. Apply the desired 0% Demand input signal to the actuator. (Following the example above, the minimum signal for the first actuator would be 4 mA. The second actuator's minimum signal would be 12 mA).
2. Press and hold the “CALIBRATE” pushbutton then press the “SET DEM 0%” pushbutton until the “ACKNOWLEDGE” LED is lit.
3. Apply the desired 100% Demand input signal to the actuator. (Following the example above, the maximum signal for the first actuator would be 12 mA. The second actuator's maximum signal would be 20 mA)
4. Press and hold the “CALIBRATE” pushbutton then press the “SET DEM 100%” pushbutton until the “ACKNOWLEDGE” LED is lit.

5. Repeat this process for all actuators that need to be split ranged, calculating the proper 0% and 100% Demand limits for each actuator as necessary.

HART method

Command: DemRngLwr

Enter the desired 0% Demand signal (in the example above, "4.00" or "12.00" mA).

Command: DemRngUpr

Enter the desired 100% Demand signal (in the example above, "12.00" or "16.00" mA).

DD Menu Location: MENU 4D

Functions>Configuration>Demand Setup>

Serial command method

Command: dem0pctma #.##

Arguments: #.## Desired 0% Demand signal (in the example above, "4.00" or "12.00" mA).

Command: dem100pctma #.##

Arguments: #.## Desired 100% Demand signal (in the example above, "12.00" or "16.00" mA).

CONFIGURATION/CALIBRATION

DEMAND CHARACTERIZATION CURVES

The DCM-3 can be configured to interpret the applied Demand signal for linear or non-linear output shaft position response. Three predefined Demand signal response curves are available for use including: Linear, Square, and Square Root. A chart of each of these predefined responses is provided for your reference.

In addition to the three predefined characterizer curves, the DCM-3 also allows a custom user-defined curve to be configured. This option is called "Dem Curve Spcl".

The Demand characterization curve type can be configured using the following methods.

Change the Demand characterization curve:

HART method

Command: Dem Curve

DD Menu Location: MENU 4D

Functions>Configuration>Demand Setup

Selections:

Linear - select if the actual position % should match the applied Demand %.

Square Root - select if the actual position % should match the square root of the applied Demand %.*

Dem Curve Spcl - select if a user-defined response is desired (see characterization on the following page to define the desired response curve).

Square - select if the actual position % should match the square of the applied Demand %.

Serial command method

Command: demfunc *n*

Arguments: *n* Enter the integer that represents the desired Demand signal response as follows:

0: Linear - select if the actual position % should match the applied Demand %.

1: Square Root - select if the actual position % should match the square root of the applied Demand %.

4: Special Curve - select if a user-defined response is desired (see characterization on the following page to set the desired response curve).

5: Square - select if the actual position % should match the square of the applied Demand % (e.g., "demfunc 0" sets the actuator to a linear Demand response).

DEMAND SIGNAL RESPONSE CURVES

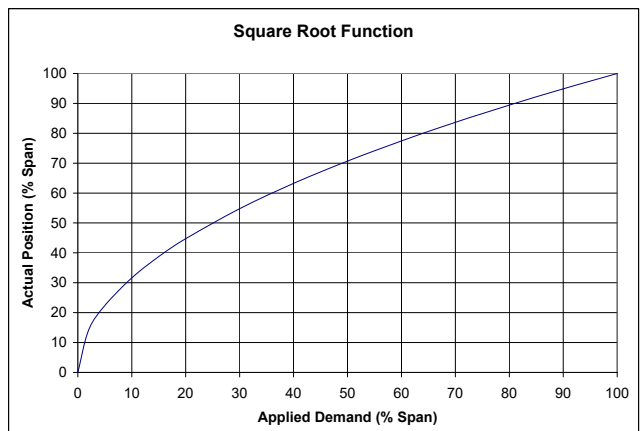
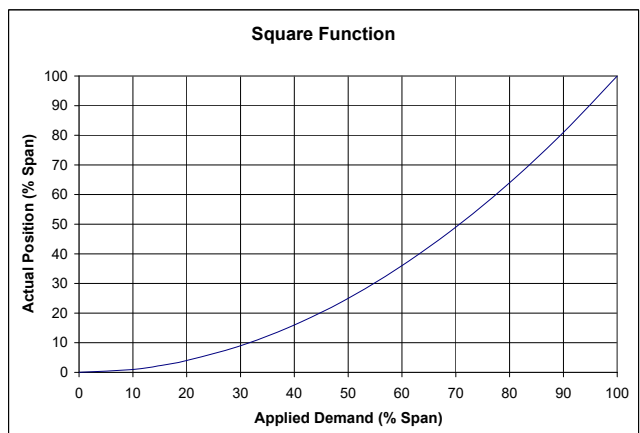
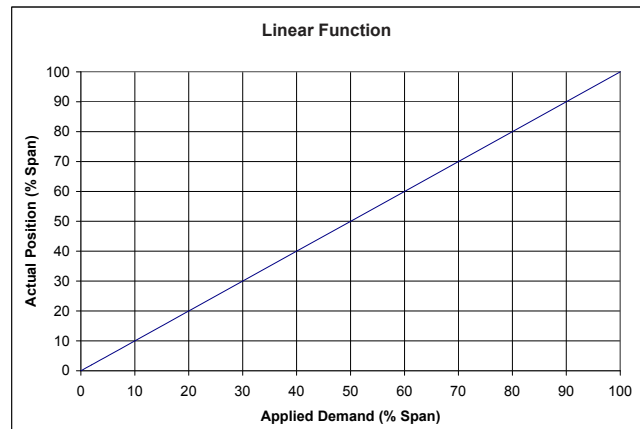

***NOTE**

Implementing a square root characterization creates extremely high gain when the Demand signal is below 10%; this causes instability and is unsuitable for control at this level. Do not apply this curve if the control loop may need to modulate at the lower range of travel.

USER-DEFINED CHARACTERIZATION

Special curves may be created from up to 20 segments, each of which has a node for a starting point and a node for an ending point. All 20 segments do not have to be used, but the used segments must be grouped together starting with segment 1. Segments cannot be skipped.

A node is a coordinate comprised of an X,Y point. When defining nodes, X-values and Y-values must increase as the node number increases. For example, the X-value and Y-value of node 2 must be higher than the X-value and Y-value of node 1. Nodes cannot be skipped. Always start at node 1.

Unless otherwise specified, the Special curve ships from the factory defined as a linear function (i.e., one segment beginning with node 1 at X = 0%, Y = 0% and ending with node 2 at X = 100%, Y = 100%). X-values are typically chosen to give a reasonable spacing in Y-values.

The customer may specify a custom characterization by entering X- and Y-value pairs to define line segments between 0% and 100%.

For example, the table at right uses 5 segments to approximate the square function curve (i.e., $y=x^2$). Segments 1 through 5 are needed, so nodes 1 through 6 are used.

The following methods can be used to configure a user-defined characterization curve.

Change the user-defined characterization:

HART method

Command: DemNode1X

Enter desired X-value as a percentage for node 1

Command: DemNode1Y

Enter desired Y-value as a percentage for node 1

Repeat above procedures for each node required.

DD Menu Location: MENU 5A

Functions>Configuration>Demand Setup>Dem Curve Spcl

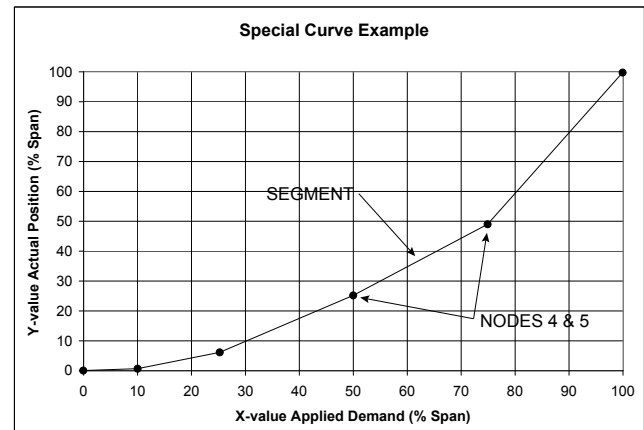

NODE	X-VALUE (DEMAND) % SPAN	Y-VALUE (POSITION) % SPAN
1	0%	0%
2	10%	1%
3	25%	6%
4	50%	25%
5	75%	49%
6	100%	100%

Serial command method

Change the user-defined characterization:

Command: charset *n1*, *n2*, *n3*

Arguments: *n1*, *n2*, *n3*

Where:

n1 = node number.

n2 = X-value as a percentage.

n3 = Y-value as a percentage.

Values must be separated by commas as shown.

Repeat procedure for each node required.

View the user-defined characterization:

Command: charlist ###

Arguments: ### Enter node number between 1 and 21 or "all".

Displays defined nodes.

Clear the user-defined characterization:

Command: charclear ###

Arguments: ### Enter node number between 1 and 21.

Clears a defined node by setting it to unused.

Will also clear any node numerically higher.

CONFIGURATION/CALIBRATION

POSITION FEEDBACK SIGNAL

DCM-3 control electronics provide a 4–20 mA analog output signal that represents the actuator output shaft position. The DCM-3 monitors an internal position voltage from the CPS-4, controls the actuator position, and sources a 4–20 mA signal to terminals DD (–) and EE (+). The Feedback will correspond with the 0% and 100% output shaft positions, as determined by the position calibration. **There is no need for separate Feedback calibration.**

The user has the option of enabling or disabling the position Feedback signal. The factory default configuration will have the Feedback enabled. When the Feedback is enabled, but not in use (i.e., not wired to a load) the "STAT" and "FB OPEN" LEDs will illuminate. This status alarm is helpful in alerting the user to open Feedback wiring, but can be a nuisance when the Feedback is purposely disconnected or unused. Disabling the Feedback signal turns off the output and eliminates the status alarm. If HART or Serial communications are not immediately available to disable the Feedback signal, you can apply a 250 ohm load resistor across the Feedback terminals DD (–) and EE (+) to simulate a Feedback loop and eliminate the alarm.

Use the HART or Serial Commands (detailed on the next page) to set the Feedback signals and corresponding output shaft positions as detailed below.

If desired, the milliamp position Feedback values for 0% and 100% positions can be configured differently than the respective standard factory calibration of 4 mA and 20 mA. A valid 0% position Feedback signal value can be configured anywhere in a 3–16 mA range, while a 100% signal value can be configured from 7–21 mA. The 100% milliamp value must exceed the 0% value by at least 4 mA.

Also, reversed (decreasing direction) Feedback may be selected so that the position resulting from a 4 mA Feedback signal corresponds to the position typically resulting from a 20 mA signal; e.g., 4 mA = 100% position and 20 mA = 0% position. Setting the 0% position to 20 mA will automatically set the 100% position to 4 mA (and vice-versa), and will activate the reverse (decreasing) Feedback function. After accepted, these settings may then be changed as detailed in the paragraph above, only opposite; i.e., a valid 0% position Feedback value is 7–21 mA, while a 100% position may be set at 3–16 mA. The difference between the values can be no less than 4 mA and no greater than 18 mA.

The factory calibrated relationship between the position Feedback signal and the output shaft position is linear (i.e., 0% to 100% Feedback signal corresponds directly with 0% to 100% shaft position). This relationship is suitable for most applications; however, the Feedback to Demand relationship can be changed to compensate for characterized Demand signals. This relationship is called "Inverse Demand". Configuring this option allows the position Feedback signal to match the uncharacterized Demand signal rather than true output shaft position.

The following example assumes 4–20 mA Demand and position signals. If the Demand is set to a square characterization, then a 12 mA Demand corresponds to 25% position. If the position Feedback curve is set to linear, then Feedback at 25% is 8 mA. For some control systems, having the Demand at 12 mA and the Feedback at 8 mA may cause a deviation alarm. The Feedback curve can be set to "Inverse Demand" so the Demand and Feedback match when the actuator is balanced. In this example, with Feedback set to "Inverse Demand" and the output shaft position at 25%, the Feedback signal would be 12 mA.

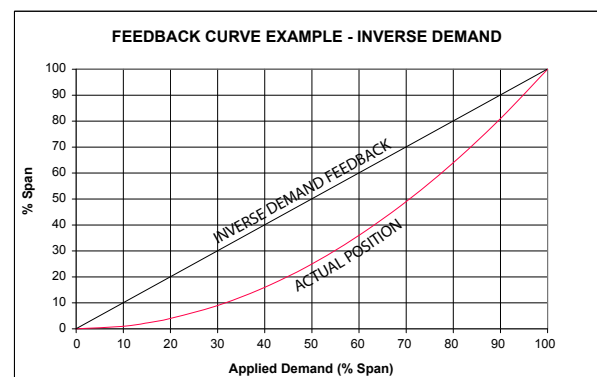
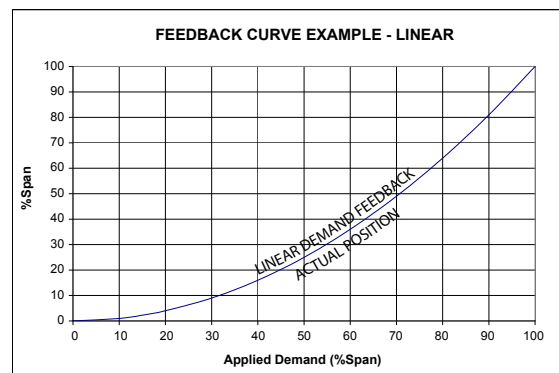

The following methods describe how to enable or disable position Feedback, set the 0% and 100% milliamp values and select the desired Feedback response.

Enable/disable the position feedback:

HART method

Command: Feedback

DD Menu Location: MENU 4E

Functions>Configuration>Feedback Setup>

Selections:

Enabled - to enable position Feedback.

Disabled - to disable position Feedback.

Serial command method

Command: iomode *n*

Arguments: *n*

0: Feedback disabled.

1: Feedback enabled.

Set the feedback range lower and upper values:

HART method

Command: FB RngLwr

Enter the milliamp value that corresponds with 0% position. Acceptable range "3.00"–"16.00" (typically, "4.00").

Command: FB RngUpr

Enter the milliamp value that corresponds with 100% position. Acceptable range "7.00"–"21.00" (typically, "20.00").

DD Menu Location: MENU 4E

Functions>Configuration>Feedback Setup>

Serial command method

Command: fdbk0pctma #.##

Arguments: #.## Desired Feedback signal in mA at 0% output shaft position. The value limit may be no less than "3.00" or, if reversed (decreasing direction), no greater than "21.00".

Command: fdbk100pctma #.##

Arguments: #.## Desired Feedback signal in mA at 100% output shaft position. The value limit may be no greater than "21.00" or, if reversed (decreasing direction), no less than "3.00".

Set the feedback characterization curve:

HART method

Command: FB Curve

DD Menu Location: MENU 4E

Functions>Configuration>Feedback Setup>

Selections:

Linear - to enable a linear feedback signal

InvDem - to enable an inverted Demand feedback signal.

Serial command method

Command: fdbkfunc *n*

Arguments: *n*

0: Linear Feedback signal.

1: Inverse Demand Feedback signal.

CONFIGURATION/CALIBRATION

TEMPERATURE SENSING

DCM-3s are equipped with an internal temperature sensing circuit. The real-time temperature and the historical temperature extremes (low and high) are available.

Temperature units can be selected to show either Fahrenheit or Celsius.

An alarm condition initiates if the actuator's real-time temperature falls outside the actuator rating—the STAT LED and the TEMP F LED will light, and will automatically reset when the temperature is once again within the actuator rating.

View real-time temperature & historical extremes:

HART method

Command: Temp

Displays the real-time temperature as read by the DCM-3.

DD Menu Location: MENU 1

Command: High Temp

Displays the historical high temperature.

Command: Low Temp

Displays the historical low temperature.

DD Menu Location: MENU 3D

Functions>Statistics

Serial command method

Command: temperature

Arguments:

When entered with no argument, the command returns the real-time temperature as well as the historical high and low temperatures.

Set temperature units:

HART method

Command: Temperature Unit

DD Menu Location: MENU 4B

Functions>Configuration>General Setup

Selections:

degF - Set the temp. units to degrees Fahrenheit.

degC - Set the temp. units to degrees Celsius.

Serial command method

Command: temperature *n*

Arguments: *n*

F: Set the temp. units to degrees Fahrenheit.

C: Set the temp. units to degrees Celsius.

STALL PROTECTION

The DCM-3 board provides protection for the actuator in the event of a stall. Stall protection is activated when the actuator is unable to achieve the proper position within a defined stall time due to a mechanical impediment or excessive load.

The DCM-3 senses when the motor moves the output shaft in one direction longer than the configured "stall time". The DCM-3 then shuts off power to the motor, preventing further actuator movement. When the stall condition occurs, the STAT LED will illuminate.

Resetting due to a stall condition is achieved by reversing the Demand signal, cycling the actuator power, or submitting a reset command via HART or Serial port.

The stall protection feature can be enabled or disabled and the stall time may be configured between 30 and 450 seconds. This feature is factory enabled and the default setting is 300 seconds. If reconfiguring, it is advisable to configure the stall time with a value greater than the maximum stroke time to avoid false stall protection events and alarms.

Enable / disable stall protection:

HART method

Command: StallProt

DD Menu Location: MENU 4B

Functions>Configuration>General Setup>

Selections:

Enabled - to enable stall protection.

Disabled - to disable stall protection.

Serial command method

Command: stallprot *n*

Arguments: *n*

0: stall protection enabled.

1: stall protection disabled.

Configure the stall time:

HART method

Command: Stall Time

Enter the stall time in seconds. Valid stall times are 30 to 450 seconds.

DD Menu Location: MENU 4B

Functions>Configuration>General Setup>

Serial command method

Command: stalltime ###

Arguments: ### Enter the stall time in seconds. Valid stall times are "30" to "450".

Reset a stall condition:

HART method

Command: Reset Stall

Select to reset a stall condition.

DD Menu Location: MENU 3E

Functions>Manual Operation>

Serial command method

Command: unstall

Enter to reset a stall condition.

MAINTENANCE

MOTOR ASSEMBLY

The control motor is not field-repairable. **Do not disassemble the motor.** Disassembly of the motor will result in a loss of torque that can only be restored by returning the motor to the factory for re-magnetizing.



WARNING
Electrical shock hazard. Disconnect power before proceeding.

REMOVE THE MOTOR ASSEMBLY:

Remove the actuator from its mounting position.

Remove the terminal / DCM cover ((6) 5/16-18 hex head captive screws).

Remove the capacitor cover ((4) 1/4-20 hex head screws), located beneath the motor.

Remove the (4) 5/16-18 hex head screws retaining the motor, then carefully pull the motor away from the actuator. Motor wire connections may be accessed through the capacitor cover. There are three wires leading from the motor to connections within the actuator (black, red and green). Record where these wires are connected, then disconnect.

INSTALL THE NEW MOTOR ASSEMBLY:

Feed the wires from the new motor into the actuator and connect to the appropriate leads.

Insert the motor into the actuator. Turn the Handwheel as necessary to allow the pinion to slide into and mesh with the gearing. Retain with the (4) 5/16-18 hex head screws and tighten to 10 lb-ft (14 N•m).

Reinstall the capacitor cover with the (4) 1/4-20 hex head cap screws and tighten to 72 lb-in (8 N•m).

Reinstall the terminal / DCM cover. Torque the captive screws to 10 lb-ft (14 N•m).

MOTOR CAPACITOR

There is no recommended replacement interval for the capacitor(s). Nonetheless, it may be advisable to replace these parts as a preventative measure when motors are replaced on older actuators; this is why they are recommended spare parts.



WARNING
Electrical shock hazard. Disconnect power before proceeding.

REMOVE THE CAPACITOR(S):

Remove the capacitor compartment cover (located beneath the motor), (4) 1/4-20 hex head screws.

Ensure there is no voltage across the capacitor(s) and record the exact wire connections to the appropriate capacitor terminals. Remove the wires from the capacitor(s).

There is one capacitor in actuators configured for 60 Hz held in place by two brackets. Remove each bracket ((1) #10-32 slotted head screw each), then remove the capacitor.

There are two capacitors in actuators configured for 50 Hz held in place by a bracket. Remove the (2) #10-32 nuts and washers from the threaded studs to remove the bracket, then remove the capacitors.

INSTALL THE NEW CAPACITOR(S):

Slide the new capacitor(s) into place and secure with the bracket(s). Tighten the bracket screws (or nuts) to 10 lb-in (1 N•m).

Reinstall the capacitor compartment cover with the appropriate screws torqued to 72 lb-in (8 N•m).

MOTOR RESISTOR ASSEMBLY

There is no recommended replacement interval for the resistor assembly. Nonetheless, it may be advisable to replace as a preventative measure when motors are replaced on older actuators; this is why they are recommended spare parts.



WARNING
Electrical shock hazard. Disconnect power before proceeding.

REMOVE THE RESISTOR ASSEMBLY:

Remove the capacitor compartment cover (located beneath the motor), (4) 1/4-20 hex head screws.

Remove the terminal / DCM cover ((6) 5/16-18 hex head captive screws).

Remove the DCM board by disconnecting the wire harness connector from the top of the board and any other wire connections on the board. Loosen the (4) DCM captive thumb fasteners (#10-32) and carefully pull the DCM out of its socket.

Remove the (4) 1/4-20 hex head screws fastening the DCM mounting bracket to the actuator. The mounting bracket will remain attached to a wire harness. Carefully move the bracket aside and hold in place (using string, wire, etc.).

Remove the (4) #8-32 slotted screws holding the terminal board in place. The terminal board will remain attached to wires. Carefully move the board aside similarly to the DCM bracket, as stated above.

The resistor assembly should now be exposed, with three wires leading from the assembly to joints within the capacitor compartment. Note the locations of these wires, then disconnect at the joints. Remove the resistor assembly ((4) #4-40 cross recessed head screws).

INSTALL THE NEW RESISTOR ASSEMBLY:

Install the new resistor assembly in the same orientation as was the old assembly. Torque the appropriate screws to 5 lb-in (.5 N•m).

Refasten the terminal board. Torque the appropriate screws to 19 lb-in (2 N•m).

Refasten the DCM bracket. Torque the appropriate screws to 72 lb-in (8 N•m).

Reinstall the DCM board. Carefully slide the board into the socket on the bracket. Tighten the captive fastener screws to 19 lb-in (2 N•m). Reattach all of the wire connectors removed earlier to the appropriate plugs.

Reinstall the capacitor cover with the (4) 1/4-20 hex head cap screws and tighten to 72 lb-in (8 N•m).

Reinstall the terminal / DCM cover. Torque the captive screws to 10 lb-ft (14 N•m).

SELF-LOCKING MECHANISM (SLM)

In normal service, the SLM friction surface should not require replacement; however, a combination of excessive modulation and load can cause wear to the SLM mechanism. If the SLM has been damaged, a replacement kit is available (see table and figure at right). Kits include all necessary parts and detailed instructions.

SLM REPLACEMENT KIT 12-8064-73

Part Number	Description
30-0319-36	Bearing Clamp Nut
14-9400-15	Thrust Bearing
14-9409-54	Friction Liner (GL 181-134)
14-9980-26	Compression Spring
14-9940-50	Motor Pinion
14-9420-03	Steel Ball (8)
14-9330-50	Locking Disc
20-0660-76	Terminal Enclosure Gasket
20-0661-35	Motor Gasket
20-0661-36	Capacitor Compartment Gasket
20-0661-37	Resistor Cover Gasket

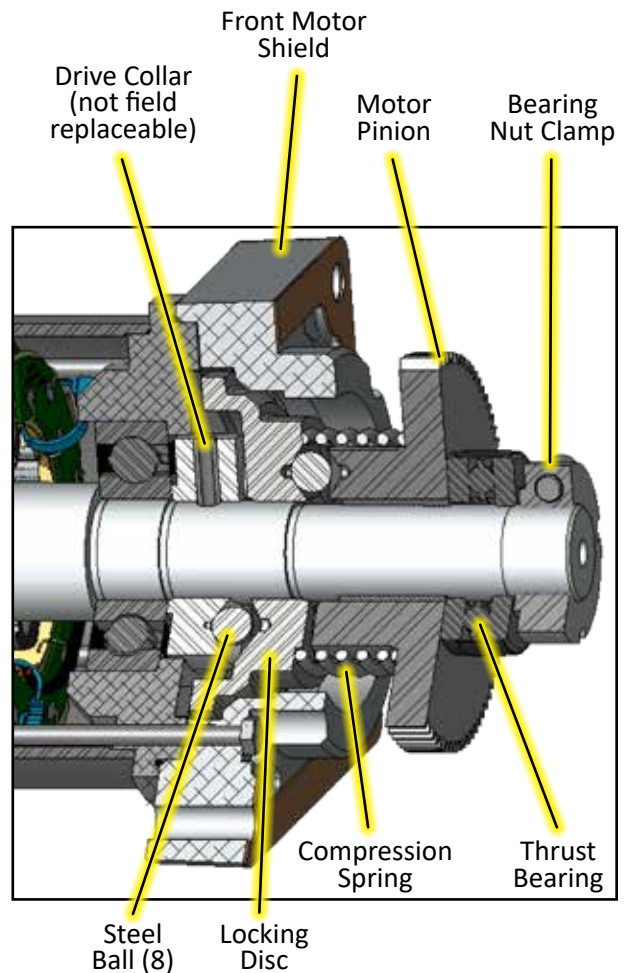

**SLM CUTAWAY
(MOTOR 20-2703-50 SHOWN)**

MAINTENANCE

OVER-TRAVEL LIMIT AND AUXILIARY SWITCHES

Complete switch assemblies may be replaced. It is not possible to replace individual switches.



WARNING

Electrical shock hazard. Disconnect power before proceeding.

REMOVE THE SWITCH ASSEMBLY:

To replace the switch assembly, first remove the control end cover by loosening the (4) 5/16-18 hex head captive screws. Carefully pull the cover straight back when removing to prevent damaging components.

Disconnect the switch assembly by unplugging the two pin connectors leading to the mounting bracket. Use a flat-tipped screwdriver to press the release tab straight back and slide the plug out of the socket.

Carefully clip the cable tie that holds the switch assembly wires together with the wire leading to the P.C. board.

Remove the switch assembly screws (#6-32 socket head cap) and rectangular washers. Carefully lift the switch assembly away from the actuator.

INSTALL THE NEW SWITCH ASSEMBLY:

Carefully position the new assembly and secure in place by tightening the switch assembly screws (with the washers) to the mounting plate (tighten to 10 lb-in (1 N•m)).

Transfer the wiring from the old assembly lugs to the new assembly lugs one at a time.

Reattach the pin connectors and replace the cable tie holding the switch assembly wires together with the wire for the P.C. board.

Ensure the switches actuate properly; if not, adjust the distance between the cams and the switches by loosening the switch assembly screw (and washer) closest to the cams. The switches-to-cams distance may then be adjusted by moving the assembly within the screw slot. Once adjusted properly, re-tighten the screw (and washer) to 10 lb-in (1 N•m).

Reinstall the control end cover by tightening the captive screws to 10 lb-ft (14 N•m).

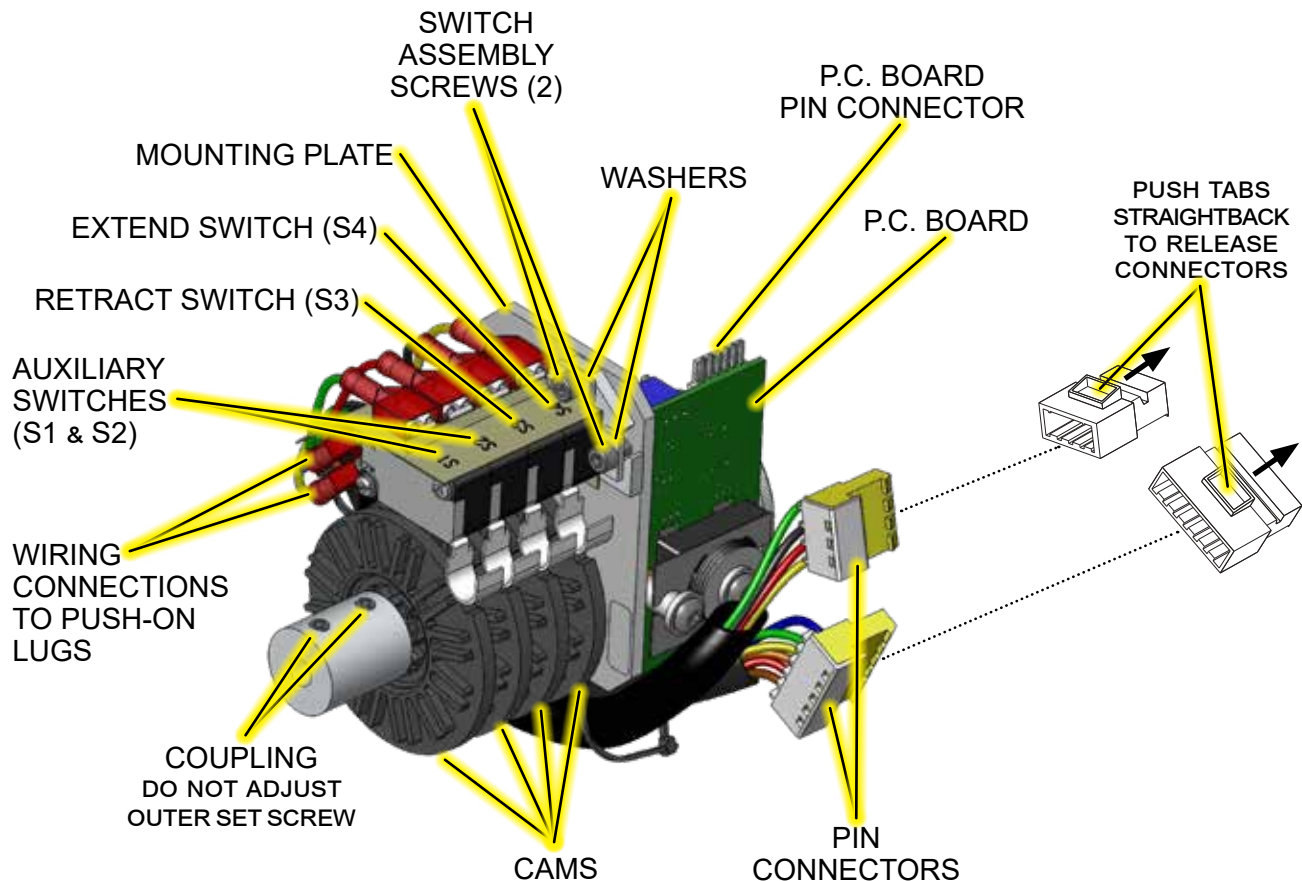

HANDSWITCH

The Handswitch is a non-wear item that only requires replacement if physically damaged.



WARNING
Electrical shock hazard. Disconnect power before proceeding.

REMOVE THE HANDSWITCH ASSEMBLY:

Remove the terminal / DCM cover ((6) 5/16-18 hex head captive screws).

Loosen (do not remove) the (2) #8-32 socket set screws on the Handswitch. Remove the (2) #6-32 Phillips head screws from the Handswitch adaptor (base).

Pull the Handswitch assembly far enough from the enclosure to allow access to its wires. Cut the wires, allowing enough length to splice them to the new Handswitch assembly.

INSTALL THE NEW HANDSWITCH ASSEMBLY:

Splice the wires from the new Handswitch onto the cut wires, color-for-color. Reinstall the Handswitch adaptor, ensuring the pin is oriented toward the extension tube of the actuator. Tighten the (2) #6-32 screws to 10 lb-in (1 N•m).

Join the Handswitch knob to the assembly (through the adaptor) and hand-tighten the #8-32 screws on the knob.

Reinstall the terminal / DCM cover. Torque the captive screws to 10 lb-ft (14 N•m).

DCM-3

Field service of the DCM-3 board is not recommended. The factory maintains a stock of replacement boards for immediate shipment.



WARNING
Electrical shock hazard. Disconnect power before proceeding.

REMOVE THE DCM:

Remove the terminal / DCM cover ((6) 5/16-18 hex head captive screws).

Remove the DCM board by disconnecting the wire harness connector and any wire connections from the board. Loosen the (4) DCM captive thumb fasteners (#10-32) and carefully pull the DCM out of the board connector socket.

INSTALL THE NEW DCM-3:

Install the new DCM-3 board. Carefully slide the board connector into the socket. Tighten the captive fastener screws to 19 lb-in (2 N•m). Reattach any wire connectors previously removed to the appropriate plugs.

Reinstall the terminal / DCM cover. Torque the captive screws to 10 lb-ft (14 N•m).

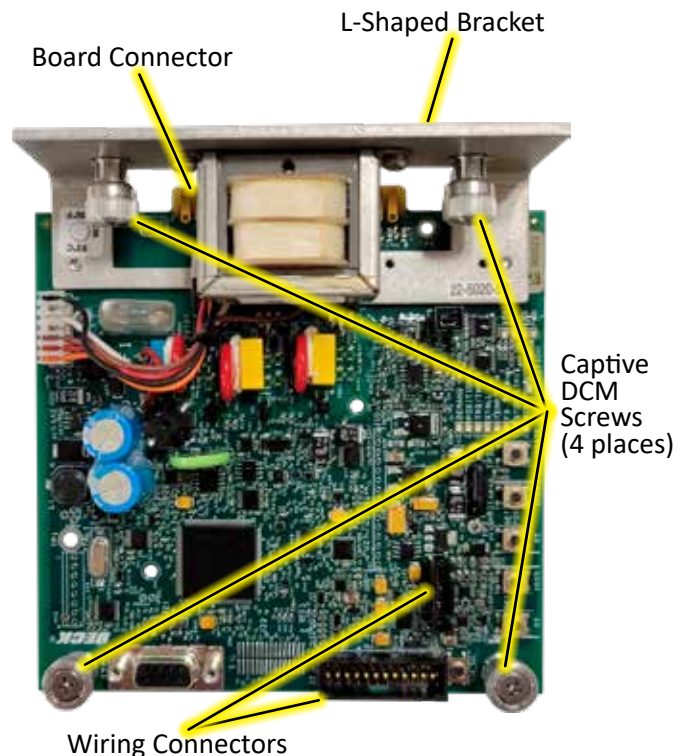

NOTE: Layout may vary slightly depending on DCM version.

DCM-3

MAINTENANCE

CONTROL END ASSEMBLY

Repair of the CPS-4 and control end are not recommended. Kits are available to replace The CPS-4 switch assembly, coupling and P.C. Board. If necessary, the entire control end assembly may be replaced. Replacement control end assemblies are fully calibrated at the factory.



WARNING
Electrical shock hazard. Disconnect power before proceeding.

REMOVE THE CONTROL END ASSEMBLY:

Remove the control end cover by loosening the (4) 5/16-18 hex head captive screws. Carefully pull the cover straight back when removing to prevent damaging components.

See image on page 34 for component identification. Disconnect the switch assembly by unplugging the two connectors leading to the mounting bracket. Use a flat-tipped screwdriver to press the release tab straight back and slide the plug out of the socket. Also, disconnect the pin connector on the P.C. board, which slides off with moderate force.

Carefully clip the cable tie that holds the switch assembly wires together with the wire leading to the P.C. board.

Loosen the innermost setscrew on the coupling. Do not loosen the outer setscrew.

Use a fine point marker to note the position of the control end relative to the actuator body. Mark the face of the actuator immediately adjacent to the top of the notch (see below).

Loosen (do not remove) the mounting clamp screws, (4) #8-32 socket button head screws (2 per clamp), and slide the top clamp up over the edge of the shoulder in the body, immediately above the stator flange (see below). Snug one of the screws to hold the clamp up while replacing the assembly. Allow the bottom clamp to hang by the screws.

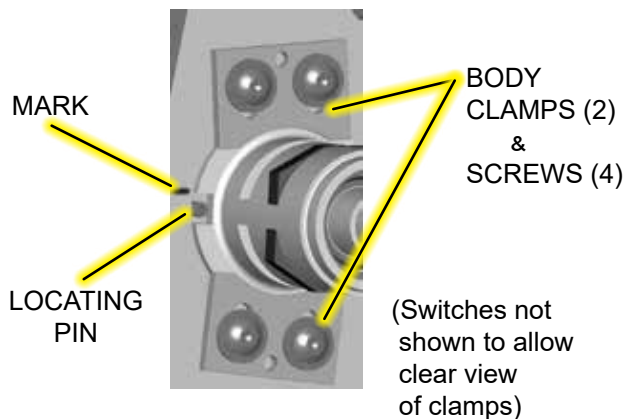

Slide the control end assembly away from the actuator body until it clears the control end shaft.

INSTALL THE NEW CONTROL END ASSEMBLY:

Slide the new assembly onto the shaft, turning the coupling (if necessary) to align the assembly with the shaft. Align the notch in the stator with the locating pin situated to the left of the control end shaft (see image below).

Loosen the clamp screw to allow the top clamp to drop into place over the upper rim of the stator. Rotate the assembly as necessary to align the top of the notch with the mark made earlier on the actuator face. Snug the screws down on the plate. Raise the bottom clamp into position and snug its screws down. Check the clamps for proper shoulder clearance and tighten the (4) #8-32 socket button head screws to 12 lb-in (1 N•m) torque.

Plug the pin connectors into their respective sockets.

Tighten the inner setscrew on the coupling. To properly align the assembly, make sure that the setscrew is properly lined up with the flat on the shaft. Torque screw to 12 lb-in (1 N•m).

GASKETS

During routine service, inspect removed cover gaskets for wear or damage. In order to protect internal components, worn or damaged gaskets and O-rings should be replaced.

To remove, scrape all of the old adhesive and gasket material from the body housing and cover. Some covers (CPS/control end and DCM/terminal block) have self-adhering, silicone rubber gaskets. Peel the backing off the replacement gasket and carefully apply to the actuator body. Other covers (motor, motor capacitor, transformer) have gaskets that are a cork-rubber composite. Cement the new gasket to the actuator body using a gasket cement such as 3M #847 Rubber and Gasket Adhesive, or equivalent.

FUSE (F1) REPLACEMENT (FOR ACTUATORS EQUIPPED WITH 3-PHASE POWER)

If it is necessary to replace the power fuse (F1), use the following procedure:



WARNING
Electrical shock hazard. Disconnect power before proceeding.

Remove the terminal block cover. Locate the fuse holder (similar to the illustration below).

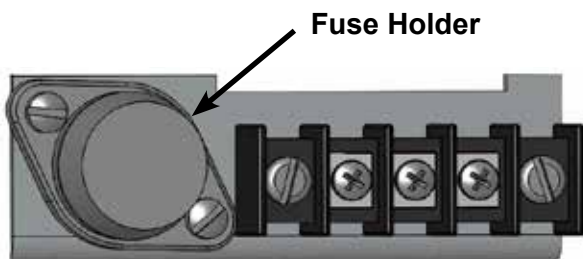

Turn the fuse holder CCW while pressing down. The fuse holder should spring loose when free. Remove the fuse holder from the actuator. Pull the fuse free from the holder. Replace the fuse with the same type (see table below) by pushing it into place.

Reinsert the fuse holder into the actuator. Turn the fuse holder CW while pressing down to tighten. Replace the terminal block cover. Tighten the cover screws to 6 lb-ft (8 N•m) torque.

REPLACEMENT FUSES (F1)

Input Voltage	Amps	Volts	Type	Part No.
208	0.3	250	Time Delay	11-1370-15
240	0.3	250	Time Delay	11-1370-15
380	0.2	600	Time Delay	11-1372-16
415	0.2	600	Time Delay	11-1372-16
480	0.2	600	Time Delay	11-1372-16
575	0.125	600	Time Delay	11-1372-11

HOW TO ORDER SPARE PARTS

Select the needed parts from the list below. Specify the actuator's model / serial number (example: 42-109-031891-01-02) given on the nameplate to allow the factory to verify the part selection. Parts may be ordered by mail, telephone or fax, with the confirming order sent to the factory (see back cover).

SPARE PARTS / REPLACEMENT PARTS

CUSTOMER KIT	PART NUMBER
Capacitor Replacement, 6.0Nm 72 RPM Motor, 60Hz	12-8064-10
Capacitor Replacement, 6.0Nm 72 RPM Motor, 50Hz	12-8064-20
Resistor Replacement, 6.0Nm 72 RPM Motor	12-8064-14
Motor (w/ SLM Replacement), 6.0Nm 72 RPM Motor	12-8064-01
SLM Replacement	12-8064-73
Handswitch Replacement	12-8064-09
DCM-3 Replacement	12-8062-31
Control End Replacement, CPS-4	12-8064-55
CPS-4 Switch Assembly	12-8064-56
CPS-4 P.C. Board Replacement	12-8064-07
Transformer (240 Volt)	12-8064-02
DCM-3 Fuse Replacement	12-8062-32
Fuse (F1) w/ 3-phase power options	See above
DPDT Relay (120 Volt)	20-2872-08
DPDT Relay (240 Volt)	20-2872-09
Gasket Replacement	20-3110-18

TROUBLESHOOTING

The DCM-3 features diagnostics to help troubleshoot problems.

The following list provides a systematic method for isolating any actuator problems.

1. Operating Voltage
2. Handswitch Operation
3. DCM-3 Status Indication LEDs
4. DCM-3 Testpoints
5. DCM-3 Configuration
6. Shaft Position
7. Inhibitors / Statistics

VERIFY OPERATING VOLTAGE

To check the input power supply, view the Status Overview LEDs on the DCM-3 board (see illustration, page 15). This requires removing the Terminal/DCM compartment cover (see page 7 for location).

The PWR LED should pulse from dim to bright, which indicates that power is applied to the actuator and the DCM-3 is successfully completing (continuous) self-tests. If the PWR LED is not lit or pulsing, there may be a problem with the AC power supply to the actuator.

Ensure the actuator is receiving the proper operating voltage (listed on the actuator nameplate). To check the voltage, locate the power terminals on the terminal block (see wiring diagram on the underside of the terminal compartment cover). Using a voltmeter, measure the voltage applied to those terminals. If the voltage is correct, continue troubleshooting; if the voltage is not correct, apply the proper power.

CHECK HANDSWITCH OPERATION

Verify proper operation of the Handswitch, which bypasses the actuator control electronics and switches power directly to the motor windings. Operate the actuator in both directions of travel using the Handswitch. If the actuator responds as expected, electro-mechanical problems with the motor and gearing may be eliminated. The trouble may lie with the electronics.

CHECK DCM-3 STATUS INDICATION LEDES

The DCM-3 has seven Status Indication LEDs that provide specific information about the actuator's state (page 16). A lit LED indicates that a condition exists.

CHECK DCM-3 TESTPOINTS

The DCM-3 controls actuator output position by comparing the actuator's Demand input signal with

the internal Position feedback signal generated by the actuator's position sensor (CPS-4). The integrity of these signals is critical to actuator performance. The signals should be verified whenever there are actuator problems. There are four test points provided on the DCM-3 board (see next page for locations) that are used to measure the Demand input and internal Position signals directly at the DCM-3.

Measure the Demand signal voltage across TP2(+) and TP3(-). A typical 4–20 mA input signal will measure a proportional 1–4 V dc across the test points. It is important to verify that the measured voltage corresponds correctly to the signal that is being applied. If there is a mismatch, further troubleshooting is required.

The Position signal to the DCM-3 is generated by the actuator's CPS-4. The CPS-4 is designed to provide a 1–4 V dc signal to the DCM-3 corresponding to 100% of actuator output shaft travel. The Position signal can be determined at the DCM-3 by measuring the voltage across TP4(+) and TP1(-). Verify that this signal matches Demand and the position of the output shaft.

Both the Demand and Position signals can also be checked at the appropriate terminals in the terminal block, via HART communications or through the Serial port. All values should agree with test point values. Any differences will require further troubleshooting.

CHECK DCM-3 OPERATION MODE SETTING

The DCM-3 can be configured for several operational modes as shown in HART menu 3E (page 47) or Serial command "opmode" (page 56).

The factory configuration is the "Follow" mode. In this mode, the actuator is positioned by the 4–20 mA Demand signal when the Handswitch is set to AUTO.

The "Hold" mode causes positioning according to the HART interface Demand value (HART menu 3E).

The "Stay" mode causes the output shaft to maintain its present position. In "Stay" mode, the Handwheel cannot be freely turned as it will move back to the position where the "Stay" mode was activated.

The "Stop" mode removes power from the motor. In "Stop" mode the Handwheel can be freely turned. All operating modes can be overridden by the actuator Handswitch. If the operation mode is (inadvertently) switched to a mode other than "Follow" there will not be an outward indicator.

Note that resetting the DCM-3 to factory settings does not change the operational mode back to "Follow" for safety purposes.

CHECK SHAFT POSITION

The output shaft position (%) can be viewed in HART (menu 1) or by running the Serial command "stat".

If the Position value (%) does not appear to match the physical output shaft position, a position calibration may be required. Follow one of the procedures listed on page 22.

Note: The position signal can be measured across DCM-3 test points TP4 (+) and TP1 (-).

CHECK DCM-3 INHIBITORS / STATISTICS

Conditions that prevent the DCM-3 from positioning the actuator are called inhibitors. HART MENUS 5F and 5G list the RET and EXT inhibitors respectively. Inhibitors may also be reviewed by running the Serial command "stat" (see page 58). The following list indicates why the inhibitor would be in the "ON" state.

Balance

Demand and position are balanced.

Supervisory

DCM-3 is initializing.

Stall

A stall condition has been detected.

OverTrq/Thr

Excessive thrust load on the output shaft.

Switch Block

Handswitch, Override or Limit Switch is inhibiting movement.

Bad Pos Sig

The Position signal is out of range.

Bad Dem Sig

The Demand signal is out of range.

Local Cal

The calibrate button is being pressed on the pushbutton panel.

The factory can assist with troubleshooting—please provide the results of the above review to expedite assistance.

TROUBLESHOOTING

CONDITIONS	POSSIBLE CAUSES	CORRECTIONS
1. No DCM-3 LEDs are illuminated.	<ul style="list-style-type: none"> a. No power is applied to the actuator. b. Incorrect power is applied to the actuator. c. Main power fuse/breaker is blown. d. DCM-3 malfunction. 	<ul style="list-style-type: none"> a. Apply operating voltage to the operating voltage terminals. b. Verify correct voltage on actuator nameplate and ensure that it is applied at the operating voltage terminals. c. Verify fuse/breaker integrity. Replace/reset if blown. Find cause of short circuit. d. Replace DCM-3.
2. STAT LED is illuminated.	<ul style="list-style-type: none"> a. A status alarm is active. 	<ul style="list-style-type: none"> a. Check the status indication LEDs on the pushbutton interface of the DCM-3. Continue troubleshooting based on the LEDs that are illuminated.
3. Demand LED is illuminated.	<ul style="list-style-type: none"> a. No Demand signal. b. Applied Demand signal is outside of configured range. c. Polarity of applied signal wires is reversed. 	<ul style="list-style-type: none"> a. Apply a Demand signal to terminals AA (+) & BB (-). b. Confirm Demand signal value via HART or by measuring DC voltage across DCM-3 test points TP3(+) & TP2(-). Should be 1–4 volts for 4–20 mA applied signal. c. Correct the polarity of the applied control signal wires on terminals AA (+) & BB (-).
4. POSITION LED is illuminated.	<ul style="list-style-type: none"> a. Position signal voltage generated by CPS-4 read by the DCM-3 is outside of the configured range. b. CPS-4 malfunction. c. DCM-3 malfunction. 	<ul style="list-style-type: none"> a. Using the HART communicator check the Position Sensor Setup menu to verify the Present CPS voltage falls within the configured CPS Zero% and Span (typical range ~1–4 volts); OR measure DC voltage between DCM-3 test points TP4 (+) and TP1 (-) to verify Present CPS voltage. If the voltage is outside of ~1–4 volts, recalibrate or replace the CPS-4. b. Replace CPS-4. c. Replace DCM-3.
5. TRQ/THRUST LED is illuminated.	<ul style="list-style-type: none"> a. Thrust exceeding configured limit (typically over 150% of rated thrust) is being applied to the output shaft. b. Thrust Null and Thrust Constant values are not set correctly. c. Thrust cable is not connected to DCM-3. 	<ul style="list-style-type: none"> a. Eliminate cause of excessive thrust (i.e., binding damper, improper linkage, etc.). b. Locate Thrust Null and Constant values inside DCM compartment and set via HART or Serial port. c. Reconnect thrust cable to DCM-3.
6. STALL LED is illuminated.	<ul style="list-style-type: none"> a. Actuator has stalled—unable to achieve desired position within the configured “STALL TIME”. b. The configured stall time is less than the configured Max Travel Time. 	<ul style="list-style-type: none"> a. Eliminate the obstruction and reset the stall by reversing direction on your Demand signal, cycling the power, or issuing the stall reset from HART or Serial command. b. Configure the stall time to exceed the Max Travel Time via HART or Serial command.
7. TEMP F LED is illuminated.	<ul style="list-style-type: none"> a. The measured temperature at the DCM-3 is outside of the normal operating range of -40° to 185° F. 	<ul style="list-style-type: none"> a. Protect the actuator from the extreme temperatures below or above the operating range to eliminate the alarm.
8. FB OPEN LED is illuminated.	<ul style="list-style-type: none"> a. The position Feedback circuit current loop is not complete. b. The position Feedback is enabled, but not in use. 	<ul style="list-style-type: none"> a. Ensure the device measuring the 4–20 mA Feedback is properly terminated on terminals DD (-) and EE (+) and is applying a 0–500 ohm load resistance. b. Disable Feedback via HART or Serial command; OR terminate the Feedback loop by applying a 0–500 ohm load resistance across terminals DD and EE.

CONDITIONS	POSSIBLE CAUSES	CORRECTIONS
9. STOP/LIMIT LED is illuminated.	<ul style="list-style-type: none"> a. The applied power is below the tolerance (-15%) of the nameplate operating voltage. b. A DCM-3 fuse is open. c. A component failure has occurred on the DCM-3. d. The Handswitch is in STOP. e. The actuator has traveled to an over-travel limit switch. f. The actuator is not at an over-travel limit switch, but the limit switch is open. 	<ul style="list-style-type: none"> a. Apply the correct operating voltage to the actuator per the voltage stamped on the nameplate. b. Replace the open fuse. c. Replace the DCM-3. d. Place the Handswitch in AUTO. e. Verify if the limit switch is set outside of the electrically calibrated limits. Readjust, if necessary, or replace. f. Replace the over-travel limit switch assembly.
10. Power LED is pulsing bright to dim.	a. This indicates normal function.	a. No action required.
11. All LEDs are illuminated or flashing.	a. A component failure has occurred on the DCM-3.	a. Replace the DCM-3.
12. REV LED is illuminated, actuator is not moving, and there are no other status alarms.	a. Operation mode is set to "STOP".	a. Using HART (operation mode menu) OR using Serial command "opmode", change operation mode to "Follow".
13. Actuator will not hold position with Handswitch in STOP.	a. Self Locking Mechanism (SLM) is worn or damaged.	a. Rebuild the SLM assembly.
14. Motor runs, but the output shaft does not move in one or both directions.	a. Self Locking Mechanism (SLM) has failed.	a. Rebuild the SLM assembly.
15. PWR LED is flashing, no status LED's are lit and does not respond to Demand signal or Handswitch.	<ul style="list-style-type: none"> a. The Handswitch is damaged. b. The Handswitch jumper between terminal A and C is missing or faulty. 	<ul style="list-style-type: none"> a. Check continuity from terminals N to V and M to U with Handswitch in AUTO position. If either does not show continuity, replace Handswitch. b. Install a wire jumper between terminals A and C.
16. PWR LED is flashing, no status LED's are lit, actuator functions with the Handswitch, but does not respond to Demand signal.	a. A plug-in jumper has been installed in the 24-pin connector (J2) of the DCM-3 board.	a. Remove any jumpers from the J2 connector on the DCM-3.
17. HART communications cannot be established with the DCM-3.	<ul style="list-style-type: none"> a. The device description (DD) file is not installed. b. The HART communicator is not compatible with Beck equipment. c. The HART communications circuit on the DCM-3 is damaged. 	<ul style="list-style-type: none"> a. Install the Beck MK-2 DD on your HART device. b. Utilize a compatible HART communicator or configure the actuator through the Serial port. c. Replace the DCM-3.
18. Position voltage on DCM-3 testpoints TP4 and TP1 is within 1–4 volts DC following the actuator position, but the position Feedback signal at terminals DD and EE remains constant or is erratic.	a. The position Feedback circuit on the DCM-3 is damaged.	a. Replace the DCM-3.

TROUBLESHOOTING

CONDITIONS	POSSIBLE CAUSES	CORRECTIONS
19. Output shaft rotates opposite of desired direction when applying a 4–20 mA Demand signal.	a. The rotation direction is incorrectly configured.	a. Configure the rotation direction using pushbutton, HART, or Serial method.
20. Motor erratic or runs in wrong direction in AUTO or using Handswitch.	a. Motor winding is open. b. Motor capacitor is shorted or open. c. Motor resistor is open.	a. Replace motor assembly. b. Replace capacitor. c. Replace resistor assembly.
21. Actuator does not follow input signal until maximum or minimum is reached, then drives uncontrollably to limit.	a. Wire jumpers on terminals M and N are reversed. b. CPS-4 is not calibrated.	a. Connect terminal jumpers from M to F and from N to D. b. Recalibrate the CPS-4.
22. Actuator oscillates in AUTO mode.	a. Excessive noise on the input signal. b. Physical obstruction causing a stall condition (e.g., valve jammed or load greatly exceeds actuator rating.) c. The DCM-3 is malfunctioning. d. Excessive wear in the gear train or bearings. e. CPS-4 Failure. f. Self Locking Mechanism (SLM) is worn or damaged.	a. Eliminate noise or increase actuator step size. b. Check operation with Handswitch and remove obstruction if present. Handswitch bypasses the DCM-3 board. c. Replace the DCM-3 board. d. Replace worn actuator parts. e. Replace the CPS-4 board. f. Rebuild the SLM.
23. Actuator will not run in either direction or one direction in AUTO or using Handswitch.	a. Over-travel limit switch failure. b. Handswitch failure.	a. Replace over-travel limit switch assembly. b. Replace Handswitch assembly.
24. Actuator does not stop at normal or desired limit of shaft travel.	a. DCM-3 position calibrated incorrectly. b. Limit switches set incorrectly. c. Over-travel limit switch failure.	a. Calibrate DCM-3 0% and 100% positions. b. Readjust the limit switches. c. Replace the over-travel limit switch assembly.
25. Position Feedback signal does not reach maximum signal, but low end calibration is correct.	a. Feedback loop is overloaded.	a. Make sure that the load resistance is between 0 and 500 ohms total across terminals DD and EE.
26. Actuator runs uncontrolled to one end of travel.	a. Handswitch Failure. b. The DCM-3 is malfunctioning. c. The CPS-4 is malfunctioning. d. Terminal block jumpers F to M and D to N not connected. e. The actuator has detected a loss of Demand signal (LOS) and is configured for GTP 0% or 100%. f. Handswitch in RET or EXT position.	a. Check continuity from terminals A–V and A–U with Handswitch in AUTO and actuator power disconnected. If either shows continuity, replace Handswitch. b. Verify CPS-4 voltage signal at DCM-3 test points TP4 and TP1 for 1–4 volts DC corresponding with output shaft position. If signal is valid, replace DCM-3. c. Verify CPS-4 wire connections, check voltage at DCM-3 test points TP4 and TP1 for 1–4 volts DC corresponding with output shaft position. Replace CPS-4 if voltage does not change with position. d. Install jumpers. e. See troubleshooting condition no. 3 ("Demand LED is illuminated"). f. Return Handswitch to AUTO position.

APPENDIX HART® Communication

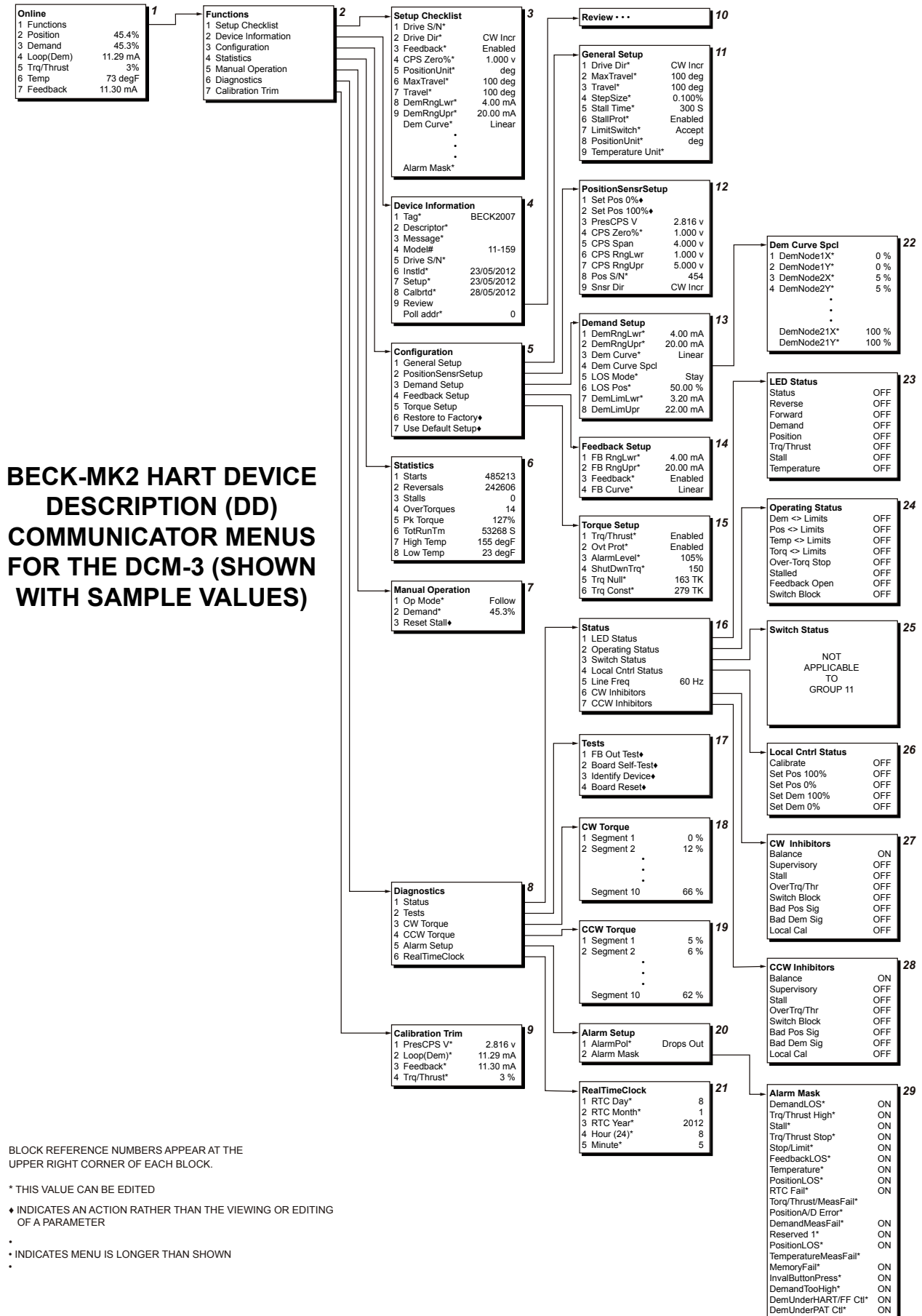

BLOCK REFERENCE NUMBERS APPEAR AT THE UPPER RIGHT CORNER OF EACH BLOCK.

* THIS VALUE CAN BE EDITED

◆ INDICATES AN ACTION RATHER THAN THE VIEWING OR EDITING OF A PARAMETER

• INDICATES MENU IS LONGER THAN SHOWN

APPENDIX HART® Communication

The DCM-3 board is the control center of the actuator—configuration and calibration are accessed and set through the DCM-3 board. Using the HART interface requires a HART compatible communicator or any device, computer or controller capable of communicating with HART devices and supporting the Beck DCM-3 Device Description (DD).

HART® INTERFACE

The interface menu tree for communicating with a DCM-3 using the BECK-MK2 DD is located on the previous page. This menu tree summarizes possible setup options, features and available information.

HART® COMMUNICATORS FOR BECK-MK2

The BECK-MK2 Device Description requires a HART Communicator that is HART 5 capable and has the ability to import Device Description Language Files (DDL) that are certified by the HART Communications Foundation.

USING THE 275, 375 OR 475 HART® COMMUNICATOR

The HART Communicator leads should be connected in parallel with the analog Demand

signal wiring. This allows the communicator to simultaneously communicate over the analog input wires. This does not disturb the analog Demand signal, or disrupt the DCM-3 functions. However, any program changes to the DCM-3 will momentarily suspend the operation of the board (maintains last state) while the change is implemented. Typically, this is only for a second or two.

With the communicator connected in parallel anywhere across the analog Demand wires (see illustration below), it is ready to communicate. Turn on the communicator and wait for communications to be established. When communications are established, the “Online” display will appear. If the actuator is multidropped with other devices on a HART network, the first display screen will list all devices and require a selection before the “Online” display is shown. Follow the HART DD menu on the previous page to navigate.

NOTE: If the communicator is unable to communicate with the DCM-3, it displays the message, “No Device Found”. If this occurs, check to make sure the leads are securely connected to the Demand wiring and retry. If communications still do not occur, the communicator polling setup may be improperly set. Check the “utility” menu and make sure communications polling is set to “always poll”.

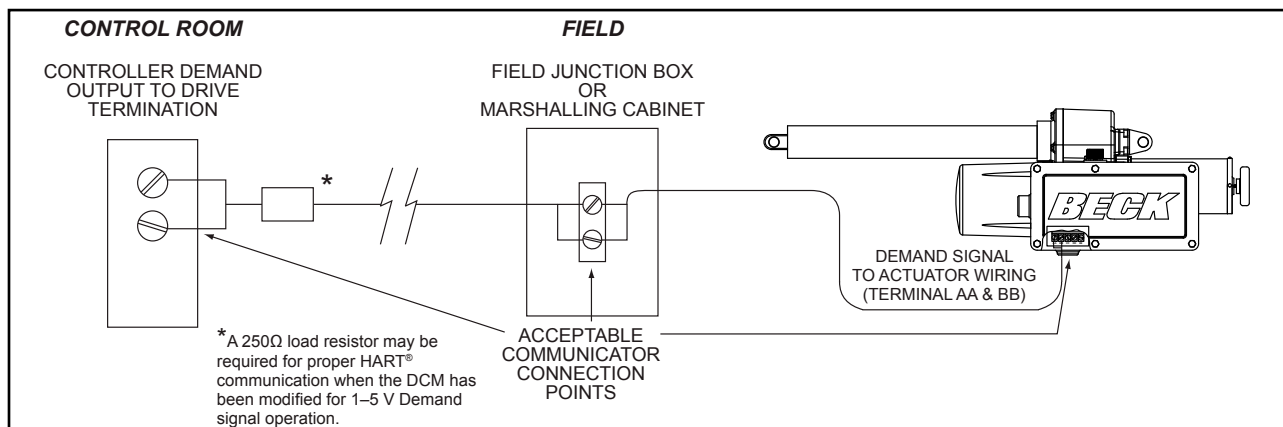

MENU DESCRIPTIONS

(See HART Communicator Menu on page 43)

MENU 1 -- Online

When communications are established with the communicator, the Online menu is displayed.

- 1 Functions:** The link to the menu tree.
- 2 Position:** The output shaft position displayed as a percent of range.

- 3 Demand:** The Demand signal displayed as a percent of range.
- 4 Loop (Dem):** The Demand signal measured in mA.
- 5 Trq/Thrust:** The present thrust value as applied to the output shaft.
- 6 Temp:** The ambient temperature of the DCM-3.
- 7 Feedback:** Milliamp output signal representing the present position of the output shaft.

MENU 2 -- Functions

From the Functions menu, any of the DCM-3 functional menus can be selected and accessed. There are seven functional areas: Setup Checklist, Device Information, Configuration, Statistics, Manual Operation, Diagnostics, and Calibration Trim.

MENU 3A -- Setup Checklist

The Setup Checklist provides a quick way to setup the most important items necessary for basic actuator operation without having to move through multiple sub-menus. These items are defined on the following pages in their specific menu locations.

MENU 3B -- Device Information

The Device Information menu provides information about the actuator. There are ten useful information entries that may be viewed and/or edited.

- 1 Tag:** An 8 character entry that can be used to identify a specific field device label.
- 2 Descriptor:** A 16 character field that can be used to provide any description desired.
- 3 Message:** A 32 character field that can be used to provide any message desired.
- 4 Model#:** Displays the model number of the actuator in which the DCM-3 is installed. This field may be edited. Note that changing this field may cause the "Use Default Setup" command to not function.
- 5 Drive S/N:** The Serial number as shown on the actuator nameplate.
- 6 InstId:** Installation date of the DCM-3.
- 7 Setup:** The setup date has no affect on actuator operation.
- 8 Calbrtd:** The calibration date has no affect on actuator operation.
- 9 Review:** Link to the Review menu.
- 10 Poll addr:** Used to find the actuator. Most configurations should use "0".

MENU 3C -- Configuration

The Configuration menu serves as the gateway to all of the actuator operating parameters that can be used to configure the actuator based on the desired operation.

- 1 General Setup:** Link to General Setup menu.
- 2 PositionSensrSetup:** Link to PositionSensrSetup menu.

- 3 Demand Setup:** Link to Demand Setup menu.
- 4 Feedback Setup:** Link to Feedback Setup menu.
- 5 Thrust Setup:** Link to Thrust Setup menu.
- 6 Restore to Factory:** Restores field-configurable parameters back to the settings in effect when the DCM-3 was shipped from the factory.
- 7 Use Default Setup:** Changes the DCM-3 position sensing voltage ranges to the proper ranges for the actuator model.

MENU 4B -- General Setup

This menu sets actuator operating parameters. The nine parameter entries are as follows:

- 1 Drive Dir:** The direction the output shaft moves in response to an increasing Demand signal.
- 2 MaxTravel:** The maximum available travel distance of the output shaft in inches. This number corresponds to the actuator design—if the correct Serial Number is entered, this parameter should not be changed.
- 3 Travel:** The number of inches of output shaft travel for 100% span.
- 4 StepSize:** The smallest Demand change that will cause an output shaft movement.
- 5 Stall Time:** The amount of time the motor will run before Stall Protection is initiated.
- 6 StallProt:** This entry is set as either "Enabled" or "Disabled".
- 7 LimitSwitch:** This entry is set as either "Accept" or "Alert" and defines whether or not contacting an overtravel limit switch outside of the normal 0% to 100% travel range will cause an alarm condition.
- 8 PositionUnit:** The numeric unit of measure for the output shaft position (inches).
- 9 Temperature Unit:** The unit of measure for temperature sensing. May be "degF" (fahrenheit) or "degC" (celsius).

MENU 4C -- PositionSensrSetup

This menu contains parameters that determine how the DCM-3 interprets the output shaft position signal from the CPS-4.

- 1 Set Pos 0%:** Sets the 0% position to match the present output shaft position. This does not change the 100% position.

APPENDIX HART[®] Communication

- 2 Set Pos 100% Span:** Sets the 100% position to match the present output shaft position. Also instructs the DCM-3 to change "Travel" span based on the 0% position. This does not change the 0% position.
- 3 PresCPS V:** Displays the CPS-4 signal voltage at the present output shaft position. Not editable.
- 4 CPS Zero%:** Displays the CPS-4 voltage at the 0% output shaft position. May be edited to define the voltage at the lowest operating point of travel.
- 5 CPS Span:** Displays the voltage signal span from the CPS-4 for maximum possible rotation of the output shaft. This is the upper range voltage minus the lower range voltage. Not editable.
- 6 CPS RngLwr:** Displays the CPS-4 voltage signal at the lowest possible point of travel. Not editable.
- 7 CPS RngUpr:** Displays the CPS-4 voltage signal at the highest possible point of travel. Not editable.
- 8 Pos S/N:** Displays the Serial number of the CPS-4 and has no effect on actuator function.
- 9 Snsr Dir:** The direction of output shaft movement that causes the CPS-4 signal to increase. This direction is typically "Ext Incr" (signal increases as output shaft extends) and is not editable.

MENU 4D -- Demand Setup

The parameters on this menu determine the range and characterization of the Demand signal. It also includes parameters that determine behavior when the Demand signal is absent.

- 1 DemRngLwr:** Sets and displays the signal value in mA that represents 0% Demand (default is 4.00 mA, minimum is 0.5 mA). This value should be set above "DemLimLwr".
- 2 DemRngUpr:** Sets and displays the signal value in mA that represents 100% Demand (default is 20.00 mA, maximum is 21.00 mA). This value should be set below "DemLimUpr".
- 3 Dem Curve:** Determines the relationship between the Demand signal and the position of the output shaft. Typically set to Linear, but may also be set to Square, Square Root or customized Special Curve.
- 4 Dem Curve Spcl:** Link to the "Dem Curve Spcl" menu.
- 5 LOS Mode:** Action on loss of Demand signal.
- 6 LOS Pos:** If the "LOS Mode" has been set to "Go-to-Pos", this defines where the output shaft will move (in percent of travel) during loss of Demand signal conditions.
- 7 DemLimLwr:** Sets the threshold (in mA) below which the Demand signal is considered lost. This value should be set below "DemRngLwr".
- 8 DemLimUpr:** Sets the threshold (in mA) above which the Demand signal is considered invalid. The Demand alarm will activate until the signal is brought below this level. This value should be set above "DemRngUpr".

MENU 5A -- Dem Curve Spcl

This menu allows setting the Demand signal characterization curve.

MENU 4E -- Feedback Setup

This menu is where all the Feedback signal related actuator parameters are set.

- 1 FBRngLwr:** The value of the Feedback signal (in mA) that corresponds to a 0% output shaft position. This value can range between 3.00 mA and 16.00 mA (default = 4.00 mA).
- 2 FBRngUpr:** The value of the Feedback signal (in mA) that corresponds to a 100% output shaft position. This value can range between 7.00 mA and 21.00 mA (default = 20.00 mA).
- 3 Feedback:** Enables or Disables the Feedback signal.
- 4 FB Curve:** Allows a choice between a Feedback signal that linearly represents true shaft position or a characterized Feedback signal that inverts the effect of a characterized Demand signal.

MENU 4F -- Thrust Setup

This menu is where thrust-related actuator parameters are set.

- 1 Trq/Thrust:** Enables or disables thrust sensing.
- 2 Ovt Prot:** Enables or disables overthrust protection which will remove power from the motor if excessive thrust is detected.
- 3 AlarmLevel:** Sets the value that, if exceeded, will cause the Thrust Alarm to activate.
- 4 ShutDwnThr:** Sets the output shaft thrust in percentage of actuator rating that, if exceeded, removes power from the motor.
- 5 Thr Null:** The thrust sensor value that represents 0% output shaft thrust.

6 Thr Const: The internal DCM-3 signal span associated with the output shaft thrust. This value is determined during manufacture and is noted on a label inside the DCM-3 cover.

MENU 3D -- Statistics

This menu is where all the actuator's stored operating statistics are available.

- 1 Starts:** The total number of motor starts.
- 2 Reversals:** Total number of times the motor has started in the direction opposite to the previous start.
- 3 Stalls:** Total times stall time was exceeded.
- 4 OverThrusts:** Logs and displays the total number of times the that excessive thrust was detected at the output shaft.
- 5 Pk Thrust:** Logs and displays the maximum thrust sensed at the output shaft.
- 6 TotRunTm:** Total amount of time the motor has been powered (in seconds).
- 7 High Temp:** Highest temperature recorded in the DCM-3 compartment (in degrees fahrenheit).
- 8 Low Temp:** Lowest temperature recorded in the DCM-3 compartment (in degrees fahrenheit).

MENU 3E -- Manual Operation

This menu is used to allow manual operation using HART® communications. There are three manual operation procedures available:

- 1 Op mode (Menu 4G):** Selects the operating mode of the DCM-3. There are six possible choices: "Follow", "Hold", "RunRET", "RunEXT", "Stay" and "Stop". "Follow" mode is the normal state of operation and allows the DCM-3 control in response to the analog input Demand signal. "Hold" mode forces the DCM-3 to position according to the HART Demand value (see right). "RunRET" mode forces the actuator to retract. "RunEXT" forces the actuator to extend. The "Stay" mode forces the actuator to maintain its present position. Note that in "Stay" mode, the Handwheel cannot be freely turned. The "Stop" mode removes power from the motor. Note that in "Stop" mode the Handwheel can be freely turned. Note that the Handswitch overrides all operating modes.
- 2 Demand:** This procedure sets the effective Demand signal. If "Op mode" is set to "Hold", entering a valid value (-5% to 105%)

will control the motor. If "Op mode" is set to "Follow", the analog Demand signal is displayed (unless an alarm condition exists).

- 3 Reset Stall:** This procedure resets normal actuator operation after a stall condition has caused the motor to shut down. Note that stall conditions can also be reset by simply reversing the input Demand signal or cycling the actuator AC power.

MENU 3F -- Diagnostics

Provides access to all DCM-3 stored diagnostic information concerning actuator operation.

MENU 4H -- Status

This menu provides links to menus that monitor the operational status of the actuator. It also displays one parameter, line frequency.

- 5 Line Freq:** Power line frequency as measured by the DCM-3.

MENU 5B -- LED Status

The LED Status parameter allows remote checking of which LED's on the DCM-3 are illuminated.

MENU 5C -- Operating Status

The Operating Status parameter is a summary of whether process-related conditions are inside or outside of anticipated limits. These conditions control the Status Indication LEDs.

- 1 Demand:** Caused by the Demand signal falling below or above acceptable levels.
- 2 Position:** Caused by the CPS-4 signal being outside the range anticipated by the DCM-3.
- 3 Temperature:** The ambient temperature of the DCM-3 is outside of the rating.
- 4 Thrust:** Warns that thrust is high.
- 5 Ovr Thrust Stop:** Motor power has been removed due to excessive thrust.
- 6 Stalled:** A Stall alarm is active.
- 7 Feedback Open:** The Feedback signal is enabled, but cannot follow the proper current.
- 8 Switch Block:** The DCM-3 cannot power the motor due to an electro-mechanical switch. Check the Handswitch and over-travel limit switches.

APPENDIX HART[®] Communication

MENU 5D -- Switch Status

This menu displays the ON or OFF status of the eight switch parameters: LV Lim EXT, LV Lim RET, OvrRd EXT, OvrRd RET, OvrRd Stop, HndSw EXT, HndSw RET, and HndSw AUTO. The Switch Status menu displays the status of the RET/EXT control override input, the STOP control override or if the Handswitch is in the RET/EXT or AUTO position.

MENU 5E -- Local Cntrl Status

This parameter allows remote monitoring of which buttons on the local configuration interface are being pressed.

MENU 5F -- RET Inhibitors

This menu displays the ON or OFF status of the contributing sources of retract movement inhibitors of motor operation: Balance, Supervisory, Stall, OverTrq/Thr, Switch Block, Bad Pos Sig, Bad Dem Sig, Local Cal. See below.

CONDITION	DESCRIPTION
Balance	"ON indicates that the Demand and Position are at balance"
Supervisory	"ON indicates that the DCM is initializing"
Stall	"ON indicates a stall condition"
OverTrq/Thr	"ON indicates that the motor is stopped due to excessive torque or thrust"
Switch Block	"ON indicates that the Handswitch, Override, or Limit Switch is inhibiting movement"
Bad Pos Sig	"ON indicates that the Position signal is out of range"
Bad Dem Sig	"ON indicates that the Demand signal is out of range"
Local Cal	"ON indicates that a Local Calibration button is pressed"

MENU 5G -- EXT Inhibitors

This menu displays the ON or OFF status of the contributing sources of extend movement inhibitors of motor operation: Balance, Supervisory, Stall, OverTrq/Thr, Switch Block, Bad Pos Sig, Bad Dem Sig, Local Cal. See table above.

MENU 4I -- Tests

Provides access to some routines that help determine if the actuator is functioning properly.

- 1 FB Out Test:** Allows manual verification of the Feedback output signal to check operation and accuracy.
- 2 Board Self-Test:** Instructs the DCM-3 to check various power and sensing circuits. This test will cause the actuator to reposition, so it should be run offline and only when a DCM-3 problem is suspected.
- 3 Identify Device:** Causes the ACKNOWLEDGE LED on the DCM-3 to flash for two seconds. Ensures HART is addressing the correct actuator.
- 4 Board Reset:** Causes the DCM-3 to initiate a reset cycle similar to a power-up reset. This manual reset will cause the actuator to reposition. This procedure is not typically necessary.

MENU 4J -- RET Thrust

This menu displays the peak output shaft thrust measured for 10 segments. These thrust values are measured with the motor running and retracting the output shaft.

MENU 4K -- EXT Thrust

This menu displays the peak output shaft thrust measured for 10 segments. These thrust values are measured with the motor running and extending the output shaft.

MENU 4L -- Alarm Setup

The Alarm Setup menu parameters allow modification of the behavior of the alarm.

- 1 AlarmPol:** Whether the solid state relay opens on alarm or closes on alarm.
- 2 Alarm Mask:** Link to the Alarm Mask menu which allows specific alarm conditions to be ignored.

MENU 5H -- Alarm Mask

Allows selection of alarm conditions that will not cause an alarm at terminal E.

MENU 4M -- RealTimeClock

This menu allows the date and time to be set.

- 1 RTC Day:** Day of the month (numeric value).
- 2 RTC Month:** Month (numeric value).
- 3 RTC Year:** Year (4 digits).
- 4 Hour (24):** Hour of the day (24 hour format).
- 5 Minute:** Minute of the hour (0 through 59).

MENU 3G -- Calibration Trim

The Calibration Trim menu sets and displays actuator calibration values. **Note that changing the calibration trim can cause signal measurement difficulties if performed improperly.**

- 1 PresCPS V:** Displays and/or trims the present voltage of the position signal. This value may also be measured at DCM-3 test points TP1(-) and TP4(+). This trim is set and tested at the factory. Changing this value can cause voltage measurement errors.
- 2 Loop(Dem):** Displays the Demand signal as measured at the field wiring terminals. When the Demand control loop signal is being overridden by a special mode of operation, the effective Demand will not correspond to the mA value. This value can be edited to trim the Demand to ensure accurate measurement of the analog signal. Demand can only be trimmed at 4.0 mA and 20.0 mA.
- 3 Feedback:** Displays the mA signal representing the output shaft position as measured at the field wiring terminals. This value can be edited.
- 4 Trq/Thrust:** Displays the load measured at the output shaft as a percentage. This is also a short cut to set the 0% thrust parameter ("Thr Null") by removing load from the output shaft, then writing a "0" to this value.

APPENDIX HART[®] Communication

COMMON HART[®] MESSAGES

HART[®] protocol maintains both standard and device specific informational messages that are displayed on the Communicator when various conditions occur.

Below is a table of typical Beck messages and message sequences. It does not include all possible messages, only the most common.

Output Shaft Position Measurement Messages

Message	Description
"Process applied to the primary variable is outside the operating limits of the field device."	This is a standard HART-defined message that appears whenever the HART primary variable (Position signal) is outside the design or calibrated range. This message should be accompanied by a Beck-specific message with more detail.
"The Position Signal is less than -5% or greater than 105%."	This Beck-specific message indicates the DCM-3 is reading a Position signal not within the calibration range limits.
"Position signal in LOS."	This is a Beck-specific message. The DCM-3 is indicating that the Position signal is a problem and is intended to identify a CPS-4 or wiring failure. This is triggered when the Position signal is outside the minimum and maximum voltage limits.
"Position out of accurate measurement range."	This is a Beck-specific message. The DCM-3 indicates the Position signal is outside of the design range.
"Position sensing error."	This is a Beck-specific message. The DCM-3 circuitry for measuring the Position signal does not appear to be functioning properly.
"Analog output 1 and its digital representation are outside the operating range limits, and not responding to input."	This is a standard HART-defined message that appears whenever the position signal to the DCM-3 is outside the design or calibrated range. This message should be accompanied by a Beck-specific message with more detail.

Handswitch and Over-travel Limit Switch Message

Message	Description
"Motor power is blocked, check switches."	This message will appear if the DCM-3 detects a condition that prevents current flow to the motor.

Stall Protection Message

Message	Description
"Stall condition has been detected (see 'Stall Time' in the 'General Setup' menu)."	This is a Beck-specific message indicating that the actuator is in a stalled condition. This occurs if the actuator cannot reach the Demand position in the time allotted by the stall time setting (configurable from 30–300 seconds).

Demand, Thrust and Temperature Measurement Messages

Message	Description
"Process applied to the non-primary variable is outside the operating limits of the field device."	This is a standard HART-defined message that appears whenever the Demand signal or Temperature are outside their design or calibrated ranges. This message should be accompanied by a Beck-specific message with more detail.
"The Demand Signal is outside of the intended limits (see Demand Setup menu)."	This Beck-specific message indicates the Demand signal is invalid.
"Demand out of accurate measurement range."	This is a Beck-specific message that the Demand signal is not only out of the calibrated range, but also out of the design range of the actuator. The lower and upper limits are 0.1 V dc and 5.5 V dc, respectively. Note that current input DCM-3 boards utilize a 250 Ohm input resistor to convert the current signal to voltage.
Demand Signal is out of limit.	This Beck-specific message indicates the Demand signal is too high to measure accurately. The upper limit is 5.5 V dc. Note that current input DCM-3 boards utilize a 250 Ohm input resistor to convert the current signal to voltage.
Demand sensing error.	This is a Beck-specific message. The Demand sensing circuitry does not appear to be functioning properly.
The Torque/Thrust is greater than the output rating.	This Beck-specific message defines an output shaft thrust overload problem.
Motor power has been removed due to excessive output thrust.	This Beck-specific message indicates the DCM-3 has removed power from the motor due to excessive output shaft thrust load. The Handswitch must be in AUTO mode for this alarm to be accurate.
Torque/Thrust out of accurate measurement range.	This is a Beck-specific message. The DCM-3 is not able to read a valid signal from the Thrust sensor.
Torque/Thrust sensing error.	This is a Beck-specific message. The DCM-3 circuitry for measuring the Thrust signal does not appear to be functioning properly.
The temperature is outside of -40°F to 185°F.	This is a Beck-specific message indicating that the temperature at the DCM-3 is outside of the acceptable range.
Temperature out of accurate measurement range.	This is a Beck-specific message. The DCM-3 ambient temperature reading is extreme and cannot be accurately measured.
Temperature A/D Fail.	This is a Beck-specific message. The DCM-3 circuitry for measuring the ambient temperature does not appear to be functioning properly.
The Feedback Signal is enabled but the loop is open.	This is a Beck-specific message indicating that the Feedback sourcing circuit is unable to create the proper signal current. This message could result from the signal not being wired to an external load, or a wiring failure has occurred at some point between the actuator and the monitoring device.

APPENDIX HART[®] Messages

Questionable Configuration Messages

Message	Description
Analog output 1 and its digital representation are in fixed mode, and not responsive to input changes.	Standard HART-defined message that appears whenever the Feedback signal has been manually assigned a value. This message should be accompanied by a Beck specific message with more detail.
Feedback is in fixed mode.	A Beck-specific message indicating that the Feedback signal has been manually set to a fixed value and is not following the Position value.
Local control button pressed while locked-out.	A Beck-specific message indicating an incorrect combination of pushbuttons is being pressed on the local configuration interface, or the local control interface is disabled and a pushbutton is being pressed.
Loop Current Detected while under HART/FF Control.	A Beck specific alarm message that alerts the user that analog current is present on the Demand terminals, but the DCM-3 is in an Op Mode expecting digital control. Make certain the Op Mode parameter is set properly.
Loop Current Detected while set for LOS PAT.	A Beck specific alarm message that alerts the user that analog current is present on the Demand terminals, but the DCM-3 is set to a LOS mode intended to be used without an analog signal.

DCM-3 Failure Messages

Message	Description
Real-time Clock hardware failure.	This is a Beck-specific message. The data in the Real-time Clock appears invalid.
FRAM Memory has failed.	A Beck-specific message. The continuous built-in self-test cannot verify the memory for statistics information is operating properly.
Memory failure.	This is a Beck-specific message. The continuous built-in self-test cannot verify the microcomputer is operating properly.

Miscellaneous HART-Defined Messages

Message	Description
Field device has more status available.	This is a standard HART-defined message that appears whenever the DCM-3 signals the HART master that an alarm or other undesirable status exists. This is the HART protocol mechanism for displaying the other messages in this section. If this message is displayed without an additional message, the status cleared before the HART master read the additional status.
A reset or self-test of the field device has occurred, or power has been removed and reapplied.	This message is presented by the HART master if the DCM-3 has gone through a power-up reset sequence since the last communication with the master. This message is only displayed once after a reset.
A modification has been made to the configuration of the field device.	This message indicates that the DCM-3 has undergone a configuration change since the last time the HART master has reset the change flag. Many HART masters disregard the flag and do not report this message.
Field device has malfunctioned due to a hardware error or failure.	This message indicates that the continuous built-in self-test cannot verify the microcomputer is operating properly.

APPENDIX Serial Communication

COMMUNICATIONS

Local configuration of the Beck actuator can be accomplished using Serial commands through the DCM-3 Serial port.



CAUTION

Changes made to the actuator through Serial communications may not necessarily be reflected in asset management systems. Be sure to verify any changes made serially and make manual corrections to the asset management system if necessary.

The Beck Digital Control Module (DCM-3) is equipped with a Serial interface which allows for direct communication with a computer. Using a standard DB9 to USB cable, connect the DCM-3 to the computer using the DCM-3's DB9 connector (see below for location) and one of the computer's USB ports. Note: If your computer is equipped with an active COM port, a DB9 to DB9 cable may be utilized, if preferred (available for purchase from Beck, see below).

Once connected, communication can be established between the DCM-3 and the computer using a terminal emulation program, such as HyperTerminal®. This method of communication will allow for configuration, calibration and verification of actuator DCM-3 settings without the use of custom software applications.



DB9
Connector

NOTE: Layout may vary slightly depending on DCM version.

Hyperterminal® is a product of Hilgraeve, Inc.

HyperTerminal® SOFTWARE

HyperTerminal is the standard ASCII terminal emulation software provided with Microsoft® Windows®. If using HyperTerminal®, the following instructions will assist in setup. Note that some variation to these instructions may be necessary depending on the version of HyperTerminal® being used.

After connecting the DCM-3 to the (Windows®-based) computer, access HyperTerminal® by clicking first on "Start", then "Programs", then "Accessories", then "Communications", then "HyperTerminal". Double-click on the "Hypertrm.exe" icon to start the program. Once HyperTerminal® is running, it is necessary to set up a file with the proper settings to communicate with the DCM-3. Proceed as follows:

1. If prompted to install a modem, answer "no". Proceed to enter a name (e.g., "DCM-3") and select an icon (any will suffice) in the "Connection Description" box. Click the "OK" button.
2. The "Connect to" box should open next. At the bottom of the box, set the "Connect using" selection to the appropriate USB (or COM) port that has been connected to the DCM-3. Click the "OK" button.
3. The COM port properties box should open next; this is where the communication settings are established. The correct settings are:
 - a. Bits per second = "1200"
 - b. Data bits = "8"
 - c. Parity = "none"
 - d. Stop bits = "1"
 - e. Flow control = "none"
4. With the appropriate settings entered from Step 3, above, click "OK". Communications should now be enabled.
5. Press the "Enter" key twice. "OK" should be displayed indicating that HyperTerminal® is communicating with the DCM-3.

Beck Serial Communications Cables



DB9 to USB-A
P/N 20-0511-60



DB9 to DB9
P/N 20-0511-14

*Note cables may differ in appearance from depiction.

APPENDIX *Serial Commands*

COMMANDS AND ARGUMENTS

Commands can be used for a variety of functions including changing the operating configuration of the actuator, verifying operation settings, calibration and accessing diagnostic information. There are essentially four different types of commands:

1. Dual-purpose commands. These commands can be used to either modify actuator configuration settings or display the settings already set in the actuator. In order to set or make a change to the settings, the command requires an argument (*n*). If the command is used for display purposes only, the argument is omitted. Examples of these commands include "temperature" and "demlos".
2. Display only commands. These commands are used to display diagnostic or operating information such as present signal values. No arguments are required. Examples include the "stat" command and the "signals" command.
3. Set only commands. These commands serve only to make a parameter change. Typically, they apply to the actuator calibration. This type of command requires an argument, but unlike dual-purpose commands, they return an error message when entered without an argument. Examples include the "charset" and "trimfdbk4mA" command.
4. Execute action commands. These commands serve to reset, enable or disable features. Entering these commands produces an immediate action. Examples include the "reset" and "restoremodes" command.

The available commands are listed on the next several pages and each is described in detail. The command description explains the use or uses of the command, while the argument column describes any applicable arguments. Arguments are denoted as *n*. Note that the commands described as "sets and/or displays" signify dual-purpose commands that can be used with or without an argument for setting or verifying configuration settings.

SERIAL COMMANDS

The following is a categorized list of Serial commands available through the RS-232 interface. These commands are described in detail on the pages that follow.

Output Shaft Position Sensing Commands

cpsvat0pct	travel
------------	--------

General Configuration Commands

alarmout	restoremodes
alarmoutmask	sernum
configformodel	stallprot
drvdir	stalltime
limitalarm	stepsize
opmode	

Thrust Sensing Commands

ovtstop	thrustalarm
ovtstoplevel	thrustconst
thrust	thrustenable
thrust0k	thrustprof
thrust0pct	

HART[®] Configuration Commands

harttype	polladdr
----------	----------

Diagnostic and Information Commands

demsorce	signals
help	stat
ledtest	temperature
reset	uninstall

Demand Signal Commands

dem0pctma	demlostgtp delay
dem100pctma	trimdem4ma
demlos	trimdem20ma
demlostgtp	

Demand Characterizer Commands

charclear	charset
charlist	demfunc

Feedback Signal Commands

fdbk0pctma	trimfdbk4ma
fdbk100pctma	trimfdbk20ma
fdbkfunc	iomode

Output Shaft Position Sensing Commands

Command	Description	Argument <i>n</i> and Information
cpsvat0pct <i>n</i>	Sets/displays the DCM-3 voltage setting used to determine 0% signal from the CPS-4. Voltage is dependent upon the actuator model. Typically, this setting does not need to be changed.	<i>n</i> = desired voltage as a decimal (carried out to 3 decimal places). The standard signal range for an actuator configured for 100 degrees of output shaft rotation is approx. 1.000–4.000 V.
travel <i>n</i>	Sets/displays the number of degrees that represents 100% travel. This command does not shift the 0% position; when increasing travel from a reduced travel setting, the 0% position may need to be changed first to keep travel within acceptable end points. The end points are defined by the CPS-4 voltage range.	<i>n</i> = desired length of travel in degrees. This value cannot exceed the maximum output shaft rotation of the actuator.

APPENDIX Serial Commands

General Configuration Commands

Command	Description	Argument <i>n</i> and Information
alarmout <i>n</i>	Sets/displays the polarity of the alarm output solid state relay.	<i>n</i> = "0": open on Alarm <i>n</i> = "1": closed on Alarm Upon loss of power, the relay is open regardless of the setting.
alarmoutmask <i>n</i>	Sets/displays (in hexadecimal format) which conditions will cause an alarm: 0x00000001 - Demand Loss of Signal 0x00000002 - Thrust High 0x00000004 - Stall Condition 0x00000008 - Thrust Stop 0x00000010 - Stop/Limit 0x00000020 - Feedback Loss of Signal 0x00000040 - Temperature too High/Low 0x00000080 - Position Outside of Limits 0x00000100 - Real-time Clock Failure 0x00000200 - Thrust Measurement Failure 0x00000400 - Position Analog/Digital Circuit Failure 0x00000800 - Demand Measurement Failure 0x00002000 - Position Loss of Signal 0x00004000 - Temperature Measurement Failure 0x00008000 - Memory Failure 0x00010000 - Invalid Button Pressed 0x00020000 - Demand too High	<i>n</i> = "0x0": no listed condition causes a status alarm <i>n</i> = "0xffffffff": all listed conditions cause a status alarm <i>n</i> = hexadecimal value for specific condition(s) which will cause an alarm. Multiple conditions may be selected by performing a hexadecimal addition of the condition values; e.g., Stall Condition and Thrust Stop alarms -- hex 0x04 + 0x08 = 0x0C.
configformodel <i>n</i>	Sets certain DCM-3 default values based on the actuator Serial number. These values are direction rotation for an increasing CPS-4 signal, expected range of CPS-4 signal, and the maximum travel.	<i>n</i> = "1": executes command
drvdir <i>n</i>	Sets/displays the actuator output shaft direction resulting from an increasing Demand signal.	<i>n</i> = "0": extend <i>n</i> = "1": retract
limalarm <i>n</i>	Sets/displays alarm action if the actuator travels outside of the electronic limits and contacts an over-travel limit switch.	<i>n</i> = "0": mute (no alarm) <i>n</i> = "1": always
opmode <i>n</i>	Sets/displays the mode that controls the Demand signal source. This mode selects analog or digital control.	<i>n</i> = "0": analog Demand <i>n</i> = "1": digital Demand <i>n</i> = "2": extend <i>n</i> = "3": retract <i>n</i> = "4": stay <i>n</i> = "5": stop
restoremodes <i>n</i>	Returns the DCM-3 settings to the original factory configuration.	<i>n</i> = "1": executes command
sernum <i>n</i>	Sets the actuator serial number.	<i>n</i> = serial number
stallprot <i>n</i>	Sets/displays stall protection state.	<i>n</i> = "0": disabled <i>n</i> = "1": enabled
stalltime <i>n</i>	Sets/displays time the actuator runs in one direction before stall alarm is activated.	<i>n</i> = seconds: acceptable range is 30–450 seconds.
stepsize <i>n</i> %	Sets/displays the size of one incremental movement of the output shaft.	<i>n</i> = % of travel desired: acceptable range is 0.10%–2.5%. Include the "%" symbol after the number, otherwise the unit of measure will be inches.

Thrust Sensing Commands

Command	Description	Argument <i>n</i> and Information
ovtstop <i>n</i>	Sets/displays whether motor power will be removed during severe overthrust conditions. Thrust sensing must be installed and enabled.	<i>n</i> = "0": disabled <i>n</i> = "1": enabled
ovtstoplevel <i>n</i>	Sets/displays the thrust magnitude associated with severe output shaft thrust conditions.	<i>n</i> = allowable thrust magnitude (without stopping motor) in percent of actuator rating. May be set from 25% to 150% (factory set to 150%).
thrust	Displays the thrust on the output shaft measurement as a percentage of actuator rating. Also displays related values such as thrust0k and thrustconst.	No argument.
thrust0k <i>n</i>	Sets/displays the value of DCM-3 internal measurement corresponding to 0% thrust on the output shaft.	<i>n</i> = the zero thrust value in counts (noted on label inside DCM-3 cover).
thrust0pct <i>n</i>	This is an alternate method for setting thrust0k, and is useful when the correct thrust0k value is not already known. To use this command, remove all load from the output shaft, then execute thrust0pct with argument "0" to let the DCM-3 know that the thrust sensing should be reading 0%.	<i>n</i> = "0"
thrustalarm <i>n</i>	Sets and/or displays the thrust magnitude associated with the first level of alarm.	<i>n</i> = allowable thrust magnitude without alarm, in percent of actuator rating.
thrustconst <i>n</i>	Sets/displays the value of DCM-3 internal measurement corresponding to the thrust span (the measurement at 100% minus the measurement at 0%).	<i>n</i> = the thrust span value in counts (noted on label inside DCM-3 cover).
thrustenable <i>n</i>	Sets/displays the enabled or disabled status of thrust sensing.	<i>n</i> = "0": disabled <i>n</i> = "1": enabled
thrustprof	Displays a three table column: 1. Maximum travel divided into 10 segments 2. peak thrust measured in each segment with motor extending the output shaft 3. peak thrust measured in each segment with motor retracting the output shaft.	No argument.

HART® Configuration Commands

Command	Description	Argument <i>n</i> and Information
harttype <i>n</i>	Sets/displays the DCM-3 HART DD (Device Description). "239" is the proper DD; other DDs are for temporary use if the new DD is not available.	<i>n</i> = "1": ESR-D <i>n</i> = "10": Beck DCM <i>n</i> = "239": Beck MK2
polladdr <i>n</i>	Sets/displays the polling address used by the HART master to find individual devices if the HART bus has more than one device.	<i>n</i> = the polling address (a number between "0" and "15"). Unless multiple HART devices are connected in parallel on a single bus, the polling address should be set to "0".

APPENDIX Serial Commands

Diagnostic and Information Commands

Command	Description	Argument <i>n</i> and Information
demsources	Provides a readout of information regarding the Demand on the actuator including the source of the Demand signal (Handswitch, demlos or Analog I/P), mode (Follow, Hold, Extend, Retract, Stay or Stop), currently applied Demand signal as a %, the Demand function (linear, square root, square, or special), and the Demand out as a % (dem out shows the signal adjusted when using a non-linear Demand function (demfunc command)).	No Argument
help <i>n</i>	Displays help text for a specific command or lists all available Serial commands.	<i>n</i> = command name <i>n</i> = "all"
ledtest <i>n</i>	Tests the functionality of the DCM-3 LEDs individually or as a group. If "all" is selected, the command will consecutively cycle through each LED twice. If an individual LED is selected, it will flash 12 times.	<i>n</i> = "1": DEMAND <i>n</i> = "2": POSITION <i>n</i> = "3": TRQ/THRUST <i>n</i> = "4": STALL <i>n</i> = "5": TEMP °F <i>n</i> = "6": FB OPEN <i>n</i> = "7": STOP/LIMIT <i>n</i> = "8": ACKNOWLEDGE <i>n</i> = "100": FWD <i>n</i> = "101": REV <i>n</i> = "102": STAT <i>n</i> = "All"
reset <i>n</i>	Performs the same reset sequence as when power is removed and reapplied.	<i>n</i> = "1": must equal "1" for command to execute.
signals	Displays the present DCM-3 readings of four signals: Position signal from CPS-4 Demand Feedback Thrust	No argument = signal readings are displayed. <i>n</i> = "all": an extended set of data is displayed.
stat	Displays information on the status of the actuator, including: Time / Date, Demand, Position, Error (Demand minus Position), Step size, Dead band, Motor Status, Motor Run Time, Line Frequency, Motor Starts, Motor Reversals/Stalls, Number of Overthrust conditions, Positive & Negative Peak Thrust (%), EXT and RET Inhibitor Status, Alarms	No argument
temperature <i>n</i>	Displays three values describing the ambient temperature in the actuator. Low extreme, present, high extreme. Can also change the temperature units.	No argument = temperatures are displayed. <i>n</i> = "F": changes units to Fahrenheit <i>n</i> = "C": changes units to Celsius
un stall	Resets the Stall Protection alarm to restore power to the motor. If the motor is still physically stalled, the Stall Protection alarm will recur.	No argument.

Demand Signal Commands

Command	Description	Argument <i>n</i> and Information
dem0pctma <i>n</i>	Sets/displays the Demand signal value that corresponds to 0% actuator position.	<i>n</i> = Demand signal as a decimal in mA. Minimum value is 0.50; maximum value is 100% Demand less 4.00 mA (e.g., if 100% Demand is 20.00 mA, the 0% value must be set for 16.00 mA or less).
dem100pctma <i>n</i>	Sets/displays the Demand signal value that corresponds to 100% actuator position.	<i>n</i> = Demand signal as a decimal in mA. Minimum value is 0% Demand plus 4.00 mA (e.g., if 0% Demand is 4.00 mA, the 100% value must be set for 8.00 mA or greater). Maximum value is 21.00 mA.
demlos <i>n</i>	Sets/displays the Demand signal threshold, below which the DCM-3 recognizes the signal has been lost. The threshold is entered as a value in mA. This command also sets/displays the action initiated by the actuator during LOS (Loss Of Signal). LOS action options are "sip" (stay in place) or "gtp" (go to position). Demlos always reports both settings, but only sets one argument at a time. Demlos must be used twice to set both the threshold and action.	<i>n</i> = Demand signal in mA below which LOS occurs (e.g., the typical value for a 4–20 mA system is 3.20). -OR- <i>n</i> = "sip", "gtp" or "pat". The "pat" argument acts the same as "sip", but also suppresses the alarm--this is used in some pulsed applications.
demlosgtp <i>n</i>	Sets/displays the position to which the actuator will run upon loss of the Demand signal (LOS). This command has no effect if the actuator is set to "sip" (stay in place).	<i>n</i> = desired position of actuator expressed as a percentage of actuator travel in decimal form (e.g., 50% = 50.00).
demlosgtp delay <i>n</i>	Sets the time delay in seconds before the actuator will move to the position set in "demlosgtp". Entering this command without an argument will return the present gtp and delay settings.	<i>n</i> = time delay in seconds. Acceptable values are 0 (default) to 25.5.
trimdem4ma 4	Trims the Demand analog-to-digital sensing circuit to be accurate at 4 mA. This command should only be used when the Demand signal at the actuator is exactly 4.0 mA. Trim is factory set and should not normally require recalibration.	"4" is the only acceptable value; this trim can only be performed at 4 mA.
trimdem20ma 20	Trims the Demand analog-to-digital sensing circuit to be accurate at 20 mA. This command should only be used when the Demand signal at the actuator is exactly 20.0 mA. Trim is factory set and should not normally require recalibration.	"20" is the only acceptable value; this trim can only be performed at 20 mA.

APPENDIX Serial Commands

Demand Characterizer Commands

Command	Description	Argument <i>n</i> and Information
charclear <i>n</i>	Clears a preconfigured Demand characterizer curve node by setting it to "unused". Any node numerically higher will be set to "unused" also.	<i>n</i> = node number: between 1 and 21.
charlist <i>n</i>	Displays the X-values and Y-values of Demand characterizer curve node(s).	<i>n</i> = node number: between 1 and 21. <i>n</i> = "all": displays all nodes
charset <i>n1, n2, n3</i>	Sets the X-values and Y-values of a specific node of the characterizer curve. The three arguments must be separated by commas.	<i>n1, n2, n3</i> = (<i>n1</i> is node number to modify, <i>n2</i> is X-value as a percentage, <i>n3</i> is Y-value as a percentage)
demfunc <i>n</i>	Sets/displays the Demand signal characterization function.	<i>n</i> = "0": linear <i>n</i> = "1": square root <i>n</i> = "4": special curve <i>n</i> = "5": square

Feedback Signal Commands

Command	Description	Argument <i>n</i> and Information
fdbk0pctma <i>n</i>	Sets/displays the mA value of the Feedback signal that represents the 0% output shaft position. May also be set for decreasing direction of Feedback. See page 28.	<i>n</i> = desired Feedback signal in mA at 0% output shaft position. Minimum value is 3.00 mA and the maximum must be at least 4.00 mA less than the Feedback signal value for the 100% output shaft position.
fdbk100pctma <i>n</i>	Sets/displays the mA value of the Feedback signal that represents the 100% output shaft position. May also be set for decreasing direction of Feedback. See page 28.	<i>n</i> = desired Feedback signal in mA at 100% output shaft position. Minimum value must be at least 4.00 mA greater than the Feedback signal value for the 0% output shaft position. Maximum value is 21.00 mA.
fdbkfunc <i>n</i>	Sets/displays the curve used to calculate the Feedback signal.	<i>n</i> = "0": linear <i>n</i> = "1": inverse Demand (curve enabled)
trimfdbk4mA <i>n</i>	Trims the Feedback signal at 4 mA. Calibrated at the factory, should not normally require calibration.	<i>n</i> = present Feedback signal from the DCM-3 in mA.
trimfdbk20mA <i>n</i>	Trims the Feedback signal at 20 mA. Calibrated at the factory, should not normally require calibration.	<i>n</i> = present Feedback signal from the DCM-3 in mA.
iomode <i>n</i>	Sets/displays the function of a DCM-3 connector pin. May be enabled for Feedback or potentiometer.	<i>n</i> = "0": none <i>n</i> = "1": Feedback enabled <i>n</i> = "2": potentiometer power enabled.

Command Error Codes

Code	Description	Information
2	Invalid selection	Displayed when an unknown command has been entered.
3	Value too big	Displayed when an entered numeric value exceeds expected parameters.
4	Value too small	Displayed when an entered numeric value is less than expected parameters.
5	Data length error	Displayed when the wrong number of arguments is entered.
6	General error	Displayed when a combination of circumstances prevents a better description of the error.
9	Process too high	Displayed when the entered value exceeds acceptable parameters when calibrating a 0% value.
10	Process too low	Displayed when the entered value is less than acceptable parameters when calibrating a 100% value.
14	Span too small	Displayed when entered values for a 0% point and a 100% point are too close.
32	Busy	Displayed when a memory store is requested and another memory store is already in process.
64	Not implemented	Displayed when an entered command is defined, but cannot be implemented.

APPENDIX *Optional DCM-3 w/ Feedback Display*

The DCM-3 Feedback display is an illuminated, numerical readout showing the actuator's position as a percentage of full travel. This display is viewed through a tempered glass window in the electronics compartment. There are also two configurable LEDs visible—a red LED and a green LED.

The DCM-3 display has been calibrated at the factory and should not require any further adjustments.

The display is powered from the Feedback loop current and will not operate until the loop is closed. The Feedback output maximum loop resistance is 500Ω.

The configuration for the Feedback display is 4 mA = 00.0(%) and 20 mA = 100.0(%). By default, the green LED will light when the Feedback is indicated at less than 1(%). The red LED will light when the Feedback is indicated at greater than 99(%).

The illumination points for the LEDs may be modified using a serial command (see next page).

For information on serial communication and commands, see page 53.

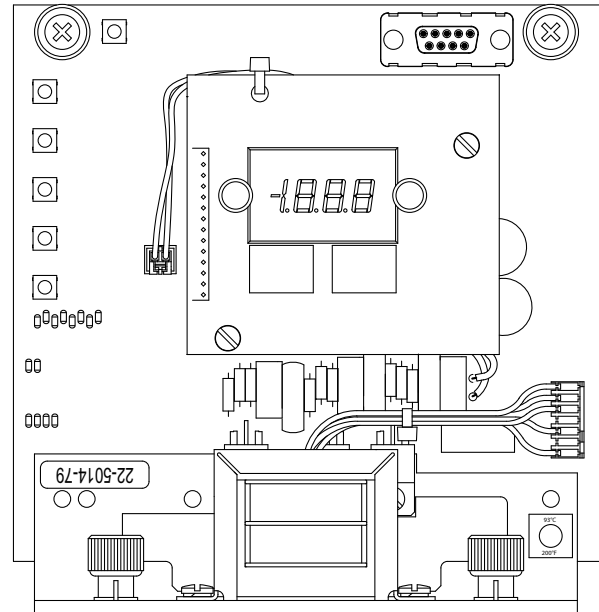

DCM-3 with Feedback Display
Part No. 22-5014-79



ledconfig <i>n1 n2</i>	Changes the point within the position of travel that causes the LEDs to light. May also be used to swap the LED end point assignments (see Example 2, below) or to individually turn off each LED.	<p><i>n1</i> = "red": sets the red LED to the <i>n2</i> argument.</p> <p>"green": sets the green LED to the <i>n2</i> argument.</p> <p>"inverted": swaps the LED end point assignments (see Example 2, below).</p> <p>"noninverted": sets both LED end points to the default setting (see below).</p> <p><i>n2</i> = argument defining position of travel at which the selected LED (<i>n1</i>) will light. Accepts any number representing a valid percentage of travel position.</p> <p>"off": turns off the LED defined in <i>n1</i>.</p>
------------------------	--	--

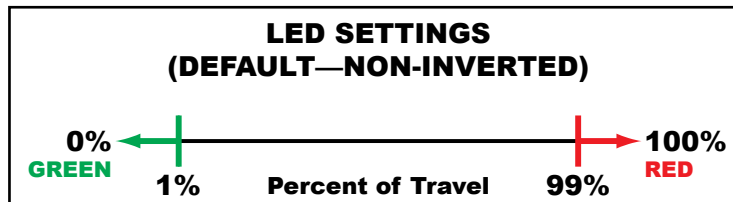

Example 1: Make the "CLOSED" green LED light at 2.0% and the "OPEN" red LED light at 98.0%.

COMMAND	RESULTING LED BEHAVIOR
ledconfig <i>green 2</i> ledconfig <i>red 98</i>	

Example 2: Invert the LED assignments from the default configuration.

COMMAND	RESULTING LED BEHAVIOR
ledconfig <i>inverted</i>	

Example 3: Make the "OPEN" red LED light at 1.0% and greater, and the "CLOSED" green LED light at less than 1.0%.

COMMAND	RESULTING LED BEHAVIOR
ledconfig <i>green 1</i> ledconfig <i>red 1</i>	

NOTE: Both LEDs will not light at the same time; in the event of overlap, the red LED will light.

APPENDIX *Optional Water Ingress Protection*

Bellows water ingress protection kits are designed for applications where the G42 actuator is mounted outdoors with the front clevis oriented skyward (see example photo at right). The kit provides protection of the shaft seal and helps prevent water ingress over time.

The weight of each kit is less than one pound, so the effect on the overall weight of the actuator is negligible.



42-109 oriented skyward on an inlet guide vane blower

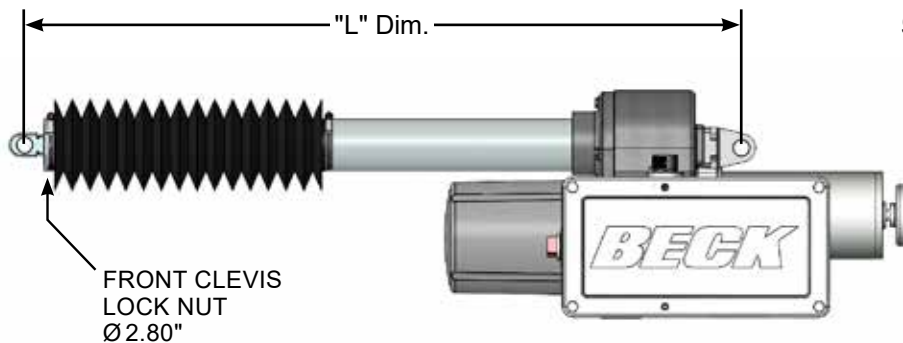

42-109 with a bellows water ingress protection kit installed

BELLOWS WATER INGRESS PROTECTION KITS

Kit No.	Clevis Hole Diameter (front/rear) (in) [mm]	Maximum Actuator Travel (in) [mm]	Minimum Actuator Travel (in) [mm]	Maximum Bellows Extension (in) [mm]	"L" Dim. Fully Retracted (in) [mm] ^{1,2}	"L" Dim. Fully Extended (in) [mm] ^{1,2}
20-3117-76	3/4 [19]	8 [203]	5 [127]	11 [279]	18 31/32 [482]	26 31/32 [685]
20-3117-77	3/4 [19]	12 [305]	7 [178]	22 1/2 [572]	22 31/32 [583]	34 31/32 [888]
20-3117-77	3/4 [19]	18 [457]	11 [279]	22 1/2 [572]	28 31/32 [736]	46 31/32 [1 193]
20-3117-78	1/2 [13]	8 [203]	5 [127]	11 [279]	18 31/32 [482]	26 31/32 [685]
20-3117-79	1/2 [13]	12 [305]	7 [178]	22 1/2 [572]	22 31/32 [583]	34 31/32 [888]
20-3117-79	1/2 [13]	18 [457]	11 [279]	22 1/2 [572]	28 31/32 [736]	46 31/32 [1 193]
20-3117-80	7/8 [22]	8 [203]	5 [127]	11 [279]	18 31/32 [482]	26 31/32 [685]
20-3117-81	7/8 [22]	12 [305]	7 [178]	22 1/2 [572]	22 31/32 [583]	34 31/32 [888]
20-3117-81	7/8 [22]	18 [457]	11 [279]	22 1/2 [572]	28 31/32 [736]	46 31/32 [1 193]

¹ When the bellows kit has been installed, the adjustment of the front clevis position is limited to +/- 1/4" from the values listed for dimension "L".

² In the event that the original "L" dimensions (prior to kit installation) are critical, modified rear clevis attachments are available to preserve the original mounting distance.

NOTES

INDEX

Appendices	43–63	Limit Switches (Over-travel)	12, 18–19, 34
HART® Communication	43–49	Loss of Demand Signal (LOS).....	24
HART® Messages	50–52	Maintenance	32–37
Serial Communication	53	Control End Assembly	36
Serial Commands	54–61	DCM-3	35
DCM-3 w/Feedback Display	62–63	Fuse (F1) w/ 3- Phase Power Options	37
Optional Water Ingress Protection.....	64	Gaskets	36
Application Reviews	67	Handswitch	35
Auxiliary Limit Switches	12, 19, 34	Motor Assembly	32
Calibration Priority	17	Motor Capacitor	32
Components	12–16	Motor Resistor Assembly.....	32
Electronic.....	13–16	Over-travel Limit & Auxiliary Switches	34
Mechanical	12	SLM	33
Configuration/Calibration	17–31	Notes	64–65
Contactless Position Sensor (CPS-4).....	13, 36	Outline Dimension Drawings	5
Demand Calibration	23	Position Calibration.....	22
Demand Characterization Curves	26–27	Position Feedback Signal	28–29
Digital Control Module (DCM-3)	13–16, 35	Power Quality	8
Interfaces.....	14	Precautionary Information	6
Maintenance	35	Product Demonstrations	67
Overview LEDs.....	15	Restore Factory Settings	21
Pushbutton Controls	16	Safety Precautions	6
Status Indication LEDs	16	Self-Locking Mechanism (SLM).....	12, 33
Direction of Output Shaft Travel	20	Serial Commands	54–61
General Operation Information	7	Serial Communication	53
General Specifications.....	4	Services.....	67
Handswitch	7, 12, 35	Site Surveys	67
Handwheel.....	7, 12	Spare Parts.....	37
HART® Communication	43–49	Specification Writing	67
HART® Device Description Menu.....	43	Split Range Operation	25
HART® Messages	50–52	Stall Protection	31
How to Obtain Service.....	63	Start-up.....	11
Installation	8–10	Step Size	21
Electrical	8–9	Storage Information.....	6
Wiring	10	Table of Contents.....	3
Introduction.....	2	Temperature Sensing	30
		Change Output Shaft Travel.....	20
		Troubleshooting	38–42
		Warranty Statement.....	67
		Wiring Diagram.....	10

SERVICES

PRODUCT DEMONSTRATIONS

Each of Beck's Sales Engineers has access to a complete set of actuator models so that he can demonstrate virtually any of their features at your location. In order to arrange to see a Beck actuator in your plant or office, contact Beck's Sales Department.

SITE SURVEYS

Beck Sales Engineers are available to discuss your process control requirements. Often a visit to your location is the best way to gain a thorough understanding of your needs, in order to meet them most accurately and completely.

Mounting hardware, thrust requirements, linkage, control signal information, and optional equipment can be analyzed most effectively at the work site. Beck's analysis at the job site can help ensure that specifications are accurate, especially in the case of complex applications.

APPLICATION REVIEWS

By sharing your needs with a Beck Sales Engineer you can take advantage of the best application advice for the type of control you

need. This review will yield a better understanding of the versatility of Beck actuators for your installations, as well as complete details on options and accessories to make the process as effective as possible.

SPECIFICATION WRITING

Beck provides specification writing assistance in order to help you specify and order the right actuators for your applications. Beck Sales Engineers will work with you to make it easier for you to obtain the proper equipment and give you confidence that no details are overlooked.

HOW TO OBTAIN SERVICE

Factory repair of actuators or subassemblies is available for both normal and emergency service. To assure prompt processing, contact the factory to receive a Returned Material Authorization (RMA) number. If a repair estimation is desired, please send the name and phone number of your contact for service authorization. It is helpful to include a description of the work desired with the shipment or, in the event of a problem, the malfunction being experienced.

THREE YEAR LIMITED EQUIPMENT WARRANTY

Beck warrants to Buyer that: (i) for a period of 3 years from the date of shipment, the Equipment manufactured by Beck shall materially conform to Beck's published standard specifications in effect as of the date of shipment; and (ii) the Beck Equipment will be free from defects in materials and workmanship. This warranty does not apply to normal wear and tear, or where Beck Equipment failure is a result of improper installation, improper storage, misuse or improper maintenance, or water ingress related to Buyer or its agents failing to apply the stated torque requirements to fasteners when attaching covers or failing to replace temporary conduit plugs as stated in the installation instructions, or entry through conduits.

During the Limited Warranty Period, Buyer shall notify Beck of any alleged warranty claim within 30 days from the date Buyer discovers, or upon reasonable inspection should have discovered, such alleged claim (but in any event prior to the end of the Limited Warranty Period), and Buyer shall return the Beck Equipment in question, at Buyer's expense, to Beck for evaluation, in compliance with the terms stated in the "Return of Equipment" article in the Sales Contract. If Beck determines that the Beck Equipment fails to conform to the limited warranty, then, at Beck's sole discretion and its expense (subject to Buyer's conformity with the warranty), Beck will either: (i) repair or replace the Beck Equipment, without charge, at Beck's factory, or (ii) refund the purchase price of such Beck Equipment, less any applicable discounts, rebates, or credits. In no event will Beck's liability exceed the contract price actually paid for such Beck Equipment subject to a warranty claim. Beck makes no warranty, express or implied, with respect to any Buyout Item. This limited warranty is not transferable or assignable to any transferees of the Beck Equipment.

THIS WARRANTY IS EXPRESSLY IN LIEU OF ANY OTHER EXPRESS OR IMPLIED WARRANTY, INCLUDING IMPLIED WARRANTIES OF MERCHANTABILITY AND FITNESS FOR A PARTICULAR PURPOSE, AND ALL OTHER OBLIGATIONS OR LIABILITIES OF BECK. BUYER ACKNOWLEDGES THAT: (i) BECK HAS MADE NO INDEPENDENT INVESTIGATION OF THE SUITABILITY OF THE EQUIPMENT FOR BUYER'S INTENDED USE OR EXISTING SYSTEMS; AND (ii) BUYER HAS NOT RELIED UPON ANY REPRESENTATION OR WARRANTY MADE BY BECK OR ANY OTHER PERSON ON BECK'S BEHALF, EXCEPT AS SPECIFICALLY PROVIDED IN THE SALES CONTRACT. THIS SECTION SETS FORTH BUYER'S SOLE AND EXCLUSIVE REMEDY FOR ANY BREACH OF THE LIMITED WARRANTY SET FORTH IN THIS SECTION.

A 100% EMPLOYEE OWNED COMPANY

BECK

- founded 1936 -

SINCE 2021



HAROLD BECK & SONS, INC.

11 TERRY DRIVE • NEWTOWN, PENNSYLVANIA 18940 • USA

PHONE: 215-968-4600 • FAX: 215-860-6383 • E-MAIL: sales@haroldbeck.com

www.haroldbeck.com

Made in USA

