

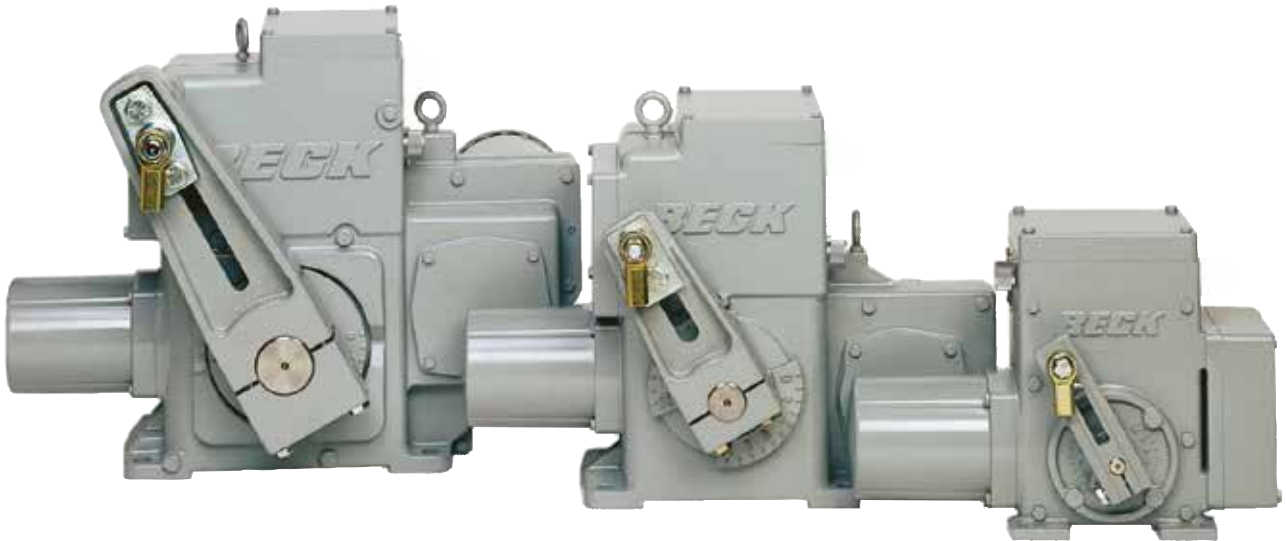

INSTRUCTION MANUAL

For actuators manufactured after March 2025.



INTRODUCTION

This manual contains the information needed to install, operate, and maintain Beck Group 11 actuators, manufactured by Harold Beck & Sons, Inc. of Newtown, Pennsylvania.

The Group 11 actuator is a powerful control package designed to provide precise position control of dampers, valves, fluid couplings and other devices requiring up to 1,800 lb-ft (2 440 N•m) of actuator torque. Exceptionally stable and trouble-free, these rotary actuators are in use throughout the world in valve and damper applications.



IMPORTANT: This manual contains information that will make installation simple, efficient, and trouble-free. Please read and understand the appropriate sections in this manual before attempting to install or operate your actuator.

This manual, along with Beck Manual Supplement 80-1100-14, is provided with applicable Group 11 & Group 11E hazardous location actuators.

TABLE OF CONTENTS

Introduction	2
General Specifications	4
Outline Dimension Drawings	6
Summary of Control Options	12
Precautionary Information	13
Component Location	14
Installation	15
Mechanical	15
Electrical	20
Wiring	21
Start-up	24
Operation	25
Calibration	27
Switches	28
Direction Change	30
Feedback Signal	32
Demand Signal	35
Maintenance	36
Routine	36
Component Replacement	37
Component Detail	45
Spare Parts & Part Numbers	48
Troubleshooting	50
Appendices	51
CPS-5 Functional Block Diagrams	51
CPS-5 Data	52
Optional LED Display	53
Index	54
Services	55

GENERAL SPECIFICATIONS

Actuator Power	120 V ac, single-phase, 60 Hz (Standard), 50 Hz (Optional) 208, 240, 380, 415, 480 & 575 V ac, 50 or 60 Hz (Optional)	Allowable Tolerance	+10% -15%					
Maximum Current (Amps) by Model*								
		Voltage (V ac)						
Model	Maximum Power (VA)	120	208	240	380	415	480	575
11-15_ / 11-16_	55	.45	.26	.23	.14	.13	.11	.09
11-20_ / 11-26_ 11-30_ / 11-36_	110	.88	.51	.44	.28	.25	.22	.18
11-40_ / 11-46_	400	3.1	1.8	1.6	.98	.89	.78	.65

*For specific motor currents, see page 54.

Operating Conditions	-40° to 85°C (-40° to 185°F) 0 to 100% relative humidity, non-condensing
Input Signal	120 V ac (low power 120 V ac or dc with optional Relay Board)
Direct AC Control	120 V ac for 2-position, multi-position or modulating V ac control
Feedback Signal with Contactless Position Sensor (CPS-5)	4–20 mA
Output Stability	0.25% of span from 102 to 132 V ac ±0.03% of span/°C for 0 to 50°C, ±0.05% of span/°C for -40° to 85°C
Linearity	±1% of span, max. independent error
Hysteresis	0.25% of span at any point
Isolation	Max. leakage of 10 µA at 60 V rms, 60 Hz from output to ground
Film Potentiometer	1,000 ohms
Max. Voltage	40 V
Wattage	2 W max.
Linearity	±0.5%
Max. Wiper Current	1 mA
Action on Loss of Power	Stays in place.
Stall Protection and Annunciation (Optional)	If the motor tries to run in one direction for more than 300 seconds, the Stall Protection Module will shut off power to the motor and a solid state relay will change state. The relay is rated for 120 V ac or dc, 10 VA.

Limit Switches	Two SPDT, one for CW and one for CCW limit of travel. Actuators having position sensing capability (Options 5 & 6), have over-travel limit switches set 1/2° outside the CW and CCW travel range; typically, -0.5° and 100.5° or 90.5°. Actuators without position sensing (Options 3 and 4), have end-of-travel limit switches set at the CW and CCW travel range; typically, 0° and 100° (or 90°).
Auxiliary Switches	Up to four 6 A, 120 V ac (0.5 A, 125 V dc) cam-operated switches (S1-S4) are available. An additional two switches may be ordered (S5-S6) with the 11-2/-3/-400 when equipped with control option 6. Factory default switch settings: S1, S4 and S5 are set to operate just before reaching the CCW travel limit. S2, S3 and S6 are set to operate just before reaching the CW travel limit. See the diagram on page 29.
Handswitch	Permits local electrical operation, independent of controller signal. Standard on all units. An auxiliary contact is available as an option for remote auto indication (rated 2.5 A at 120 V ac; 2.0 A at 28 V dc).
Handwheel	Provides manual operation without electrical power.
Motor Assembly	120 V ac, single-phase, no-burnout, non-coasting motor has instant magnetic braking. Requires no contacts or moving parts. Can remain stalled for approx. 4 days (cumulative) without damaging the gear train.
Gear Train	High-efficiency, precision-cut, heat-treated alloy steel and ductile iron spur gears. Interchangeable gear modules permit field change of torque and timing.
Mechanical Stops	Prevent overtravel during automatic or manual operation.
Enclosure	Precision-machined, aluminum alloy castings coated with corrosion-resistant polyurethane paint, provide a rugged, dust-tight, weatherproof enclosure. Actuators designed for hazardous classified locations are also available. Type 4X; IP66/IP68, 3 meters/48 hours*. *Internal water damage is not covered by warranty.
Maximum Output Shaft Rotation	100 degrees (Models 11-15_, 11-20_, 11-30_, 11-40_) 90 degrees (Models 11-16_, 11-26_, 11-36_, 11-46_)
Mounting Orientation	Any orientation—no limitations.
Standards**	CSA Labeled (US & Canada); CE Compliant; UKCA Compliant
**NOTE: May not be available with all options and models. For more information, please call Beck at 215-968-4600.	

OUTLINE DIMENSION DRAWINGS

MODEL 11-15_ SPECIFICATIONS

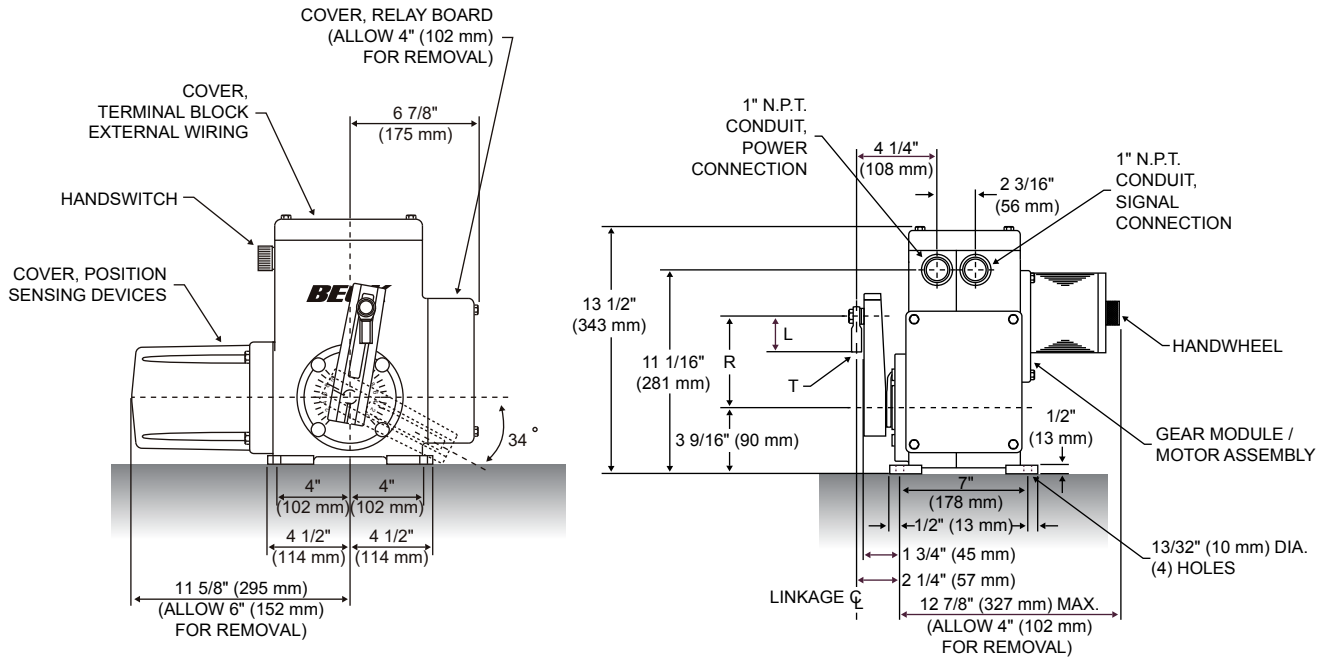

Crank Arm

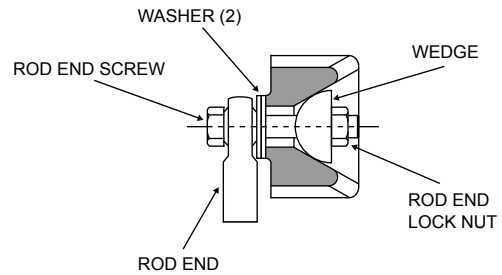
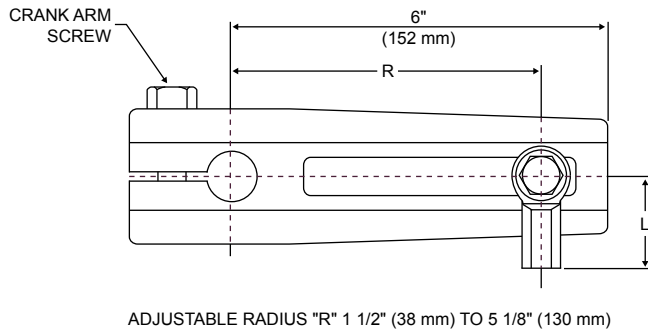

Model 11-15_ Crank Arm Part Numbers & Model Information

Crank Arm Assembly	10-3491-05
Crank Arm	10-3491-02
Crank Arm Screw (1)	30-0306-56
Washer (2)	30-0313-03
Wedge	11-8060-02
Rod End Screw	30-0306-56
Rod End Lock Nut	30-0309-11
Rod End	12-2840-02
Dim. "L" (Length)	2 1/8" (54 mm)
Dim. "T" (Thread)	1/2-20 x 1-3/16" (30 mm)
Output Shaft Diameter	3/4" (19 mm)
Approximate Weight	50 lbs (23 kgs)
Max. Overhung Load	750 lbs (340 kgs)

Recommended Screw Torques

	Screw Size (in.)	Wrench Size (in.)	Torque	
			lb-ft	N•m
Crank Arm Screw	1/2-13	3/4	75	102
Rod End Screw	1/2-13	3/4	35*	47*
Rod End Lock Nut	1/2-13	3/4	35*	47*
Body Screw	5/16-18	1/2	10	14
Body Screw	3/8-16	9/16	20	27
Cover Screw	5/16-18	1/2	10	14
Motor / Gear Module Screw	1/4-20	7/16	6	8

*Apply 90% of specified torque when optional Stainless Steel fasteners are used.

MODEL 11-16_ SPECIFICATIONS

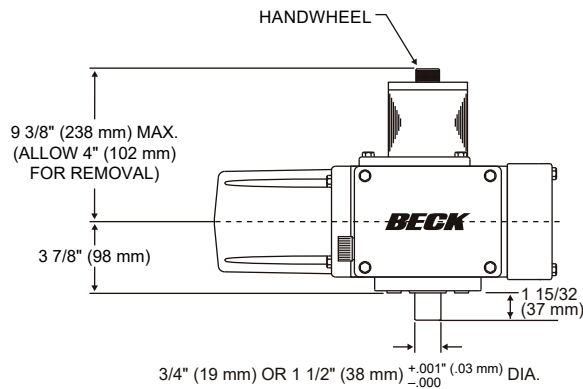
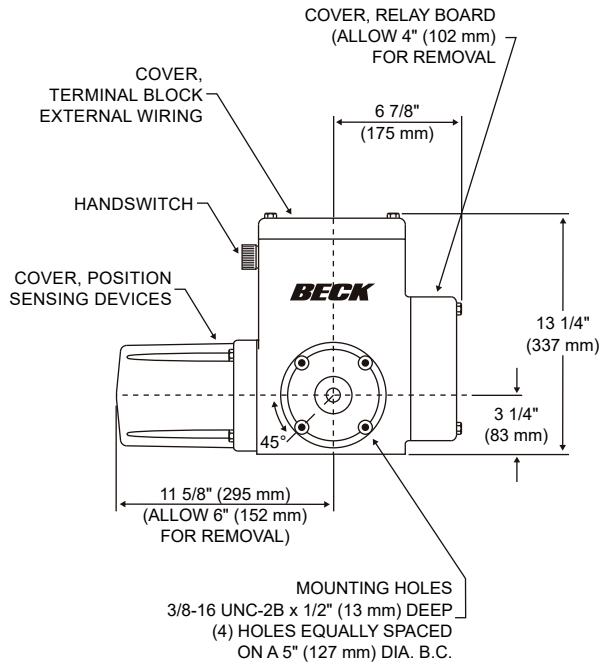

TYPICAL VALVE MOUNTING

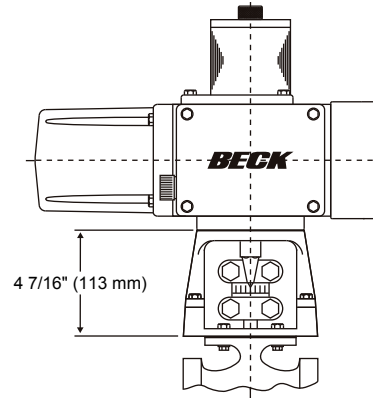
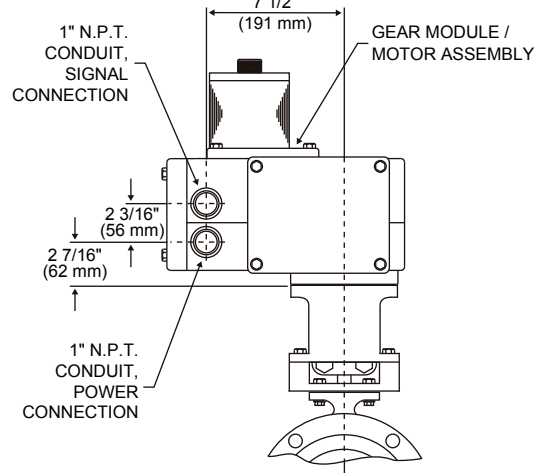

Recommended Screw Torques

Model Information

Approximate Weight	56 lbs. (25 kg)
Maximum Overhung Load	750 lbs. (340 kg)

	Screw Size (in.)	Wrench Size (in.)	Torque	
			lb-ft	N•m
Coupling Screw	-	--	*	*
Mounting Bracket Screw (Flat Head)	3/8-16	-	25	34
Body Screw	5/16-18	1/2	10	14
Body Screw	3/8-16	9/16	20	27
Cover Screw	5/16-18	1/2	10	14
Motor / Gear Module Screw	1/4-20	7/16	6	8

*Varies per application. Refer to the valve mounting specification sheet shipped with your actuator.

OUTLINE DIMENSION DRAWINGS

MODEL 11-20_ & 11-30_ SPECIFICATIONS

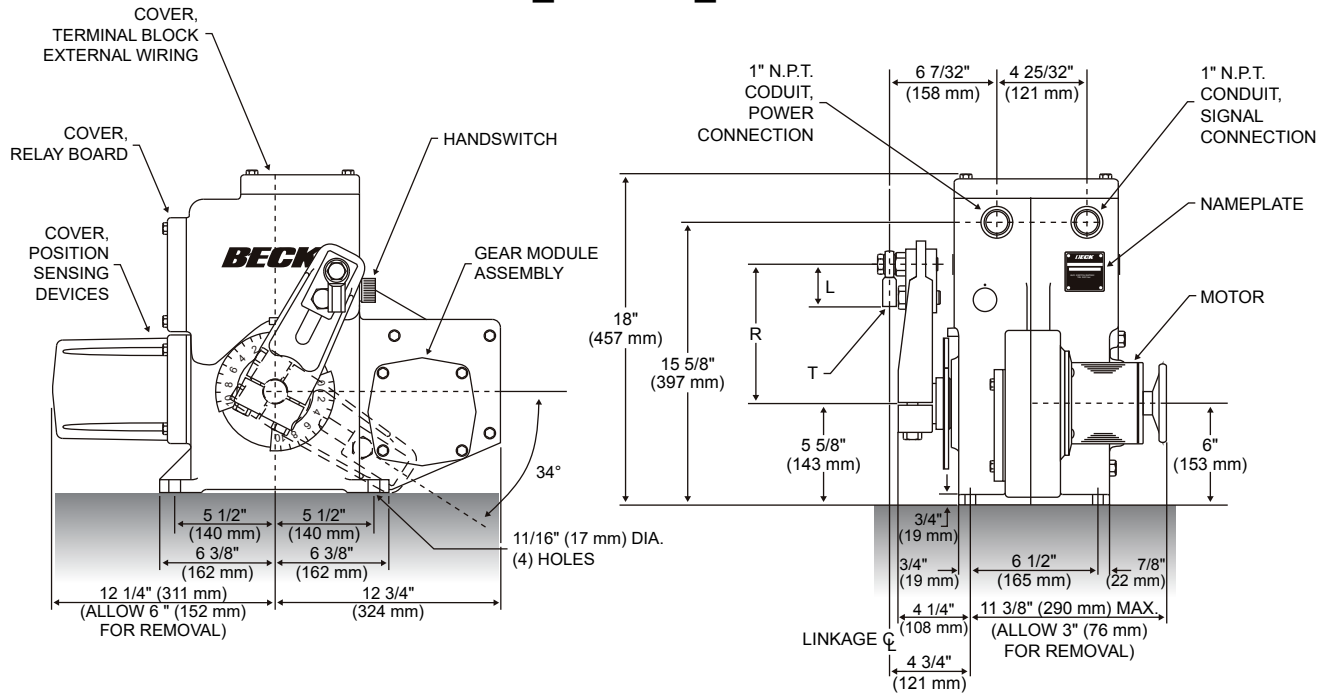

Crank Arm

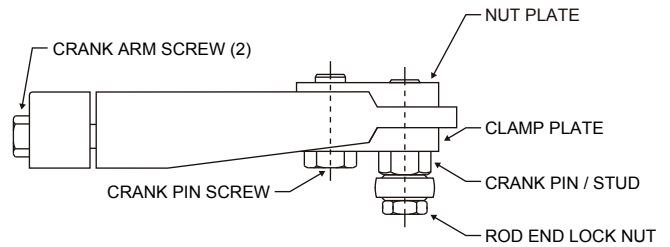
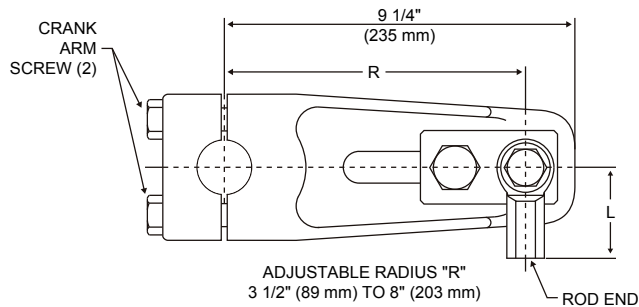

Recommended Screw Torques

	Screw Size (in.)	Wrench Size (in.)	Torque	
			lb-ft	N•m
Crank Arm Screw	5/8-18	15/16	240*	325*
Crank Pin / Stud	3/4-16	1-1/8	300*	407*
Crank Pin Screw	3/4-16	1-1/8	300*	407*
Rod End Lock Nut				
(11-20_)	1/2-20	3/4	35*	47*
(11-30_)	5/8-18	15/16	65*	88*
Body Screw	3/8-16	9/16	20	27
Body Screw	1/2-13	3/4	50	68
Cover Screw	5/16-18	1/2	10	14
Motor Screw (Hex Wrench)	1/4-20	3/16	6	8
Gear Module Screw	5/16-18	1/2	10	14

*Apply 90% of specified torque when optional Stainless Steel fasteners are used.

Model 11-20_ / 11-30_ Crank Arm Part Numbers & Model Information

	11-20_	11-30_
Crank Arm Assembly	14-7330-40	14-8010-34
Crank Arm	14-8008-05	14-8008-01
Crank Arm Screw (2)	30-0308-75	30-0308-75
Clamp Plate	14-9883-01	14-9883-01
Crank Pin / Stud	14-9920-06	14-9920-07
Crank Pin Screw	30-0308-61	30-0308-61
Nut Plate	14-9883-02	14-9883-02
Rod End Lock Nut	30-0309-19	30-0309-23
Rod End	12-2840-02	12-2840-03
Dim. "L" (Length)	2 1/8" (54 mm)	2 1/2" (64 mm)
Dim. "T" (Thread)	1/2-20 x 1-3/16" (30 mm)	5/8-18 x 1-1/2" (38 mm)
Output Shaft Diameter	1 1/2" (38 mm)	1 3/4" (44 mm)
Approximate Weight	120 lbs (54 kgs)	125 lbs (57 kgs)
Max. Overhung Load	3,000 lbs (1,361 kgs)	4,500 lbs (2,041 kgs)

MODEL 11-26_ & 11-36_ SPECIFICATIONS

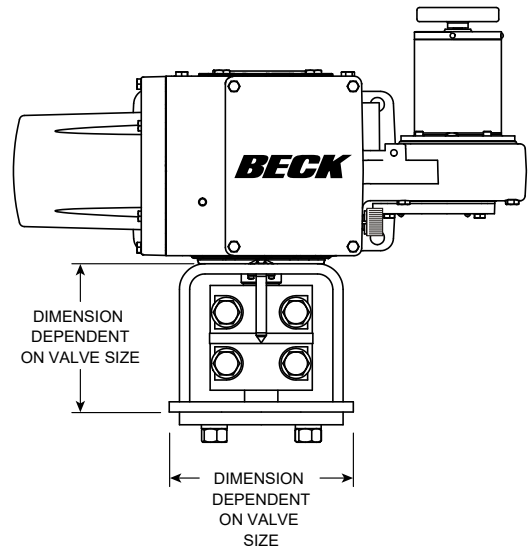
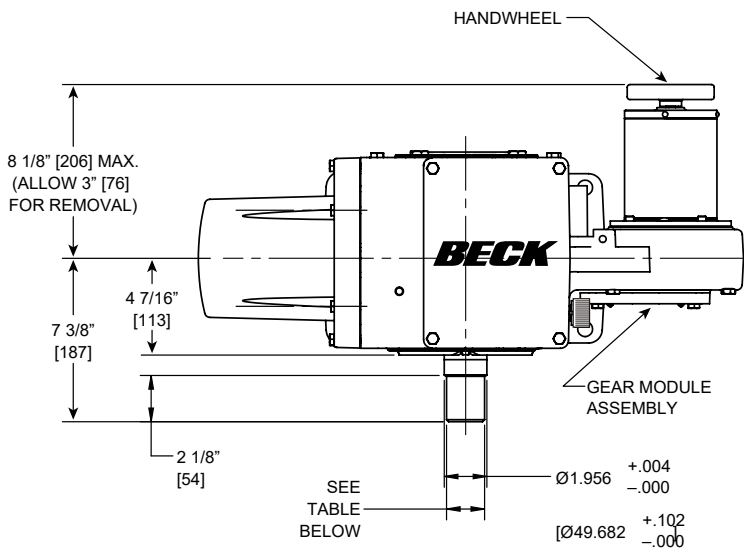
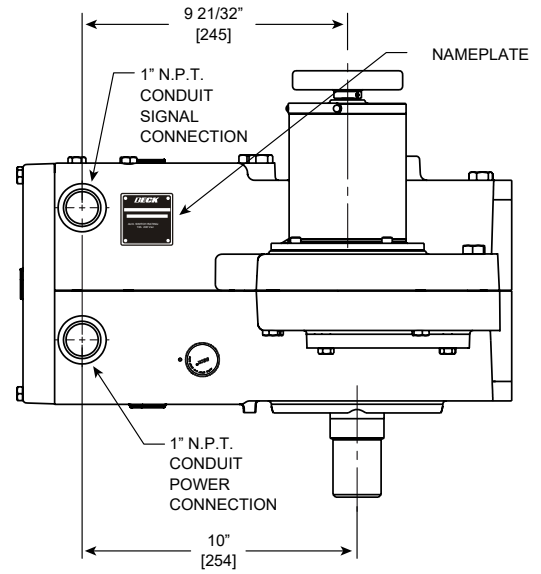
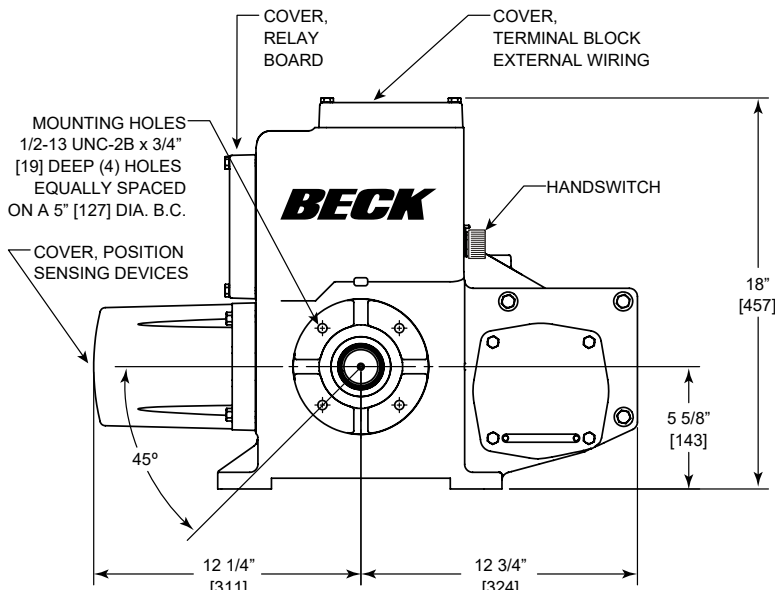

Model Information

Model No.	Torque Range	Approx. Weight	Maximum Overhung Load	Output Shaft Diameter
11-260	125–250 (lb-ft)	120 lbs.	3,000 lbs.	1.500 in. (+.001/-0.000)
	169–339 (N•m)	54 kgs.	1361 kgs.	38.100 mm. (+.025/-0.000)
11-360	300–650 (lb-ft)	120 lbs.	4,500 lbs.	1.750 in. (+.001/-0.000)
	407–881 (N•m)	54 kgs.	2041 kgs.	44.450 mm. (+.025/-0.000)

Recommended Screw Torques

	Screw Size (in.)	Wrench Size (in.)	Torque	
			lb-ft	N•m
Coupling Screw	5/8-18	15/16	*	*
Mounting Bracket Screw (Flat Head)	1/2-13	-	50	68
Body Screw	1/2-13	3/4	50	68
Body Screw	3/8-16	9/16	20	27
Cover Screw	5/16-18	1/2	10	14
Motor Screw (Hex Wrench)	1/4-20	3/16	6	8
Gear Module Screw	5/16-18	1/2	10	14

*Varies per application. Refer to the valve mounting specification sheet shipped with your actuator.

OUTLINE DIMENSION DRAWINGS

MODEL 11-40_ SPECIFICATIONS

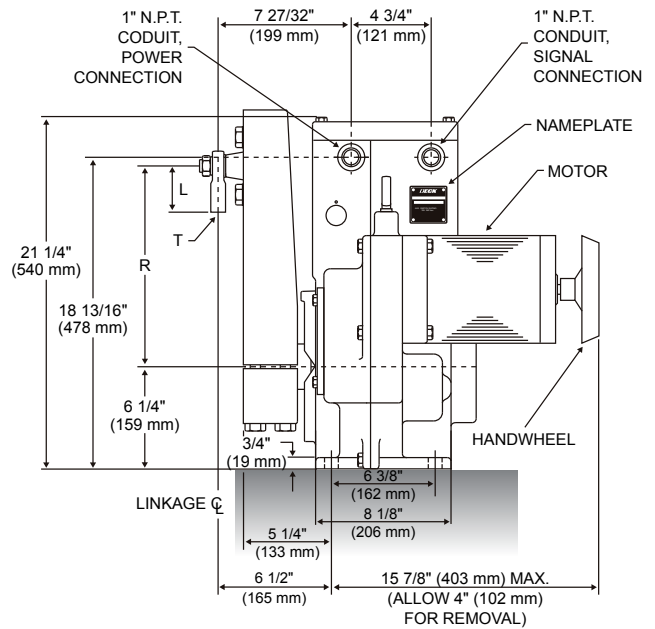
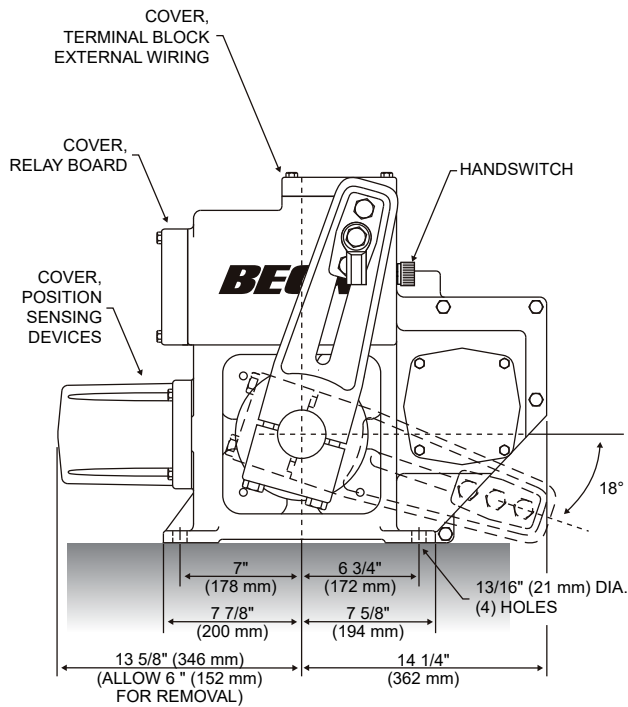

Crank Arm

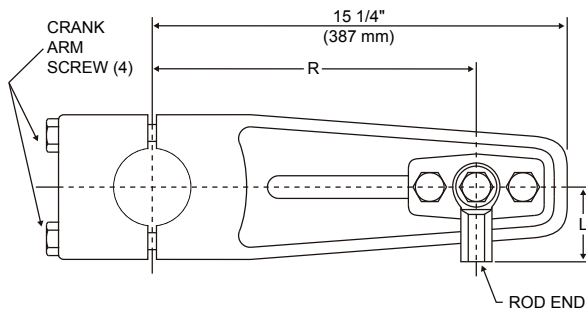

ADJUSTABLE RADIUS "R" 6" (152 mm) TO 12" (305 mm)

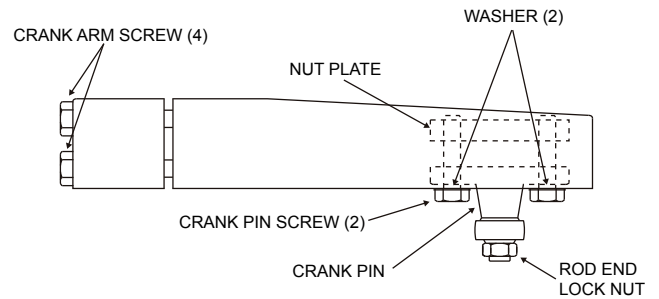

Model 11-40_ Crank Arm Part Numbers & Model Information

Recommended Screw Torques

	Screw Size (in.)	Wrench Size (in.)	Torque	
			lb-ft	N•m
Crank Arm Screw	5/8-18	15/16	170	230
Crank Pin Screw	3/4-16	1-1/8	300*	407*
Rod End Lock Nut	3/4-16	1-1/8	120*	163*
Body Screw	3/8-16	9/16	20	27
Body Screw	1/2-13	3/4	50	68
Cover Screw	5/16-18	1/2	10	14
Motor Screw	3/8-16	9/16	16	22
Gear Module Screws	5/16-18	1/2	10	14

*Apply 90% of specified torque when optional Stainless Steel fasteners are used.

	11-409
Crank Arm Assembly	14-8018-02
Crank Arm	14-8018-01
Crank Arm Screw (4)	30-0328-43
Washer (2)	30-0313-27
Crank Pin	14-9882-01
Crank Pin Nut Plate	20-2641-01
Crank Pin Screw (2)	30-0308-03
Rod End Lock Nut	30-0309-24
Rod End	12-2840-04
Dim. "L" (Length)	2 7/8" (73 mm)
Dim. "T" (Thread)	3/4-16 x 1-3/4" (44 mm)
Output Shaft Diameter	2 3/4" (70 mm)
Approximate Weight	270 lbs (122 kgs)
Max. Overhung Load	9,000 lbs (4 082 kgs)

MODEL 11-46_ SPECIFICATIONS

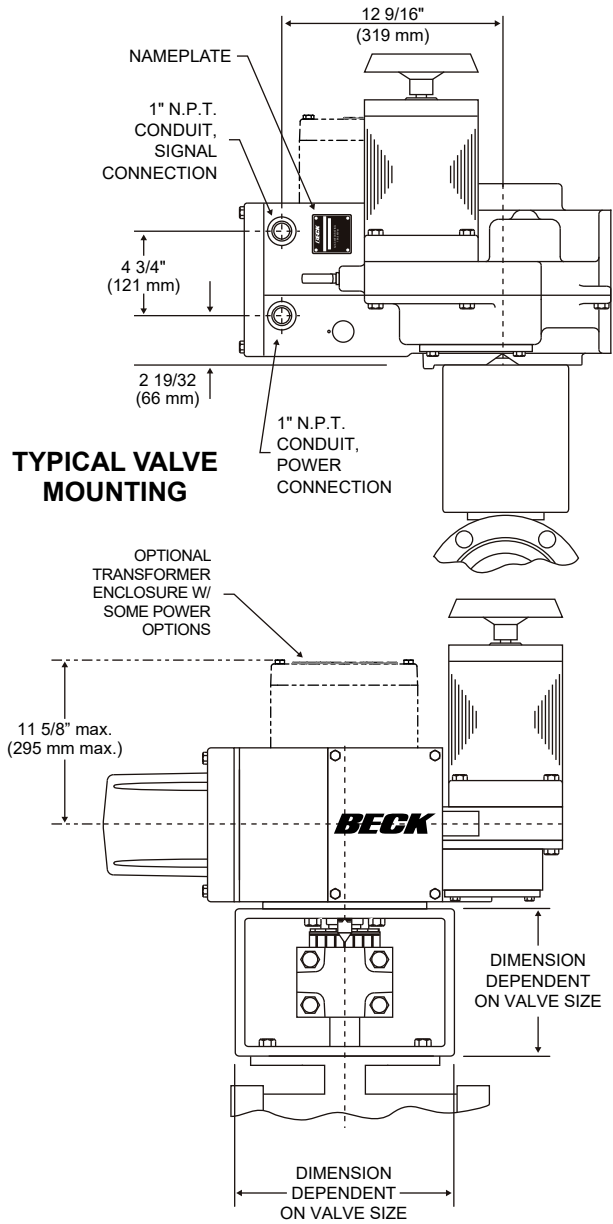
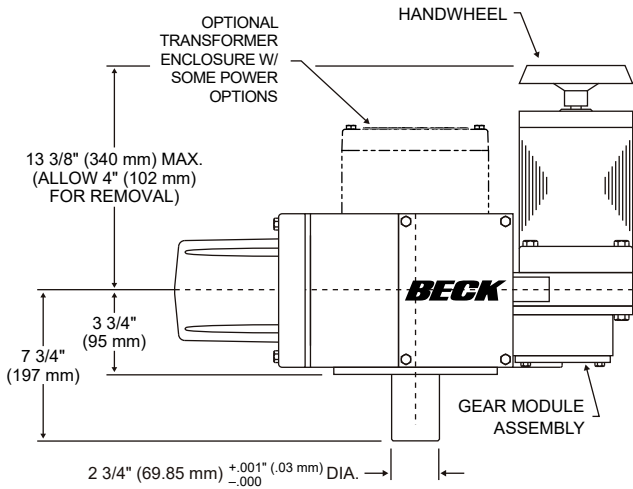
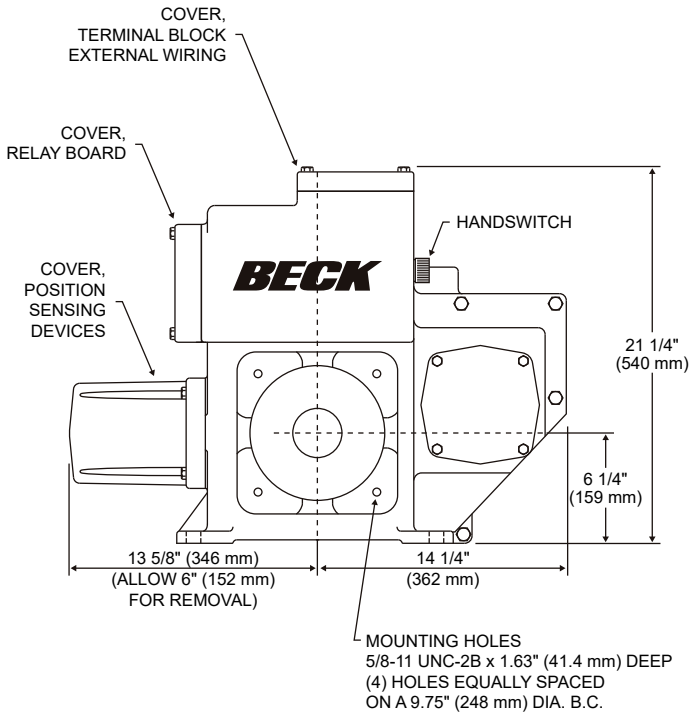

Recommended Screw Torques

Model Information

Approximate Weight	216 lbs. (98 kg)
Maximum Overhung Load	9,000 lbs. (4 082 kg)

	Screw Size (in.)	Wrench Size (in.)	Torque	
			lb-ft	N·m
Coupling Screw	-	-	*	*
Mounting Bracket Screw	5/8-11	15-16	100	135
Body Screw	1/2-13	3/4	50	68
Body Screw	3/8-16	9/16	20	27
Cover Screw	5/16-18	1/2	10	14
Motor Screw	3/8-16	9/16	16	22
Gear Module Screw	5/16-18	1/2	10	14

*Varies per application. Refer to valve mounting specification sheet shipped with your actuator.

SUMMARY OF CONTROL OPTIONS

MODEL NO.	CONTROL TYPE	INPUT SIGNAL	RELAY BOARD PART NO.	FEEDBACK DEVICE	EXTERNAL OUTPUT SIGNAL	CPS-5 PART NO.*	AUXILIARY SWITCH OPTIONS
11-__6	Direct AC Control (Modulating)	120 V ac	None	CPS-5 Contactless Position Sensor	4–20 mA	20-4400-02	None, 2, 4, 6**
		Low Power 120 V ac	13-2246-50				
		Low Power dc	13-2246-51				
11-__5	Direct AC Control (Modulating)	120 V ac	None	1000 ohm Potentiometer 20-3060-03	1000 ohm Pot.	n/a	None, 2, 4
		Low Power 120 V ac	13-2246-50				
		Low Power dc	13-2246-51				
11-__4	5 Position	120 V ac	n/a	None	None	n/a	None
	4 Position						None, 2
	3 Position						
11-__3	2 Position Open/Close	120 V ac	n/a	None	None	n/a	None, 2, 4

* CPS-5 series 20-4400-02 boards replace 20-3400-02 series boards.

** Available with 11-200, 11-300 and 11-400 actuators.

PRECAUTIONARY INFORMATION

SAFETY PRECAUTIONS



WARNING

Installation and service instructions are for use by qualified personnel only. To avoid injury and electric shock, do not perform any servicing other than that contained in this manual. Please read and understand the appropriate sections in this manual before attempting to install or operate your actuator.

STORAGE INFORMATION

Beck actuators should be stored in a clean, dry area where the temperature is between -40° and 85°C (-40° to 185°F).

Damage due to moisture while in storage is not covered by warranty.

INSTALLATION—MECHANICAL

There are many considerations regarding proper mechanical installation—see the instructions beginning on page 15 for details. Refer to the outline dimension drawings for physical dimensions and required clearances.

VALVE ACTUATOR INSTALLATIONS



CAUTION

Working with valves installed in a pipeline can be dangerous. Take appropriate precautions when mounting to installed valves.

INSTALLATION—ELECTRICAL

See the instructions beginning on page 18 for details regarding electrical installation.



CAUTION

For maximum safety, the Beck actuator body should be grounded. Use the green grounding screw in the wiring compartment of the actuator.



CAUTION

Always close covers immediately after installation or service to prevent moisture or other foreign matter from entering the actuator.

CONDUIT ENTRIES

Conduit entries are provided for power and signal wiring. Temporary plugs are installed in the conduit entrances at the factory for shipping only and are not intended for permanent use. Prior to actuator operation, all conduit entrances must be properly sealed in accordance with National Standards or Regulatory Authorities.

COMPONENT LOCATION

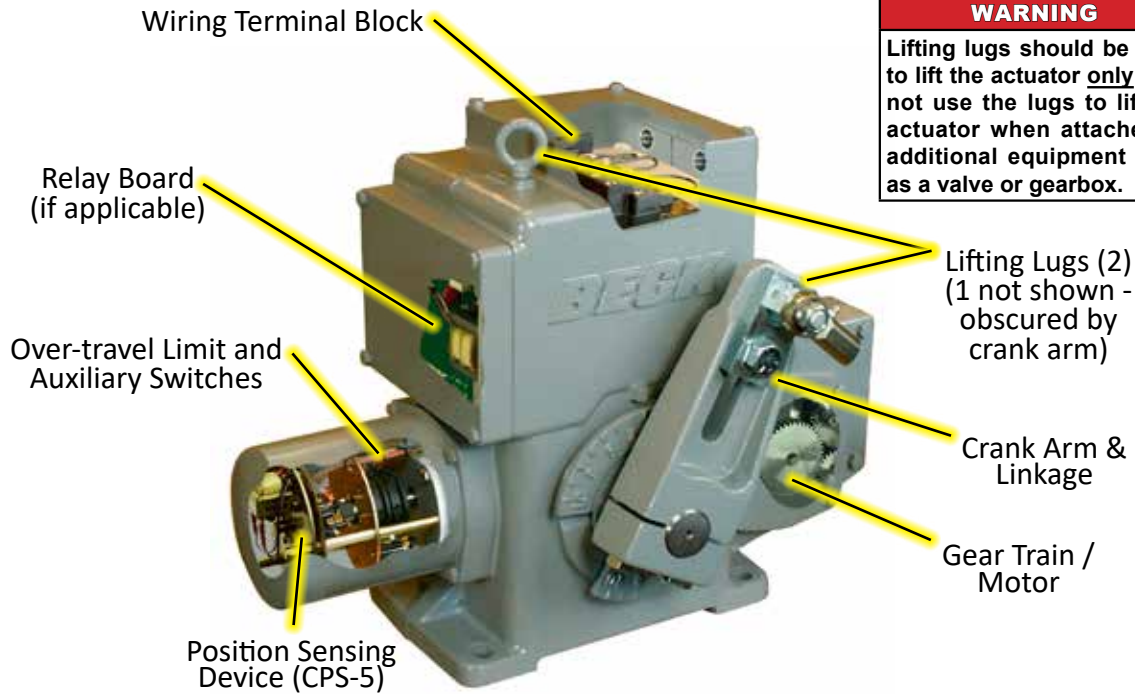

WARNING
 Lifting lugs should be used to lift the actuator only -- do not use the lugs to lift the actuator when attached to additional equipment such as a valve or gearbox.

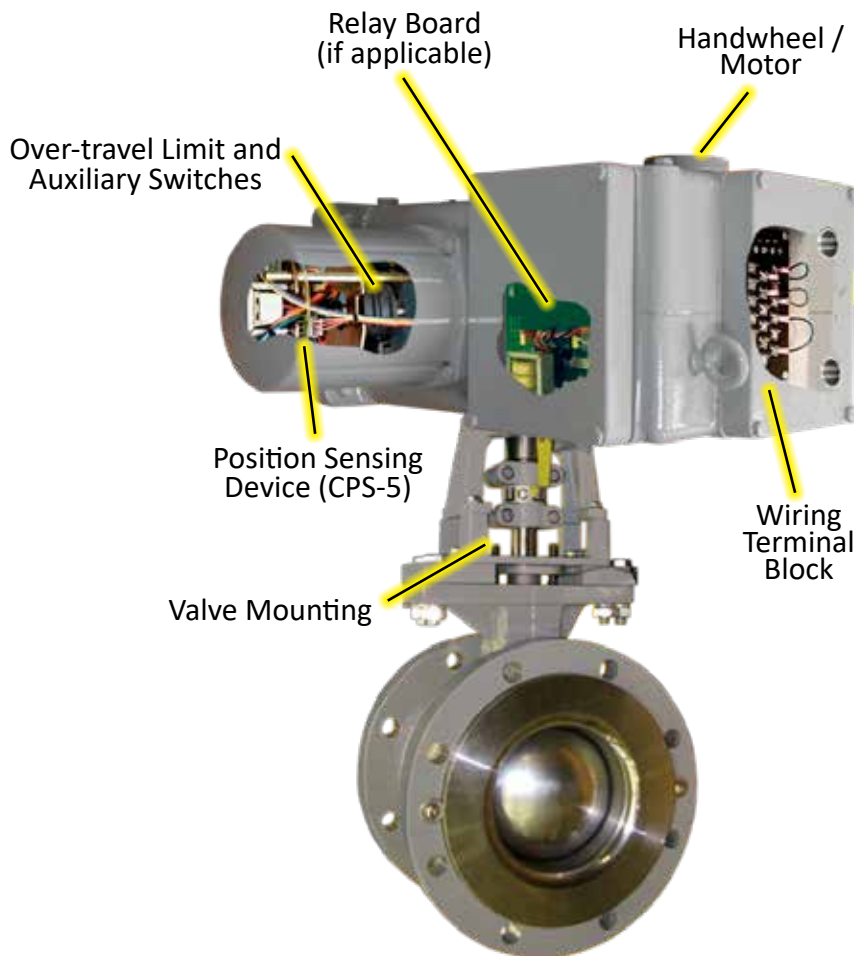

MODEL GROUP 11 COMPONENTS

INSTALLATION Mechanical

INSTALLATION—MECHANICAL

Beck Group 11 actuators may be installed in any convenient orientation, because the gearing does not require an oil bath. Refer to the outline dimension drawings for physical dimensions and required clearances.

VALVE ACTUATOR INSTALLATIONS



CAUTION

Working with valves installed in a pipeline can be dangerous. Take appropriate precautions when mounting to installed valves.

Whenever an actuator is being mounted on a valve, refer to the valve manufacturer's maintenance manual for specific valve-related instructions. Consult the Beck Valve Mounting Specification sheet shipped with the actuator for specific instructions on assembly of the Beck actuator and mounting hardware to the valve. It is good practice to remove the valve from service if possible.

UNITIZED VALVE/ACTUATOR ASSEMBLY INSTALLATION

Inspect the valve and pipe flanges to ensure they are clean. Be certain that other pipelines in the area are free from pipe scale or welding slag that could damage the gasket surfaces.

Carefully lift the assembly and position the valve in the pipeline. Install and tighten the flange bolts according to the valve and/or gasket manufacturer's instructions.

NOTE: The valve may have undergone temperature variations in shipment. This could result in seepage past the stem seals. Refer to the valve manufacturer's maintenance instructions for packing adjustments, if required.

FOOT MOUNTED ACTUATOR INSTALLATIONS

Actuators may be mounted in any orientation. If mounting near obstructions such as pipes or beams, take into consideration access to the field wiring terminals, enclosure cover clearances, and the output shaft. Refer to the outline dimension drawings for the clearance necessary to remove covers.

Before the actuator is bolted into place, the mounting surface must be shimmed for flatness to within 0.020 inches. Each shim must support at least 75% of the mounting foot surface area (recommended shim size is 4 square inches or larger). Improper shimming or mounting can damage the actuator mounting feet.

If the actuator is to be bolted to a mounting plate, the plate must be rigid and must not yield to the stresses created from operating the actuator. If the mounting plate is not rigid or the mounting bolts are not sufficiently tightened, damage to the actuator housing could result. A rigid, vibration-free surface will generally prolong the life of the actuator's components. The mounting plate should be at least as thick as the diameter of the mounting bolts.

Mounting bolts should be hex head steel, zinc plated (HHSZP) Grade 2 or better and sized as shown in the table below. The bolts should be torqued appropriately for the application.

Actuator Model	Bolt Size	Bolt Torque
11-15_	3/8"	20 lb-ft (27 N•m)
11-20_ / 11-30_	5/8"	100 lb-ft (135 N•m)
11-40_	3/4"	175 lb-ft (237 N•m)

MOUNTING PEDESTALS

Standard and custom retrofit Beck pedestals are available, including designs for a number of common pneumatic actuators such as the Bailey AC and UP series and Hagan cylinders. A typical generic pedestal is shown here.



INSTALLATION Mechanical

LINKAGE REQUIREMENTS

(IF APPLICABLE)

For best results, the linkage should be designed in advance. In most applications, the best control will result when the linkage is adjusted so that the full 100° travel of the Beck actuator shaft is used, even though the driven lever may travel less than 100°. The general requirements for a good linkage are:

1. It must be rigid enough to carry the link thrust without bending or deforming.
2. It must have a built-in means of adjustment so that the length of the connecting link can be changed a small amount.
3. Rod end bearings, similar to those furnished on the Beck crank arm, should be used at both ends of the connecting link. This type of device permits small angular misalignments and helps prevent binding of the linkage.
4. The Beck crank arm radius must be calculated so that the arm will move through a 100° arc and the driven lever will move through its correct arc.
5. The actuator and driven shafts must be parallel and the linkage should be in a plane perpendicular to the shafts. See the example of a parallel linkage arrangement at right. Z-Linkage arrangements (where linkage ends are on opposite sides of the parallel between the driven shaft and actuator output shaft) are **not** recommended.

LINK-ASSIST™ REPORT

The Beck Link-Assist™ computer program optimizes the linkage configuration for the application load. It ensures proper setup and operation of the actuator. Contact your Beck Sales Engineer to take advantage of Beck's Link-Assist™ program. Additional Link-Assist™ information is available on the Beck website: www.haroldbeck.com.

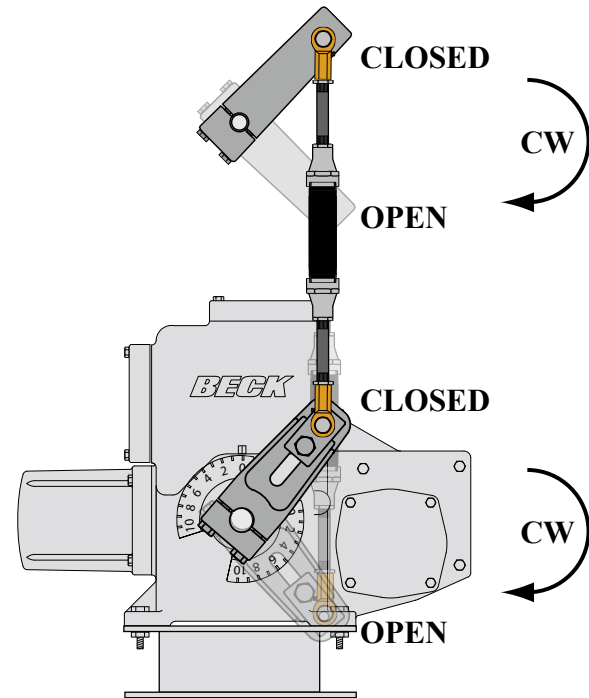

**Parallel Linkage
Design Example
(Recommended)**

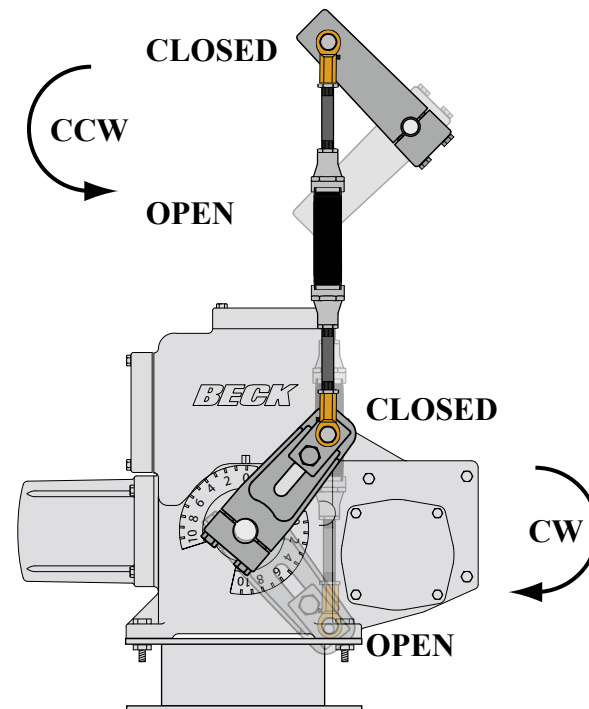

**Z-Linkage
Design Example
(Not Recommended)**

LINKAGE KITS AVAILABLE

Beck linkage kits are made to accommodate a wide variation in linkage lengths without requiring modification of end fittings. Linkage kits are also available in stainless steel for use in corrosive environments.

Hex Linkage kits are available for applications with linkage length requirements between 9" (229 mm) and 33" (838 mm). Each hex linkage kit comes complete with a rod end, studs, threaded hex bar, and jam nut hardware.

To order hex linkage kits, first obtain the approximate overall linkage length "A" in the hex linkage figure on page 18. Select the kit part number from the corresponding table. For lengths beyond those listed in the table, contact your Beck sales engineer.

Pipe linkage kits are available for longer linkage length requirements and include the essential linkage end connections, rod end, studs, and jam nut hardware. Schedule 40 pipe is not included and must be cut to length and threaded in the field (see the table on page 18 for instructions to calculate pipe length). To simplify installation of the pipe link, the kit accepts NPT right-hand threads on both ends of the pipe. Left-hand threads are internal to the linkage kit assembly, making final length adjustments quick and easy.

To order pipe linkage kits, first obtain the approximate overall linkage length "A" in the figure on page 18. Select the kit part number from the corresponding table. For lengths beyond those listed in the table, contact your Beck sales engineer.



Pipe Linkage



**Hex Linkage
(Stainless Steel Option)**

INSTALLATION Mechanical

PIPE LINKAGE KITS

Beck Actuator Model No.	Linkage Length	Linkage Kit Part No.	Stainless Steel Linkage Kit Part No.	Pipe Size	Rod End Thread	Length of 2 Linkage Ends (+/- 1.5" (38 mm))
11-15_	22-84" (559-2 134 mm)	20-1730-05	20-1730-15	1" (25 mm)	1/2-20 UNF	20 1/2" (521 mm)
	31-120" (787-3 048 mm)	20-1740-06	20-1740-16	1.5" (38 mm)		29 1/4" (743 mm)
11-20_	22-45" (559-1 143 mm)	20-1730-05	20-1730-15	1" (25 mm)	1/2-20 UNF	20 1/2" (521 mm)
	31-84" (787-2 134 mm)	20-1740-06	20-1740-16	1.5" (38 mm)		29 1/4" (743 mm)
	33 1/4-120" (845-3 048 mm)	20-1750-05	20-1750-15	2" (51 mm)		31 1/4" (794 mm)
	37-120" (940-3 048 mm)	20-1760-05	20-1760-16	2.5" (64 mm)		34 1/2" (876 mm)
11-30_	22 1/2-36" (572-914 mm)	20-1730-06	20-1730-16	1" (25 mm)	5/8-18 UNF	21" (533 mm)
	31 1/2-72" (800-1 829 mm)	20-1740-07	20-1740-17	1.5" (38 mm)		29 3/4" (756 mm)
	33 3/4-96" (857-1 219 mm)	20-1750-06	20-1750-16	2" (51 mm)		31 3/4" (806 mm)
	37 1/2-120" (953-3 048 mm)	20-1760-06	20-1760-16	2.5" (64 mm)		35" (889 mm)
11-40_	23 1/4-34" (590-864 mm)	20-1730-07	20-1730-17	1" (25 mm)	3/4-16 UNF	21 3/4" (552 mm)
	32 1/4-48" (819-1 219 mm)	20-1740-08	20-1740-18	1.5" (38 mm)		30 1/2" (775 mm)
	34 1/2-72" (876-1 829 mm)	20-1750-07	20-1750-17	2" (51 mm)		32 1/2" (826 mm)
	38 1/4-120" (972-3 048 mm)	20-1760-07	20-1760-17	2.5" (64 mm)		35 3/4" (908 mm)

*NOTE: To calculate length of pipe required, subtract "Length of 2 Linkage Ends" (shown in table above) from Linkage Length "A" (shown in diagram below).

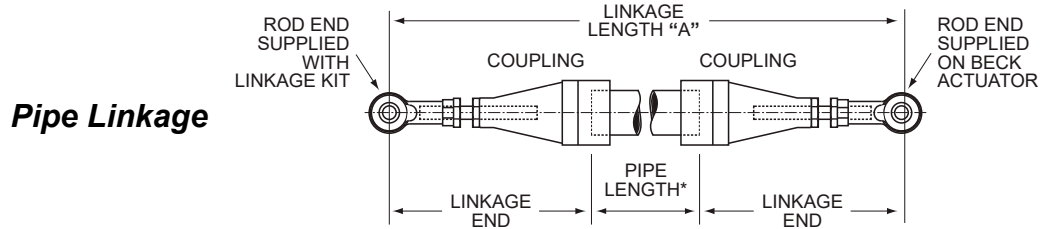

HEX LINKAGE KITS

Beck Actuator Model No.	Linkage Length	Linkage Kit Part No.	Stainless Steel Linkage Kit Part No.	Hex Size	Rod End Thread
11-15_	9-11.5" (229-292 mm)	14-8300-22	14-8300-64	5/8" [15.88]	1/2-20 UNF
	10.5-14.5" (269-371 mm)	14-8300-32	14-8300-72		
	14.5-18.5" (368-470 mm)	14-8300-04	14-8300-48		
	18-22" (457-559 mm)	14-8300-06	14-8300-50		
	22-26" (559-660 mm)	14-8300-16	14-8300-58		
11-20_	9-11.5" (229-292 mm)	14-8300-22	14-8300-64	5/8" [15.88]	1/2-20 UNF
	10.5-14.5" (269-371 mm)	14-8300-32	14-8300-72		
	14.5-18.5" (368-470 mm)	14-8300-04	14-8300-48		
	18-22" (457-559 mm)	14-8300-06	14-8300-50		
	22-26" (559-660 mm)	14-8300-16	14-8300-58		
11-30_	13.5-18" (343-457 mm)	14-8860-24	14-8860-62	1" [25.40]	5/8-18 UNF
	17.5-22" (445-559 mm)	14-8860-08	14-8860-48		
	22-26.5" (559-673 mm)	14-8860-02	14-8860-42		
	26.5-31" (673-787 mm)	14-8860-04	14-8860-44		
11-40_	13.5-17.5" (343-445 mm)	15-0110-26	15-0110-68	1" [25.40]	3/4-16 UNF
	18-22" (457-559 mm)	15-0110-20	15-0110-62		
	22-26" (559-660 mm)	15-0110-03	15-0110-46		
	26-30" (660-762 mm)	15-0110-22	15-0110-64		
	29-33" (737-838 mm)	15-0110-02	15-0110-44		

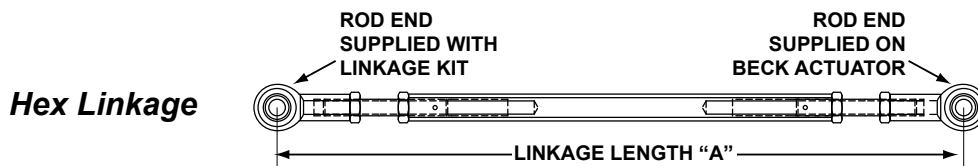

LINKAGE INSTALLATION

The following procedure is recommended to couple the linkage between the Group 11 actuator and the driven shaft:

1. Position the driven shaft ① to the fully closed position.
2. Set the driven shaft lever to its required starting angle ② (predetermined with Link-Assist™).
3. Remove the rod end ③ from the Beck crank arm. Attach to the connecting link.
4. Adjust the connecting link ④ to the predetermined length.
5. Connect the connecting link to the driven lever at the predetermined radius ⑤.
6. Set the crank pin ⑥ (or rod end screw on 11-15_, see appropriate outline dimension drawing) on the Beck crank arm to the predetermined radius. This is done by loosening the crank pin screws ⑦ and sliding the crank pin to the predetermined position (none on 11-15_). Tighten the crank pin screws to the appropriate torque.
7. Loosen the crank arm clamping screws ⑧.



CAUTION

The crank arm will pop free, allowing adjustment for 360° around the shaft.

8. Position the actuator's output shaft ⑨ to its fully closed limit.
9. Swing the crank arm into position and assemble the connecting link to the crank arm crank pin. Tighten the rod end nut ⑥ to the appropriate torque (see table next page).
10. Tighten the crank arm screws ⑧ evenly, in a cross-pattern (if applicable), to the appropriate torque (see outline dimension tables beginning on page 6).
11. Lubricate the rod end bearings.

Carefully move the actuator's output shaft to the fully open (maximum Demand signal) position. Check that no binding occurs between the linkage, crank arm, driven shaft lever, and surrounding obstructions. Also observe that the driven shaft rotates the proper amount. Ensure that the actuator reaches the proper limit and shuts off.

If binding in the linkage occurs due to too much travel of the driven lever, travel can be reduced by shortening the Beck actuator crank arm radius. Return the actuator to the fully closed position. Loosen the crank arm crank pin screws, and the linkage stud-coupling lock nuts. To make fine length adjustments, while rotating the linkage move the crank pin to a shorter radius position.

LINKAGE INSTALLATION

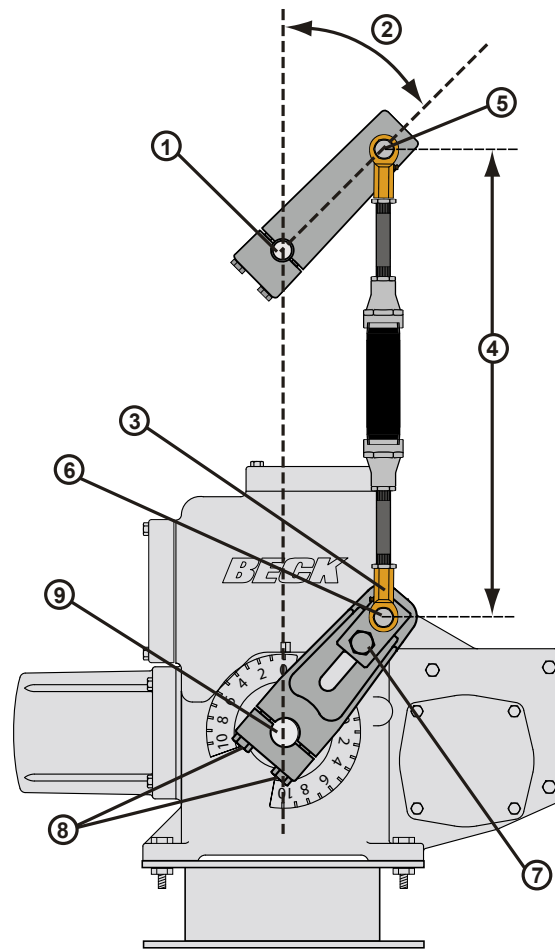

To adjust the linkage length, it is preferable to use the stud couplings. The couplings have right-hand and left-hand threads, so it is not necessary to disconnect the ends to make a length adjustment. Be careful not to expose more than 7" (178 mm) of stud between the rod end and coupling.



CAUTION

The thread engagement depth in the couplings and rod ends must be greater than 1.25 x the thread diameter.

Tighten crank pin screws and linkage lock nuts, and once again, check operation to confirm that no binding occurs between the linkage and crank arm, driven lever arm, or surrounding obstructions. Further travel adjustments can be made by repeating the above steps.

Tighten all lock nuts and screws to the specified torque value (see outline dimension tables).

Do not change limit switch settings to obtain desired valve or damper travel; this will adversely affect actuator operation.

INSTALLATION Electrical

POWER QUALITY

Power quality disturbances such as power outages, transient voltages, harmonic distortions, and electrical noise will adversely affect your actuator performance. Protecting your actuator from these conditions can reduce downtime and promote longer life for the equipment. Following the industry accepted standards below will help protect your actuator.

- ✦ Select wiring materials according to the correct ampacity ratings dictated by national and local regulations.
- ✦ Shielded, twisted pair cables can be used for signal connections to avoid being affected by electrical noise. These signal wires, based on Noise Susceptibility Level (NSL) per IEEE-518, fall into the level 1 classification. A braided shield will be more effective than a wrapped foil shield. Signal wire shields should be connected to the actuator casting grounding screw. If grounding at the signal source is required, then the shield should not be grounded at the actuator.
- ✦ Raceways such as conduits and trays must be grounded at both ends to properly meet immunity requirements.
- ✦ An AC power ground connection should be made between the power source and the Beck actuator. Grounding connections including wire and metal conduit are permitted, but the actuator-grounding conductor may not be connected to a structured metal frame of a building.
- ✦ Surge suppression equipment that meets Underwriters Laboratory (UL) Standard 1449 may be used to protect against transient voltage conditions.
- ✦ Power Conditioners may be used to regulate the supply voltage and maintain a constant voltage level. They are helpful in protection against voltage sags and swells, as well as some measure of electrical noise protection.
- ✦ Harmonic filters may be used to minimize the effects of supply voltage waveform distortions and are used in applications that incur a large amount of high-frequency electronic noise.



CAUTION

Always close covers immediately after installation or service to prevent moisture or other foreign matter from entering the actuator.

ELECTRICAL INSTALLATION

Two 1" N.P.T. conduit connections are provided for power and signal wiring to the actuator. Conduits should be routed from below the actuator so that condensation and other contaminants flow away from the conduit. All conduit entrances must be properly sealed in accordance with National Standards or Regulatory Authorities.

Power and signal wires should be routed to the actuator separately and be either shielded cables or installed in conductive conduit and/or cable trays.

Refer to the wiring diagram furnished with your Beck actuator for proper AC power and signal connections. The customer must supply 120 V ac to power the actuator (standard configuration). The 120 V ac line connects to terminal C and neutral to terminal B. Other available power options include 208, 240, 380, 415, 480 & 575 V ac.

It is advisable to provide normal short circuit protection on the AC power line. A copy of the wiring diagram is shipped with each actuator and is fastened to the inside of the terminal block cover. If there is no wiring diagram available, you may obtain a copy from Beck by providing the serial number of your actuator.

Connection of a 4-20 mA Demand signal should be made to terminals AA (+) and BB (-).

For maximum safety, the Beck actuator body should be grounded. Use the green grounding screw in the wiring compartment of the actuator.

TERMINAL SCREW TORQUES

Each terminal screw should be torqued to the proper specification upon landing the wire.

Models	Terminals	Torque	
		(lb-in)	(N•m)
All Models	A-V	16	1.8
	AA-EE	12	1.4
11-1__	FF-KK*	9	1.0
	1-3*	9	1.0
11-2__	FF-SS*	9	1.0
11-3__	1-3*	20	2.3
11-4__			

* Terminals included only with certain optional features.

INSTALLATION Wiring

Option 5, Modulating

Direct AC Control with Potentiometer Position Sensing

Customer must supply three wires to directly control the actuator motor direction: One 120 V ac line to run CW (terminal M), one 120 V ac line to run CCW (terminal N), and one neutral (terminal B). The position feedback potentiometer connections are available at terminals CC (reverse), DD (wiper), and EE (forward).

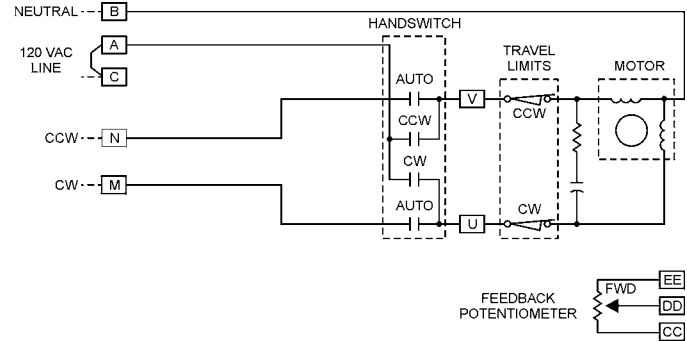

Option 4, Multi-Position

Direct AC Control with Cam-Operated Switches to Stop Actuator Travel

Customer must supply three wires to directly control the actuator motor direction: One 120 V ac line to run CW (terminal M), one 120 V ac line to run CCW (terminal N), and one neutral (terminal B). Up to six intermediate stop positions may be specified, each requiring an additional 120 V ac line. The diagram shows terminals F, N, K, D, M, and U.

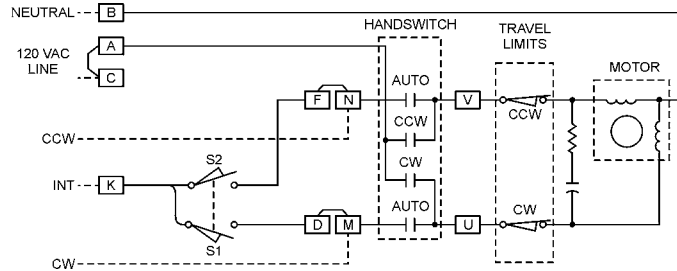

Option 3, Open / Close

Direct AC Control

Customer must supply three wires to directly control the actuator motor direction: One 120 V ac line to run CW (terminal M), one 120 V ac line to run CCW (terminal N), and one neutral (terminal B).

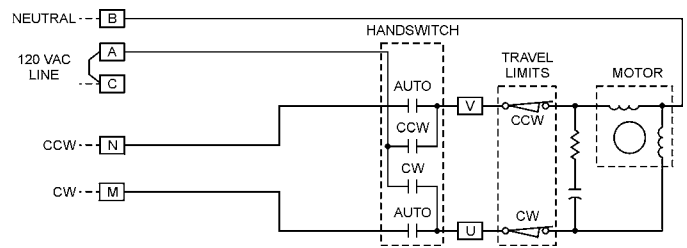

POWER CONNECTIONS FOR ALTERNATE POWER OPTIONS

Optional Transformer for 380, 415, 480, & 575 Volts

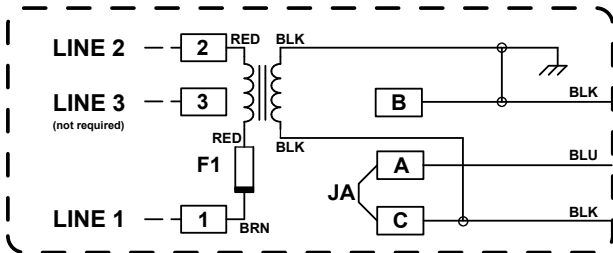

Optional Transformer for 208 Volts

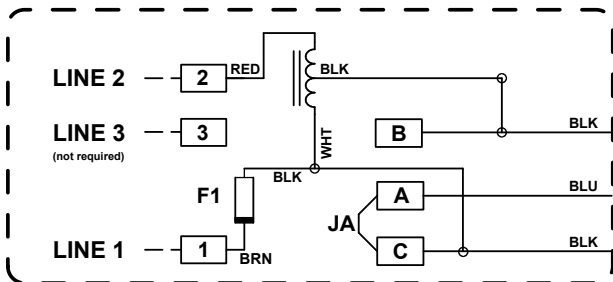

Optional Transformer for 240 Volts

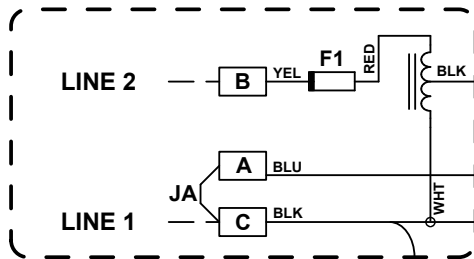

CONTACTLESS POSITION SENSOR (CPS-5) POSITION FEEDBACK SIGNAL CONNECTIONS

Beck actuators equipped with the Contactless Position Sensor (CPS-5) are shipped ready for installation.

Customer connections for feedback signal wiring are shown below. Refer to page 52 for additional information.

NOTE: For output shaft rotation of less than 80°, refer to Calibration Procedure, page 33.

CPS-5 Model 20-4400-02 Terminal Connections

1. A single 4–20 mA current output is available between terminals EE (+) and CC (-) when driving into an external load between 250 and 800 ohms. No ranging resistor is required.
2. 4–20 mA output is also available across EE (+) and DD (-); 500 ohms is the maximum external load (for larger loads see Item 1 above).

4-20 mA Signal Output

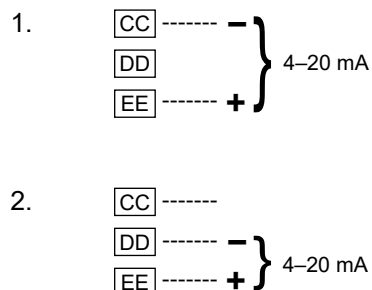

START-UP

NOTE: All Beck actuators are shipped from the factory ready for installation. Each actuator is set-up and calibrated to the customer's specifications that were written into the equipment order. Electrical adjustments are generally not required before placing the actuator in operation.

START-UP INSTRUCTIONS

After the actuator is mounted and its wiring connections are made, it is ready to be tested for proper operation.

Turn on the power supply. Operate the actuator with the Handswitch and run it through its full stroke, both directions. Observe that the driven device travels through its desired stroke. If satisfactory, set Handswitch to the "AUTO" position.

Operate the actuator using the Handswitch and observe that direction of travel is correct. When travel of the driven device is satisfactory with reference to the control signal or the push-buttons, the unit is ready for operation.

OPERATION

HOUSING

Beck electric actuators have individual cast aluminum compartments for each of the five main components: The control motor, wiring terminal block, drive train, control end, and relay board (if applicable). Gasketed covers and sealed shafts make the actuators ideally suited to outdoor and high humidity environments.

Heavy cast mechanical stops built into the housing are designed to prevent accidental over-travel damage during manual cycling, and ensure that proper orientation is maintained between the output shaft and the feedback system.

CONTROL MOTOR

The Beck control motor is a synchronous inductor motor which operates at a constant speed of 72 RPM or 120 RPM in synchronism with the line frequency.

Motors are able to reach full speed within 25 milliseconds and stop within 20 milliseconds; actual starting and stopping times will vary with load.

Beck motors have double grease-sealed bearings and require no maintenance for the life of the motor.

GEAR TRAIN

The gear train is a four-stage reduction, spur gear drive constructed with only heat-treated alloy steel and ductile iron gears for durability and long life.

The actuator train consists of the control motor and Handwheel, reduction gears, main gear, output shaft, and crank arm. The main gear / output shaft and third stage gears are common to all units of a particular actuator model. The second and first stage gears are part of the field-interchangeable gear module. Different combinations of gear modules and actuator motors determine the actuator's output torque and timing. See table on page 49 for details.

On standard models, the output shaft is limited by mechanical stops to 108° of rotation (98° on the 11-160). Optional main gear / output shaft assemblies are available that permit multi-revolution output rotation. Mechanical stops are not included on these models.

Mechanical transmission of output shaft position to the control end is provided by a right angle gear set driven directly by the output shaft.

SELF-LOCKING MECHANISM (SLM)

An integral part of every control motor is the self-locking mechanism. This mechanical device couples the motor to the gear train and transmits full motor torque when rotated in either direction. When the motor is de-energized, the SLM instantaneously locks and holds the output shaft in position.

HANDWHEEL

Every Beck actuator is furnished with a Handwheel to permit manual operation of the valve or damper without electrical power. Its solid construction design includes no spokes or projections, and turns at a safe, slow speed. The Handwheel is located at the rear of the control motor housing. The Handwheel is coupled directly to the motor shaft and rotates when the motor runs. Manual operation of the Handwheel (with electric Handswitch in "STOP" position) turns the motor and the rest of the actuator train without incorporating a clutch.

HANDSWITCH

A local electric Handswitch is provided on Beck actuators to permit operation at the valve or damper, independent of the controller. As a safety feature, the Handswitch is designed so that the controller can operate the actuator only when it is in the "AUTO" position. The sequence of the Handswitch is: "AUTO", "STOP", "CW", "STOP", "CCW".

In the "AUTO" position, two contacts are closed and the external controller contact completes the control circuit.

In the "CW" or "CCW" positions, contacts are closed to operate the actuator independently of the controller.

In the "STOP" position, all contacts remain open.

SWITCHES

Two over-travel limit switches (control options 5 thru 6) or two end-of-travel limit switches (control options 3 and 4) and up to four optional auxiliary switches are provided. Up to six optional auxiliary switches can be ordered with 11-2/-3/-406 (option 6) models only. Switch cams are clamped onto the control shaft which rotates in relation to the output shaft. Cam position is field-adjustable. Switches are rated 6 A, 120 V ac. All auxiliary switch connections are made on the terminal block.

OPERATION

CONTROL OPTIONS

120 V ac contact closure options are described below.

Open / close option 3: For simple 2-position control using manual push-buttons or an automatic controller. Preset end-of-travel limit switches provide open / close operation upon closure of an automatic controller or manually operated switch. Travel limits are adjustable over the full range of travel and provide precise positioning repeatability.

Multi-position option 4: Adjustable cam operated switches provide up to six discrete stop positions upon closure of an automatic controller or manually operated switch. Three, four, five, and six predetermined position settings are possible, with precise positioning repeatability.

Direct AC control option 5: Provides continuous positioning capability over the full range of actuator travel by direct AC control from either an automatic controller or manually operated switches. Includes a 1,000 ohm film potentiometer for remote feedback.

Direct AC control option 6: Provides continuous positioning capability over the full range of actuator travel by direct AC control from either an automatic controller or manually operated switches. Includes a Contactless Position Sensor (CPS-5) for feedback and position indication.

POSITION FEEDBACK: CONTACTLESS POSITION SENSOR (CPS-5)

The CPS-5 provides a continuous feedback signal proportional to the position of the actuator's output shaft. The position sensing function of the CPS-5 is provided by a ferrite magnetic sensing element. An electronic circuit translates the signal from the ferrite magnetic sensor into an analog position feedback signal designed to interface with electronic control systems and indicating instruments.

POSITION FEEDBACK: FILM POTENTIOMETER

The film potentiometer produces a voltage that is a fraction of the voltage applied across its resistive element. That voltage fraction is determined by the position of the wiper on the resistive element. The potentiometer assembly also includes two fixed resistors, one on each end of the resistive element. These resistors permit suppressed ranges as well as zero-based position feedback voltages.

STALL PROTECTION AND ANNUNCIATION

The Beck Stall Protection Module (SPM) is an optional feature for Group 11 actuators. The SPM monitors the motor current at terminals N and M. The SPM will be activated when the actuator cannot reach a desired position within approximately 300 seconds.

When a stall is sensed, the SPM shuts off power to the motor and a solid state relay in the SPM changes state. The relay is rated for 120 V ac or dc, 10 VA. Two terminals connected to the solid state relay are located on the SPM. Use of the relay for annunciation of a stall is optional and will not affect the other functions of the SPM. A sensed stall condition is cleared by either reversing the motor direction command in the controller or by turning the actuator power off and on. An LED is included on the SPM to show the operating status of the module.

CALIBRATION

CALIBRATION PRIORITY

Standard Group 11 actuators are equipped with fixed, non-adjustable, built-in mechanical stops. All output shaft rotation must occur within these stops, which are outside the electrical range of travel.

The over-travel or end-of-travel limit switches are used to limit the electrical control range of the actuator. These switches are cam operated and are set slightly wider apart than the actuator's intended full range of electronic operation for options 5 thru 6—typically 101° (11-15_/-20_/-30_/-40_) or 91° (11-16_/-26_/-36_/-46_). For options 3 & 4, the end-of-travel limit switches are set at the actuator's intended full range of operation—typically 100° (11-15_/-20_/-30_/-40_) or 90° (11-16_/-26_/-36_/-46_).

If the actuator is short-stroked—i.e., the full travel rotation from 0–100% is reduced to less than the standard 100° or 90° rotation—it may be desirable to reset the limit switches (see page 29). If the limit switches are not reset, Handswitch operation of the actuator (CW, CCW) will still result in the original full range of travel. It is best to calibrate the actuator and then set the limit switches when short-stroking the actuator. Over-travel limit switches (options 5 thru 6) should be set just outside the calibrated range to avoid tripping the switch at the 0% and 100% positions.

The auxiliary switches are also cam operated, but have no effect on actuator operation. Therefore, the auxiliary switches can be adjusted at any time without affecting performance or calibration.

CALIBRATION Switches

NOTE: Your Beck actuator was shipped from the factory ready for installation; no electrical adjustments are required before placing it in operation. Each actuator is set up and calibrated to the specifications that were written into the equipment order.

Under normal operating conditions there is no need to recalibrate the actuator. However, if the application requirements change—or are different than specified on the equipment order—the actuator should be recalibrated according to the following procedures.

SWITCH ADJUSTMENTS

Over-travel limit switches (options 5 thru 6) are factory set 1/2° outside each end of travel unless otherwise specified at time of order. End-of-travel limit switches (options 3 & 4) are factory set at each end of travel unless otherwise specified at time of order. Limit switches must be set inside the range of the built-in mechanical stops to prevent stalling of the motor. Limit switches can be reset to limit travel of the output shaft to any angle down to a minimum of approximately 60°. Auxiliary switches are set as shown in the illustration on page 29 unless otherwise specified at time of order.

NOTE: The limit switches are the switches closest to the actuator body. To adjust these switches, it is necessary to remove the control end cover.

Switches are operated by cams which are clamped onto the control shaft. Setting a switch involves loosening the cam, moving the output shaft to the desired position, and positioning the cam so that it just operates the switch at that point. In the following procedure, the use of a continuity meter is recommended to determine when the switch opens or closes. If such a meter is not available, it is possible to hear the switch click as the contacts open and close.



CAUTION

Do not attach the meter or attempt to move the switch cams until the actuator is disconnected from the line voltage and auxiliary switches are disconnected from external power sources.

SETTING LIMIT SWITCHES CW AND CCW

This procedure should be used if the factory limit switch settings must be changed in the field. It is advisable to operate the actuator fully in each direction, using the electric Handswitch to check switch settings before attempting to change them. Follow these instructions if they require adjustment:

NOTE: The rotation direction of the output shaft is the same as the control shaft except for models 11-1__, in which the shafts rotate in opposite directions.

1. Remove the control end cover (and extensions, if applicable) and terminal block cover (1/2" wrench).
2. Use the electric Handswitch to drive the control shaft so that the CW switch cam screw is accessible. Using a 7/64" hex wrench, loosen the screw so that the cam is just snug on the shaft (see photo, page 29).
3. Move the output shaft to the desired CW limit (for options 5 thru 6, this should be just outside the desired fully CW position).
4. Turn the Handswitch to the "STOP" position.
5. **Disconnect power from the actuator.**
6. Connect a continuity meter across terminals B and U. Rotate the cam until the meter shows no continuity (switch contacts open, switch clicks).
7. Tighten the cam locking screw to 5 lb-in (0.56 N•m) torque.
8. Disconnect meter and ensure the Handswitch is in the "STOP" position.
9. Reconnect actuator power.
10. Rotate the actuator's output shaft in the CCW direction away from the CW travel limit. Note the direction of rotation on the lobe of the cam. The correct cam lobe motion is away from the switch lever with the switch lever on the lower part of the cam. If not correct, return to step 2 and reset the cam to the proper orientation.
11. Rotate the output shaft again to the desired CW travel limit. If the stopping point is reached, the switch is properly set.
12. Repeat steps 2–11 for setting the CCW limit switch (CCW rather than CW). Connect continuity meter across terminals B and V.
13. Replace covers and tighten cover bolts to 10 lb-ft (14 N•m) torque.
14. Rotate index (or index pointer on models 11-1__) to correspond with output shaft rotation.

SETTING AUXILIARY SWITCHES

Standard switch settings for actuators with 2, 4 or 6 auxiliary switches are shown on the following diagram "Standard Limit and Auxiliary Switch Settings". The heavy line indicates a closed circuit. Follow these instructions to change the operating point of auxiliary switches:

NOTE: In the following procedure, it is assumed that switch settings are to be adjusted so that contacts are open when the desired position is achieved. If they are to be adjusted to close, it may be necessary to reverse the operating mode of the switch by reversing the leads on the switch itself. Be sure to disconnect power from the switch terminals first.

1. Remove the control end cover (and extensions, if applicable) and the terminal block cover (1/2" wrench).
2. Use the electric Handswitch to drive the shaft so that the switch cam is accessible. Using a 7/64" hex wrench, loosen the screw so that the cam is just snug on the shaft.
3. Move the output shaft to the desired switch trip position.
4. Turn the Handswitch to the "STOP" position.
5. **Disconnect power from the actuator and switch terminals.**
6. Connect the continuity meter across the appropriate terminals. See the specific actuator wiring diagram under the terminal block cover (or the generic diagram at right). Rotate the cam to operate the switch.
7. Tighten the cam locking screw to 5 lb-in (1 N•m) torque.
8. Disconnect the meter and reconnect power.
9. Move the actuator's output shaft in the desired direction to verify that the cam lobe moves away from the switch lever. If not correct, return to step 2 and reset the cam to the proper orientation.
10. Replace covers and tighten cover bolts to 10 lb-ft (14 N•m) torque.

SWITCH CAM ADJUSTMENT

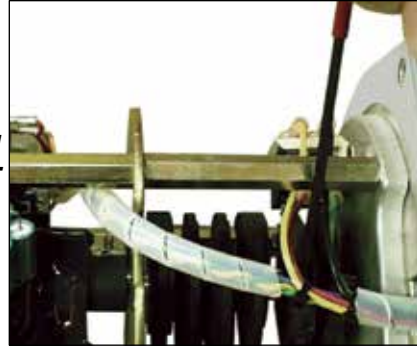

STANDARD LIMIT AND AUXILIARY SWITCH SETTINGS

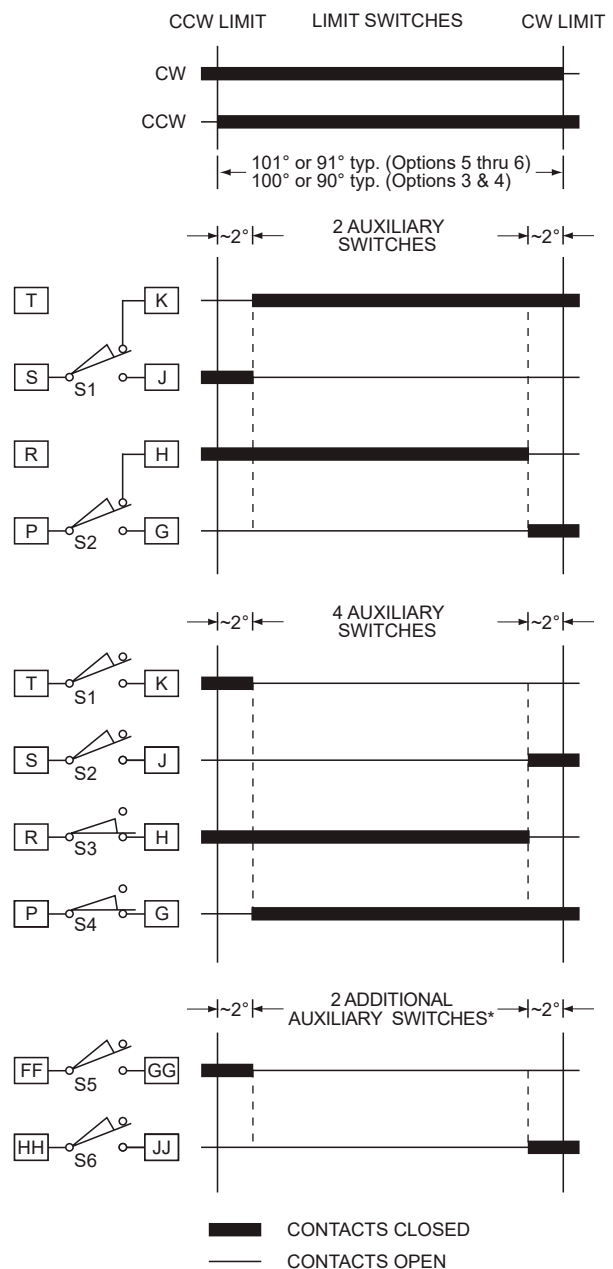

*Available with 11-2/-3/-406 models only

CALIBRATION *Direction Change*

DIRECTION OF OUTPUT SHAFT ROTATION

The direction of output shaft rotation is determined by observing the end of the actuator output shaft (see images below). The rotation direction desired from an increasing signal—clockwise or counterclockwise—should be specified at the time of order. If not specified, the output shaft is factory-set to rotate clockwise in response to an increasing signal.

NOTE: Changing direction of rotation does not change the setting of the auxiliary switches.

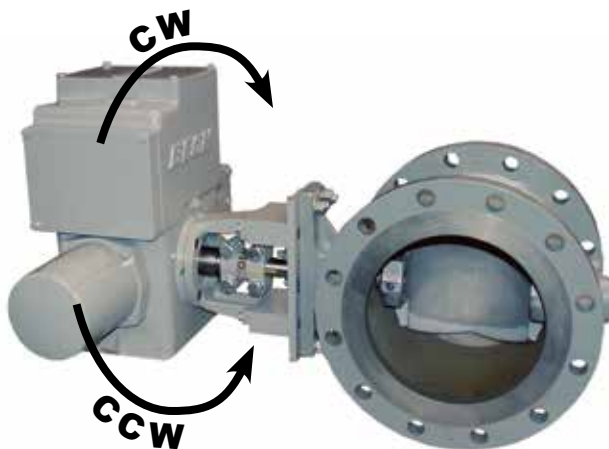
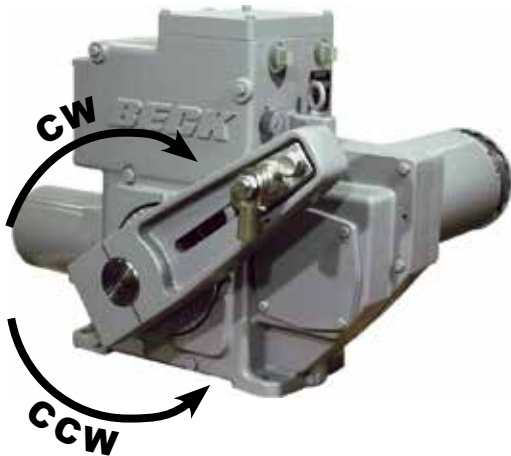

CHANGING DIRECTION OF OUTPUT SHAFT ROTATION

Procedures vary depending upon the actuator model number. The number is listed on the actuator nameplate. Determine the model number and refer to one of the following procedures.



CAUTION

Be sure the actuator is disconnected from the line voltage and that all auxiliary switches are disconnected from the external power sources before beginning the direction change procedure.

Models 11- __3 and 11- __4

No changes are necessary for these models other than resetting the travel index.

Model 11- __5

1. Remove the control end cover and extensions, if applicable (5/16" bolt heads).
2. Interchange the wires connected to terminals 1 and 5 of the potentiometer (i.e., the wire to terminal 1 should be moved to terminal 5 and vice versa). The wire to terminal 3 should not be moved (wiper connection).
3. Reset the travel index.
4. Reset the potentiometer wiper according to the film potentiometer calibration instructions on page 32.

Model 11- __6

1. Remove the terminal compartment cover, control end cover and extensions, if applicable (5/16" bolt heads).
2. Determine the correct feedback signals from the wiring diagram supplied with your actuator (CC, DD, EE).
3. Record the color and location of the feedback signal wires (for reconnection later). Remove the two feedback wires. Connect a mA meter in series with a 200Ω load resistor.
4. Reconnect actuator power.
5. Drive the output shaft until the CPS-5 output is 50% of the range (e.g., for 4–20 mA signal range, set output to 12 mA).
6. Ensure Handswitch is in "STOP" position.
7. Using a 7/64" hex wrench, loosen the CPS-5 rotor clamp.
8. Rotate the CPS-5 rotor 180° and set the

-
- output back to the mid-range (e.g., 12 mA).
9. Tighten the rotor clamp.
 10. Run the actuator to the 0% and 100% positions. Record the CPS-5 output at these positions.
 11. Subtract the outputs recorded at the two positions and compare with the desired output signal span (e.g., 16 mA for a 4–20 mA signal range). The difference between the measured span and the desired span is the span error.
 12. With the actuator at the 100% position, turn the span potentiometer to adjust the CPS-5 output signal by 1/2 of the span error calculated in step 12. Turning the span potentiometer CW increases the span equally at both ends. Turning the span potentiometer CCW decreases the span equally at both ends. See the figure on page 37 for the location of the span potentiometer.
 13. Loosen the CPS-5 rotor clamp and rotate to achieve the desired value of maximum output signal (e.g., 20 mA for a 4–20 mA signal range). Rotation of the CPS-5 rotor moves the entire signal range up or down.
 14. Tighten the CPS-5 rotor clamp to 5 lb-in (.56 N•m) torque. Maintain a 0.031" (.8 mm) clearance between the rotor clamp and stator.
 15. Run the actuator to the 0% and 100% positions and check the output signal for desired span. If incorrect, repeat the procedure from step 12.
 16. Remove the meter and resistor and reconnect the feedback wiring.
 17. Replace covers and tighten cover bolts to 10 lb-ft torque. Reset travel index.

CALIBRATION Feedback Signal

Feedback signal calibration is necessary to ensure that the signal correctly corresponds to the actuator's output shaft position. All actuators are shipped with the feedback calibrated for full 100° travel (90° for 11-16_/-26_/-36_/-46_) of the output shaft unless otherwise specified at the time of order. Minimum shaft travel available on Group 11 actuators is 60°.

The procedure to check and set feedback calibration varies by model number. The model number is listed on the actuator nameplate. Determine the model number and refer to the proper procedure below.

NOTE: The travel limit switches must be properly adjusted before the feedback signal is calibrated. The feedback signal must be calibrated before the demand Demand signal can be calibrated.

Film Potentiometer Calibration Models 11-__5

When properly adjusted, the auxiliary potentiometer feedback signal should be maximum with the actuator output shaft at the 100% (maximum Demand signal) position. At 50% of travel the signal should be mid-span. At the 0% position, the signal should be minimum.

If the feedback potentiometer is out of calibration:

1. Remove the control end cover (5/16" bolt heads).
2. Loosen the clamping screw (use 9/64" hex wrench) on the potentiometer wiper so that it is just snug on the shaft.
3. Move the actuator to the 0% position.
4. Set the wiper about 5 degrees above the position where the minimum output is reached, or as required by the control system.

NOTE: Be sure that the wiper spans the resistive and collector elements equally, and does not touch the areas of low resistance at either end of the film element.

5. Tighten the clamping screw to 5 lb-in (.56 N•m) torque.
6. Operate the actuator between the 0% and 100% positions. Verify that the feedback signal is properly adjusted.
7. Use the manual Handwheel to move the actuator to the mechanical limit; do not over-torque, as damage may result.

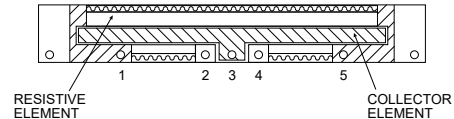

8. Check that the wiper does not come off the resistive element. This may be verified by monitoring the output voltage and ensuring it does not fall from maximum value. If not correct, return to step 2.
9. Replace the control end cover. Torque the cover bolts to 10 lb-ft (14 N•m).

CPS-5 Calibration Model 11-__6

These models are equipped with a Contactless Position Sensor (CPS-5) for position sensing and feedback.

CPS-5 units are designed to provide position feedback without contacting or wiping surfaces.

The CPS-5 provides infinite resolution by incorporating a ferrite rotor on the control shaft and a ferrite stator mounted on the position sensing circuit board. To adjust the feedback signal, first adjust the span, then change the position of the rotor on the control shaft to adjust the zero.

Checking Feedback Signal Calibration

The following procedure should be followed to check CPS-5 calibration:

Tools required:

- mA / V dc Multimeter
- 1/2" Combination Wrench
- 200Ω Resistor

1. Put electric Handswitch in "STOP" position.
2. Remove the terminal cover and the control end cover (5/16" bolt heads).
3. Determine the correct feedback terminals from the wiring diagram supplied with your actuator (CC, DD, EE).
4. Record the color and location of the feedback signal wires (for reconnection later). Remove the two feedback wires. Connect a mA meter in series with a 200Ω load resistor.
5. Drive the output shaft through its full range and check the feedback signal. When properly adjusted, the feedback signal should be maximum with the actuator's output shaft at the 100% (maximum Demand signal) position. At 50% travel the signal should be mid-span. At 0%, the signal should be minimum. If not correct, proceed with the calibration procedure.

NOTE: Tolerance on factory calibration is $\pm 0.5\%$ of span.

Calibration Procedure

Adjustment of the CPS-5 is necessary if the signal range requires an increase or decrease in value relative to the actuator's output shaft rotation. Calibrate by turning the span potentiometer CW to increase the gain of the CPS-5. This has the effect of increasing the output at the high end and lowering the output at the low end equally.

To adjust the signal span, turn the span potentiometer on the CPS-5 position sensor board (see figure on next page). The span potentiometer adjusts the CPS-5 so that an actuator output shaft rotation from 80° to 100° produces the specified output signal range.

For output shaft rotation of between 60° and 79°, it may be necessary to remove resistor R8 (100K Ω) to change the range of the span adjustment. An R8 value of 100K Ω produces a shaft output range of 80° to 100°; an R8 value of 249K Ω produces a shaft output range of 70° to 79°; and removing R8 produces a shaft output range of 60° to 69°. See the figure on the next page for the location of R8 (positioned on raised turrets).

Tools required for calibration:

- mA / V dc Multimeter
- 3/32" Screwdriver
- 7/64" Hex Wrench
- 1/4" Screwdriver
- 1/2" Combination Wrench
- 1/32" (.8 mm) Thickness Feeler Gauge
- 200 Ω Resistor

1. Put electric Handswitch in "STOP" position.
2. Remove the terminal cover and the control end cover (5/16" bolt heads).
3. Determine the correct feedback terminals from the wiring diagram supplied with your actuator (CC, DD, EE). This wiring diagram is located under the terminal cover.
4. Record the color and location of the feedback signal wires (for reconnection later). Remove the two feedback wires. Connect a mA meter in series with a 200 Ω load resistor.
5. Move the actuator to the 0% and 100% positions and record the CPS-5 output at these positions.
6. Subtract the outputs recorded at the two positions and compare with the desired output signal span (e.g., 16 mA for a 4–20 mA signal range). The difference between the measured span and the desired span is the span error.
7. With the actuator at the 100% position, turn the span potentiometer to adjust the CPS-5 feedback signal by 1/2 of the span error calculated in step 6. Turning the span potentiometer CW increases the span equally at both ends. Turning the span potentiometer CCW decreases the span equally at both ends. See figure on the next page for the location of the span potentiometer.
8. Loosen the CPS-5 rotor clamp (see figure next page) and rotate to achieve the desired value of maximum output signal (e.g., 20 mA for a 4–20 mA signal range). Rotation of the CPS-5 rotor moves the entire signal range up or down.
9. Tighten the CPS-5 rotor clamp to 5 lb-in torque. Maintain a 0.031" (.8 mm) clearance between the rotor clamp and stator.
10. Run the actuator to the 0% and 100% positions and check the feedback signal for desired span. If not correct, repeat the procedure from step 5.
11. Remove the meter and resistor, then reconnect the feedback wiring.
12. Replace covers and tighten the cover bolts to 10 lb-ft (14 N•m) torque.

CALIBRATION Feedback Signal

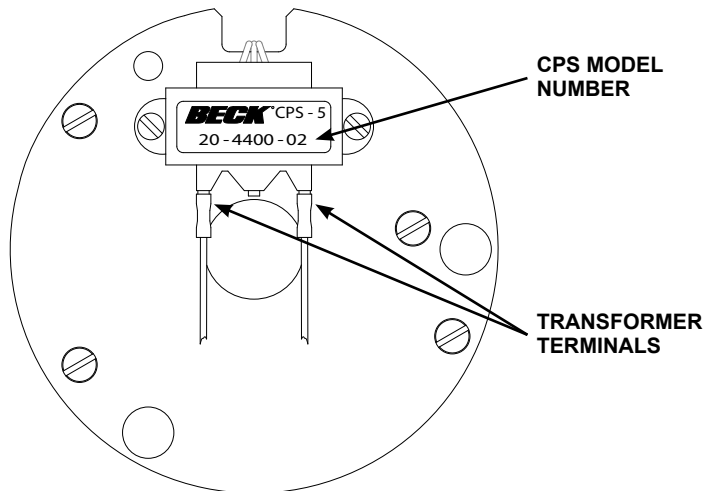

CPS-5 (TRANSFORMER SIDE)

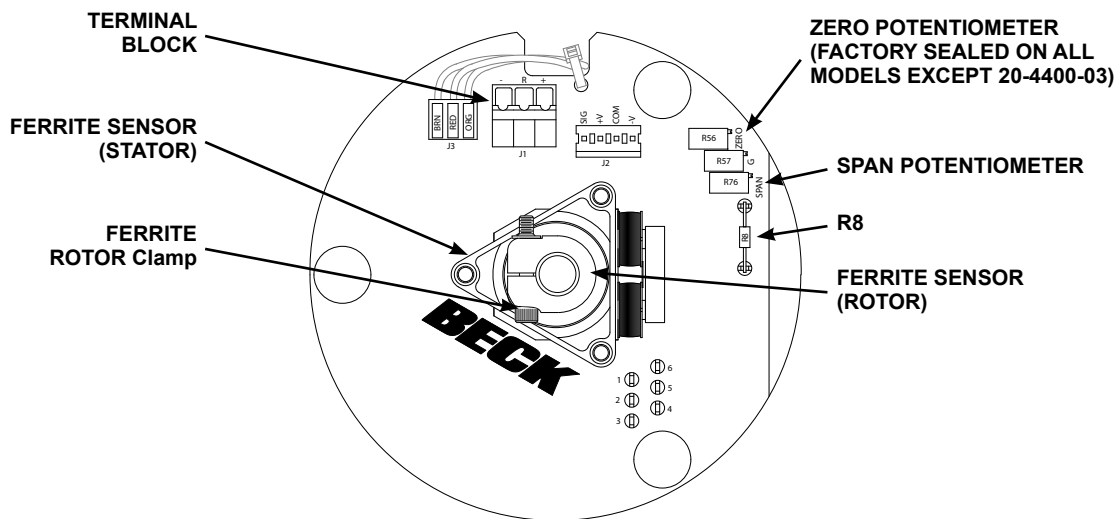

CPS-5 POSITION SENSOR

CALIBRATION Demand Signal

RELAY BOARD OPERATION AND CALIBRATION

The Relay board is a solid-state interface to permit switching large control motor currents with low-current ac or low-voltage dc inputs.

Low-current 120 V ac Relay Board Calibration Procedure (Relay Board 13-2246-50):

NOTE: When used in low-current AC applications, the Relay board provides a load of 10 mA to the controller. If the controller requires a larger minimum load, the user must provide additional load external to the control drive.

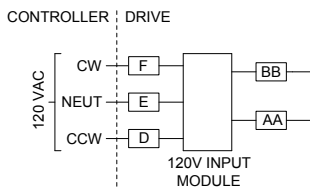

1. Disconnect the actuator from line voltage and remove the terminal cover and Relay Board cover (5/16" bolt heads).
2. Remove control signal wires from terminals D, E and F.
3. Attach a voltmeter to test points TP1 (+) and TP2 (-). See figure below for location of test points on the Relay board.
4. Turn on line voltage.
5. Adjust potentiometer R3 to bring the meter reading to +0.17 volts (± 0.01 V dc). See figure below for location of potentiometer R3.
6. Disconnect the actuator from line voltage and reconnect control signal wires to terminals D, E and F.
7. Check operation of the actuator with system signals.
8. Replace covers and tighten cover bolts to 10 lb-ft (14 N•m) torque.

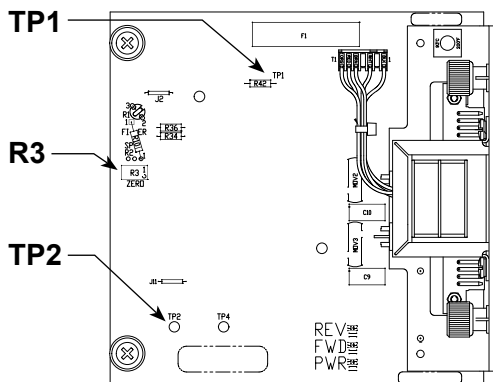

Low Current 120 V ac
Relay Board Components

Low-voltage 24 V dc Relay Board Calibration Procedure (Relay Board 13-2246-51):

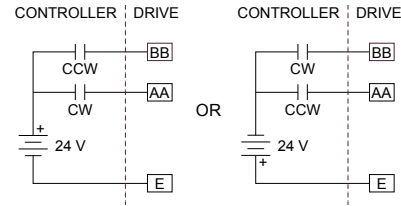

1. Disconnect the actuator from line voltage and remove terminal cover and Relay Board cover (5/16" bolt heads).
2. Remove control signal wires from terminals AA and BB.
3. Attach voltmeter to test points TP1 (+) and TP2 (-). See figure below for location of test points on the Relay board.
4. Turn on line voltage.
5. Adjust zero potentiometer R3 for -0.2 V at TP1 with neither Demand signal applied. See figure below for location of zero potentiometer R3.
6. Adjust span potentiometer R2 for -0.2 V at TP1 with both control signals applied simultaneously. See figure below for location of span potentiometer R2.
7. Disconnect the actuator from line voltage and reconnect control signal wires to terminals AA and BB.
8. Check operation of the actuator with system signals.
9. Replace covers and tighten cover bolts to 10 lb-ft (14 N•m) torque.

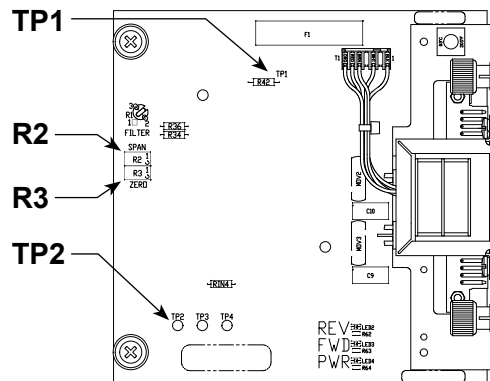

Low Voltage 24 V dc
Relay Board Components

MAINTENANCE Routine

LUBRICATION / GEARING

Periodic lubrication is not required on Beck actuators. However, if your actuator has a linkage with rod ends supplied by Beck, the rod ends should be included in your scheduled lubrication program.

During major maintenance outages, it is recommended that older actuators should be inspected to ensure that the gearing is not worn or damaged.



CAUTION

Before removing the gear module assembly from the actuator body, secure the output shaft to prevent movement.

To inspect the gears, remove the gear module assembly on the 11-2__, -3__ and -4__. On Model 11-1__, the motor must be removed to access the gears. Clean the gears, removing as much old lubrication as possible.

Examine the gear teeth, shaft bore, and gear shafts for signs of excessive wear, scoring, or other damage. If there is no evidence of damage to the gearing, recoat the teeth and shaft bores of all gears with a heavy layer of Fiske Lubriplate GR-132 or equivalent (GR-132 is an extreme pressure grease with polymer additives). The ball bearing on the output shaft and crown gear shaft have double grease seals and require no maintenance for the life of the bearings. Inspect all other grease seals and replace any that show wear. Reassemble the actuator, referencing the outline dimension drawings beginning on page 6 for appropriate bolt torques.

If it should ever be necessary to replace the output shaft assembly, 3rd combination gear, or output shaft bearings, a major overhaul is required and the actuator must be returned to the factory for a repair evaluation.



11-4__ Gear Module

MAINTENANCE *Component Replacement*

This section covers replacement of many components of the actuator. Note that some components are not field-repairable. Refer to the outline dimension drawings on pages 6–11 and to the cutaway drawings in the components appendix for location of components on the actuator.

If it should ever be necessary to replace the output gear, shaft, or output shaft bearings, a major overhaul is required and the actuator should be returned to the factory. During a major overhaul, the factory repair department will update the actuator to include all possible engineering improvements. See "HOW TO OBTAIN SERVICE" at the end of this manual.

Gaskets

During routine service, inspect removed cover gaskets for wear or damage. In order to protect internal components, worn or damaged gaskets and O-rings should be replaced.

To remove, scrape all of the old adhesive and gasket material from the body housing and cover, if necessary. Replacement gaskets are self-adhering, silicone rubber. Peel the backing off the replacement gasket and carefully apply to the actuator body.

Seals

Worn or damaged output shaft, control end shaft, and motor shaft seals should be replaced to prevent damage to internal bearings and drive train parts.

To remove the shaft seal, push the blade of a small screwdriver along the shaft and under the seal lip. **CAUTION:** The seal is approximately 1/4" (6.35 mm) wide. Do not force the screwdriver blade beyond the width of the seal; damage to the shaft bearing could result. Pry up on the seal and force it out of the housing. Clean the shaft and housing then press in the replacement seal with the closed side facing outward.

Bearings

The Beck electric actuator contains ball bearings on the output shaft, control end shaft, and motor shaft. Bushings and thrust washers are used on combination gears. Field replacement of these components is not recommended.

Motor shaft bushings in the body of the 11 -1__ and 11-4__ can be replaced. **TIP:** To remove, fill the bushing with a heavy grease. Select a drive pin that slip fits into the bushing. Insert the pin into the bushing and tap with a mallet. This will force the bushing out of the body casting.

Motor

The control motor is not field-repairable. Disassembly of the motor will result in a loss of torque that can only be restored by returning the motor to the factory for re-magnetizing.



CAUTION

Before removing the control motor, block the actuator crank arm to prevent the crank arm and the gear train from moving when the motor is removed.

To remove the motor, first disconnect the motor wires in the terminal compartment of the actuator. In the 11-2__, -3__, and -4__ actuators, remove the terminal block and plate as an assembly. Remove the black wire from the terminal post, cut the red motor wire near the red-yellow-red butt joint and disconnect the green wire from the motor capacitor. Remove the mounting bolts and motor. Carefully slide the motor out of the actuator body.

To install the motor, insert the three-wire sleeve through the wire hole in the motor mount and into the terminal compartment. Carefully slide the motor into the actuator body. Rotate the motor shaft, if necessary, to engage the pinion with the first combination gear. Install motor mounting bolts and torque to recommended values. Reconnect the motor wires. See the following section for reinstalling the terminal plate.

Motor Resistor and Capacitor

The motor resistor and capacitor are located under the terminals in the terminal compartment. To replace a resistor or capacitor, remove the terminal cover. In the 11-2__, -3__, and -4__, remove the terminal plate. Remove the existing part and transfer the wires one at a time to the replacement part. Inspect the terminal plate gasket and replace if necessary. To ensure a watertight seal between the plate and gasket, coat the gasket with a thin film of grease before replacing the terminal plate. Torque the screws to 3 lb-ft (4 N•m).

MAINTENANCE Component Replacement

SELF LOCKING MECHANISM (SLM)

The Self Locking Mechanism (SLM) is assembled to the front of the motor and couples the motor to the gear train. The primary function of the SLM is to lock the gear train in place when the motor is de-energized. When the motor is energized, the SLM releases and allows the motor to drive the gearing.

There is no recommended maintenance interval for the SLM. The SLM can last for many years in normal service. SLM wear is a function of loading and the number of starts/stops the motor experiences over time. Overloading or stalling the actuator will accelerate SLM wear.

Signs of wear include the inability of the actuator to hold position when the motor is de-energized. This could result in persistent on-off oscillation. Severe SLM wear or damage may result in a loss of torque at the output shaft.

It is often possible to confirm SLM wear or damage by checking motor operation with the Handwheel. Place the Handswitch in the STOP position, and rotate the motor Handwheel back and forth. There should be free play before the motor pinion/gearing turns (up to one tenth of a full Handwheel rotation). Lack of free play or rough motor movement may indicate the need for SLM reconditioning.

Disassembly and close inspection of the SLM components is required to fully evaluate its condition.



WARNING

Electrical shock hazard. Disconnect power before proceeding.

Support the load before removing the motor/SLM from the actuator.

SLM REBUILD KIT MAJOR COMPONENTS (Descriptions & Part Numbers)

Model Number	11-1__		11-2__ / 11-3__		11-4__		
Motor Assembly	20-2204-20, 20-2204-21	20-2700-20	20-2701-20, 20-2701-51	20-2704-21	20-2705-21, 20-2705-51	20-2201-31, 20-2201-32, 20-2201-33	20-2201-35
Rebuild Kit (NF-119)	N/A	12-8060-15	12-8060-16	N/A	N/A	N/A	N/A
Rebuild Kit (GL181-134)	12-8066-38	N/A	N/A	12-8066-39	12-8066-40	12-8067-13	12-8067-14
Spring	14-9980-01	14-9980-10	14-9980-12	14-9980-01	14-9980-06	14-9980-26	
Friction Material (NF-119)	N/A	13-0080-04		N/A		N/A	
Friction Material (GL181-134)	14-9409-58	N/A		14-9409-58		14-9409-52	
Spring Pin	10-7111-03	10-7111-06		10-7111-03		10-7111-05	
Stop Collar	14-9380-10	14-9380-09		14-9380-08		N/A	
Thrust Washer/Bearing	14-9400-21	14-9400-16		13-0350-01		14-9400-02	
Pinion	14-9940-44	14-9940-10		14-9940-06		14-9940-17	14-9701-12
Steel Ball	14-9420-01 (8)	14-9420-02 (6)		14-9420-01 (8)		14-9420-03 (8)	
Locking Disc	14-9330-05	14-9330-15		14-9330-05		14-9330-19	
Steel Shim	30-0315-23			30-0315-45 (2)		N/A	
Steel Shim	30-0315-24			30-0315-46 (2)		N/A	
Motor Gasket	20-0660-15			20-0660-27		20-0660-08	
Instruction Sheet	80-0016-16	80-0016-05		80-0016-07		80-0016-02	
Terminal Joint	20-0032-01 (3)						
Slip-on Terminal	20-0030-01						
Spacer	N/A					20-2090-03	20-2311-07
O-ring	N/A					14-9840-16	
Motor Screw	30-0307-35 (4)			30-0311-86 (4)		30-0306-40 (4)	

DISASSEMBLY AND CLEANING

When wear or damage is suspected, disassembly and cleaning may be required to determine the extent of needed repairs. Individual parts may be replaced, with the exception of the actuator collar, which is not field replaceable. Refer to the illustration at right.

For SLM disassembly and inspection:

1. Disconnect power from the actuator.
2. Secure the actuator load, and remove the motor assembly (see page 37). Handle the motor with care so as not to damage the rotor shaft.
3. Pushing down firmly on the pinion, measure the gap between the stop collar and the thrust washer. This distance should measure 0.015 ± 0.005 " for motors on models 11-1__, 11-2__, and 11-3__. This distance should measure $0.025 \pm .005$ " for motors on models 11-4__. An excessive gap indicates worn SLM components.
4. Use a felt tip pen to mark the location of the stop collar (or castle nut) on the shaft. Support the end of the rotor shaft to prevent it from bending, and drive the 1/8" spring pin out (or loosen the castle nut). Carefully (the spring assembly is spring-loaded), remove the stop collar (or castle nut), thrust washer/bearing, spacer (models 11-4__ only), pinion, spring, and steel balls. On 11-4__ models, remove the (4) 1/4-20 screws and the front motor end (see the 11-4__ SLM Components figure at right). DO NOT remove the front motor shield or the rotor from the stator on any model.



CAUTION

Do not disassemble the motor any further, as it has no other user serviceable parts. Further disassembly will result in demagnetization of the motor and loss of the required torque.

5. Clean grease from the pinion and locking disc for inspection. A small amount of dust residue from the friction material is normal. Clean the actuator collar detents with a rag and inspect for wear. Inspect the friction material for excessive wear or damage. If the friction material does not appear to be damaged, clean with alcohol to remove any contaminants.
6. Identify worn parts and replace as needed. Note, wear on the pinion teeth may indicate wear on the meshing gear. Further inspection of the gear module assembly is recommended. Drive collar detent wear will require factory repair of the motor.

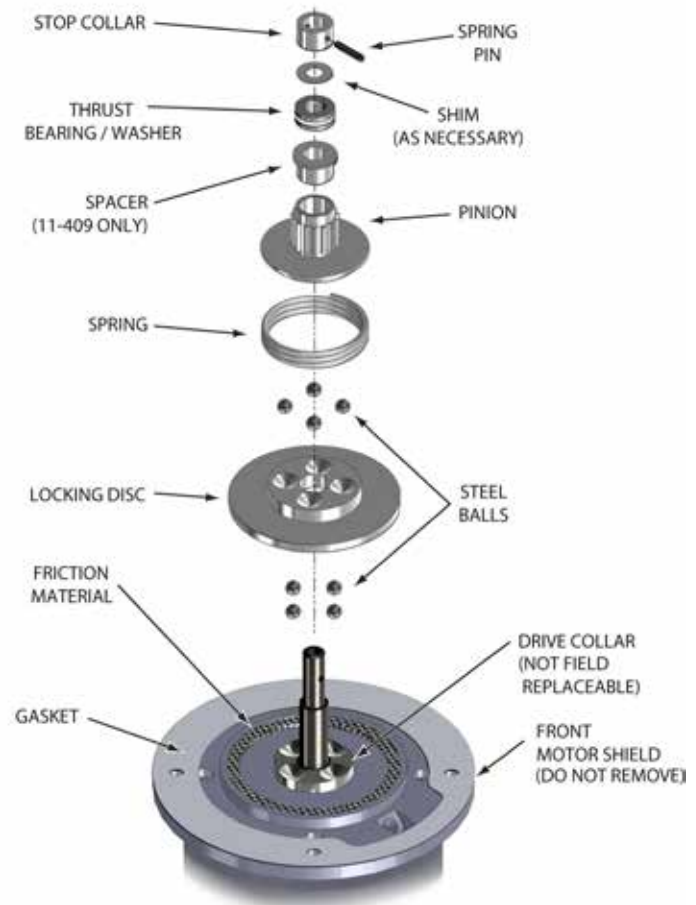

11-1/2/3__ SLM COMPONENTS

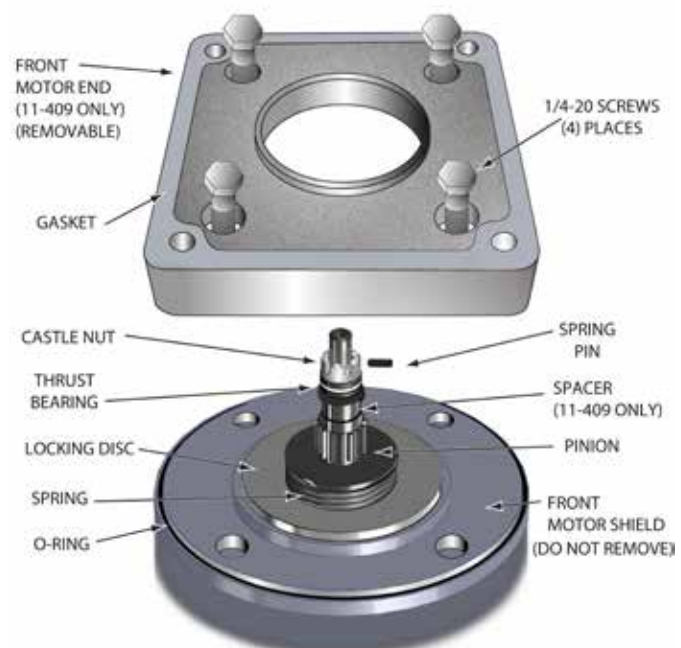

11-4__ SLM COMPONENTS

MAINTENANCE Component Replacement

SLM REPLACEMENT AND REBUILD INSTRUCTIONS

1. If the friction material requires replacement, scrape off the old friction material and thoroughly clean the bonding surface to ensure flatness for the new friction material. Glue the new friction material in place with Loctite 454 Instant Adhesive or equivalent, taking care to keep the material flat and clean.
2. Apply a film of grease (Fiske Lubriplate GR-132 or equivalent) to the surface of the ball detents (12 or 16 places depending on the model). Apply a *thin* film of grease to the inner diameter of the locking disc bore. Do not let the grease contact any friction surfaces. Excess grease can contaminate the friction surface and reduce SLM effectiveness.
3. With the motor shaft pointed up, place a steel ball into each of the actuator collar detents. Install the locking disc and place a steel ball into each of the detents on the top of the locking disc.

Continue with the appropriate steps for your model number as follows:

Models 11-1__ , 11-2__ & 11-3__

4. Install the pinion, thrust bearing/washer, and stop collar as follows: On model 11-1__ actuators, the white side of the thrust washer should face the pinion. Make sure all steel balls are properly seated in the detents of the drive collar, locking disc, and pinion. Align the stop collar with the shaft marks made during disassembly and insert a 1/8" pilot punch through the stop collar hole and into the motor shaft to hold it in place.
5. Pushing down firmly on the pinion, measure the gap between the stop collar and the thrust bearing/washer. This distance should measure $0.015 \pm .005$ ". This space is necessary to ensure proper operation. Add/remove shims as necessary. Install the new 1/8" spring pin while supporting the shaft.
6. Install the spring by slipping it over the pinion flange and twisting it into place.
7. On model 11-1__ actuators, reassemble combination gears onto the motor end. On all models, recoat the gear teeth and components above the pinion liberally with a layer of Fiske Lubriplate GR-132 or equivalent.

Models 11-4__

4. Install the spring on top of the locking disc. Compress the spring by pushing down with the pinion. While holding the pinion in place, install the spacer, thrust bearing, and castle nut (stop collar). Note: The grooved washers on each end of the thrust bearing have differently sized holes; the end with the washer having the smallest hole should be installed next to the castle nut. Thread the castle nut onto the shaft to hold the spring in compression.
5. Replace the front motor end O-ring (see figure below) and install the front motor end with the (4) 1/4-20 screws in a crisscross pattern, torquing to 6 lb-ft (8 N•m). Place RTV around the wire entry into the motor.
6. Pushing down firmly on the pinion, measure the gap between the castle nut and the thrust bearing. This distance should measure $0.025 \pm .005$ ". This space is necessary to ensure proper operation. Tighten or loosen the castle nut as necessary to achieve the proper gap and simultaneously align one of the slots with the hole in the motor shaft. One complete slot rotation will change the gap by 0.009". Install the new 1/8" spring pin while supporting the shaft.
7. Recoat the gear teeth and components above the pinion liberally with a layer of Fiske Lubriplate GR-132 or equivalent.

OVER-TRAVEL LIMIT AND AUXILIARY SWITCHES

Complete switch assemblies may be replaced. It is not possible to replace individual switches. To replace switch assemblies, follow the instructions below.



WARNING

Electrical shock hazard. Disconnect power before proceeding.

Remove the control end cover by loosening the four captive, socket head cap screws (1/2" wrench). Remove the screws holding the switch assembly to the switch plate and slide it out to the side.

Transfer the wires to the terminals of the replacement assembly, ensuring the correct wire is transferred to the correct replacement assembly terminal (wires have push-on lugs). Install the replacement assembly and note that it rotates around one screw to permit an adjustment of the cam-to-switch lever spacing and switch operating point. To set the switch, place a .030" (.75 mm) shim between the cam and switch lever (see photo to right). The switch lever should be on the low or minimum radius portion of the cam when setting the switches. Position the switch assembly so that the switch is just actuated. DO NOT overstress the switch lever. Tighten both screws to 10 lb-in (1 N•m) torque and remove the shim.

ADDING AUXILIARY SWITCHES

It is sometimes possible to add auxiliary switches in the field. If the actuator was built with two or less auxiliary switches, they may be added in multiples of two, for a total of up to four auxiliary switches. See the table at right for part numbers.

Install wiring onto the switch push-on lugs and route the wires into the actuator terminal area. Remove the terminal compartment cover and solder wires to the underside of the terminal board according to the wiring diagram included with the new switch assembly. Install the new switch assembly and adjust according to the preceding instructions.

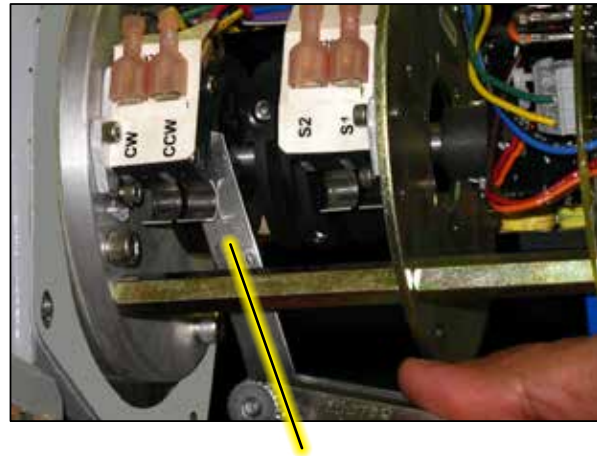

.030" (.75 mm) shim should be inserted between all levers and cams when setting switches.

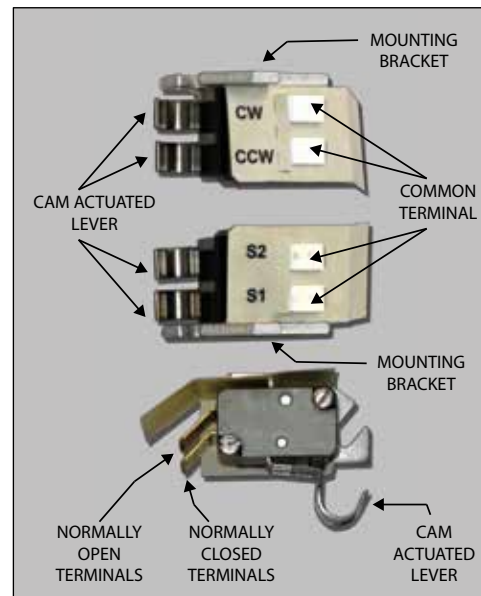

SWITCH PARTS

Description	Part Number
Over-travel limit switch assembly (CW/CCW)	20-3202-10
Auxiliary limit switch assembly, (2) switches (S1/S2)	20-3202-11
Auxiliary limit switch assembly, (4) switches (S1/S2/S3/S4)	20-3202-12
Limit switch cam assembly	11-0931-02

MAINTENANCE Component Replacement

FUSE (F1) REPLACEMENT (FOR ACTUATORS EQUIPPED WITH OPTIONAL 208V OR HIGHER POWER SUPPLY)

If it is necessary to replace the power fuse (F1), use the following procedure:



WARNING
Electrical shock hazard. Disconnect power before proceeding.

Remove the terminal block cover. Locate the fuse holder (similar to the illustration below).

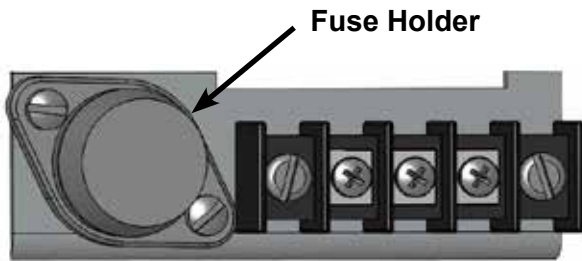

Turn the fuse holder CCW while pressing down. The fuse holder should spring loose when free. Remove the fuse holder from the actuator. Pull the fuse free from the holder. Replace the fuse with the same type (see table below) by pushing it into place.

Reinsert the fuse holder into the actuator. Turn the fuse holder CW while pressing down to tighten. Replace the terminal block cover. Tighten the cover screws to 6 lb-ft (8 N•m) torque.

REPLACEMENT FUSES (F1)

Actuator	Input Voltage	Amps	Volts	Type	Part No.
11-150 -160	208	0.75	250	Time Delay	11-1370-23
	240	0.75	250	Time Delay	11-1370-23
	380	0.4	600	Time Delay	11-1372-18
	480	0.3	600	Time Delay	11-1372-17
	575	0.25	600	Time Delay	11-1372-28
11-200 -260 -300 -360	208	1.0	250	Time Delay	11-1370-24
	240	1.0	250	Time Delay	11-1370-24
	380	0.6	600	Time Delay	11-1372-14
	480	0.5	600	Time Delay	11-1372-27
	575	0.4	600	Time Delay	11-1372-18
11-400 -460	208	3.2	250	Time Delay	11-1370-25
	240	3.2	250	Time Delay	11-1370-25
	380	1.8	600	Time Delay	11-1372-32
	480	1.4	600	Time Delay	11-1372-30
	575	1.25	600	Time Delay	11-1372-29

RELAY BOARDS

The Relay Boards (13-2246-50 & 13-2246-51) are not field repairable and must be replaced if there is an issue.



WARNING

Electrical shock hazard. Disconnect power before proceeding.

To replace a Relay Board, remove the Relay Board compartment cover (four captive, 5/16" hex head screws). Loosen the four captive screws holding the board to its mounting pads. Note the "L" shaped mounting bracket on the end of the board. To remove the board, pull the mounting bracket away from its mating surface and connector receptacle, using a gentle, rocking motion.

To install a Relay Board, lightly press the board connector into its receptacle until the mounting bracket is flush with its mating surface. Tighten the four captive screws to 8 lb-in (0.9 N•m). Replace the Relay Board compartment cover and tighten the cover screws to 10 lb-ft (14 N•m) of torque.

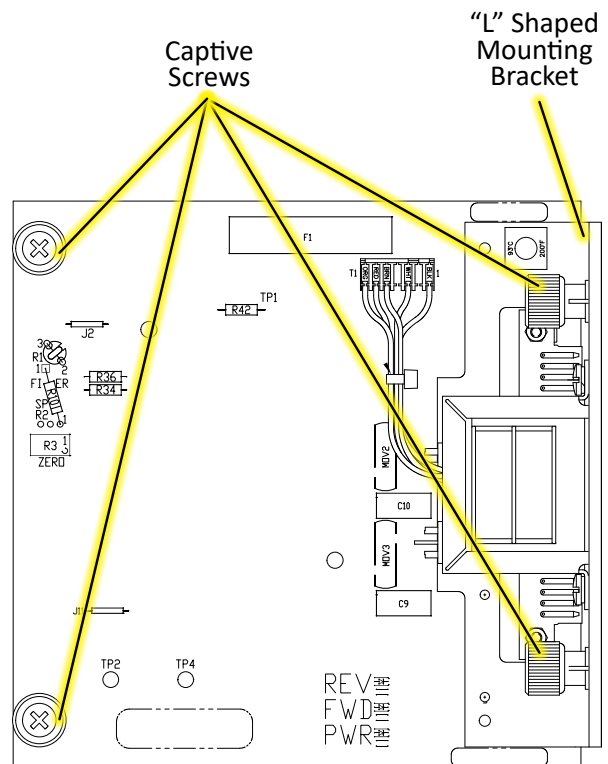

CPS-5

Field repair of the CPS-5 is not recommended.



WARNING

Electrical shock hazard. Disconnect power before replacing the CPS-5.

When replacing the CPS-5, this includes the rotor and stator/circuit board assembly. When returning the CPS-5 to the factory for service, do not separate the rotor and stator/circuit board assemblies from their mounting plates. The rotor should be held inside the stator with rubber bands when shipping.

The CPS-5 is configured to produce a position signal voltage between 1 and 5 volts over 100 degrees of travel; units configured for 90 degrees of travel will produce a position voltage between 1.2 and 4.8 volts. Configured properly, the CPS-5 raw position signal (measured at TP1 & TP4) increases as the output shaft rotates clockwise.

REMOVE THE EXISTING CPS-5 ASSEMBLY:

1. Run the actuator to its midpoint of travel with the local Handswitch.
2. Disconnect 120 V ac power to the actuator. Remove the terminal and control end compartment covers (1/2" wrench).

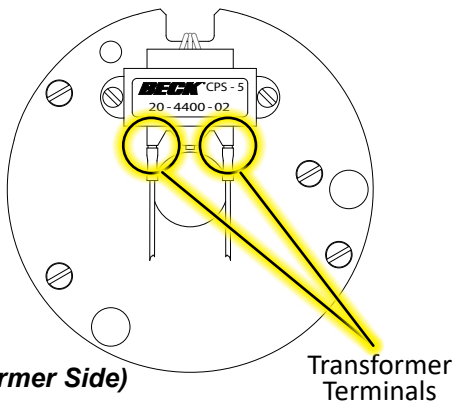

**CPS-5
(Transformer Side)**

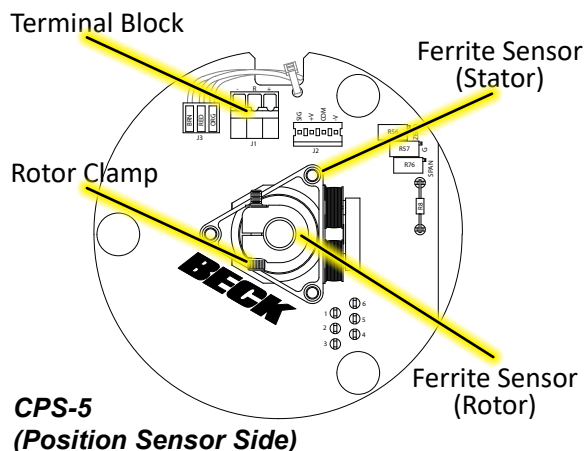

**CPS-5
(Position Sensor Side)**

3. Record the wire colors on the terminal block of the CPS-5 (see illustration at left), then disconnect the wires. The terminals are spring-loaded. To remove a wire, press the tip of a small screwdriver into the slot at the top of the small lever. Push down to open the spring-loaded contact and release the wire.
4. Pull the wires from the transformer (see illustration) back through the wire hole in the CPS-5.
5. Loosen and remove the 3 hex studs that clamp the CPS-5 in place. Ensure that the inboard hex stud is not loosened as the outboard stud is loosened.
6. Slide the CPS-5 stator assembly off the three mounting bolts.
7. Note the position of the rotor clamp, then loosen the rotor clamp screw and remove the rotor from the shaft.

INSTALL THE NEW CPS-5 ASSEMBLY:

8. Remove the rotor from the replacement CPS-5 assembly. Slide the rotor, clamp end first, onto the control shaft as close to the mounting plate as possible. Leave the clamp loose. Position the clamp similarly to the one removed previously.
9. Slide the new CPS-5 assembly over the studs and rotor. Replace the hex nuts but do not tighten. Carefully slide the rotor back into the CPS-5 assembly. Twist the rotor while sliding to prevent damage to the assembly. Tighten hex nuts to 5 lb-ft (7 N•m).
10. Thread the wires through the wire holes in the CPS-5 and reconnect them to the transformer and terminal block as noted in Step 3.
11. Restore 120 V ac power to the actuator and connect a meter to the output.
12. Record the color and location of the feedback signal wires for re-connection later. Remove the two feedback wires. Connect a mA meter in series with a 200Ω load resistor.
13. Insert a 0.031" (.80 mm) feeler gauge between the rotor clamp and stator. Position the clamp 0.031" (.80 mm) from the stator.
14. Rotate the rotor on the control shaft until the output on the mA or voltmeter reads 50% of signal span, then tighten the clamp to 5 lb-in (.56 N•m) torque.
15. Check the feedback signal calibration as described on page 32.

MAINTENANCE Component Replacement

HANDSWITCH



WARNING

Electrical shock hazard. Disconnect power before proceeding.

REMOVE THE EXISTING HANDSWITCH:

1. Remove power from the actuator.
2. Remove the terminal cover (1/2" wrench).
3. To access the Handswitch, the terminal barrier plate must be removed on all models except the 11-1__.
4. Clip the five wires from the old Handswitch (removing any tie wraps or sleeving that may interfere).
5. Remove the Handswitch knob by loosening the two inset screws (5/64" hex wrench).
6. Remove the threaded bushing behind the Handswitch knob. The remaining Handswitch assembly components may now be removed from the terminal compartment.

INSTALL THE NEW HANDSWITCH:

7. Insert the new threaded bushing through the actuator onto the shaft, then attach the components leading to the switch as shown in the illustration below.
8. Place the seal in the bushing, then insert the knob over the bushing. Tighten the two inset screws to 3 lb-ft (4 N•m).

9. Splice the wires from the new Handswitch assembly to the wires from the actuator, color to color. Ensure the wiring is not exposed after splicing.
10. Replace the terminal cover, tightening the captive screws to 10 lb-ft (14 N•m).

NOTE: When the Handswitch is turned fully clockwise, "AUTO" should be indicated. Be sure to place the tab on the tabbed washer into the slot in the actuator body to secure the Handswitch in place.

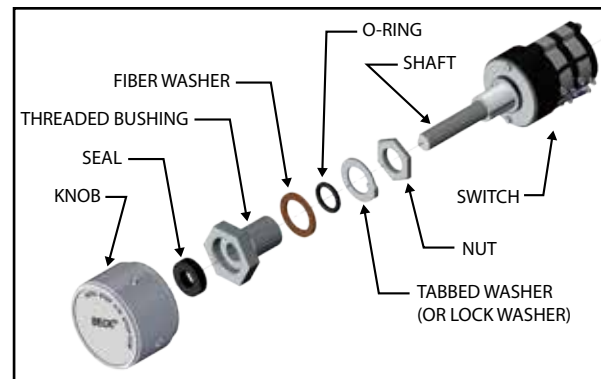

HANDSWITCH COMPONENTS

GASKETS

While performing any maintenance, inspect exposed cover gaskets for wear or damage. In order to protect internal components, worn or damaged gaskets should be replaced.

To remove, scrape all of the old adhesive and gasket material from the body housing and cover, if necessary. Replacement gaskets are self-adhering, silicone rubber. Peel the backing off the replacement gasket and carefully apply to the actuator body.

MAINTENANCE Component Detail

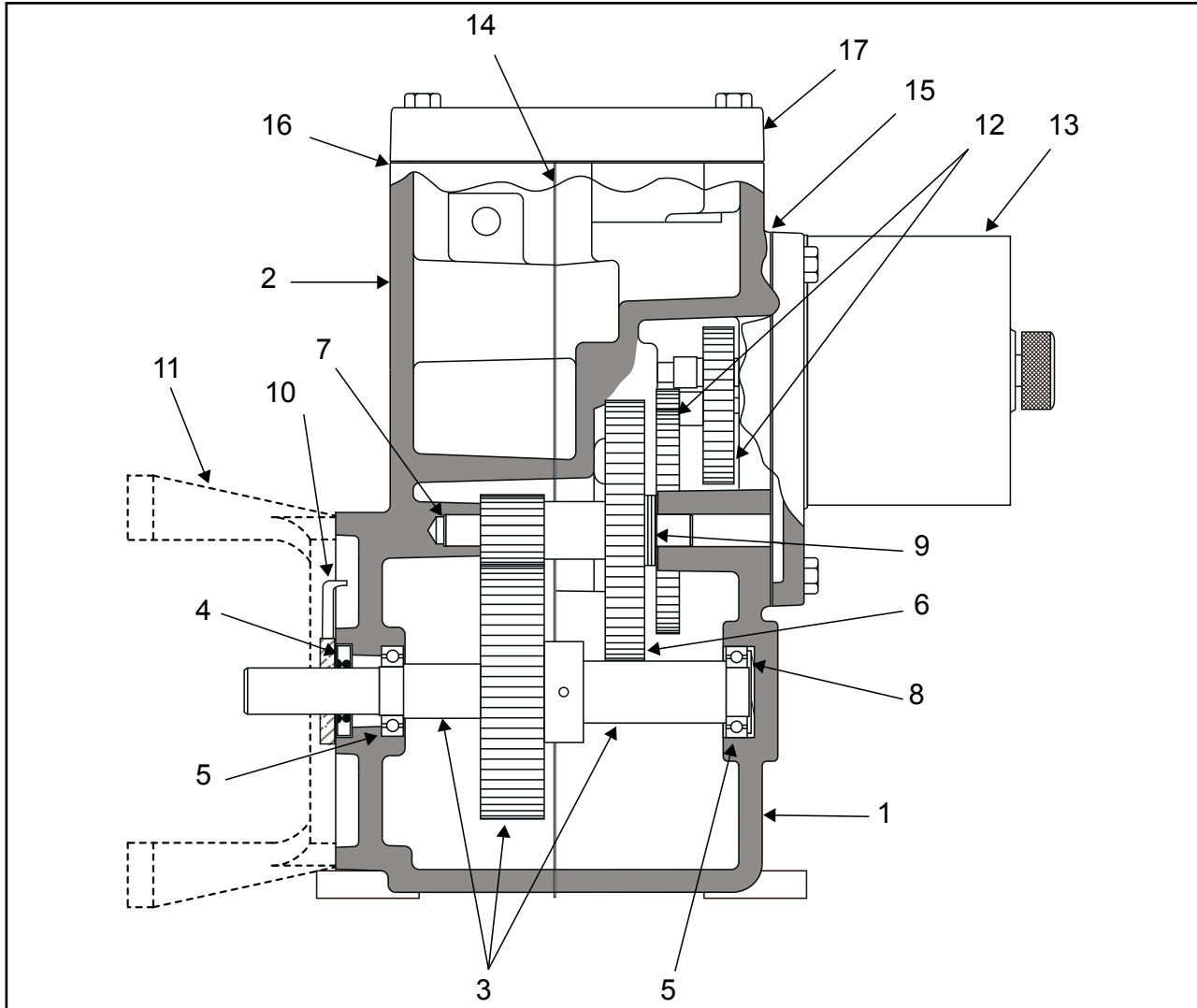

TYPICAL ACTUATOR COMPONENTS FOR MODELS 11-1_*

Item Number	Description	Part Number	Item Number	Description	Part Number
1	Body, rear	Field Replacement is not recommended	12	Gear module assembly	(see torque & timing table, page 49)
2	Body, front		13	Motor Assembly	
3	Output shaft assembly		14	Gasket, body	20-0660-83
4	Seal, output shaft		15	Gasket, motor assembly	20-0660-15
5	Ball bearing, output shaft (2)		16	Gasket, terminal cover	20-0660-16
6	Gear, 3rd combination	Contact Beck with actuator serial number for additional information	17	Terminal compartment cover	14-9744-20
7	Pin, 3rd combination gear		18	Terminal Block assembly** (23 terminals)	20-1541-01
8	Spring washer		19	Control end compartment cover**	11-0990-20
9	Thrust washer		20	Gasket, control end cover**	10-8080-02
10	Index pointer (model 11-15_ only)	10-4620-01	21	Gasket, Relay Board cover**	20-0660-17
11	Bracket (model 11-16_ only) (Note: check valve mounting specification for part number)	see note	22	Relay Board compartment cover**	13-2341-01

*Note: To ensure exact replacement parts, contact Beck with the model /serial number found on your actuator nameplate.

** Not shown in this view.

MAINTENANCE Component Detail

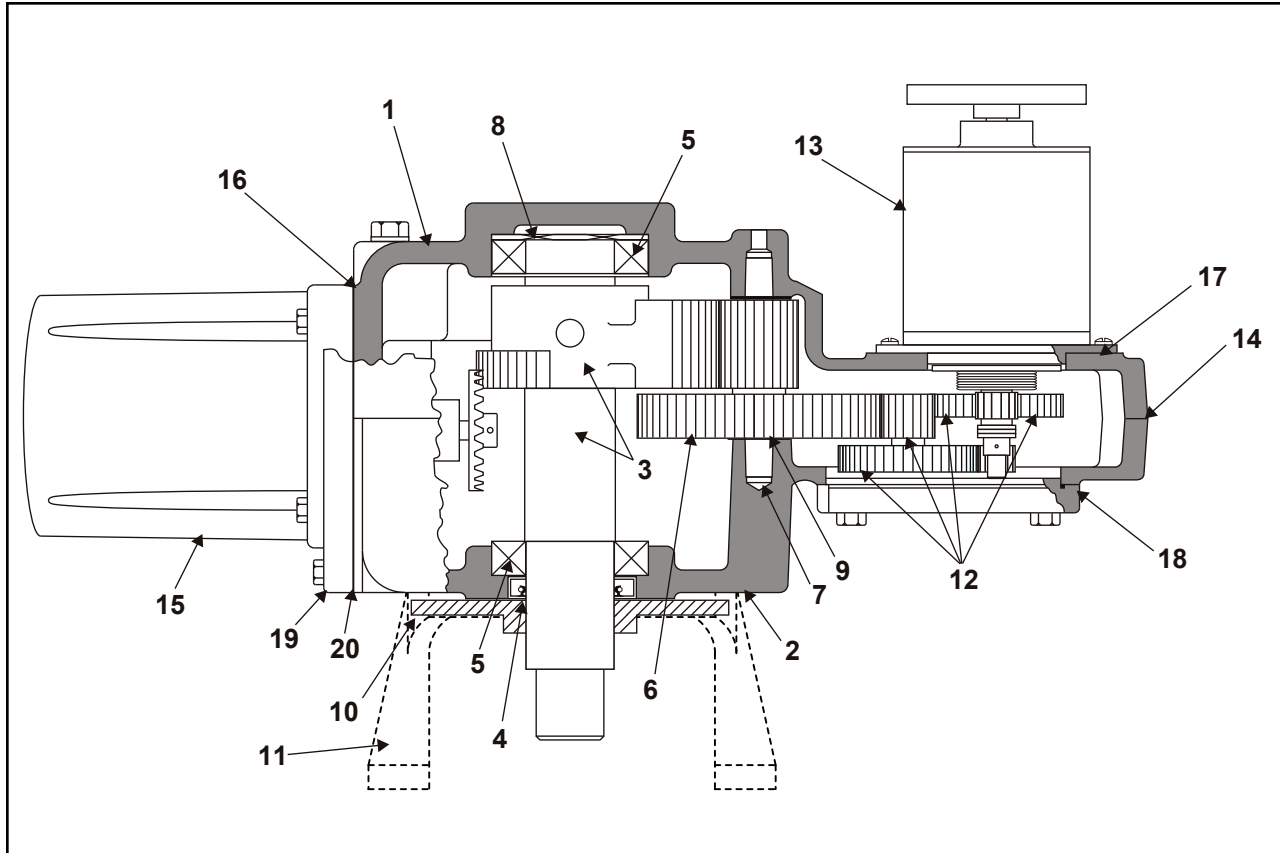

TYPICAL ACTUATOR COMPONENTS FOR MODELS 11-2_ / -3_*

Item Number	Description	Part Number	Item Number	Description	Part Number
1	Body, rear	Field Replacement is not recommended Contact Beck with actuator serial number for additional information	12	Gear module assembly	(see torque & timing table, page 49)
2	Body, front		13	Motor Assembly	
3	Output shaft assembly (11-2_)		14	Gasket, body	20-0660-06
	Output shaft assembly (11-3_)		15	Control end compartment cover	11-0990-20
4	Seal, output shaft		16	Gasket, control end cover	10-8080-02
5	Ball bearing, output shaft (2)		17	Gasket, motor assembly	20-0660-27
6	Gear, 3rd combination		18	Gasket, gear module assembly	20-0660-26
7	Pin, 3rd combination gear		19	Terminal & Relay Board compartment cover	14-9741-03
8	Spring washer		20	Gasket, Relay Board & terminal cover	20-0660-03
9	Thrust washer	21	Terminal Block assembly** (23 terminals)	20-1541-01	
10	Index (model 11-20_ / 11-30_ only)	14-9900-01	22	Barrier Plate**	20-2960-08
11	Bracket (model 11-26_ / 11-36_ only) (Note: check valve mounting specification for part number)	see note	23	Gasket, barrier plate**	20-0660-22

*Note: To ensure exact replacement parts, contact Beck with the model /serial number found on your actuator nameplate.

** Not shown in this view.

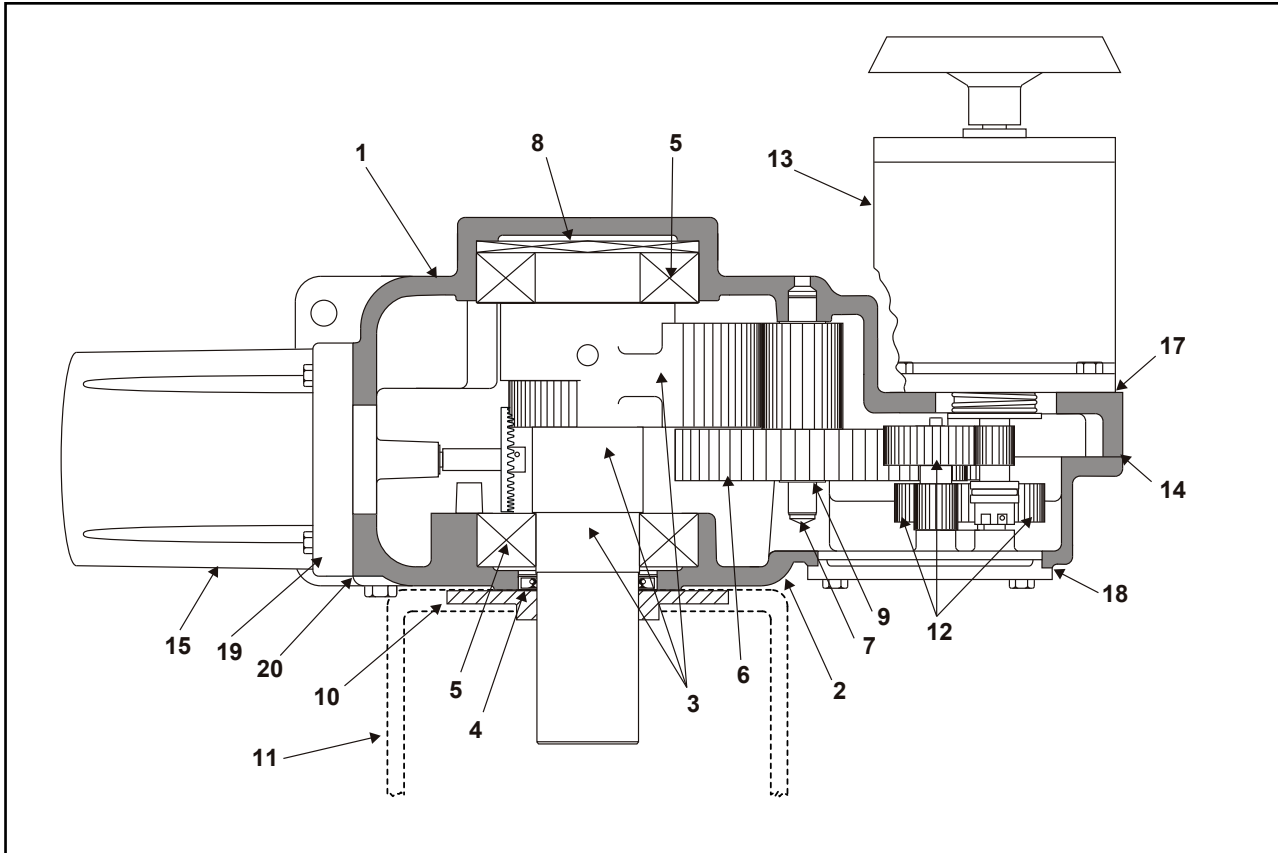

TYPICAL ACTUATOR COMPONENTS FOR MODELS 11-4_*

Item Number	Description	Part Number	Item Number	Description	Part Number
1	Body, rear	Field Replacement is not recommended	12	Gear module assembly	(see torque & timing table, page 49)
2	Body, front		13	Motor Assembly	
3	Output shaft assembly (11-4_)		14	Gasket, body	20-0660-09
4	Seal, output shaft		15	Control end compartment cover	11-0990-20
5	Ball bearing, output shaft (2)		16	Gasket, control end cover**	10-8080-02
6	Gear, 3rd combination		17	Gasket, motor assembly	20-0660-08
7	Pin, 3rd combination gear		18	Gasket, gear module assembly	20-0660-07
8	Spring washer		19	Terminal & Relay Board compartment cover	14-9741-03
9	Thrust washer		20	Gasket, Relay Board & terminal cover	20-0660-03
10	Index (model 11-40_ only)		14-9901-02	21	Terminal Block assembly** (23 terminals)
11	Bracket (model 11-46_ only) (Note: check valve mounting specification for part number)	see note	22	Barrier Plate**	20-2960-08
			23	Gasket, barrier plate**	20-0660-22

*Note: To ensure exact replacement parts, contact Beck with the model /serial number found on your actuator nameplate.

** Not shown in this view.

MAINTENANCE Spare Parts & Part Numbers

RECOMMENDED SPARE PARTS

The table below indicates the common recommended spare parts that may be utilized across many Group 11 actuator models. The Beck website (www.haroldbeck.com) provides an actuator serial number lookup tool. The tool will

display the actuator torque and timing which can be cross-referenced to a motor part number on the "Torque & Timing" table (page 49) if the part numbers are not known.

***Note that motor replacement part numbers will include the suffix "KIT"; e.g., 20-2700-20-KIT.**

COMMON RECOMMENDED SPARE PARTS

Description	Part Number
Relay board (option 5 & 6 only)	See table, p. 12
Fuse, 6A, 250V	13-2230-03
CPS-5 assembly (option 6 only)	20-4400-02
Control motor	See below
Motor resistor	See below
Motor capacitor	See below

Description	Part Number
Fuse (F1) w/ operating voltage >120 V	See page 49
Limit switch assy. (CW / CCW)	20-3202-10
Auxiliary switch assy. 2 switches (S1-S2)	20-3202-11
4 switches (S1-S4)	20-3202-12
Film potentiometer (option 5 only)	20-3060-03
Gasket kit	See below

GASKETS, MOTORS^a, RESISTORS, & CAPACITORS

Actuator Model Number	Gasket Kit Part Number	Motor					Capacitor		Resistor	
		Part Number*	Current (A at 120 Vac, 60 Hz ^c)	Torque (N·m)	RPM	Freq. (Hertz)	Part Number	Value (µf)	Part Number	Value (Ω)
11-1__	20-3110-01	20-2700-20	.17	0.5	72	60	14-2840-02	2	11-5802-03	500
						50	14-2840-13	3		500
		20-2701-20	.31	1.0	72	60	14-2840-11	4	11-5802-02	475
						50	14-2840-31	6		11-5802-06 (2 req'd)
		20-2204-20	.44	1.5	72	60	14-2840-16	5	11-5801-12 ^d	220
						50	14-2840-19	7		220
20-2204-21	.44	1.5	72	60	14-2840-16	5	11-5801-12 ^d	220		
				50	14-2840-19	7		220		
11-2__ & 11-3__	20-3110-02	20-2704-21	.43	1.5	72	60	14-2840-16	5	20-1971-13	220 ^b
						50	14-2840-19	7		220 ^b
		20-2705-21	.71	3.0	72	60	14-2840-05	8	20-1971-12	110 ^b
						50	14-2840-30	13		110 ^b
		20-2705-51	.74	3.3	120	60	14-2840-29	9	20-1971-14	68 ^b
						50	14-2840-30	13		72 ^b
11-4__	20-3110-03	20-2201-31	1.3	7.0	72	60	14-2840-17	15	20-1971-03	75 ^b
						50	14-2840-16 14-2840-17	5 15		75 ^b
		20-2201-32	2.3	14.0	72	60	14-2840-15	25	20-1971-04	37.5 ^b
						50	14-2840-05 14-2840-15	8 25		37.5 ^b
		20-2201-33	3.0	14.0	120	60	14-2840-15 14-2840-09	25 6	20-1971-06	18 ^b
						50	14-2840-15 14-2840-09	25 6		24 ^b

^aAll motors listed are rated 120 V ac regardless of operating voltages using optional transformers.

^bThis is a resistor assembly.

^c50 Hz currents do not exceed 120% of the 60 Hz levels.

^dAlternate power options (other than 120 or 240 V ac) require (2) 110Ω resistors, part no. 11-5802-05, in lieu of resistor shown.

TORQUE & TIMING LISTED BY MOTOR AND GEAR MODULE ASSEMBLY

Actuator Model No.	Motor Part No.	Motor Current (Amps at 120 Vac, 60 Hz ¹)	Gear Module Assy. No.*	Torque (lb-ft)	Timing @ 60 Hz ²	
					Models 11-15_, -2_, -3_, -4_ (sec./100°)	Models 11-16_, -26_, -36_, -46_ (sec./90°)
11-1__	20-2700-20	.17	14-9733-04	20 (27 N•m)	20	18
			14-9733-03	40 (54 N•m)	40	36
			14-9733-02	60 (81 N•m)	60	54
			14-9733-01	80 (108 N•m)	90	81
	20-2701-20	.31	14-9733-05	15 (20 N•m)	11	10
			14-9733-04	40 (54 N•m)	20	18
			14-9733-03	80 (108 N•m)	40	36
20-2204-20	.44	14-9733-03	120 (163 N•m)	40	36	
20-2204-21	.44	14-9733-07**	80 (108 N•m)	24	22	
11-2__	20-2704-21	.43	14-9730-04	125 (169 N•m)	40	36
			14-9730-05	175 (237 N•m)	60	54
			14-9730-08	250 (339 N•m)	75	68
	20-2705-21	.71	14-9730-02	125 (169 N•m)	20	18
			14-9730-04	250 (339 N•m)	40	36
20-2705-51	.74	14-9730-04	250 (339 N•m)	24	22	
11-3__	20-2704-21	.43	14-9730-09	300 (407 N•m)	100	90
	20-2705-21	.71	14-9730-04	300 (407 N•m)	40	36
			14-9730-05	400 (542 N•m)	60	54
			14-9730-08	550 (746 N•m)	75	68
			14-9730-09	650 (881 N•m)	100	90
	20-2705-51	.74	14-9730-04	300 (407 N•m)	24	22
			14-9730-05	400 (542 N•m)	36	32
			14-9730-08	550 (746 N•m)	45	41
14-9730-09			650 (881 N•m)	60	54	
11-4__	20-2201-31	1.3	14-9732-05	350 (475 N•m)	24	22
			14-9732-07	550 (746 N•m)	40	36
			14-9732-02	800 (1085 N•m)	60	54
			14-9732-04	1,000 (1356 N•m)	75	68
			14-9732-03	1,500 (2034 N•m)	100	90
	20-2201-32	2.3	14-9732-05	650 (881 N•m)	24	22
			14-9732-07	1,000 (1356 N•m)	40	36
			14-9732-02	1,800 (2440 N•m)	60	54
	20-2201-33	3.0	14-9732-07	1,000 (1356 N•m)	24	22
14-9732-02			1,800 (2440 N•m)	36	32	

CAUTION: Use only the motor and gear module combinations listed above; other combinations may cause internal damage to the actuator and/or damage to the external equipment.

¹50 Hz currents do not exceed 120% of 60 Hz levels.

²50 Hz timing = 1.2 x 60 Hz timing.

* Note that gear module replacement part numbers will include the suffix "KIT"; e.g., 14-9733-04-KIT.

** This gear module assembly is integral to the motor -- field replacement is not recommended.

TROUBLESHOOTING

If your unit contains a Stall Protection Module (SPM), refer to publication 80-0017-03, "Troubleshooting".

CONDITIONS	POSSIBLE CAUSES	CORRECTIONS
Actuator runs in only one direction in AUTO and both directions with Handswitch on CW and CCW.	Handswitch failure.	Check continuity from terminal N to V and M to U with Handswitch in AUTO position. See wiring diagram.
	Jumper between F–N or D–M (F–M or D–N) not connected.	Connect jumper.
Actuator motor oscillates in AUTO mode	Feedback potentiometer dirty.	Clean or replace potentiometer.
	Physical obstruction (e.g., valve jammed or load greatly exceeds rating of actuator).	Check operation with Handswitch and remove obstruction if present.
	Excessive wear in gear train or bearings.	Replace worn drive train parts.
Actuator motor erratic or runs in wrong direction in automatic manual operation.	Control motor winding open.	Replace control motor.
	Control motor capacitor shorted or open.	Replace capacitor.
	Control motor resistor open.	Replace resistor.
Actuator will not run either direction or one direction in automatic or manual operation.	Limit switch failure.	Replace limit switch.
	Handswitch failure.	Replace Handswitch.
Actuator runs erratic from 100° to 0° and runs normally from 0° to 100° in AUTO.	Feedback potentiometer dirty. Loss of feedback voltage drives the unit towards the 100% limit.	Clean feedback potentiometer with mild soap and water.
Actuator runs uncontrollably to some position, then oscillates.	Feedback potentiometer open.	Replace feedback potentiometer.
Actuator does not stop at normal or desired limit of shaft travel.	Limit switches adjusted incorrectly.	Readjust limit switches.
	Limit switch failure.	Replace limit switch.
	CPS-5 calibration incorrect.	Calibrate CPS-5.
Actuator drives to 100% and stays.	Handswitch left in CW / CCW position.	Return Handswitch to AUTO position.
	Potentiometer open or complete loss of contact with wiper.	Check potentiometer and replace if necessary.
	CPS-5 feedback out of phase with control motor.	Restore proper phasing of CPS-5 feedback with control motor.
	Jumper between terminal F–N (F–M) not connected.	Connect jumper.
Actuator travel very non-linear: •Response normal from zero to mid-range, then runs to 100%.	CCW / CW limit switch failure.	Replace limit switch.
	CPS-5 power supply failure.	Check CPS-5 power supply voltage. See below.
CPS-5 LED goes out during normal travel.	CPS-5 not correctly calibrated.	Calibrate CPS-5.
Potentiometer or CPS-5 output decreases when it should increase.	CPS-5 rotor position not set for proper rotation. End connections on potentiometer reversed.	Reset CPS-5 rotor position. Calibrate potentiometer.
CPS-5 output non-linear.	CPS-5 rotor position not set properly. CPS-5 zero potentiometer improperly adjusted.	Reset CPS-5 rotor position. Contact factory.
CPS-5 output does not reach maximum signal, but low end calibration is correct.	Output is overloaded: •load resistance is too low for voltage range. •load resistance is too high for current range.	Check load resistance against suggested feedback signal terminal hook-up.
	Low voltage: •CPS-5 power failure.	Check line voltage at CPS-5 transformer terminals 1 and 3. Check CPS-5 voltage at resistor. Check CPS-5 power supply voltage across capacitors C8 (13 V, except -05.15 V), C9 (15 V), C10 and C11 (28 V).
	CPS-5 rotor not properly set. CPS-5 zero potentiometer not properly adjusted.	Reset CPS-5 rotor position. Refer to factory.
CPS-5 signal will not calibrate down to 4 mA.	Not enough load on meter circuit. Unit calibrated for less than 80° rotation.	Connect 200Ω resistor in series with meter. Remove R8.
Actuator does not stay in place with power off.	SLM friction surface worn.	Replace control motor.
Control motor runs, but output shaft does not move in one or both directions.	SLM failure.	Replace control motor.
Actuator equipped with modulating option 5 or 6 and an optional relay board does not run reliably in one or both directions while in AUTO.	Controller output requires a greater holding current than the relay board draws.	Check the controller output required AC holding current. If greater than 10 mA, additional load must be provided.

APPENDIX CPS-5 Functional Block Diagrams

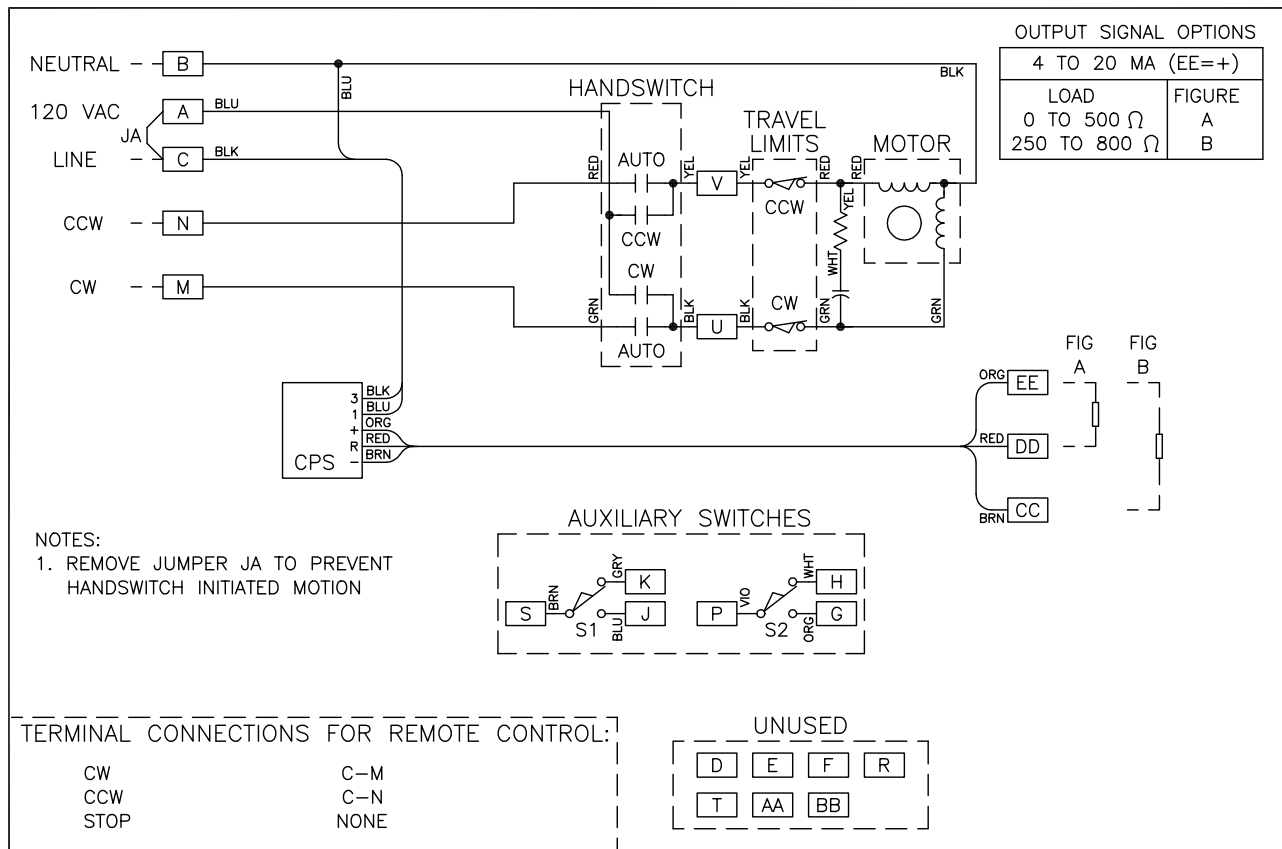
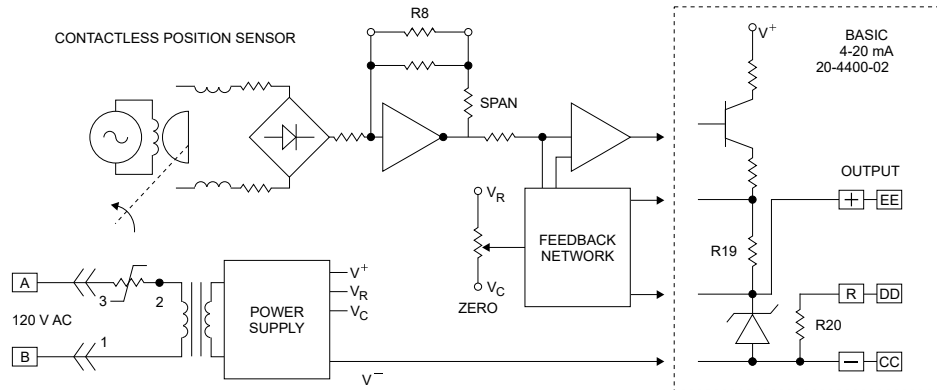

Typical Schematic for Control Option 6

APPENDIX CPS-5 Data

CPS-5 SYSTEM APPLICATION DATA SUMMARY

FEEDBACK SIGNAL OPTIONS	CPS-5 MODEL NO.	EXTERNAL LOAD RESISTANCE	COMPATIBLE CONTROL SYSTEMS
Current Signal			
4 to 20 mA	20-4400-02	800Ω (Max.)	Industry Std (ISA)

CPS-5 SIGNAL OUTPUT TERMINAL CONNECTIONS AND LOADING

SIGNAL RANGE	OUTPUT TERMINALS (+) (-)	RANGING RESISTOR		RESISTOR CONNECTIONS	MAXIMUM EXTERNAL LOAD
		VALUE	BECK PART NO.		
Models 20-4400-02					
4 to 20 mA	EE—CC	Open			800Ω
4 to 20 mA	EE—DD	Open			500Ω

APPENDIX *Optional LED Display*

The optional LED display board (p/n 22-5008-51) for open/close and AC-pulsed Beck actuators (Control option 3 through 6) provides lighted color indication of the actuator output position. The board resides in the same location (the electronics compartment) as that of the optional DCM display board available with 4–20 mA modulating actuators (control option 9). The same compartment cover with a tempered glass window is used with all versions.

This display board includes a red, green and yellow LED to indicate the actuator output position. The lights are driven by 120 V ac actuator power and are energized using the actuator's internal auxiliary switches.

The red and green LEDs, which are intended to indicate OPEN and CLOSE ends-of-travel are easily setup by connecting jumpers on the actuator's terminal block (see the wiring diagram below).

The yellow LED will light whenever both the red or green LED are not lit (when the actuator is not at either end-of-travel limit). If desired, the yellow LED may be turned off with a slide switch located on the board (see image below).

The red LED will light when the output shaft has rotated to the CCW travel limit, and the green LED will light after rotation to the CW travel limit (default setting). To reverse these LEDs (red = CW, green = CCW), a toggle switch is located on the board (see image below).

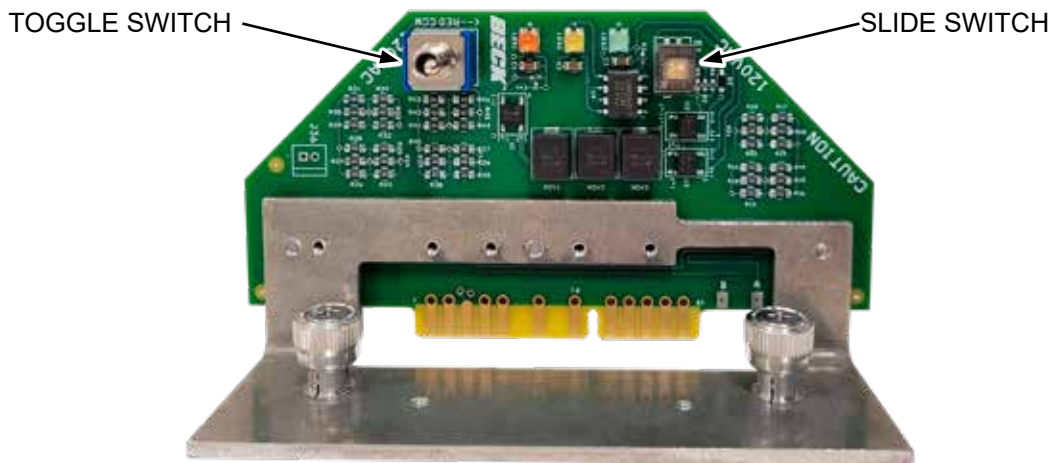

OPTIONAL LED DISPLAY BOARD

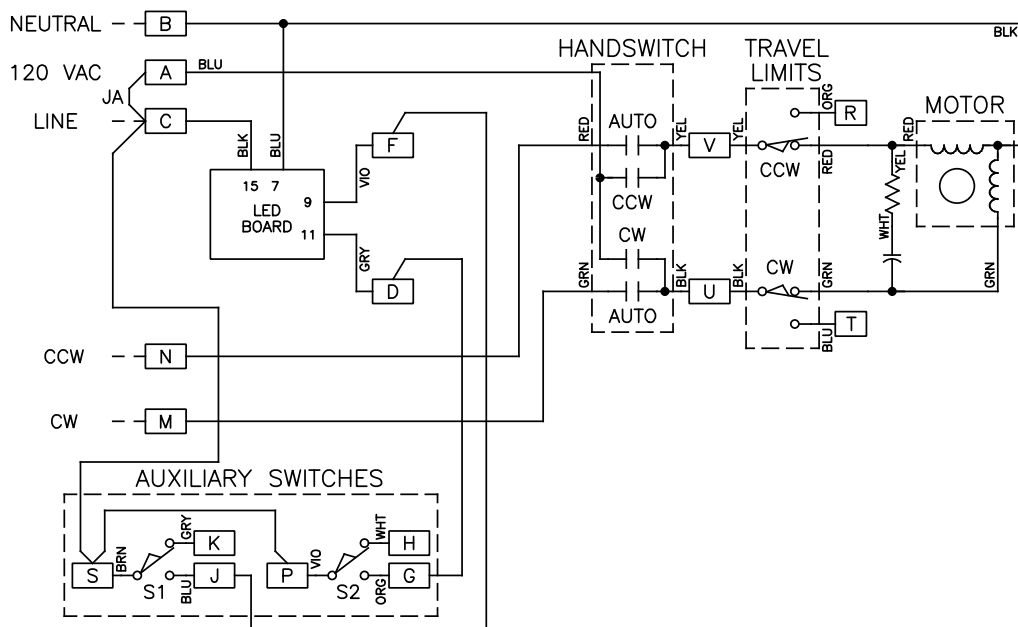

TYPICAL WIRING DIAGRAM WITH TWO AUXILIARY SWITCHES

INDEX

Appendices	51–53	Maintenance	36–49
CPS-5 Functional Block Diagrams	51	Component Detail	45–47
CPS-5 Data	52	Component Replacement	37–44
Optional LED Display	53	CPS-5	51–52
Application Reviews	55	Gaskets	44, 48
Auxiliary Limit Switches	29, 41	Handswitch	44
Setting Switches	29	Lubrication/Gearing	36
Component Detail	45–47	Motor Assembly	37, 48–49
Component Location	14	Motor Capacitor & Resistor Network	37
Component Replacement	37–44	Over-travel Limit & Auxiliary Switches	48
Calibration	27–35	Routine	43
Demand Signal	35	SLM	38–40
Direction Change	30–31	Spare Parts, Recommended	48
Feedback Signal	32–34	Operation	25–26
Switches	28–29	Outline Dimension Drawings	6–11
Contactless Position Sensor		Power Quality	20
(CPS-5)	26, 32–34, 43	Precautionary Information	13
Control Options, Summary	12	Product Demonstrations	55
Demand Calibration	35	Relay Board	42
Demand Signal	35	Self-Locking Mechanism (SLM)	25, 38–40
Direction of Output Shaft Rotation	30–31	Services	55
Feedback Signal	32–34	Site Surveys	55
General Specifications	4–5	Spare Parts, Recommended	48
Handswitch	25, 44	Specification Writing	55
Handwheel	25	Stall Protection and Annunciation, Optional	4
How to Obtain Service	55	Start-up	24
Installation	15–23	Storage Information	13
Direct-Mount	15	Table of Contents	3
Electrical	20	Torque and Timing	49
Linkage-connected	16–19	Travel	30
Link-Assist™	16	Change Travel	30–31
Mechanical	15–19	Troubleshooting	50
Valves	15	Warranty Statement	55
Wiring	21–23		
Introduction	2		
Limit Switches (Over-travel)	28, 41		
Setting Switches	29		
Linkage Kits	17–18		

SERVICES

PRODUCT DEMONSTRATIONS

Each of Beck's Sales Engineers has access to a complete set of actuator models so that he can demonstrate virtually any of their features at your location. In order to arrange to see a Beck actuator in your plant or office, contact Beck's Sales Department.

SITE SURVEYS

Beck Sales Engineers are available to discuss your process control requirements. Often a visit to your location is the best way to gain a thorough understanding of your needs, in order to meet them most accurately and completely.

Mounting hardware, torque requirements, linkage, control signal information, and optional equipment can be analyzed most effectively at the work site. Beck's analysis at the job site can help ensure that specifications are accurate, especially in the case of complex applications.

APPLICATION REVIEWS

By sharing your needs with a Beck Sales Engineer you can take advantage of the best application advice for the type of control you need.

This review will yield a better understanding of the versatility of Beck actuators for your installations, as well as complete details on options and accessories to make the process as effective as possible.

SPECIFICATION WRITING

Beck provides specification writing assistance in order to help you specify and order the right actuators for your applications. Beck Sales Engineers will work with you to make it easier for you to obtain the proper equipment and give you confidence that no details are overlooked.

HOW TO OBTAIN SERVICE

Factory repair of actuators or subassemblies is available for both normal and emergency service. To assure prompt processing, contact the factory to receive a Returned Material Authorization (RMA) number. If a repair estimation is desired, please send the name and phone number of your contact for service authorization. It is helpful to include a description of the work desired with the shipment or, in the event of a problem, the malfunction being experienced.

THREE YEAR LIMITED EQUIPMENT WARRANTY

Beck warrants to Buyer that: (i) for a period of 3 years from the date of shipment, the Equipment manufactured by Beck shall materially conform to Beck's published standard specifications in effect as of the date of shipment; and (ii) the Beck Equipment will be free from defects in materials and workmanship. This warranty does not apply to normal wear and tear, or where Beck Equipment failure is a result of improper installation, improper storage, misuse or improper maintenance, or water ingress related to Buyer or its agents failing to apply the stated torque requirements to fasteners when attaching covers or failing to replace temporary conduit plugs as stated in the installation instructions, or entry through conduits.

During the Limited Warranty Period, Buyer shall notify Beck of any alleged warranty claim within 30 days from the date Buyer discovers, or upon reasonable inspection should have discovered, such alleged claim (but in any event prior to the end of the Limited Warranty Period), and Buyer shall return the Beck Equipment in question, at Buyer's expense, to Beck for evaluation, in compliance with the terms stated in the "Return of Equipment" article in the Sales Contract. If Beck determines that the Beck Equipment fails to conform to the limited warranty, then, at Beck's sole discretion and its expense (subject to Buyer's conformity with the warranty), Beck will either: (i) repair or replace the Beck Equipment, without charge, at Beck's factory, or (ii) refund the purchase price of such Beck Equipment, less any applicable discounts, rebates, or credits. In no event will Beck's liability exceed the contract price actually paid for such Beck Equipment subject to a warranty claim. Beck makes no warranty, express or implied, with respect to any Buyout Item. This limited warranty is not transferable or assignable to any transferees of the Beck Equipment.

THIS WARRANTY IS EXPRESSLY IN LIEU OF ANY OTHER EXPRESS OR IMPLIED WARRANTY, INCLUDING IMPLIED WARRANTIES OF MERCHANTABILITY AND FITNESS FOR A PARTICULAR PURPOSE, AND ALL OTHER OBLIGATIONS OR LIABILITIES OF BECK. BUYER ACKNOWLEDGES THAT: (i) BECK HAS MADE NO INDEPENDENT INVESTIGATION OF THE SUITABILITY OF THE EQUIPMENT FOR BUYER'S INTENDED USE OR EXISTING SYSTEMS; AND (ii) BUYER HAS NOT RELIED UPON ANY REPRESENTATION OR WARRANTY MADE BY BECK OR ANY OTHER PERSON ON BECK'S BEHALF, EXCEPT AS SPECIFICALLY PROVIDED IN THE SALES CONTRACT. THIS SECTION SETS FORTH BUYER'S SOLE AND EXCLUSIVE REMEDY FOR ANY BREACH OF THE LIMITED WARRANTY SET FORTH IN THIS SECTION.

A 100% EMPLOYEE OWNED COMPANY

BECK

~ founded 1936 ~

SINCE 2021



HAROLD BECK & SONS, INC.

11 TERRY DRIVE • NEWTOWN, PENNSYLVANIA 18940 • USA

PHONE: 215-968-4600 • FAX: 215-860-6383 • E-MAIL: sales@haroldbeck.com

www.haroldbeck.com

Made in USA

