



INSTRUCTION MANUAL



For actuators manufactured
after March 2025.



INTRODUCTION

This manual contains the information needed to install, operate, and maintain the Beck 11-430 Electronic Actuator, manufactured by Harold Beck & Sons, Inc.

The 11-430 is a high torque electric actuator designed to provide precise position control of multiple burner tilt arrays, dampers, and other devices requiring up to 5,200 lb-ft (7 046 N•m) of actuator torque. The 11-430 consists of a Beck 11-400 actuator connected to a large gear reduction unit that increases the output torque of the 11-400 by a factor of 3:1.



NOTICE: This manual includes information that will make installation simple, efficient, and trouble-free. Please read and understand the appropriate sections in this manual before attempting to install or operate the Model 11-430 actuator.

TABLE OF CONTENTS

Introduction	2
Product Description	4
General Specifications	6
Outline Diminsion Drawings	8
Control Options	10
Installation	11
Demand Signal Wiring	13
Feedback Signal Wiring	15
Start-up	16
Operation	18
Calibration	21
Switches.....	21
Direction Change	23
Feedback Signal	25
Demand Signal.....	28
Maintenance	30
Routine.....	30
Component Replacement	31
Troubleshooting	35
Appendix	37
Spare Parts	37
Control Assembly	38
CPS-5 Data.....	39
CPS-5 Functional Block Diagram.....	40
Optional LED Display	41
Index	42
Services	43

PRODUCT DESCRIPTION

The Beck 11-430 actuator is engineered for precise, reliable operation of dampers and multiple burner tilt arrays. The cool, stable operation of Beck's control motors coupled with the powerful gear train provide the tight, responsive control required by modern control loops to optimize output while keeping operating costs low.

The unique all spur gear construction used in the Beck actuator is designed for long term durability. The gear train can withstand accidental stalls of up to four days without failure, and will resume instant response immediately upon removal of the condition (see page 20 for Stall Protection information). Mechanical stops in the gear train prevent over-travel.

An easy-to-turn, spoke-free Handwheel is incorporated into the 11-430 design to allow manual operation during installation or power outages. The Handwheel can be used to move a driven shaft to any position smoothly and easily under full load conditions.

The driven shaft may also be operated at its individual location by utilizing the actuator's built-in electric Handswitch.

The heavy-duty crank arm of the 11-430 actuator can be field-adjusted to travel anywhere in the 360° range.

Beck's CPS-5 Contactless Position Sensor provides accurate position feedback in demanding environmental conditions, with no contacting or wiping surfaces to wear or intermittently lose contact. The CPS-5 provides infinite resolution with linearity error of less than $\pm 1\%$ of span over the actuator's full travel.

The Beck 11-430 actuator is designed with individual weatherproof enclosures to protect the main components. The cutaway illustration below shows the basic features of the 11-400 as well as their locations.

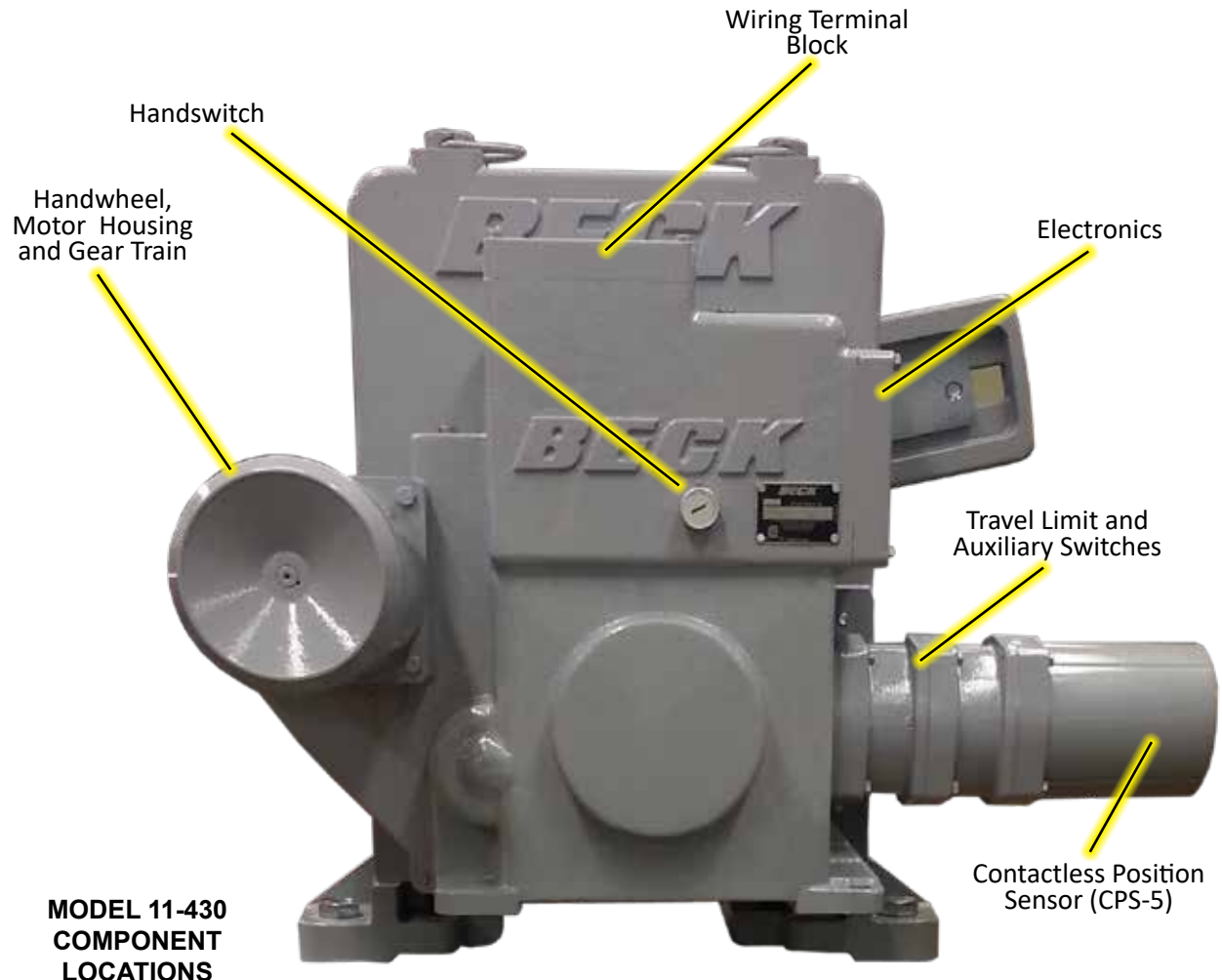

BECK LINKAGE KITS

Beck pipe linkage kits are available for completing the mechanical connection from the actuator crank arm to the load. Through the use of standardized selection, the linkage can be ordered even if the exact length is not determined until the actuator and driven device are installed.

All Beck 11-430 actuators are furnished with a crank arm and rod end (see pages 8 and 9 for dimensions). All rod ends furnished by Beck incorporate bearings to accommodate some lateral misalignment. Once the connection is made, linkage kits can be adjusted $\pm 1 \frac{1}{2}$ " (38 mm) without removal of the crank arm or load lever, making final mechanical calibration simple.

See page 16 for linkage requirements.



GENERAL SPECIFICATIONS

Actuator Power	120 V ac, single-phase, 60 Hz (standard), 50 Hz (optional) 208, 240, 380, 415, 480 & 575 V ac, 50 or 60 Hz (optional)	Allowable Tolerance: +10% - 15%						
Max. Current (Amps) by Supply Voltage (V ac)								
		Voltage						
Model	Power (VA)	120	208	240	380	415	480	575
11-430	400	3.1	1.8	1.6	.98	.89	.78	.65
Operating Conditions	-40 to 185°F. (-40 to 85°C.) 0 to 100% relative humidity, non-condensing							
Direct AC Control	120 V ac for 2-position, multi-position or modulating V ac control							
Feedback Signal with Contactless Position Sensor (CPS-5)	4–20 mA							
Output Stability	0.25% of span from 102 to 132 V ac ±0.03%/°C. of span for 0 to 50°C. ±0.05%/°C. of span for -40 to 85°C.							
Linearity	±1% of span, max. independent error							
Hysteresis	0.25% of span at any point							
Isolation	Max. leakage of 10 µA at 60 V rms, 60 Hz from output to ground							
Film Potentiometer	1,000 ohms							
Max. Voltage	40 V							
Wattage	2 W max.							
Linearity	±0.5%							
Max. Wiper Current	1 mA							
Action on Loss of Power	Stays in place							
Stall Protection and Annunciation (Optional)	If the motor tries to run in one direction for more than 300 seconds, the Stall Protection Module will shut off power to the motor and a relay contact will change state. The relay is rated for 120 V ac or dc, 10 VA. For more information, see Beck publication 80-0017-03.							
Limit Switches	Two SPDT, one for CW and one for CCW limit of travel (rated 6A, 120 V ac; .5A, 125 V dc; .25A, 250 V dc). Actuators having position sensing capability (Options 5 and 6), have over-travel limit switches set 1/2° outside the CW and CCW travel range (typically, -0.5° and 100.5°). Actuators without position sensing (Options 3 and 4), have end-of-travel limit switches set at the CW and CCW travel range (typically, 0° and 100°).							
Auxiliary Switches	Up to four switches available (rated 6A, 120 V ac; .5A, 125 V dc; .25A, 250 V dc). Switches are labeled S1 to S4 and are cam-operated, field-adjustable. S1 and S4 are set to operate just before reaching CCW travel limit. S2 and S3 are set to operate just before reaching CW travel limit.							
Handswitch	Permits local electrical operation, independent of controller signal. Standard on all units. An auxiliary contact is available as an option for remote auto indication (rated 2.5A, 120 V ac; 2.0A, 28 V dc).							



Handwheel	Provides manual operation without electrical power.
Motor	120 V ac, single-phase, no-burnout, non-coasting motor has instant magnetic braking. Requires no contacts or moving parts. Can remain stalled for approximately four days (cumulative) without damaging the gear train.
Gear Train	High-efficiency, precision-cut, heat-treated alloy steel and ductile iron spur gears. Interchangeable gear modules permit field change of timing.
Mechanical Stops	Prevent over-travel during automatic or manual operation.
Enclosures	
11-400 Drive	Type 4X, precision-machined aluminum alloy castings painted with corrosion-resistant polyurethane paint, provide a rugged, dust-tight, weatherproof enclosure.
Gear Reduction Unit	Precision-machined aluminum alloy casting painted with corrosion-resistant polyurethane paint, provides a rugged, dust-tight, weatherproof enclosure.
Standards**	CSA Labeled (US & Canada); CE Compliant; UKCA Compliant

**NOTE: May not be available with all options and models. For more information, please call Beck at 215-968-4600.

ORIENTATION B

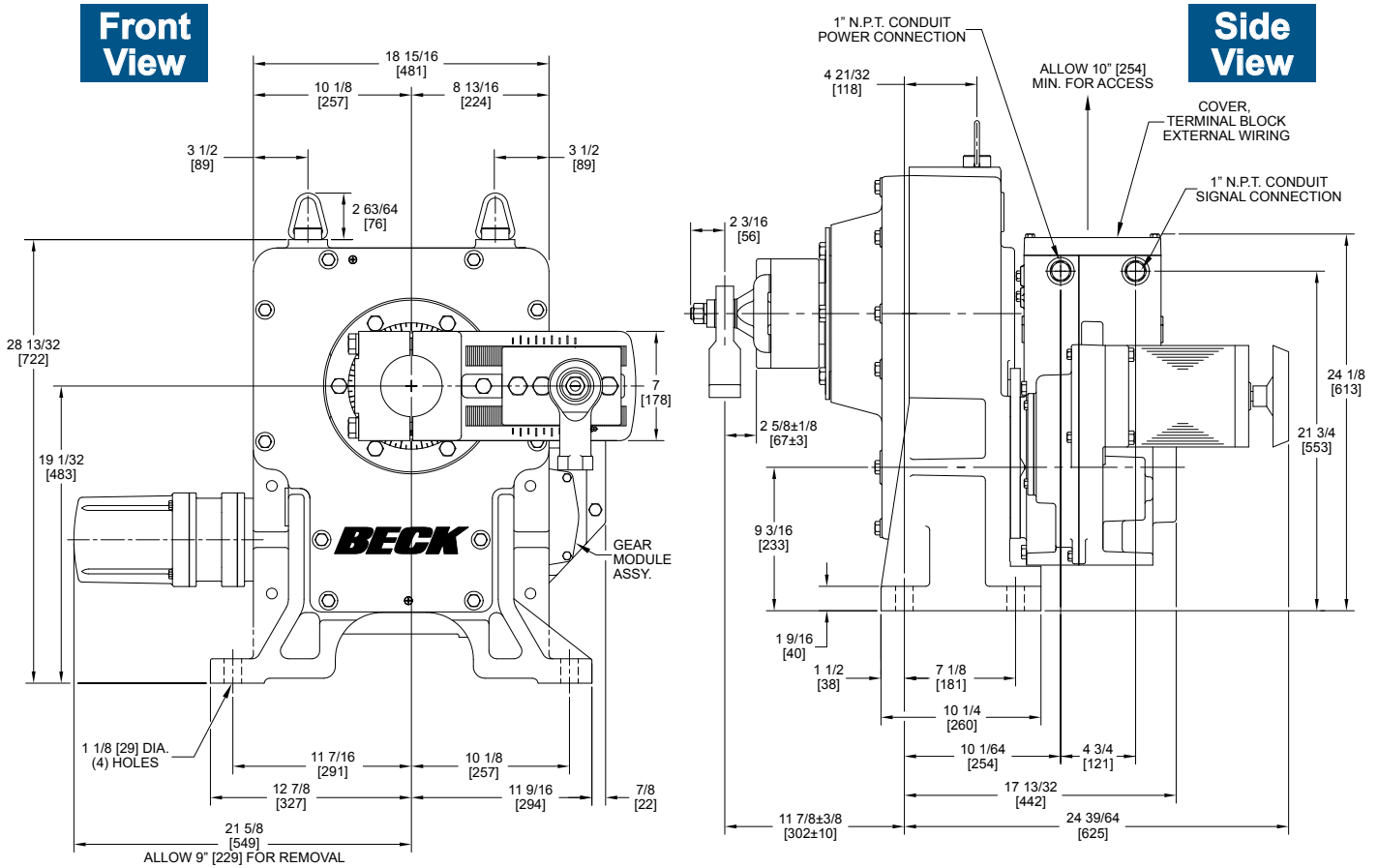

AVAILABLE CRANK ARMS (WITH ROD END)

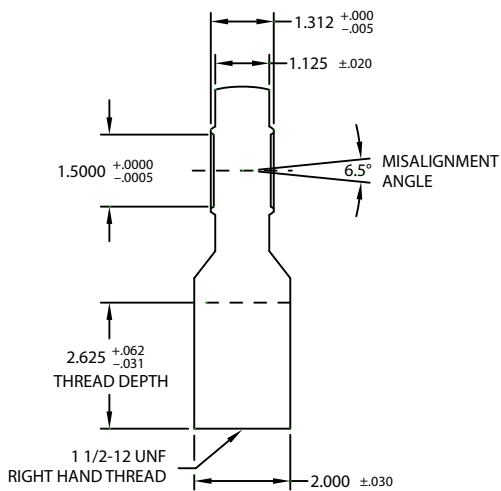

ROD END DETAIL

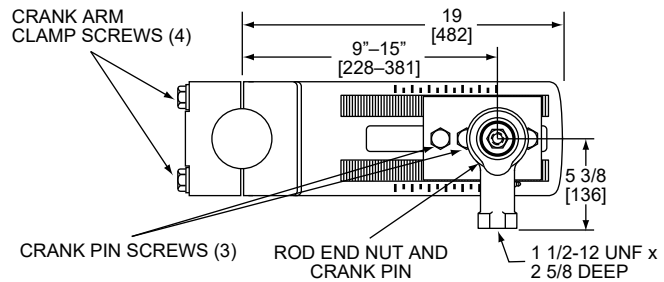

CRANK ARM, p/n 14-8022-44-KIT (default)

Others available (also with 9"-15" adjustable radius):

14-8022-73-KIT (stainless steel rod end)

14-8022-45-KIT (1 1/4-12 UNF rod end)

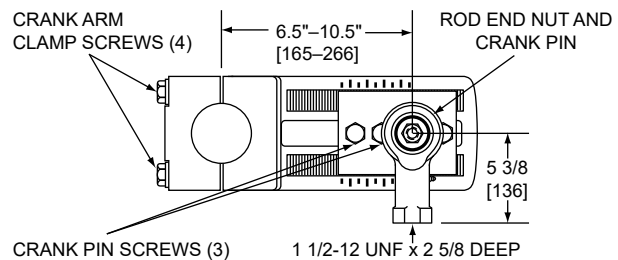

CRANK ARM, p/n 14-8022-42-KIT

CONTROL OPTIONS

**TABLE 1:
SUMMARY OF CONTROL OPTIONS**

MODEL NO.	CONTROL TYPE	INPUT SIGNAL	RELAY BOARD PART NO.	FEEDBACK DEVICE	EXTERNAL OUTPUT SIGNAL	CPS-5 PART NO.*	AUXILIARY SWITCH OPTIONS
11-436	Direct AC Control (Modulating)	120 V ac	None	CPS-5 Contactless Position Sensor (without Monitor)	4–20 mA	20-4400-02	None 2 4
		Low Power 120 V ac	13-2246-50				
		Low Power dc	13-2246-51				
11-435	Direct AC Control (Modulating)	120 V ac	None	1000 ohm Potentiometer 20-3060-03	1000 ohm Pot.	n/a	None 2 4
		Low Power 120 V ac	13-2246-50				
		Low Power dc	13-2246-51				
11-434	5 Position	120 V ac	n/a	None	None	n/a	None 2
	4 Position						
	3 Position						
11-433	2 Position Open/Close	120 V ac	n/a	None	None	n/a	None 2 4

*CPS-5 20-4400-02 boards 20-3400-02 boards.

INSTALLATION

SAFETY PRECAUTIONS



WARNING

Installation and service instructions are for use by qualified personnel only. To avoid injury and electric shock, do not perform any servicing other than that contained in this manual. Please read and understand the appropriate sections in this manual before attempting to install or operate your drive.

STORAGE INFORMATION

The 11-430 should be stored in its shipping crate in a clean, dry area where the temperature is between -40° and 85°C (-40° to 185°F).

If it is necessary to store the actuator outdoors for a long period of time, it should be stored above ground and covered with a waterproof cover. Do not stack 11-430 crates on top of one another. Stored drives should be checked periodically to make sure no condensation has formed in the electronic and terminal compartments. Damage due to moisture while in storage is not covered by warranty.

UNPACKING

The actuator is shipped in a slatted wooden crate. The crate is braced internally at the top and sides of the actuator. To unpack, remove the top of the crate first. Then remove the sides of the slatted crate, carefully removing the support braces. After unpacking, the skid may be used to transport the actuator to the installation site.

Orientation Option A (Page 8)

The 11-430, orientation option A, is bolted to a removable wooden pedestal with four $3/4$ " hex head bolts. These bolts are not to be used for mounting the actuator to its final mounting platform. The pedestal provides a mounting base for the actuator and also protects the 11-400 control motor. Do not remove the actuator from the pedestal or the protective cover from the motor until the actuator is ready to be placed on its final mounting platform. The pedestal is attached to the wooden shipping skid with metal banding.

Orientation Option B (Page 9)

The 11-430, orientation option B, is bolted directly to the wooden shipping skid. These bolts are not to be used for mounting the actuator to its final mounting platform. Do not remove the actuator from the skid or the protective cover from the motor until the actuator is ready to be placed on its final mounting platform.

MOUNTING INSTRUCTIONS

The Beck 11-430 can be installed in any convenient orientation because the gear train does not require an oil bath. Refer to the outline dimension drawing for physical dimensions and required clearances.

The 11-430 must be bolted firmly to a mounting surface which will not yield to the stresses created from operating the device. Use 1" diameter grade 5 bolts and torque to 480 lb-ft. A flat, rigid, vibration-free surface will generally prolong the life of the actuator's components. Place shims under the feet of the actuator to correct for any unevenness in the mounting surface before the mounting bolts are tightened.

The output shaft of the actuator should be parallel to the driven shaft, and the linkage should be perpendicular to the plane of the two shafts. Small misalignments can be tolerated if a rod end fitting is used on the driven lever similar to that provided on the Beck crank arm.

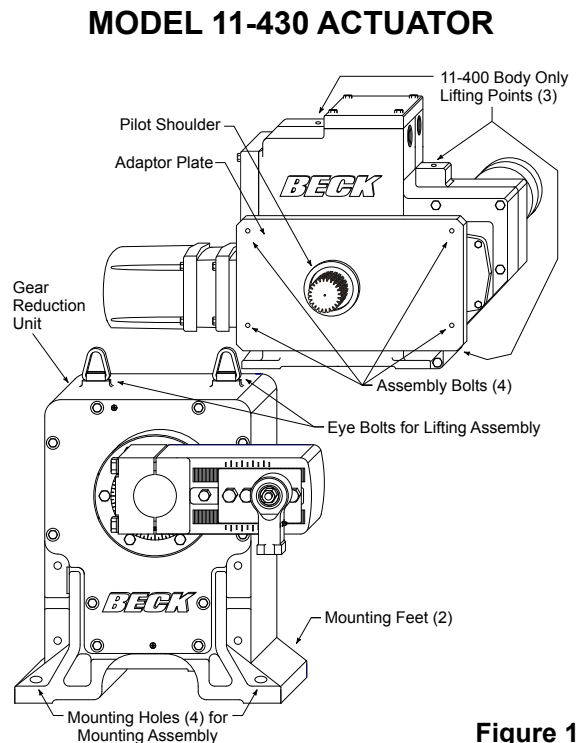

Figure 1

INSTALLATION

ORIENTATION OPTIONS

The 11-400 can be assembled to the 11-430 gear reduction unit in two different positions. These are shown as Orientation Options A and B in the outline dimension drawings on pages 8 and 9. The choice of orientation option depends on the installation and the need to access the wiring and electrical adjustments of the 11-400 actuator. Normally the orientation option is selected at the time of order and factory-assembled to that specification. The orientation option can be changed. Caution: Consult the factory before attempting to change the actuator orientation.

INSTALLATION—ELECTRICAL

NOTE: All Beck actuators are shipped from the factory ready for installation; no electrical adjustments are required before placing them in operation. Each actuator is set up and calibrated to the customer's specifications that were written into the equipment order.

Two N.P.T. conduit connections are provided. Temporary plugs are installed in the conduit entrances at the factory for shipping only and are not intended for permanent use.

The 1/2" conduit is for signal wiring connections, and the 1" conduit is for power and auxiliary switch connections. Conduit entries should be routed from below the actuator so that condensation and other contaminants flow away from the conduit. Prior to actuator operation, all conduit entrances must be properly sealed in accordance with National Standards or Regulatory Authorities.

A large, clearly labeled terminal block on the top of the actuator is enclosed in a separate, gasketed, metal enclosure. Terminals will accommodate up to 12 AWG wiring (see page 4 for location of the terminal block).



CAUTION

Always close covers immediately after installation or service to prevent moisture or other foreign matter from entering the actuator.

Refer to the wiring diagram furnished with your Beck actuator for proper AC power and signal connections. It is advisable to provide normal short circuit protection on the AC power line. A copy of the wiring diagram is shipped with each actuator and is fastened to the inside of the terminal block cover. If there is no wiring diagram available, you may obtain a copy from Beck by providing the serial number of your actuator.

Your Beck actuator has been supplied to match the signal source in your control loop.

For maximum safety, the Beck actuator body should be grounded. Use the grounding terminal provided in the actuator body.

TERMINAL SCREW TORQUES

Each terminal screw should be torqued to the proper specification upon landing the wire.

Terminals	Torque	
	(lb-in)	(N•m)
A-V	16	1.8
AA-EE	12	1.4
FF-SS*	9	1.0
1-3*	20	2.3

* Terminals included only with certain optional features.

INSTALLATION Demand Signal Wiring

The terminal block is located in a separate, gasketed compartment at the top of the actuator. Line voltage connections are made on terminal designations A through V and are oriented at a right angle from the low voltage signaling terminals designated AA through EE.

Actuators equipped with optional transformers to accommodate popular voltages include an additional terminal strip and fuse for power wiring (with the exception of the 240 volt option). See optional transformer wiring connections below.

Terminal screws will accept standard spade or ring terminals. Terminals A through V are size #8, and terminals AA through EE are size #6. Optional transformer terminal screws (designated 1, 2, & 3) are size #10. For wiring versatility, the screw-down clamp design will also accept unterminated wire. All terminals will accept up to #12 AWG (3.31 mm²), with up to #10 AWG wire acceptable for optional transformer terminals (1-3).

Typical wiring connections are shown below. See the wiring diagram on the inside of the terminal cover for specific wiring connections. Each actuator can be ordered with up to four optional auxiliary switches (wiring connections are described in the Configuration/Calibration section).

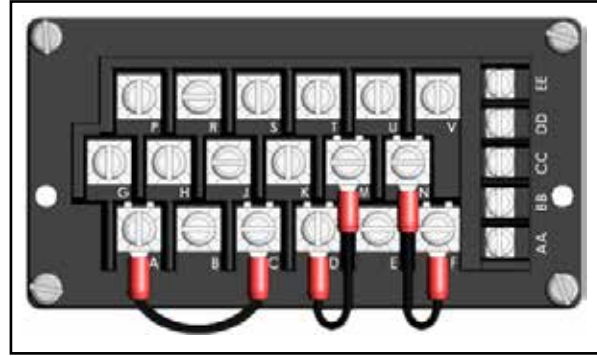

CAUTION
AC power to the actuator must be turned off before removing the jumper.

Three additional terminals and fuse (F1) are provided with 3-phase power options.



FUSE (F1) 1 2 3

Option 6, Modulating

Direct AC Control with Contactless Position Sensing

Customer must supply three wires to directly control the actuator motor direction: One 120 V ac line to run CW (terminal M), one 120 V ac line to run CCW (terminal N), and one neutral (terminal B). Customer may supply two additional wires to monitor the analog position feedback signal (see page 15 for connections). If position feedback monitoring is desired, a 120 V ac line must be connected to terminal C. The actuator's feedback circuit power supply is derived from this 120 V ac line, therefore the feedback signal must be wired to a "4-wire" type, non-powered analog input.

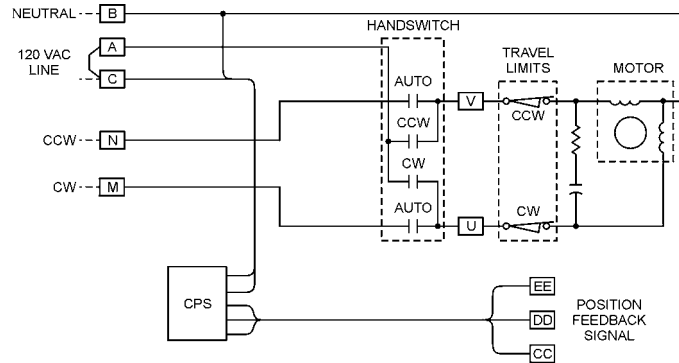

CONNECTIONS FOR ALTERNATE POWER OPTIONS

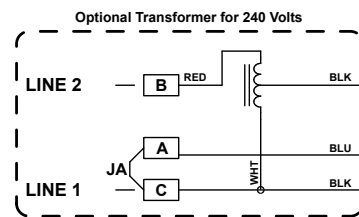
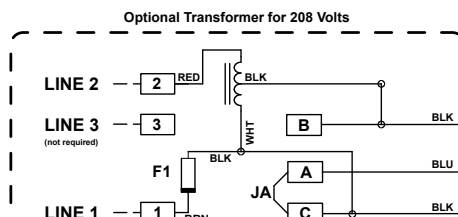
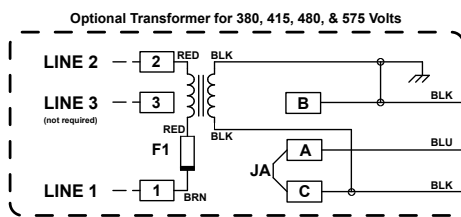

INSTALLATION Demand Signal Wiring

Option 5, Modulating

Direct AC Control with Potentiometer Position Sensing

Customer must supply three wires to directly control the actuator motor direction: One 120 V ac line to run CW (terminal M), one 120 V ac line to run CCW (terminal N), and one neutral (terminal B). The position feedback potentiometer connections are available at terminals CC (Reverse), DD (Wiper), and EE (Forward).

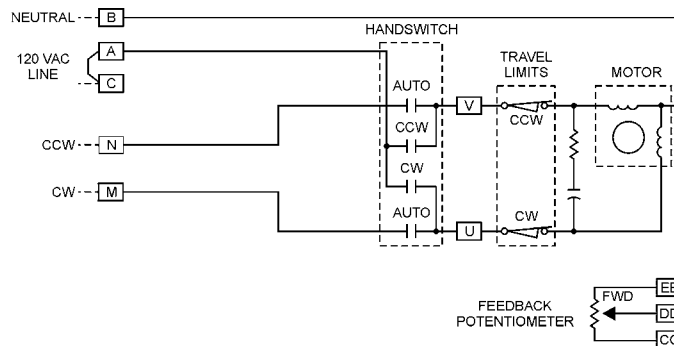

Option 4, Multi-Position

Direct AC Control with Cam-Operated Switches to Stop Actuator Travel

Customer must supply three wires to directly control the actuator motor direction: One 120 V ac line to run CW (terminal M), one 120 V ac line to run CCW (terminal N), and one neutral (terminal B). Up to six intermediate stop positions may be specified, each requiring an additional 120 V ac line.

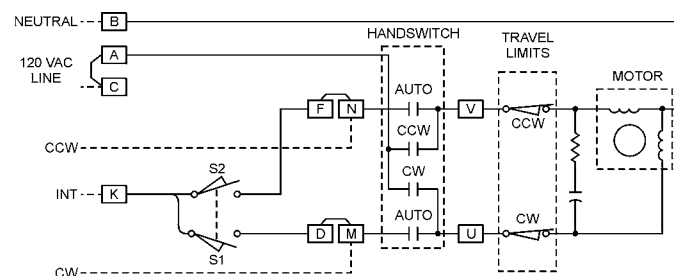

Option 3, Open / Close

Direct AC Control

Customer must supply three wires to directly control the actuator motor direction: One 120 V ac line to run CW (terminal M), one 120 V ac line to run CCW (terminal N), and one neutral (terminal B).

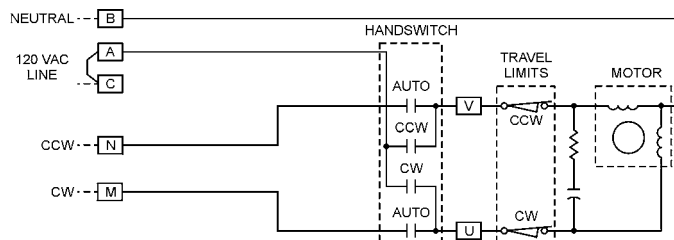

240 V ac Operation

All of the options described above are available for 240 V ac operation instead of 120 V ac operation. In all cases, the power neutral is replaced with Line 2 of the 240 V ac, and the 120 V ac line is replaced with Line 1 of the 240 V ac.

INSTALLATION Feedback Signal Wiring

CPS-5 SIGNAL CONNECTIONS

Beck 11-430 actuators equipped with the Contactless Position Sensor (CPS-5) are shipped ready for installation.

Customer connections for feedback signal wiring are described below. Refer to Table 11, page 39 for additional information.

The value of the R8 Feedback Gain Resistor affects output shaft rotation range; where: R8 = 100 K ohms produces a shaft output range of 80–100°; R8 = 249 K ohms produces a shaft output range of 70–80°; and R8 removed produces a shaft output range of 60–70° (see Figure 5, page 27 for location of R8).

CPS-5 Model 20-4400-02 Terminal Connections

1. A single 4–20 mA current output is available between terminals EE (+) and CC (-) when driving into an external load between 250 and 800 ohms. No ranging resistor is required.
2. 4–20 mA output is also available across EE (+) and DD (-); 500 ohms is the maximum external load (for larger loads see Item 1 above).

4-20 mA Signal Output

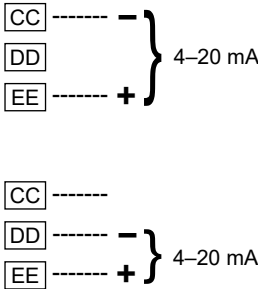

INSTALLATION Start-Up

START-UP INSTRUCTIONS

After the actuator is mounted and its wiring connections are made, it is ready to be tested for proper operation.

NOTE: All Beck actuators are shipped from the factory ready for installation; no electrical adjustments are required before placing them in operation. Each actuator is set up and calibrated to the customer's specifications that were written into the equipment order.

Turn on the power supply. Operate the actuator with the Handswitch and run it through its full stroke in both directions. Observe that the driven device travels through its desired stroke. If satisfactory, set Handswitch to the AUTO position.

If the actuator is to be operated with automatic control, turn on the controller and operate the actuator by varying the control signal. Check that the driven shaft strokes in the proper direction for a change in control signal. If it does not, first check for proper wiring connections and verify control signal at the actuator. If the wiring is correct, then reverse the direction of travel (see page 23).

If the actuator is to be push-button actuated, (options 3, 4, 5, or 6) operate the actuator using the Handswitch and observe that direction of travel is correct. When travel of the driven device is satisfactory with reference to the control signal or the push-buttons, the unit is ready for operation.

LINKAGE REQUIREMENTS

In most applications, the best control will result when the linkage is adjusted so that the full 100° angular travel of the Beck actuator shaft is used, even though the driven shaft may travel less than 100°.

The general requirements for a good linkage are:

1. It must be rigid enough to carry the link thrust without bending or deforming.
2. It must have a built-in means of adjustment so that the length of the connecting link can be changed a small amount.
3. Rod end bearings, similar to those furnished on the Beck crank arm, should be used at both ends of the connecting link. This type of device permits small angular misalignments and helps prevent binding of the linkage.
4. The radius of the Beck crank arm must be calculated so that it will move the damper lever through the correct arc as it travels from 0° to 100°.

5. The actuator and driven shafts must be parallel and the linkage should be in a plane perpendicular to the shafts.

The following procedure is recommended to couple the linkage between the Beck actuator and the driven shaft:

1. Position the driven shaft to its fully closed position.
2. Set the driven shaft lever to its predetermined starting angle in relation to the driven shaft and actuator shaft centerline.
3. Remove the rod end from the Beck crank arm. Thread the rod end fully onto the connecting link.
4. Adjust the connecting link to the predetermined length.
5. Connect the connecting link to the driven lever at the predetermined radius.
6. Set the crank pin (see illustration on page 9) on the Beck crank arm to the predetermined radius (9–15 inches (228–381 mm) or 6.5–10.5 inches (165–266 mm), depending on the crank arm); this is done by loosening the crank pin screws and sliding the crank pin to the predetermined position. Tighten the crank pin screws to the torque recommended on page 8.
7. Loosen the crank arm screws.



CAUTION

The crank arm will pop free (approx. 125 lbs (57 kgs)) allowing adjustment for 360° around the shaft.

8. Position the actuator's output shaft to correspond with the driven shaft's fully closed position.
9. Swing the crank arm into position and assemble the rod end to the crank arm crank pin. Tighten the rod end nut to the torque recommended on page 8.
10. Tighten the crank arm screws evenly, in a cross-pattern, to the torque recommended on page 8.
11. Lubricate the rod end bearings with LGI #1 EP grease, Mobil grease #28 or equivalent.
12. Carefully move the actuator's output shaft to correspond with the driven shaft's fully open position. Check that no binding occurs between the linkage, crank arm, driven shaft lever, and surrounding obstructions. Also, observe that the driven shaft rotates the proper amount. Ensure that the actuator reaches the proper limit and shuts off. If binding in the linkage occurs due to too much travel of the driven lever, reduce the crank arm radius on the Beck actuator rather than adjusting the connecting link length. Return to step 5 and repeat adjustments.

If necessary, the linkage length may be adjusted by altering the thread engagement in the couplings. The couplings have right- and left-hand threads, so it is not necessary to disconnect the ends to make a length adjustment. The stud threads must be engaged 1.2 diameters deep into the rod ends. Make adjustments by altering thread engagement in couplings only. Be careful not to expose more than 7" (178 mm) of stud between rod end and coupling.

Once again, check operation to determine that no binding occurs between the linkage and crank arm or driven shaft lever. Surrounding objects must not interfere.

Do not change limit switch settings to obtain desired driven shaft lever travel. This shortens the travel of the feedback device and reduces the control resolution, repeatability, accuracy of the actuator, and available torque.

Link-Assist™

The Beck Link-Assist™ computer program optimizes the linkage configuration for your load's torque characteristics to help you select the minimum actuator size for your application. Contact your Beck Sales Engineer to take advantage of Beck's Link-Assist™ program.

Linkage Kits Available

Standard Beck linkage kits are made to accommodate a wide variation in linkage lengths without requiring modification of end fittings. This adaptability makes it possible to order the essential linkage end connections even though the exact linkage length may not be known until the actuator is mounted in place.

Each linkage kit includes the essential pipe linkage end connections and all necessary hardware except for pipe and crank arm rod end. To simplify installation of the pipe link, the

kit accepts N.P.T. right-hand threads on both ends of the pipe. Left-hand threads are internal to the linkage kit assembly, making final length adjustments quick and easy.

To order Pipe Linkage Kits, first obtain the approximate overall linkage length "A". Select the kit part number from Table 3, below. For lengths beyond those listed in the table, contact your Beck Sales Engineer. Additional Linkage information can be found in the Beck Actuator Catalog (DSG).

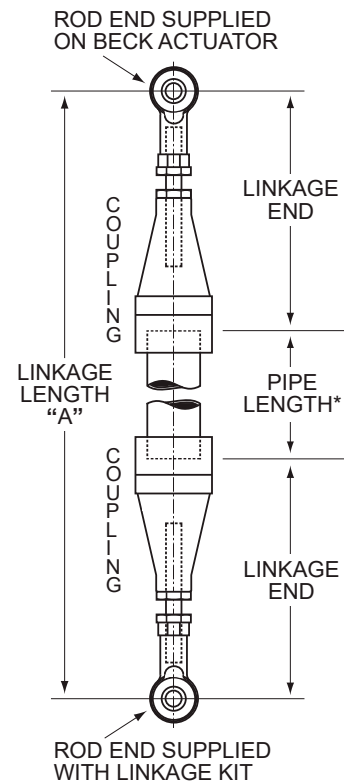

*NOTE: To calculate length of pipe required, subtract "Length of 2 Linkage Ends" (shown in Table 3 below) from Linkage Length "A" (shown in diagram above).

**TABLE 3:
11-430 PIPE LINKAGE KITS**

Linkage Length Range "A"	Pipe Size	Min. Pipe Nipple Length	Rod End Thread (UNF)	Beck Pipe Linkage Kit Part No.	Length of 2 Linkage Ends (Total Adj. $\pm 1 \frac{1}{2}$ " (38 mm))	Approx. Weight ¹
23 1/2–40" (597–1016 mm)	2" (51 mm)	2" (51 mm)	1 1/2-12	20-1760-13	21 1/2" (546 mm)	28 lbs (13 kg)
37 3/4–144" (959–3658 mm)	3" (76 mm)	2 5/8" (67 mm)	1 1/2-12	20-1760-10	35 1/8" (892 mm)	32 lbs (15 kg)
59 3/4–144" (1518–3658 mm)	3" (76 mm)	2 5/8" (67 mm)	1 1/2-12	20-1760-09 ²	57 1/8" (1451 mm)	41 lbs (19 kg)

¹Does not include customer supplied pipe.

²Use when the angle between the linkage and crank arm is less than 25°.

OPERATION

HOUSING

The 11-430 consists of a Beck 11-400 actuator assembled to a 3:1 gear reduction unit. The 11-400 has cast aluminum compartments for each of the five main components: The control motor, wiring terminal board, drive train, electronic signal receiver, and control end. Gasketed covers and sealed shafts make this product ideally suited to outdoor and high-humidity environments.

The gear reduction unit is cast aluminum and provides a rugged, dust-tight, weatherproof enclosure.

CONTROL MOTOR

The Beck control motor is a synchronous inductor motor that operates at a constant speed of 72 or 120 RPM in synchronism with the line frequency.

Motors are able to reach full speed within 25 milliseconds and stop within 20 milliseconds; actual starting and stopping times will vary with load.

Beck motors have double grease-sealed bearings and require no maintenance for the life of the motor.

GEAR TRAIN

The 11-400 gear train is a four-stage reduction, spur gear drive constructed with only heat-treated alloy steel and ductile iron gears for durability and long life.

The drive train consists of the control motor and Handwheel, reduction gears, main gears, and splined output shaft. The main gear / output shaft and third stage gears are built into the actuator housing. The second and first stage gears are part of the field-interchangeable gear module. Different combinations of gear modules and actuator motors determine the actuator's output torque and timing.

The drive train in the gear reduction unit is a single-stage reduction, spur gear drive consisting of a ductile iron gear and a heat-treated alloy steel pinion. An internal spline in the pinion engages with the external spline on the output shaft of the 11-400. In this way, the output torque of the 11-400 is increased by a factor of 3.

The output shaft is limited by mechanical stops to 108° of rotation. Mechanical transmission of the output shaft position to the control end is provided by a right angle gear set driven directly by the 11-400 output shaft.

SELF-LOCKING MECHANISM (SLM)

An integral part of the 11-430 control motor is the self-locking mechanism. This mechanical device couples the motor to the gear train and transmits full motor torque when rotated in either direction. When the motor is de-energized, it instantaneously locks and holds the output shaft in position, up to two times the rated torque of the actuator.

HANDWHEEL

The 11-430 actuator is furnished with a Handwheel for movement of the driven shaft without electrical power. Its solid construction design includes no spokes or projections, and turns at a safe, slow speed. The Handwheel is located at the rear of the control motor housing. The Handwheel is coupled directly to the motor shaft and rotates when the motor runs. Manual operation of the Handwheel (with electric Handswitch in STOP position) turns the motor and the rest of the drive train without incorporating a clutch.

HANDSWITCH

A local electric Handswitch is provided on Beck actuators to permit operation at the valve or damper, independent of the controller. As a safety feature, the Handswitch is designed so that the controller can operate the actuator only when it is in the AUTO position. The sequence of the Handswitch is: AUTO, STOP, CW, STOP, CCW.

In the "AUTO" position, two contacts are closed and the external controller contact completes the control circuit.

In the CW or CCW positions, contacts are closed to operate the actuator independently of the controller.

In the STOP position, all contacts remain open.

SWITCHES

Two over-travel limit switches (control options 5 and 6) or two end-of-travel limit switches (control options 3 and 4) and up to four optional auxiliary switches are provided on the 11-430 actuator. Switch cams are clamped onto the control shaft, which rotates in relation to the output shaft. Cam position is field-adjustable. Switches are rated 6A, 120 V ac; .5A, 125 V dc; .25A, 250 V dc. All auxiliary switch connections are made on the terminal block.

CONTROL OPTIONS

120 V ac control options are described below.

Open / close option 3: For simple 2-position control using manual push-buttons or an automatic controller. Preset travel limit switches provide open / close operation upon closure of an automatic controller or manually operated switch. Travel limits are adjustable over the full range of travel and provide precise positioning repeatability.

Multi-position option 4: Adjustable cam operated switches provide up to six discrete stop positions upon closure of an automatic controller or manually operated switch. Three, four, five, and six predetermined position settings are possible, with precise positioning repeatability.

Direct ac control option 5: Provides continuous positioning capability over the full range of actuator travel by direct ac control from either an automatic controller or manually operated switches. Includes a 1,000 ohm film potentiometer for remote feedback.

Direct ac control option 6: Provides continuous positioning capability over the full range of actuator travel by direct ac from either an automatic controller or manually operated switches. Includes Contactless Position Sensor (CPS-5) for feedback and position indication.

With control options 5 & 6, an optional Relay Board is available to permit operation on low-power DC voltage input signals (5–24 V dc) or, with an external diode / resistor module, on low-power 120 V ac. This topic is covered beginning on page 28.

POSITION FEEDBACK: CONTACTLESS POSITION SENSOR (CPS-5)

The CPS-5 provides a continuous feedback signal proportional to the position of the actuator's output shaft. The position sensing function of the CPS-5 is provided by a ferrite magnetic sensing element. An electronic circuit translates the signal from the ferrite magnetic sensor into an analog position feedback signal designed to interface with electronic control systems and indicating instruments.

OPERATION

POSITION FEEDBACK: FILM POTENTIOMETER

The film potentiometer produces a voltage that is some fraction of the voltage applied across its resistive element. That voltage fraction is determined by the position of the wiper on the resistive element. The potentiometer assembly also includes two fixed resistors, one on each end of the resistive element. These resistors permit suppressed ranges as well as zero-based position feedback voltages.

STALL PROTECTION

The Beck Stall Protection Module is an optional feature of the 11-430 Actuator (240 V ac actuators cannot utilize the SPM). The SPM monitors the motor current at terminals N and M. The SPM will be activated when the actuator cannot reach a desired position within approximately 300 seconds. When a stall is sensed, the SPM shuts off power to the motor and a solid state relay in the SPM changes state. The relay is rated for 120 V ac or dc, 10 VA. Two terminals connected to the solid state

relay are located on the SPM. Use of the relay for annunciation of a stall is optional and will not affect the other functions of the SPM. A sensed stall condition is cleared by either reversing the motor direction command in the controller, or by turning the actuator power off and on. An LED is included on the SPM to show the operating status of the module.

NOTE: Your Beck actuator was shipped from the factory ready for installation; no electrical adjustments are required before placing it in operation. Each actuator is set up and calibrated to the specifications written into the equipment order.

Under normal operating conditions there is no need to recalibrate the actuator. However, if requirements change or differ from the equipment order, the actuator should be recalibrated according to the "Calibration" section beginning on page 21.

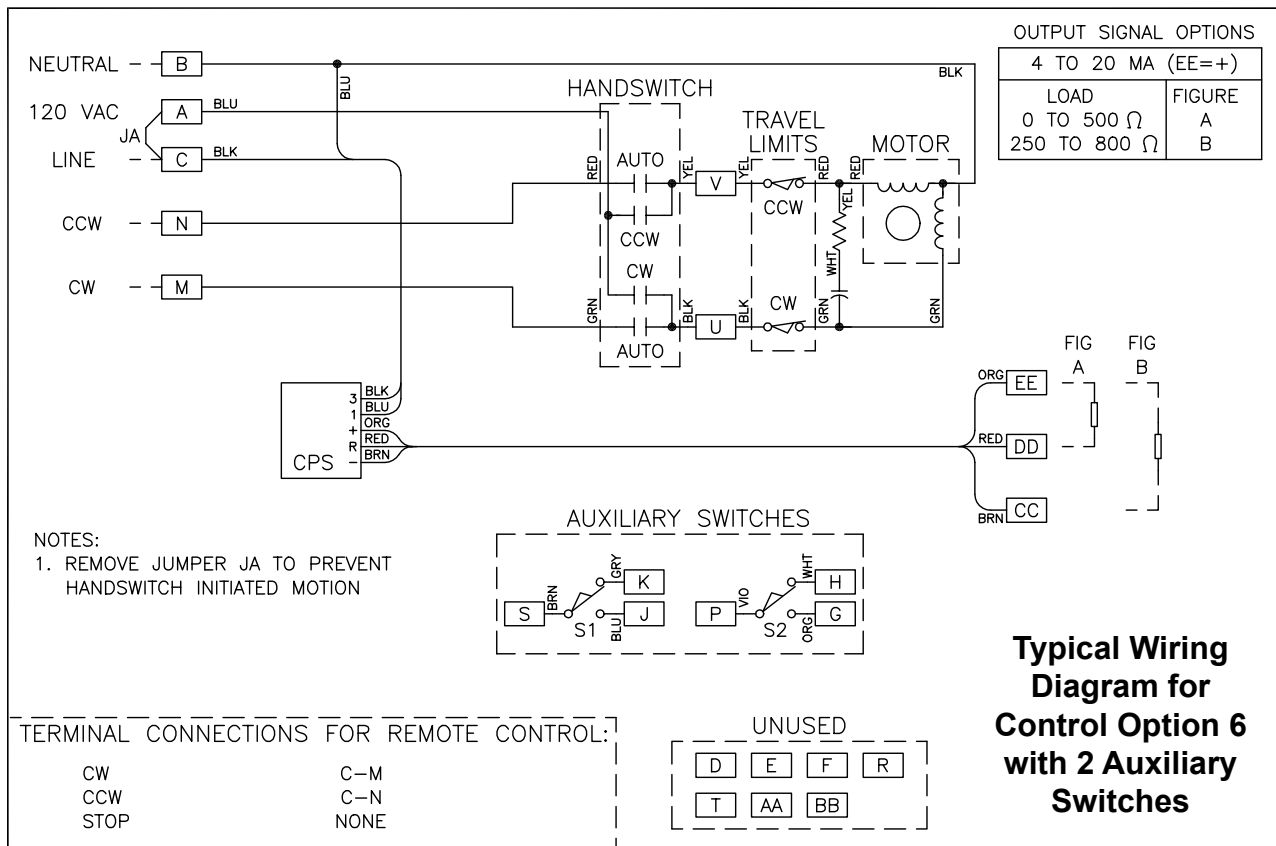

CALIBRATION Switches

SWITCH ADJUSTMENTS

Over-travel limit switches (options 5 and 6) are factory set $1/2^\circ$ outside each end of travel unless otherwise specified at time of order. End-of-travel limit switches (options 3 & 4) are factory set at each end of travel unless otherwise specified at time of order. Limit switches must be set inside the range of the built-in mechanical stops to prevent stalling of the motor. Limit switches can be reset to limit travel of the output shaft to any angle down to a minimum of approximately 60° . Auxiliary switches are set as shown in the illustration at left unless otherwise specified at time of order.

NOTE: On Beck 11-430 actuators, the control end cover may consist of two or three parts (cover plus cover extensions). The travel limit switches are located next to the actuator body. To adjust the travel limit switches, it is necessary to remove the control end cover and all cover extensions.

Switches are operated by cams which are clamped on to the control shaft. Setting a switch involves loosening the cam, moving the output shaft to the desired position, and positioning the cam so that it just operates the switch at that point. In the following procedure, the use of a continuity meter is recommended to determine when the switch opens or closes. If such a meter is not available, it is possible to hear the switch click as the contacts open and close.

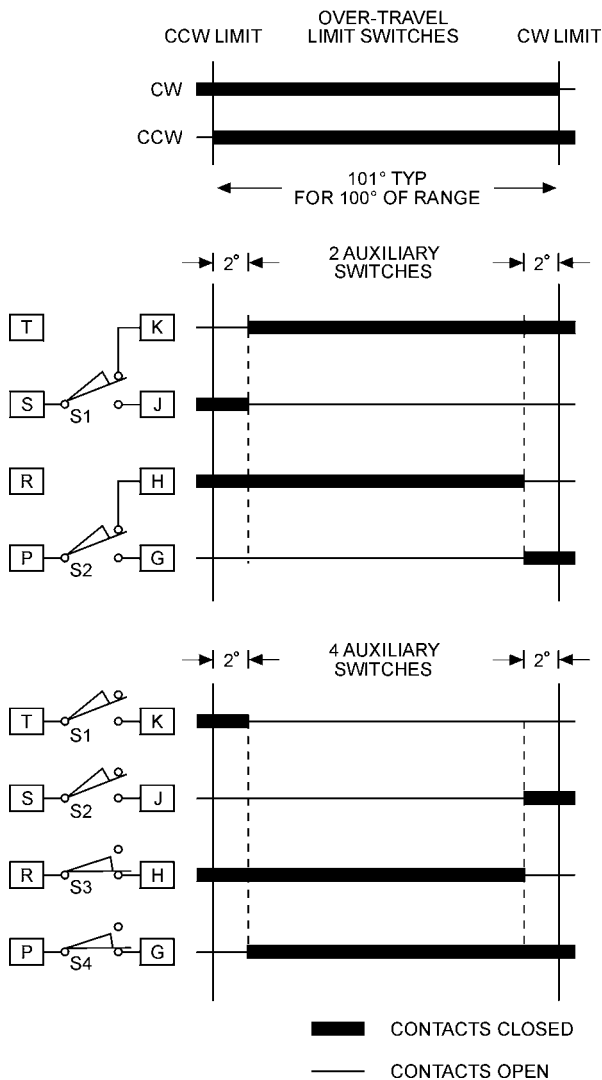

**STANDARD LIMIT
AND AUXILIARY SWITCH SETTINGS**



CAUTION

Do not attach the meter or attempt to move the switch cams until the actuator is disconnected from the line voltage and auxiliary switches are disconnected from external power sources.

CALIBRATION Switches

Setting Limit Switches CW and CCW

Use this procedure to change the factory limit switch settings in the field. Operate the actuator fully in each direction using the electric Handswitch to check switch settings before attempting to change them.

1. Remove the control end cover and cover extensions, if applicable, and terminal block cover (5/16" bolt heads).
2. Use the electric Handswitch to drive the control shaft so that the CW switch cam screw is accessible. Using a 7/64" hex wrench, loosen the screw so that the cam is just snug on the shaft. See Figure 2, below.



Figure 2

3. Move the output shaft clockwise to the desired maximum CW limit switch position (for options 5 and 6, this position should be just outside the desired CW electronic travel position).
4. Turn the Handswitch to the "STOP" position.
5. **Disconnect power from the actuator.**
6. Turn the Handswitch to the "AUTO" position.
7. Connect the continuity meter across terminals B and M. Rotate the cam until the meter shows no continuity (switch contacts open, switch clicks).
8. Tighten the cam locking screw to 5 lb-in (0.56 N•m) torque.
9. Disconnect the meter and turn the Handswitch to the "STOP" position.
10. Reconnect actuator power.
11. Rotate the actuator's output shaft in the CCW direction away from the CW limit switch position. Note the direction of rotation of the lobe of the cam. The correct cam lobe motion is away from the switch lever with the switch lever on the lower part of the cam. If not

correct, return to step 2 and reset the cam to the proper orientation.

12. Rotate the output shaft again to the desired CW travel limit. If the desired stopping point is reached, the switch is properly set.
13. Repeat instructions for setting CCW limit switch position (noting that referenced directions of rotation should be opposite of those used for CW switch setting). Connect continuity meter across terminals B and N.
14. Replace covers and tighten cover bolts to 10 lb-ft (14 N•m) torque.
15. Adjust the index to correspond with the output shaft rotation.

Setting Auxiliary Switches

Standard switch settings for actuators with 2 or 4 auxiliary switches are shown on the diagram on page 21. The heavy line indicates a closed circuit. Follow these instructions to change the operating point of auxiliary switches:

NOTE: In the following procedure, it is assumed that switch settings are set so that contacts are open when the desired position is achieved. If set to close, it may be necessary to reverse the operating mode of the switch by reversing the leads on the switch itself. Disconnect power from the switch terminals first.

1. Remove the control end cover and cover extensions, if applicable, and the terminal block cover (5/16" bolt heads).
2. Use the electric Handswitch to drive the shaft so that the switch cam is accessible. Using a 7/64" hex wrench, loosen the screw so that the cam is just snug on the shaft.
3. Move the output shaft to the desired position.
4. Turn the Handswitch to the STOP position.
5. Disconnect power from the actuator and switch terminals.
6. Connect the continuity meter across the appropriate terminals. See the diagram on page 20 or the actuator wiring diagram. Rotate the cam to operate the switch.
7. Tighten the cam locking screw to 5 lb-in (0.56 N•m) torque.
8. Disconnect the meter and reconnect power.
9. Rotate the actuator's output shaft in the desired direction so that the cam lobe moves away from the switch lever. If not correct, return to step 2 and reset the cam to the proper orientation.
10. Replace covers and tighten bolts to 10 lb-ft (14 N•m) torque.

CALIBRATION *Direction Change*

CHANGING DIRECTION OF OUTPUT SHAFT ROTATION

The direction of output shaft rotation is determined by observing the end of the actuator output shaft. The rotation direction desired from an increasing signal—clockwise or counterclockwise—should be specified at the time of order. If not specified, the output shaft is factory-set to rotate clockwise in response to an increasing signal.

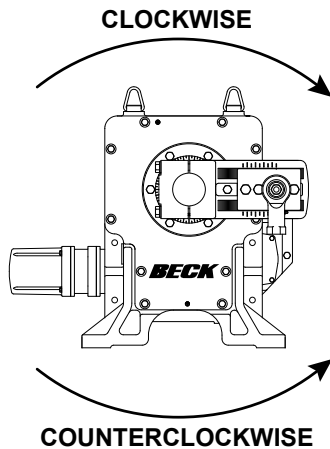

Figure 3

The procedure to change the direction of travel of the output shaft varies by model number. The model number is listed on the actuator nameplate. Determine the model number and refer to one of the following procedures:



CAUTION

Be sure the actuator is disconnected from the line voltage and that all auxiliary switches are disconnected from the external power sources before beginning the direction change procedure.

Models 11-433 and 11-434

No changes are necessary for these models.

Models 11-435

1. Remove the control end cover and extensions if applicable (5/16" bolt heads).
2. Interchange the yellow and black wires on the common terminals of the CW and CCW travel limit switches.
3. Interchange the wires connected to the ends of the potentiometer. The wire on terminal 1 or 5 should be moved to the opposite terminal. Also move the wire on terminal 2 or 4 to the opposite terminal. The wire to terminal 3 remains unchanged. See Table 4, below.
4. Reset the potentiometer wiper according to the instructions on page 25.

Auxiliary Potentiometer Only

4. Reverse the wires connected to the ends of the potentiometer. The wire on terminal 1 or 5 or on terminal 2 or 4 should be moved to the opposite terminal (See Table 4).
5. Replace the control end covers. Torque the cover bolts to 10 lb-ft (14 N•m).

TABLE 4:
SHAFT ROTATION, FEEDBACK, AND METER CONNECTIONS

Model	Output Shaft Rotation Increasing Signal	Control Shaft Rotation	Remote Feedback Terminal Connections			Wiring Connections to Potentiometer Terminals				
			(+)	Supply Voltage	(-)	Meter Connections				
						(+) Fdbk	(-)	1	(-) 2	(+) 3
435	CW	CW	EE	DD	CC		GRN	YEL		ORG
	CCW	CCW	EE	DD	CC	ORG		YEL	GRN	

CALIBRATION *Direction Change*

Model 11-436

1. Open the terminal compartment (5/16" bolt heads) and remove the control end cover (5/16" bolt heads) and extensions, if applicable.
2. Interchange the yellow and black wires on the common terminals of the CW and CCW travel limit switches.
3. Determine the correct feedback signals from the wiring diagram supplied with your actuator (CC, DD, EE).
4. Record the color and location of the feedback signal wires for reconnection later. Remove the two feedback wires. Connect the mA meter in series with a 200 ohm load resistor.
5. Reconnect actuator power.
6. Drive the output shaft until the CPS-5 output is 50% of the range (e.g., for 4–20 mA signal range, set output to 12 mA).
7. Set Handswitch to STOP position.
8. Using a 7/64" hex wrench, loosen the CPS-5 rotor clamp.
9. Rotate the CPS-5 rotor 180° and set the output back to the mid-range (e.g. 12 mA).
10. Tighten the rotor clamp. See Figure 4, below.
11. Run the actuator to the 0% and 100% limits using the Handswitch. Record CPS-5 output at these limits.
12. Subtract the outputs recorded at the two limits and compare with the desired output signal span (e.g., 16 mA for a 4–20 mA signal range). The difference between the measured span and the desired span is the error.
13. With the actuator at the 100% limit, turn the span potentiometer to adjust the CPS-5 output signal by 1/2 of the span error calculated in step 12. Turning the span potentiometer CW increases the span equally at both ends. See Figure 5, page 27, for the location of the span potentiometer.
14. Loosen the CPS-5 rotor clamp and rotate to achieve the desired value of maximum output signal (e.g., 20 mA for a 4–20 mA signal range). Rotation of the CPS-5 rotor moves the entire signal span up or down.
15. Tighten the CPS-5 rotor clamp to 5 lb-in (0.56 N•m) torque. Maintain a 0.031" (.8 mm) clearance between the rotor clamp and stator.
16. Run the actuator to 0% and 100% limits and check the output signal for desired span. If not correct, repeat the procedure from step 11.
17. Remove the meter and resistor and reconnect the feedback wiring.
18. Replace covers and tighten cover bolts to 10 lb-ft (14 N•m) torque.

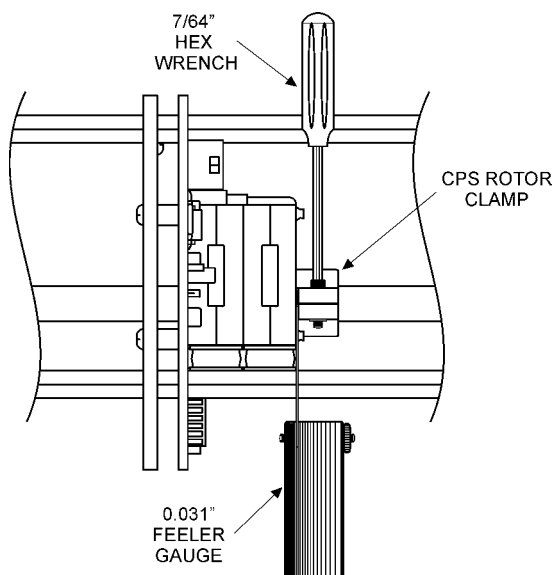

Figure 4

CALIBRATION Feedback Signal

FEEDBACK SIGNAL CALIBRATION

Feedback signal calibration is necessary to ensure that signal current or voltage correctly corresponds to the actuator's output shaft position. The 11-430 actuator is shipped with the feedback calibrated for full 100° travel of the output shaft unless otherwise specified at the time of order. Minimum shaft travel available is 60°.

The procedure to check and set feedback calibration varies by model number. The model number is listed on the actuator nameplate. Refer to the proper procedure below.

NOTE: The limit switches must be properly adjusted before the feedback signal is calibrated. The feedback signal must be calibrated before the input signal is calibrated.

Film Potentiometer Calibration Models 11-435

Properly adjusted, the auxiliary potentiometer feedback signal should be maximum with the actuator shaft at the 100% (maximum input signal) position. At 50% of travel, the signal should be mid-span. At 0%, the signal should be minimum.

If the feedback potentiometer on 11-435 units is out of calibration, the procedure to recalibrate is as follows:

1. Remove the Electronics compartment cover and the control end cover (5/16" bolt heads).
2. Loosen the clamping screw (use 9/64" hex wrench) on the potentiometer wiper so that it is just snug on the shaft.
3. Move the actuator to the 0% position.
4. Set the wiper about 5 degrees above the position where the minimum output is reached, or as required by the control system. See Table 4, page 23.

NOTE: Be sure that the wiper spans the resistor and collector elements equally, and does not touch the areas of low resistance at either end of the film element.

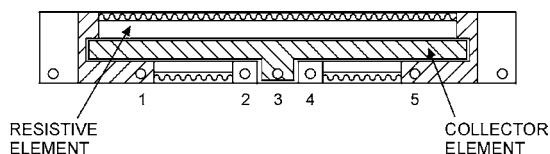

5. Tighten the clamping screw to 5 lb-in (0.56 N•m) torque.
6. Operate the actuator between the electrical limits. Verify that the feedback signal is properly adjusted.

7. Use the manual Handwheel to move the actuator to the mechanical limit; do not over-torque, as damage may result.
8. Check that the wiper does not come off the resistive element. This may be verified by monitoring the output voltage and ensuring it does not fall from maximum value. If not correct, return to step 2.
9. Replace the covers and tighten the cover bolts to 10 lb-ft (14 N•m).

CPS-5 Calibration Model 11-436

These models are equipped with a Contactless Position Sensor (CPS-5) for position sensing and feedback. CPS-5 units provide position feedback without contacting or wiping surfaces.

The CPS-5 provides infinite resolution by incorporating a ferrite rotor on the control shaft and a ferrite stator mounted on the position sensing circuit board. To make feedback signal adjustments, adjust the span, then change the position of the rotor on the control shaft to adjust the zero.

Checking Feedback Signal Calibration

The following procedure should be followed to check CPS-5 calibration:

Tools required:

- mA / V dc Multimeter
- 1/2" Combination Wrench
- 200 ohm Resistor

1. Put electric Handswitch in STOP position.
2. Remove the terminal block cover and the control end cover (5/16" bolt heads).
3. Determine the correct feedback terminals from the wiring diagram supplied with your actuator (CC, DD, EE).
4. Record the color and location of the feedback signal wires for reconnection later. Remove the two feedback wires. Connect a mA meter in series with a 200 ohm load resistor.
5. Drive the output shaft through its full range and check the feedback signal.

When properly adjusted, the feedback signal should be maximum with the actuator's output shaft at the 100% (maximum input signal) position. At 50% travel, the signal should be mid-span. At the 0% position, the signal should be minimum. If not correct, proceed with the calibration procedure.

CALIBRATION Feedback Signal

Note: Tolerance on factory calibration is $\pm 0.5\%$ of span.

Calibration Procedure

Adjustment of the CPS-5 is necessary if the signal range requires an increase or decrease in value relative to the actuator's output shaft rotation. Calibrate by turning the Span Potentiometer CW to increase the gain of the CPS-5. This has the effect of increasing the output at the high end and lowering the output at the low end equally.

To adjust the span, turn the Span Potentiometer on the CPS-5 circuit board. The Span Potentiometer adjusts the CPS-5 so that the actuator output shaft rotation from 80° to 100° produces the specified output signal range.

For output shaft rotation of between 60° and 79°, it may be necessary to remove resistor R8 (100 K ohm), which is on raised turrets, to change the range of the span adjustment. An R8 value of 100 K ohms produces a shaft output range of 80° to 100°; an R8 value of 249 K ohms produces a shaft output range of 70° to 79°; and removing R8 produces a shaft output range of 60° to 69°. See Figure 5, page 27, for location of R8.

Tools required for calibration:

- mA / V dc Multimeter
- 3/32" Screwdriver
- 7/64" Hex Wrench
- 1/4" Screwdriver
- 1/2" Combination Wrench
- 1/32" Thickness Feeler Gauge
- 200 ohm Resistor

1. Put electric Handswitch in STOP position.
2. Remove the terminal block cover and the control end cover (5/16" bolt heads).
3. Determine the correct feedback terminals from the wiring diagram supplied with your actuator (CC, DD, EE).
4. Record the color and location of the feedback signal wires for reconnection later. Remove the two feedback wires. Connect a mA meter in series with a 200 ohm load resistor.
5. Run the actuator to the 0% and 100% limits using the Handswitch. Record the CPS-5 output at these limits.
6. Subtract the outputs recorded at the two limits and compare with the desired output signal span (e.g., 16 mA for a 4–20 mA signal range). The difference between the measured span and the desired span is the span error.
7. With the actuator at the 100% limit, turn the span potentiometer to adjust the CPS-5 output signal by 1/2 of the span error calculated in step 6. Turning the span potentiometer CW increases the span equally at both ends. Turning the span potentiometer CCW decreases the span equally at both ends. See Figure 5, page 27, for the location of the span potentiometer.
8. Loosen the CPS-5 rotor clamp and rotate to achieve the desired value of maximum output signal (e.g., 20 mA for a 4–20 mA signal range). Rotation of the CPS-5 rotor moves the entire signal range up or down.
9. Tighten the CPS-5 rotor clamp to 5 lb-in (0.56 N•m) torque. Maintain a 0.031" (.8 mm) clearance between the rotor clamp and stator.
10. Run the actuator to the 0% and 100% limits and check the output signal for desired span. If not correct, repeat the procedure from step 5.
11. Remove the meter and resistor and reconnect the feedback wiring.
12. Replace covers and tighten the cover bolts to 10 lb-ft (14 N•m) torque.

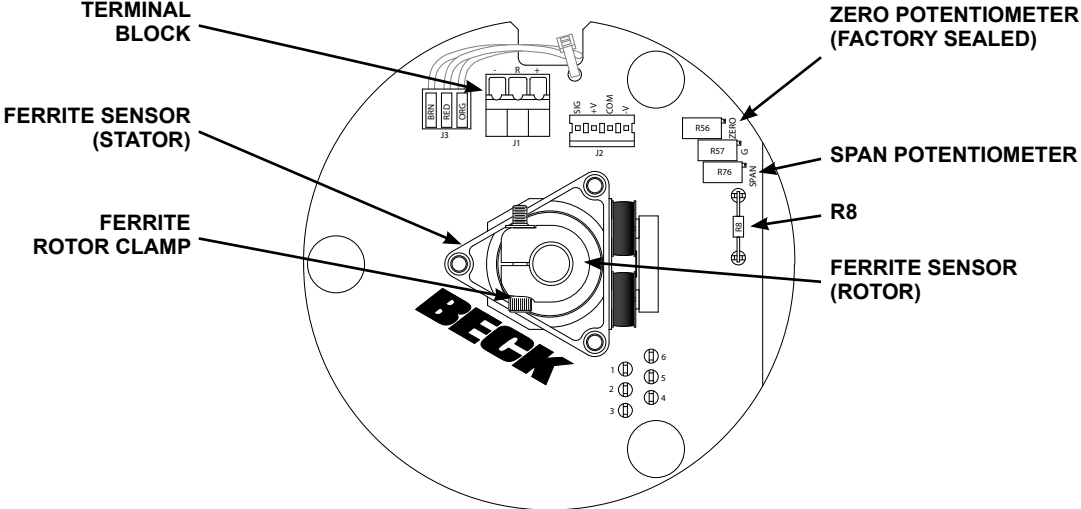

CPS-5 POSITION SENSOR
Figure 5

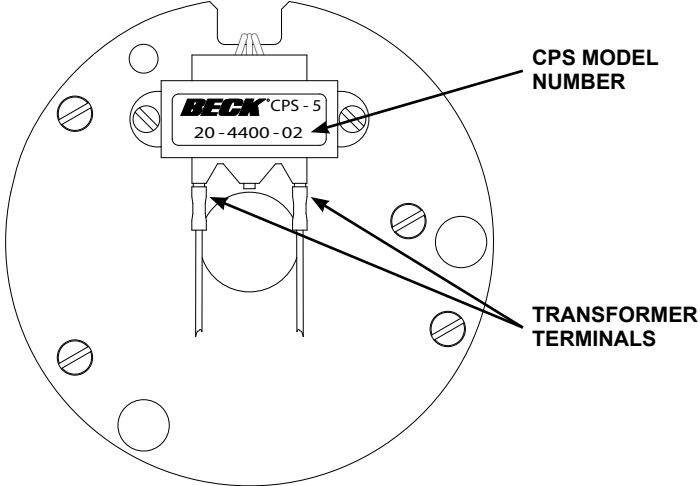

CPS-5 (TRANSFORMER SIDE)
Figure 6

CALIBRATION Demand Signal

RELAY BOARD OPERATION AND CALIBRATION

The Relay board is a solid-state interface to permit switching large control motor currents with low-current ac or low-voltage dc inputs.

The purpose of calibrating the Relay Board is to ensure that clockwise and counterclockwise input signals are balanced (e.g., if a 24 V dc signal runs the actuator in the clockwise direction, a -24 V dc signal should run the actuator in the counterclockwise direction, and the actuator should not run when the signal is zero).

Two calibration procedures follow. The first applies to low current 120 V ac input signals. The second applies to low voltage 24 V dc input signals.

Low current 120 V ac Relay Board Calibration Procedure (Relay Board 13-2246-50):

1. Disconnect actuator from line voltage and remove terminal cover and ESR cover (5/16" bolt heads).
2. Remove input signal wires from terminals AA and BB.
3. Attach voltmeter to test points TP1 (+) and TP2 (-). See Figure 8, below, for location of test points on the Relay Board.
4. Turn on line voltage.
5. Adjust potentiometer R3 to bring meter reading to $+0.17 \text{ volts} \pm 0.01 \text{ V dc}$. See Figure 8 for location of potentiometer R3.
6. Disconnect actuator from line voltage and reconnect input signal wires to terminals AA and BB.
7. Check operation of actuator with system signals.
8. Replace covers and tighten cover bolts to 10 lb-ft (14 N•m) torque.

NOTE: When used in low-current AC applications, the Relay Board provides a 10 mA load to the controller outputs. If the controller outputs require greater than a 10 mA holding current, the user must provide additional load external to the actuator using resistors from each input to neutral (actuator terminals F to E and D to E). Since these resistors generate heat, sufficient means for cooling must be provided.

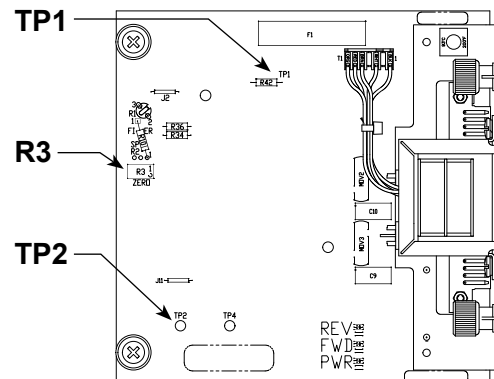

**Low Current 120 V ac
Relay Board Components**

Figure 8

Low voltage 24 V dc Relay Board Calibration Procedure (Relay Board 13-2246-51):

1. Disconnect actuator from line voltage and remove terminal cover and ESR cover (5/16" bolt heads).
2. Remove input signal wires from terminals AA and BB.
3. Attach voltmeter to test points TP1 (+) and TP2 (-). See Figure 9, this page, for location of test points on the Relay Board.
4. Turn on line voltage.
5. Adjust Zero Potentiometer R3 for -0.2 V at TP1 with neither input signal applied. See Figure 9 for location of Zero Potentiometer R3.
6. Adjust Span Potentiometer R2 for -0.2 V at TP1 with both input signals applied simultaneously. See Figure 9 for location of Span Potentiometer R2.
7. Disconnect actuator from line voltage and reconnect input signal wires to terminals AA and BB.
8. Check operation of actuator with system signals.
9. Replace covers and tighten cover bolts to 10 lb-ft (14 N•m) torque.

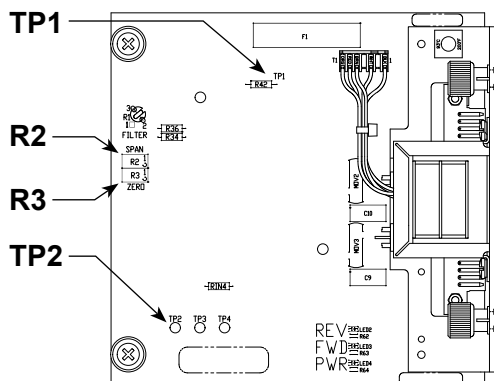
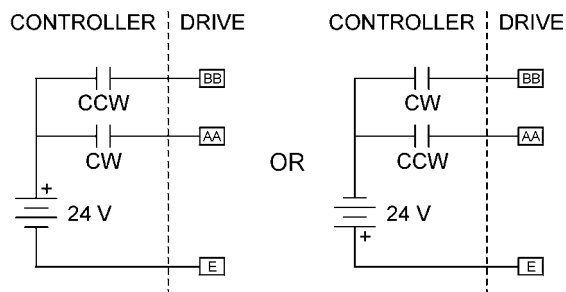

**Low Voltage 24 V dc
Relay Board Components**

Figure 9

MAINTENANCE Routine

The Beck 11-430 actuator requires only minimal routine maintenance. Periodic lubrication of the gearing is recommended to extend gear life. Periodic visual inspections are recommended to verify that the connection to the final control element is intact and operating normally. If vibration is present, check the electrical terminal connections and other hardware for tightness. Inspections of body mounting bolts and crank arm linkages are also recommended to ensure the actuator elements are secure and operating normally.

To inspect the gears on the gear reduction unit, remove the gear inspection plug (see photo below for location). If possible, move the output shaft to the full CW or CCW limit of travel. This will expose the gear teeth in use on the output gear. Turn the Handswitch to the STOP position. Recoat the gear teeth with a heavy layer of Fiske Lubriplate GR-132 or equivalent. Replace the gear inspection plug.

LUBRICATION

It is recommended that during major outages, actuators be inspected to determine the need to relubricate the actuator gear train. It is also recommended that the linkage rod ends be lubricated at this time to extend life.



CAUTION

Before removing the 11-400 from the gear reduction unit, block the actuator crank arm to prevent the crank arm and the gear train from moving when the 11-400 is removed.

Remove the assembly gear module. Remove the gears from their shafts and clean them thoroughly, removing all old lubrication.

Examine the gear teeth, shaft bore, and gear shafts for signs of excessive wear, scoring, or other damage. If evidence of this damage is present, the actuator should be returned to the factory for a detailed examination of the main gear, which requires complete disassembly of the actuator. See "HOW TO OBTAIN SERVICE" on page 43.

If there is no evidence of damage to the gearing, recoat the teeth and shaft bores of all gears with a heavy layer of Fiske Lubriplate GR-132 or equivalent. GR-132 is an E.P. grease with polymer additives and a temperature range of -40°F. to +350°F. The ball bearing on the output shaft and crown gear shaft have added, double grease seals and require no maintenance for the life of the bearings. Inspect all grease seals and replace any that show wear. Reassemble the actuator.



MAINTENANCE Component Replacement

This section covers replacement of many components of the 11-430 actuator. Note that some components are not field repairable. If it should ever be necessary to replace the output gear, shaft, or output shaft bearings, a major overhaul is required and the actuator should be returned to the factory.

GASKETS

During routine service, inspect removed cover gaskets for wear or damage. In order to protect internal components, worn or damaged gaskets and O-rings should be replaced.

To remove, scrape all of the old adhesive and gasket material from the body housing and cover, if necessary. Replacement gaskets are self-adhering, silicone rubber. Peel the backing off the replacement gasket and carefully apply to the actuator body.

SEALS

Worn or damaged output shaft, control end shaft, and motor shaft seals should be replaced to prevent damage to internal bearings and drive train parts.

To remove the shaft seal, push the blade of a small screwdriver along the shaft and under the seal lip. *NOTE: The seal is approximately 1/4" (6 mm) wide. Do not force the screwdriver blade beyond the width of the seal; damage to the shaft bearing could result.* Pry the seal out of the housing. Clean the shaft and housing, then press in the replacement seal with the closed side facing outward.

BEARINGS

The 11-400 actuator contains ball bearings on the output shaft, control end shaft and motor shaft. Bushings and thrust washers are used on combination gears. The gear reduction unit contains tapered roller bearings on the output shaft and ball bearings on the pinion shaft.

11-400 control end shaft ball bearings may be replaced by carefully pressing the bearing out of the retainer. When pressing the new bearing into the retainer, be certain the bearing inner and outer race are properly supported and the bearing is held perpendicular to the retainer.

Motor shaft ball bearings are not field replaceable. Disassembly of the motor will result in a loss of torque that can only be restored by returning the motor to the factory for remagnetizing.

The motor shaft bushing in the body of the 11-400 can be replaced. **TIP:** To remove, fill the bushing with a heavy grease. Select a drive pin that slip fits into the bushing. Insert the pin into the bushing and tap with a mallet. This will force the bushing out of the body casting.

Bushings on combination gears are not field replaceable. If this bushing is worn, the combination gear must be replaced.

MOTOR

The control motor is not field-repairable. Disassembly of the motor will result in a loss of torque that can only be restored by returning the motor to the factory for remagnetizing.



WARNING

Electrical shock hazard. Disconnect power before proceeding.



CAUTION

Before removing the control motor, block the actuator crank arm to prevent the crank arm and the gear train from moving when the motor is removed. Also, disconnect line voltage from actuator.

To remove the motor, first disconnect the motor wires in the terminal compartment of the actuator. The wiring is under the terminal board. Remove the terminal block and plate as an assembly. Remove the black wire from the terminal post, cut the green motor wire near the green-yellow-red butt joint and disconnect the red wire from the motor capacitor. Remove the mounting bolts and motor. Carefully slide the motor out of the actuator body.

To install the motor, insert the three-wire sleeve through the wire hole in the motor mount and into the terminal compartment. Carefully slide the motor into the actuator body, rotate the motor shaft if necessary to engage the pinion with the first combination gear. Install motor mounting bolts and torque to 16 lb-ft (22 N•m). Reconnect the motor wires.

See the following section for reinstalling the terminal plate.

MOTOR RESISTOR AND CAPACITOR



WARNING

Electrical shock hazard. Disconnect power before proceeding.

The motor resistor and capacitor are located under the terminals in the terminal compartment. To replace a resistor or capacitor, remove the terminal cover. Remove the terminal plate. Remove the existing part and transfer the wires one at a time to the replacement part. Inspect the terminal plate gasket and replace if necessary. To ensure a watertight seal between the plate and gasket, coat the gasket with a thin film of grease before replacing the terminal plate. Torque the screws to 3 lb-ft (4 N•m).

MAINTENANCE Component Replacement

LIMIT AND AUXILIARY SWITCHES



WARNING

Electrical shock hazard. Disconnect power before proceeding.

Complete switch assemblies may be replaced. It is not possible to replace individual switches. To replace switch assemblies, remove the control end cover (5/16" bolt heads) and extensions, if applicable. Remove the screws holding the switch assembly to the plate and slide it out to the side.

Transfer the wires one at a time to the replacement assembly using the push-on lugs provided. Install the replacement assembly and note that it rotates around one screw to permit an adjustment of the cam-to-switch lever spacing and switch operating point. To properly set the switch, use a .030" (.75 mm) shim between the cam and switch lever and loosely position the switch assembly so that the switch is just actuated. The switch lever should be on the low or minimum radius portion of the cam when setting the switches. DO NOT overstress the switch lever. Tighten both screws to 10 lb-in (1 N•m) torque and remove the shim. When properly adjusted, the switch lever should remain in contact with the cam throughout the actuator travel.

ADDING SWITCHES

It is usually possible to add switches to an actuator in the field. Remove the control end cover (5/16" bolt heads) and extensions, if applicable. If the actuator has no auxiliary switches, it is possible to add up to four more switches.

If the actuator shaft does not have unused switch cams, extra switches may be added but additional parts will be required. Consult the factory, giving the actuator model and serial number so that a correct list of parts required may be supplied to you.

Install wiring onto the switch push-on lugs and route the wires into the actuator terminal area. Remove the terminal cover and solder wires to the underside of the terminal assembly according to the wiring diagram included with the new switch assembly. Install the new switch assembly and adjust according to the instructions above. See Table 6, page 37, for switch part numbers.

SELF-LOCKING MECHANISM (SLM)

In normal service, the SLM friction surface should not require replacement; however, a combination of excessive modulation and load can cause wear to the SLM mechanism. If the SLM has been damaged, rebuild kits are available (see Table 5, page 32).

TABLE 5

Motor Part No.	SLM Rebuild Kit
20-2201-31, -32, -33	12-8067-13
20-2201-35	12-8067-14

SLM Rebuild Kits typically consist of friction material, spring, spring pin, thrust washer, pinion, steel balls, locking disc, steel shims, control motor gasket, terminal joints, slip-on terminal and instruction sheet.

See the illustration below for component identification.

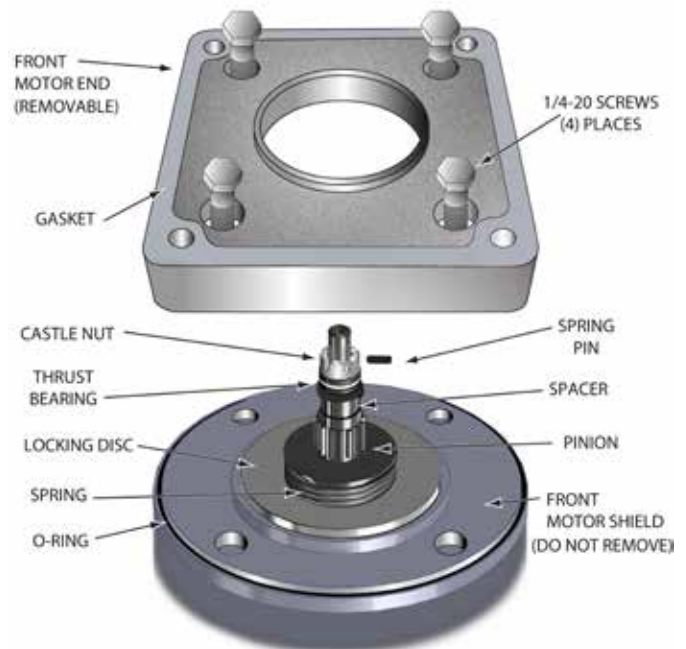

11-43_ SLM COMPONENTS

Figure 10

HANDSWITCH



WARNING

Electrical shock hazard. Disconnect power before proceeding.

To replace the Handswitch, remove the terminal cover, then remove the terminal plate. Clip the five wires from the old Handswitch. Remove the knob and the nut under the knob to remove the switch. Install the new Handswitch as shown in Figure 11. Splice wires color for color. Inspect the terminal plate gasket and replace if necessary. To ensure a watertight seal between the plate and gasket, coat the gasket with a thin film of grease before replacing the terminal plate. Torque screws to 3 lb-ft (4 N•m). Do not over torque. Replace the terminal cover. Torque bolts to 10 lb-ft (14 N•m).

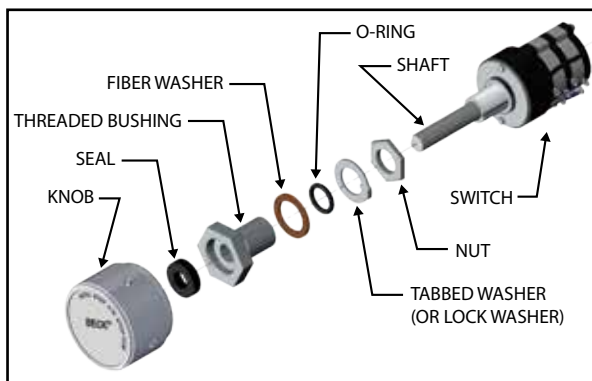

HANDSWITCH COMPONENTS

Figure 11

FUSE (F1) REPLACEMENT (FOR ACTUATORS EQUIPPED WITH OPTIONAL 208V OR HIGHER POWER SUPPLY)



WARNING

Electrical shock hazard. Disconnect power before proceeding.

Remove the terminal block cover. Locate the fuse holder (similar to the illustration below).

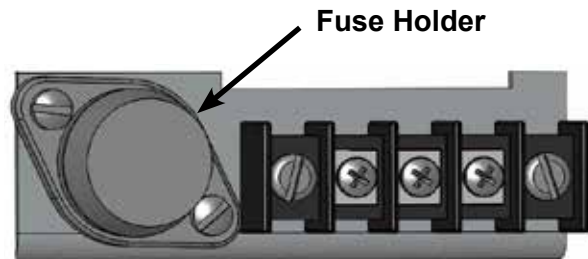

Turn the fuse holder CCW while pressing down. The fuse holder should spring loose when free. Remove the fuse holder from the actuator. Pull the fuse free from the holder. Replace the fuse with the same type (see table below) by pushing it into place.

Reinsert the fuse holder into the actuator. Turn the fuse holder CW while pressing down to tighten. Replace the terminal block cover. Tighten the cover screws to 6 lb-ft (8 N•m) torque.

REPLACEMENT FUSES (F1)

Input Voltage	Amps	Volts	Type	Part No.
208	3.2	250	Time Delay	11-1370-25
240	3.2	250	Time Delay	11-1370-25
380	1.8	600	Time Delay	11-1372-32
415	1.6	600	Time Delay	11-1372-31
480	1.4	600	Time Delay	11-1372-30
575	1.25	600	Time Delay	11-1372-29

MAINTENANCE Component Replacement

RELAY BOARDS

The Relay Boards (13-2246-50 & 13-2246-51) are not field repairable and must be replaced if there is an issue.



WARNING

Electrical shock hazard. Disconnect power before proceeding.

To replace a Relay Board, remove the Relay Board compartment cover (four captive, 5/16" hex head screws). Loosen the four captive screws holding the board to its mounting pads. Note the "L" shaped mounting bracket on the end of the board. To remove the board, pull the mounting bracket away from its mating surface and connector receptacle, using a gentle, rocking motion.

To install a Relay Board, lightly press the board connector into its receptacle until the mounting bracket is flush with its mating surface. Tighten the four captive screws to 8 lb-in (0.9 N•m). Replace the Relay Board compartment cover and tighten the cover screws to 10 lb-ft (14 N•m) of torque.

CPS-5

Field repair of the CPS-5 assembly is not recommended.



WARNING

Electrical shock hazard. Disconnect power before replacing the CPS-5.

If it is necessary to replace the CPS-5, replace the entire assembly (both sides). See page 34. When returning the CPS-5 to the factory for service, include the rotor and stator / circuit board assembly. Do not separate the stator or circuit boards from their mounting plates. It is recommended that the rotor be held inside the stator with rubber bands and the hex studs be reattached to the mounting plate for protection during shipment.

To remove the CPS-5:

1. Run the actuator to its midpoint of travel with the local Handswitch. (If the standard rotation of 100° has been reduced to 80°, the midpoint of travel is 40°.)
2. Disconnect 120 V ac power to the actuator. Remove the terminal compartment and control end covers (5/16" bolt heads).

3. Record the wire colors on the terminal block of the CPS-5 (see Figure 5, page 29), then disconnect the wires. The terminals are spring-loaded. To remove a wire, insert a 3/32" screwdriver in the slot above the wire. Rock the screwdriver away from the wire to open the spring-loaded contact and release the wire.
4. Loosen and remove the 3 hex studs that clamp the CPS-5 in place. Support the inboard hex stud with a wrench as the outboard stud is loosened.
5. Slide the CPS-5 stator assembly off the three mounting bolts.
7. Note the position of the rotor clamp, then loosen the rotor clamp screw and remove the rotor from the shaft.

To install the new CPS-5:

1. Remove the rotor from the replacement CPS-5 assembly. Slide the rotor, clamp end first, onto the control shaft as close to the mounting plate as possible. Leave the clamp loose. Position the clamp in the same general location as the one removed previously.
2. Slide the new CPS-5 assembly over the studs and rotor. Replace the hex nuts but do not tighten. Carefully slide the rotor back into the CPS-5 assembly. Twist the rotor while sliding to prevent damage to the assembly. Tighten hex nuts to 5 lb-ft (7 N•m).
3. Thread the wires through the wire holes in the CPS-5 and reconnect them to the terminal block.
4. Restore 120 V ac power to the actuator and connect a meter to the output.
Record the color and location of the feedback signal wires for reconnection later. Remove the two feedback wires. Connect a mA meter in series with a 200 ohm load resistor.
5. Insert a 0.031" (.8 mm) feeler gauge between the rotor clamp and stator. Position the clamp 0.031" (.8 mm) from the stator.
6. Rotate the rotor on the control shaft until the output on the mA or voltmeter reads 50% of signal span, then tighten the clamp to 5 lb-in (.6 N•m) torque.
7. Check the feedback signal calibration as described on page 25.

MAINTENANCE Troubleshooting

If your unit contains a Stall Protection Module (SPM) refer to publication 80-0017-03, page 7, "Troubleshooting".

CONDITIONS	POSSIBLE CAUSES	CORRECTIONS
Actuator runs in only one direction in AUTO and both directions with Handswitch on CW and CCW.	Handswitch failure.	Check continuity from terminal N to V and M to U with Handswitch in AUTO. See wiring diagram.
	Jumper between F-N or D-M not connected.	Connect jumper.
Actuator runs in the wrong direction with input signal applied.	Input signal reversed.	Check polarity of input signal. Terminal AA(+), terminal BB(-).
	Actuator configured for wrong direction of travel.	Change direction of rotation.
Actuator does not follow input signal until maximum or minimum signal is reached, then drives uncontrollably to limit.	Wire jumpers on terminals M and N are reversed or potentiometer end connections are reversed.	Change direction of shaft rotation. Check correct film potentiometer connections.
Actuator motor oscillates in AUTO mode.	Feedback potentiometer dirty.	Clean or replace potentiometer.
	Physical obstruction (e.g., valve jammed or load greatly exceeds rating of actuator).	Check operation with Handswitch and remove obstruction if present.
	Excessive wear in gear train or bearings.	Replace worn drive train parts.
Actuator motor erratic or runs in wrong direction in automatic or manual operation.	Control motor winding open.	Replace control motor.
	Control motor capacitor shorted or open.	Replace capacitor.
	Control motor resistor open.	Replace resistor.
Actuator will not run in either direction or one direction in automatic or manual operation.	Limit switch failure.	Replace limit switch.
	Handswitch failure.	Replace Handswitch.
Actuator runs erratic from 100° to 0° and runs normally from 0° to 100° in AUTO.	Feedback potentiometer dirty. Loss of feedback voltage drives the unit towards the 100% limit.	Clean feedback potentiometer with mild soap and water.
Actuator runs uncontrollably to some position, then oscillates.	Feedback potentiometer open.	Replace feedback potentiometer.
Actuator does not stop at normal or desired limit of shaft travel.	Limit switches adjusted incorrectly.	Readjust limit switches.
	Limit switch failure.	Replace limit switch.
	CPS-5 calibration incorrect.	Calibrate CPS-5.
Loss of input signal feature does not function.	Incorrectly set potentiometer.	Reset potentiometer.
	CPS-5 calibration incorrect.	Calibrate CPS-5.
Actuator drives to 100% limit with small change in input signal.	Feedback potentiometer power supply shorted.	Check potentiometer and wiring for shorts.
	Wiper and low end of feedback potentiometer reversed.	Check wiring on feedback potentiometer for proper connections.
	Open potentiometer element.	Replace potentiometer.
	CPS-5 feedback out of phase with control motor.	Restore proper phasing of CPS-5 feedback w/control motor.
Actuator drives to 100% and stays.	Handswitch left in CW / CCW position.	Return Handswitch to AUTO position.
	Potentiometer open or complete loss of contact with wiper.	Check potentiometer and replace if necessary.
	CPS-5 feedback out of phase with control motor.	Restore proper phasing of CPS-5 feedback with control motor.
	Jumper between terminal F-N (F-M) not connected.	Connect jumper.
	CCW / CW limit switch failure.	Replace limit switch.

MAINTENANCE Troubleshooting

CONDITIONS	POSSIBLE CAUSES	CORRECTIONS
Actuator travel very non-linear: •e.g., 4–19 mA change on input causes actuator to drive from 0% to 30%; 19–20 mA change drives 30% to 100%. •Response normal from zero to mid-range, then runs to 100%.	Wiper and high end of feedback potentiometer reversed.	Check feedback potentiometer for proper connections.
CPS-5 LED goes out during normal travel.	CPS-5 power supply failure.	Check CPS-5 power supply voltage. See below.
Potentiometer or CPS-5 output decreases when it should increase.	CPS-5 rotor position not set for proper rotation. End connections on potentiometer reversed.	Reset CPS-5 rotor position. Calibrate potentiometer.
CPS-5 output non-linear.	CPS-5 rotor position not set properly. CPS-5 zero potentiometer improperly adjusted.	Reset CPS-5 rotor position. Refer to factory.
CPS-5 output does not reach maximum signal, but low end calibration is correct.	Output is overloaded: •load resistance is too low for voltage range. •load resistance is too high for current range. Low voltage: • CPS-5 power failure.	Check load resistance against suggested feedback signal terminal hook-up. Check line voltage at CPS-5 transformer terminals 1 and 3. Check CPS-5 voltage at resistor. Check CPS-5 power supply voltage across capacitors C8 (13 V, except -05.15 V), C9 (15 V), C10 and C11 (28 V).
CPS-5 out of calibration.	CPS-5 rotor not properly set. CPS-5 zero potentiometer not properly adjusted.	Reset CPS-5 rotor position. Refer to factory.
CPS-5 signal will not calibrate down to 4 mA.	CPS-5 zero potentiometer inadvertently reset.	Refer to factory.
Actuator does not stay in place with power off.	Not enough load on meter circuit. Unit being calibrated for less than 80° rotation.	Connect 200 ohm resistor in series with meter. Remove R8.
Actuator does not stay in place with power off.	SLM friction surface worn.	Replace SLM friction surface.
Control motor runs but output shaft does not move in one or both directions.	SLM failure.	Replace control motor.
Actuator equipped with modulating option 5 or 6 and an optional relay board does not run reliably in one or both directions while in AUTO.	Controller output requires a greater holding current than the relay board draws.	Check the controller output required AC holding current. If greater than 10 mA, additional load must be provided.

APPENDIX Spare Parts

RECOMMENDED SPARE PARTS

It is recommended that certain replacement parts be stocked for quick availability in the event that service of your Beck actuator is required. The types of parts are listed in Table 6, below.

HOW TO ORDER SPARE PARTS

Select the needed spare parts from Table 6, below. Specify the drive's model / serial number (example: 11-436-031891-01-02) given on the nameplate to allow the factory to verify part selection. Parts may be ordered by mail, telephone or fax, with the confirming order sent to the factory (see back cover).

**TABLE 6:
RECOMMENDED SPARE PARTS**

Description	Part Number	Description	Part Number
Relay board (option 5 & 6 only)	See Table 1, p.10	Fuse (F1) w/ operating voltage >120 V	See page 33
Fuse, 6A, 250V	13-2230-03	Limit switch assy. (CW / CCW)	20-3202-10
CPS-5 assembly (option 6 only)	See Table 1, p.10	Auxiliary switch assy. 2 switches (S1-S2)	20-3202-11
Control motor	See Table 7, below	4 switches (S1-S4)	20-3202-12
Motor resistor	See Table 7, below	Film potentiometer (option 5 only)	20-3060-03
Motor capacitor	See Table 7, below	Gasket kit	20-3110-03

**TABLE 7:
MOTORS^a, RESISTORS, & CAPACITORS**

Motor					Capacitor		Resistor	
Part Number*	Current (Amps at 120 V ac, 60 Hz ^c)	Torque (N·m)	RPM	Freq. (Hertz)	Part Number	Value (µf)	Part Number	Value (Ω)
20-2201-32	2.3	14.0	72	60	14-2840-15	25	20-1971-04	37.5 ^b
				50	14-2840-05 14-2840-15	8 25	20-1971-04	37.5 ^b
20-2201-33	3.0	14.0	120	60	14-2840-15 14-2840-09	25 6	20-1971-06	18 ^b
				50	14-2840-15 14-2840-05 14-2840-09	25 8 6	20-1971-10	24 ^b

^aAll motors listed are rated 120 V ac regardless of operating voltages using optional transformers.

^bThis is a resistor assembly.

^c50 Hz currents do not exceed 120% of the 60 Hz levels.

*Note that motor replacement part numbers will include the suffix "KIT"; e.g., 20-2201-32-KIT.

**TABLE 8:
MODEL 11-400 GEARS**

Spur Gearing Ratio / 1	Stroking Speed (sec./100°)			Gear Part Number		
	Motor					
	20-2201-23, -33	20-2201-22, -32		Gear Module Gear Set*	Output Shaft Assembly	Third Comb. Gear
	60 Hz 120 RPM	60 Hz 72 RPM	50 Hz 60 RPM			
756	108	180	216	14-9732-02	14-9872-10	14-9692-03
525	72	120	144	14-9732-07	14-9872-10	14-9692-03

*Note that gear module replacement part numbers will include the suffix "KIT"; e.g., 14-9732-02-KIT.

APPENDIX Component Detail

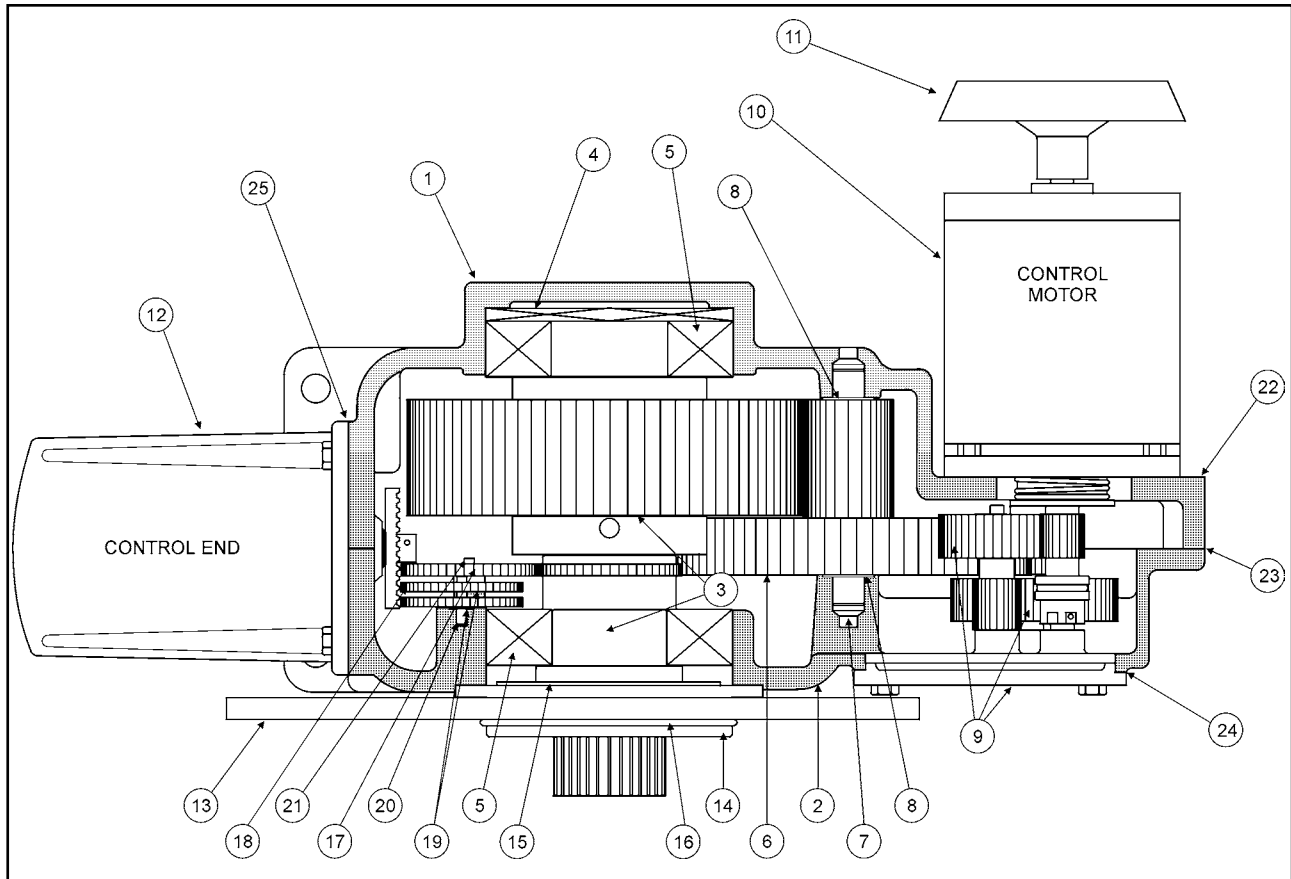

**TABLE 9:
ACTUATOR COMPONENTS***

Item No.	Description	Item No.	Description
1	Body rear	13	Adaptor plate
2	Body front	14	Sleeve, pilot tube
3	Output shaft assembly with main gear	15	Gasket, sleeve, pilot tube
4	Spring washer	16	O-ring
5	Ball bearings, output shaft	17	Spur gear, 1st combination
6	Gear, 3rd combination	18	Spur gear, 2nd combination
7	Pin, 3rd combination gear	19	Washers, flat fiber
8	Thrust washers	20	Pin, 2nd combination spur gear
9	Gear module assembly, see Table 8, p.37	21	Pin, 1st combination spur gear
10	Control motor, see Table 8, p.37	22	Gasket, control motor
11	Handwheel, 6 1/2" O.D.	23	Gasket, body
12	Control end cover	24	Gasket, change gear plate
		25	Gasket, control end cover

*To ensure exact replacement parts, include all nameplate data from the actuator with your order.

APPENDIX CPS-5 Data

**TABLE 10:
CPS-5 SYSTEM APPLICATION DATA SUMMARY**

FEEDBACK SIGNAL OPTIONS	CPS-5 MODEL NUMBERS	EXTERNAL LOAD RESISTANCE	COMPATIBLE CONTROL SYSTEMS
<u>Current Signals</u>			
4 to 20 mA	20-4400-02	800Ω (Max.) 500Ω (Max.)	Industry Std (ISA)

**TABLE 11:
CPS-5 SIGNAL OUTPUT TERMINAL CONNECTIONS AND LOADING**

SIGNAL RANGE	OUTPUT TERMINALS (+) (-)	RANGING RESISTOR		RESISTOR CONNECTIONS	MAXIMUM EXTERNAL LOAD
		VALUE	BECK PART NO.		
Models 20-4400-02					
4 to 20 mA	EE—CC	Open			800Ω
4 to 20 mA	EE—DD	Open			500Ω

APPENDIX CPS-5 Functional Block Diagram

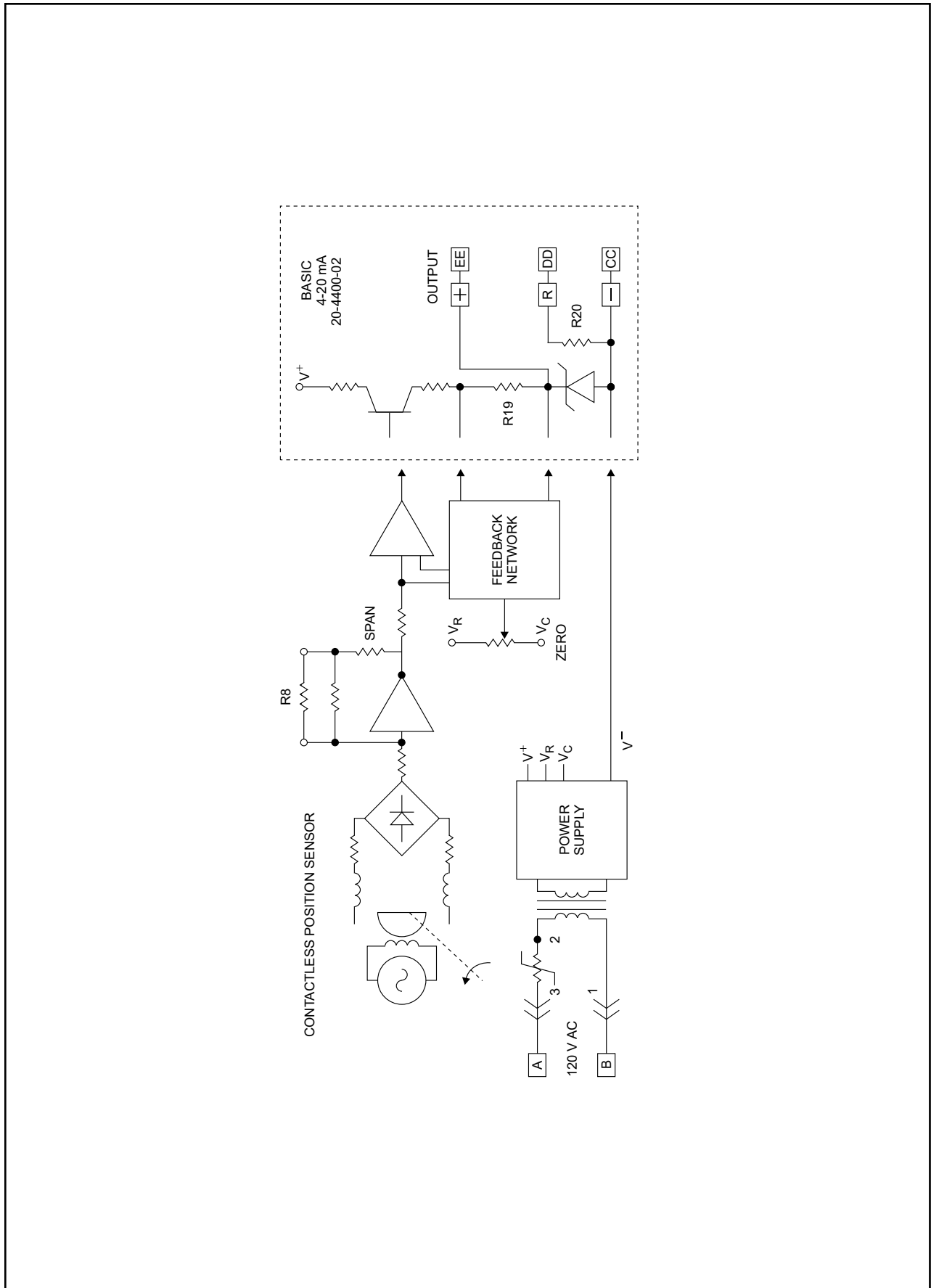

APPENDIX *Optional LED Display*

The optional LED display board (p/n 22-5008-51) for open/close and AC-pulsed Beck actuators (Control option 3 through 6) provides lighted color indication of the actuator output position. The board resides in the same location (the electronics compartment) as that of the optional DCM display board available with 4–20 mA modulating actuators (control option 9). The same compartment cover with a tempered glass window is used with all versions.

This display board includes a red, green and yellow LED to indicate the actuator output position. The lights are driven by 120 V ac actuator power and are energized using the actuator's internal auxiliary switches.

The red and green LEDs, which are intended to indicate OPEN and CLOSE ends-of-travel are easily setup by connecting jumpers on the actuator's terminal block (see the wiring diagram below).

The yellow LED will light whenever both the red or green LED are not lit (when the actuator is not at either end-of-travel limit). If desired, the yellow LED may be turned off with a slide switch located on the board (see image below).

The red LED will light when the output shaft has rotated to the CCW travel limit, and the green LED will light after rotation to the CW travel limit (default setting). To reverse these LEDs (red = CW, green = CCW), a toggle switch is located on the board (see image below).

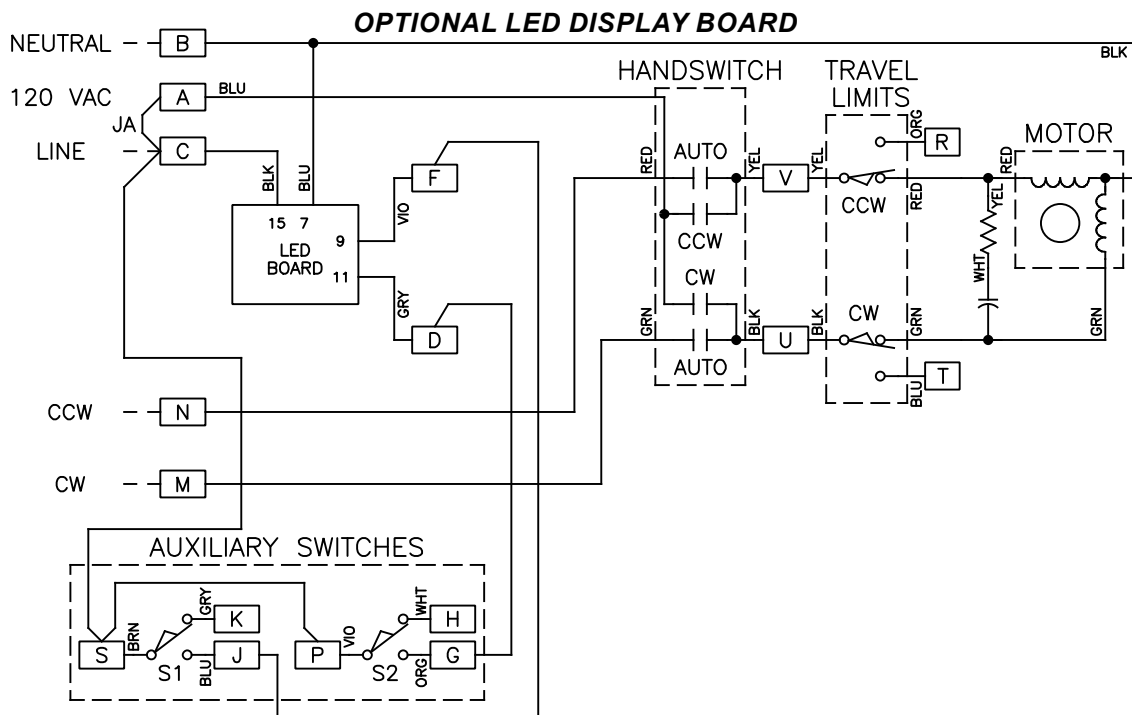
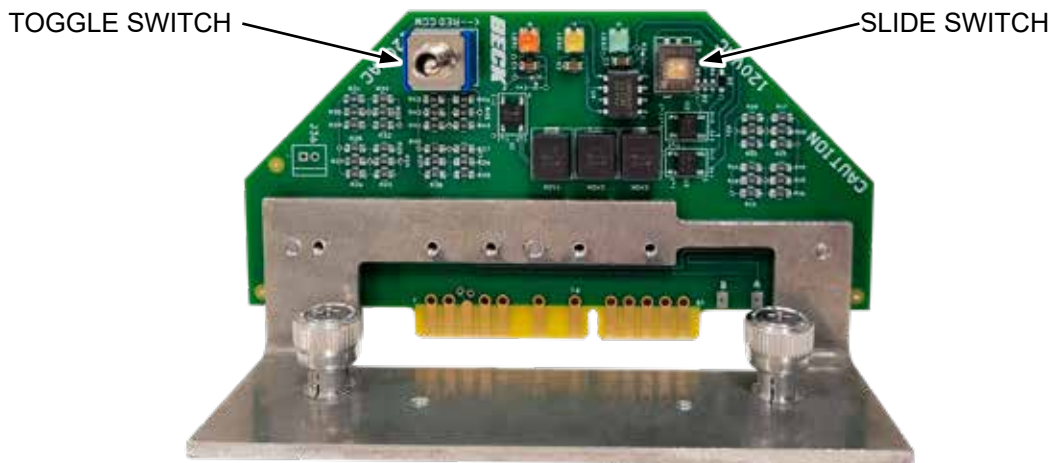

TYPICAL WIRING DIAGRAM WITH TWO AUXILIARY SWITCHES

INDEX

Actuator components.....	38	Product demonstrations.....	43
Application reviews.....	43	Product description.....	4
Bearings, replacement.....	31	Relay board.....	28–29
Block diagram, CPS-5.....	44	Self-Locking Mechanism (SLM).....	18, 32
CPS-5 calibration.....	27	Safety precautions.....	11
CPS-5 functional block diagram.....	40	Seals, replacement.....	31
CPS-5 output terminal connections & loading..	39	Service, how to obtain.....	43
CPS-5 replacement.....	34	Site surveys.....	43
CPS-5 system application data summary.....	39	Spare parts, recommended.....	37
CPS-5 signal connections.....	15	Specifications.....	6
Changing direction of output shaft rotation.....	23	Specification writing.....	43
Changing the mounting orientation.....	12	Stall protection.....	20
Contactless Position Sensor (CPS-5).....	19	Start-up instructions.....	16
Control motor.....	18	Storage information.....	11
Control options.....	10, 19	Switch adjustments.....	21
Demand signal (Relay Board) calibration.....	28	Switches.....	21
Electrical schematic.....	20	Switches, adding / replacement.....	32
Feedback signal calibration.....	25	Table of contents.....	3
Film potentiometer.....	20	Troubleshooting.....	35
Film potentiometer calibration.....	25	Unpacking.....	11
Gaskets, replacement.....	31		
Gear components.....	38		
Gear train.....	18		
General specifications.....	6		
Handswitch.....	18		
Handswitch, replacement.....	33		
Handwheel.....	18		
Housing.....	18		
Installation.....	11		
Introduction.....	2		
Linkage.....	5, 16–17		
Lubrication.....	30		
Maintenance.....	30		
Component replacement.....	31		
Routine.....	30		
Motor, replacement.....	31		
Motor resistor and capacitor, replacement.....	31		
Orientation options.....	12		
Outline dimension drawings.....	8		
Position feedback.....	20		

SERVICES

PRODUCT DEMONSTRATIONS

Each of Beck's Sales Engineers has access to a complete set of actuator models so that he can demonstrate virtually any of their features at your location. In order to arrange to see a Beck actuator in your plant or office, contact Beck's Sales Department.

SITE SURVEYS

Beck Sales Engineers are available to discuss your process control requirements. Often a visit to your location is the best way to gain a thorough understanding of your needs, in order to meet them most accurately and completely.

Mounting hardware, torque requirements, linkage, control signal information, and optional equipment can be analyzed most effectively at the worksite. Beck's analysis at the jobsite can help ensure that specifications are accurate, especially in the case of complex applications.

APPLICATION REVIEWS

By sharing your needs with a Beck Sales Engineer you can take advantage of the best application advice for the type of control you need.

This review will yield a better understanding of the versatility of Beck drives for your installations, as well as complete details on options and accessories to make the process as effective as possible.

SPECIFICATION WRITING

Beck provides specification writing assistance in order to help you specify and order the right drives for your applications. Beck Sales Engineers will work with you to make it easier for you to obtain the proper equipment and give you confidence that no details are overlooked.

HOW TO OBTAIN SERVICE

Factory repair of drives or subassemblies is available for both normal and emergency service. To assure prompt processing, contact the factory to receive a Returned Material Authorization (RMA) number. If a repair estimation is desired, please send the name and phone number of your contact for service authorization. It is helpful to include a description of the work desired with the shipment or, in the event of a problem, the malfunction being experienced.

THREE YEAR LIMITED EQUIPMENT WARRANTY

Beck warrants to Buyer that: (i) for a period of 3 years from the date of shipment, the Equipment manufactured by Beck shall materially conform to Beck's published standard specifications in effect as of the date of shipment; and (ii) the Beck Equipment will be free from defects in materials and workmanship. This warranty does not apply to normal wear and tear, or where Beck Equipment failure is a result of improper installation, improper storage, misuse or improper maintenance, or water ingress related to Buyer or its agents failing to apply the stated torque requirements to fasteners when attaching covers or failing to replace temporary conduit plugs as stated in the installation instructions, or entry through conduits.

During the Limited Warranty Period, Buyer shall notify Beck of any alleged warranty claim within 30 days from the date Buyer discovers, or upon reasonable inspection should have discovered, such alleged claim (but in any event prior to the end of the Limited Warranty Period), and Buyer shall return the Beck Equipment in question, at Buyer's expense, to Beck for evaluation, in compliance with the terms stated in the "Return of Equipment" article in the Sales Contract. If Beck determines that the Beck Equipment fails to conform to the limited warranty, then, at Beck's sole discretion and its expense (subject to Buyer's conformity with the warranty), Beck will either: (i) repair or replace the Beck Equipment, without charge, at Beck's factory, or (ii) refund the purchase price of such Beck Equipment, less any applicable discounts, rebates, or credits. In no event will Beck's liability exceed the contract price actually paid for such Beck Equipment subject to a warranty claim. Beck makes no warranty, express or implied, with respect to any Buyout Item. This limited warranty is not transferable or assignable to any transferees of the Beck Equipment.

THIS WARRANTY IS EXPRESSLY IN LIEU OF ANY OTHER EXPRESS OR IMPLIED WARRANTY, INCLUDING IMPLIED WARRANTIES OF MERCHANTABILITY AND FITNESS FOR A PARTICULAR PURPOSE, AND ALL OTHER OBLIGATIONS OR LIABILITIES OF BECK. BUYER ACKNOWLEDGES THAT: (i) BECK HAS MADE NO INDEPENDENT INVESTIGATION OF THE SUITABILITY OF THE EQUIPMENT FOR BUYER'S INTENDED USE OR EXISTING SYSTEMS; AND (ii) BUYER HAS NOT RELIED UPON ANY REPRESENTATION OR WARRANTY MADE BY BECK OR ANY OTHER PERSON ON BECK'S BEHALF, EXCEPT AS SPECIFICALLY PROVIDED IN THE SALES CONTRACT. THIS SECTION SETS FORTH BUYER'S SOLE AND EXCLUSIVE REMEDY FOR ANY BREACH OF THE LIMITED WARRANTY SET FORTH IN THIS SECTION.

A 100% EMPLOYEE OWNED COMPANY

BECK

- founded 1936 -

SINCE 2021



HAROLD BECK & SONS, INC.

11 TERRY DRIVE • NEWTOWN, PENNSYLVANIA 18940 • USA

PHONE: 215-968-4600 • FAX: 215-860-6383 • E-MAIL: sales@haroldbeck.com

www.haroldbeck.com

Made in USA

