

BECK®

INSTRUCTION MANUAL

For actuators equipped with the
DCM-3 (built after July 2016)

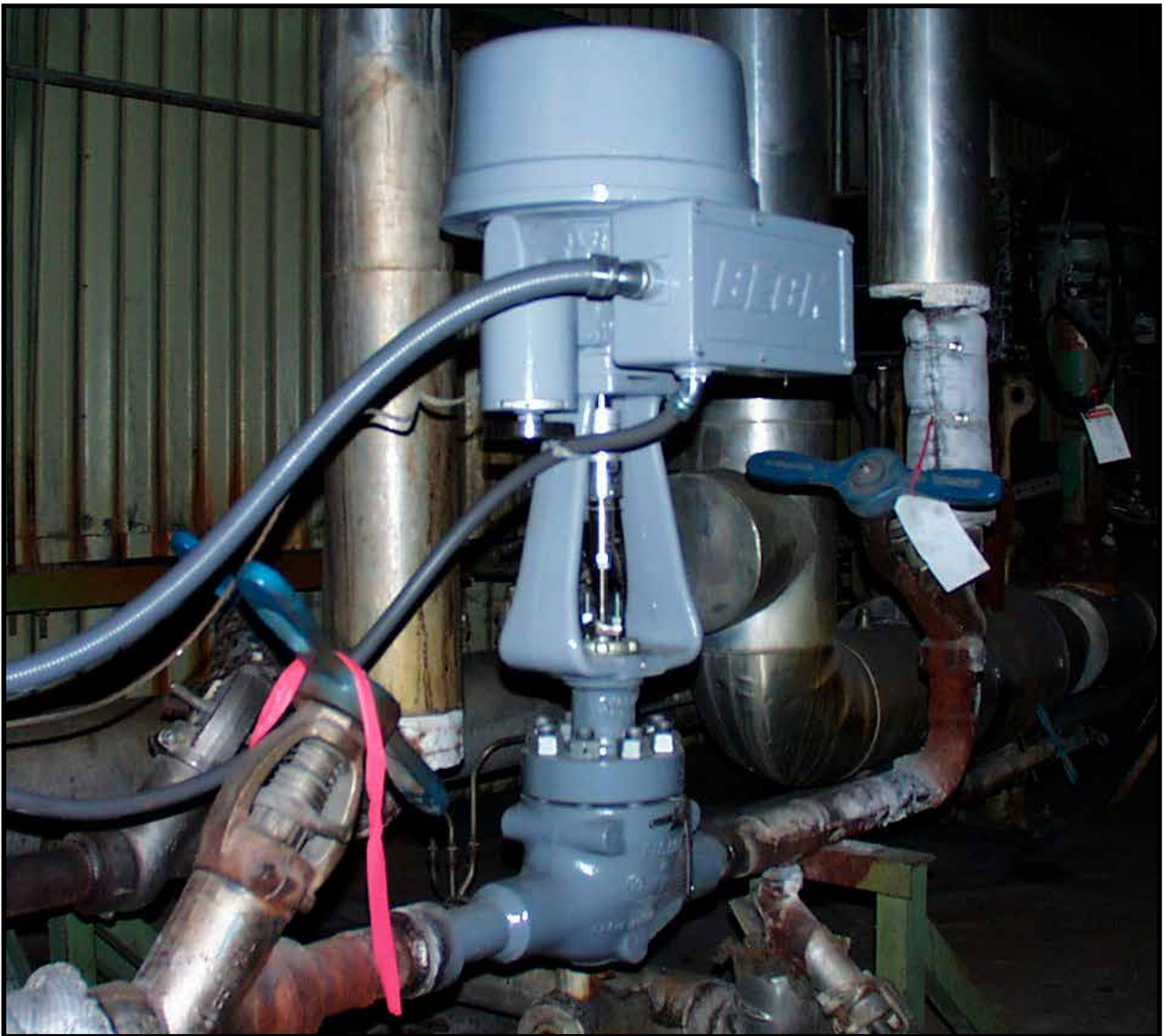

INTRODUCTION / TABLE OF CONTENTS

This manual contains the information needed to install, operate and maintain Beck Model Group 14 Electric Actuators equipped with the Digital Control Module (DCM-3), manufactured by Harold Beck & Sons, Inc. of Newtown, Pennsylvania.

The Group 14 linear actuator is a powerful control package designed to provide precise position control of globe valves and other devices requiring up to 1,800 lbs (8010 N) of thrust.



NOTICE: This manual contains information that will make installation simple, efficient and trouble-free. Please read and understand the appropriate sections in this manual before attempting to install or operate your actuator.

Introduction	2
General Specifications	3
Outline Dimension Drawings	5
Precautionary Information	6
General Operation Information	7
Installation	8
Mechanical	8
Electrical	9
Wiring	10
Start-up	11
Components	12
Mechanical	12
Electronics	14
Configuration/Calibration	18
Maintenance	34
Troubleshooting	42
Appendices	47
HART® Communication	47
HART® Messages	53
Serial Communication	56
Serial Commands	57
Optional DCM-3 with Feedback Display	64
Index	66
Services	67

GENERAL SPECIFICATIONS

Actuator Power	120 V ac, single-phase, 60 Hz (Standard), 50 Hz (Optional) 48, 72 or 180 watts 240 V ac, 50 or 60 Hz (Optional)	Allowable Tolerance	+10% -15%
Model	Maximum Current and Power		
	120 V ac		240 V ac
14-109	.56 A	72 W	.33 A 80 W
Operating Conditions	-40° to 85°C (-40° to 185°F) 0 to 100% relative humidity, non-condensing		
Communication Interface	HART protocol (Rev. 5 -- burst mode is not supported) Pushbutton/LEDs DB9 Serial commands		
Demand Input Signal Options	4–20 mA (1–5 V dc input is possible with the removal of the “R11” resistor located on the DCM-3 board (see page 37 for location)		
Adjustability for Split Range Operation	0%: 0.1 V to 4 V dc 100%: 0% + 1 V min. to 5 V max.		
Minimum Step Size	0.1% (0.15% typical, configurable from 0.1 to 2.5%)		
Linearity	±1% of span, max. independent error		
Hysteresis	0.25% of span at any point		
Demand input Signal Characterization	<p>Linear: Actuator output shaft moves proportionally to the input signal</p> <p>Square: Actuator output shaft moves proportionally to the square of the input signal</p> <p>Square Root: Actuator output shaft moves proportionally to the square root of the input signal</p> <p>Custom: Actuator output shaft moves according to the configurable 10-segment response curve</p>		
Position Feedback Signal	4–20 mA		
Isolation	Demand input and position Feedback signals are isolated from ground and the AC power line. Signal buffering provides 24 V dc isolation between the Demand and Feedback signals		
Action on Loss of Power	Stays in place		
Action on Loss of Input Signal	Stays in place or actuators to any preset position (configurable)		
Stall Protection	If the motor tries to run in one direction for more than 300 seconds (configurable from 30 to 450 seconds), the DCM-3 will shut off power to the motor (feature can be enabled/disabled) - factory default is enabled.		
Alarm Annunciation	Available at terminal E.		

GENERAL SPECIFICATIONS

Temperature Indication	Measures the internal temperature of the actuator and triggers an alarm when the temperature exceeds the rating.
Over-travel Limit Switches	Two SPDT switches (Retract and Extend) provide over-travel protection.
Auxiliary Switches	Two 6 A, 120 V ac switches are provided (S1 & S2) and two additional switches (S3 & S4) are available. All switches are cam-operated and field-adjustable.
Handswitch	Permits local electrical operation, independent of controller signal. Standard on all units. An auxiliary contact is available as an option for remote auto indication (rated 2.5 A at 120 V ac).
Handwheel	Provides manual operation without electrical power.
Motor Assembly	120 V ac, single-phase, no-burnout, non-coasting motor has instant magnetic braking. Requires no contacts or moving parts.
Gear Train	High-efficiency, precision-cut, heat-treated alloy steel and ductile iron gears and bronze nut. Interchangeable gear modules permit field change of timing.
Mechanical Stops	Prevent overtravel during automatic or manual operation.
Enclosure	Precision-machined, aluminum alloy castings painted with corrosion-resistant polyurethane paint provide a rugged, dust-tight, weatherproof enclosure. Type 4; IP66.
Stroke Adjustment	Calibar simultaneously adjusts the stroke length, position feedback signal, over-travel limit switches and auxiliary switches. The new stroke displacement is produced by the full input signal.
Mounting Orientation	Any orientation—no limitations.
Standards*	CSA Labeled (US & Canada); CE Compliant; UKCA Compliant

*NOTE: May not be available with all options and models. For more information, please call Beck at 215-968-4600.

Basic Model	Thrust (lbs. / N)	Timing -- sec./in. (sec./cm.)				Dimensional Data
		@ 60 Hz		@ 50 Hz		
14-100	340 / 1513	4	(1.6)	5	(2)	Page 5
	425 / 1891	11	(4.3)	13	(5.1)	
	600 / 2670	16	(6.3)	19	(7.5)	
	650 / 2893	8	(3.1)	10	(3.9)	
	800 / 3560	11	(4.3)	13	(5.1)	
	1,000 / 4450	27	(10.6)	32	(12.6)	
	1,100 / 4895	16	(6.3)	19	(7.5)	
	1,620 / 7209	48	(18.9)	57	(22.4)	
	1,800 / 8010	27	(10.6)	32	(12.6)	

OUTLINE DIMENSION DRAWINGS

5/16 [8] to 2 1/8 [54] travel

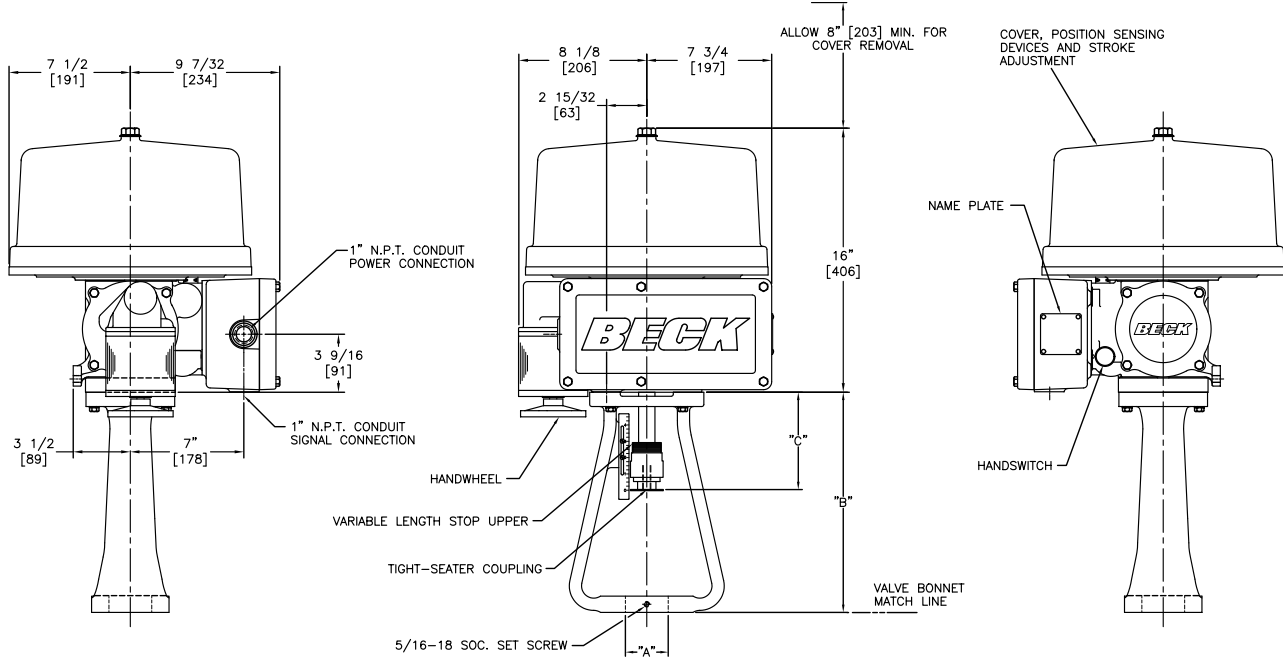

3/4 [19] to 4 1/2 [114] travel

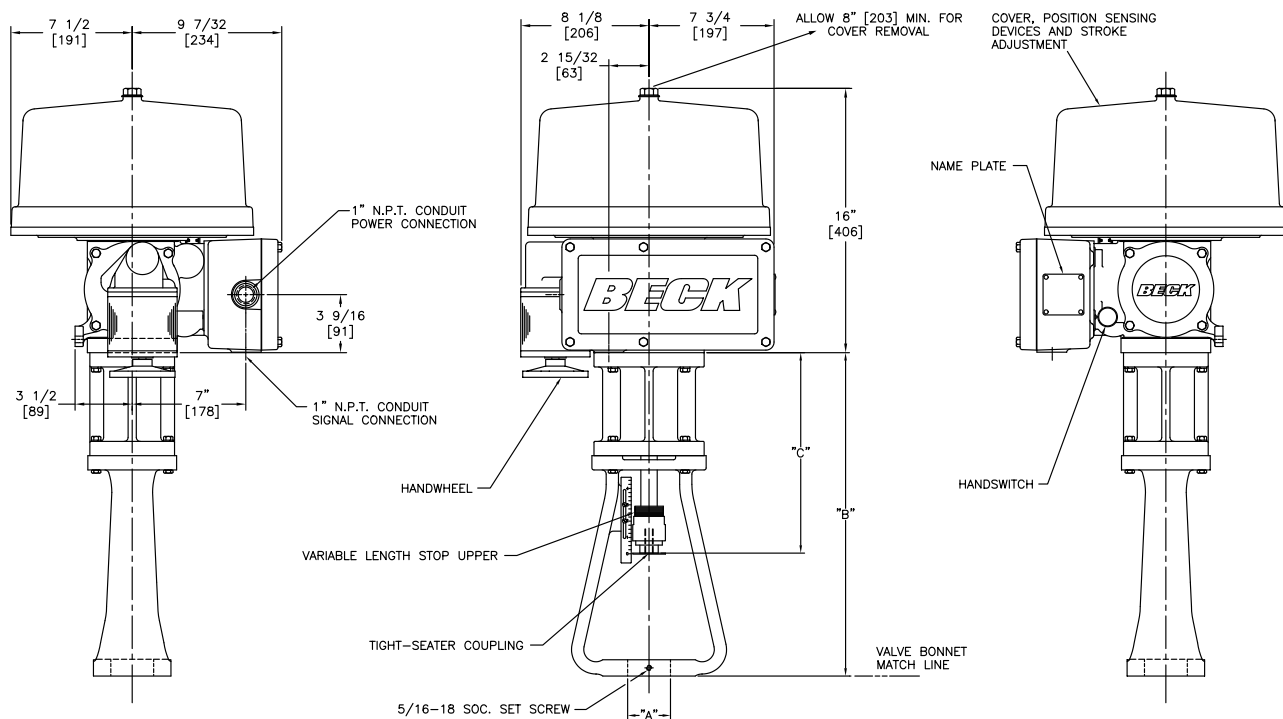

NOTE: Actuators may be mounted in any orientation. Dimensions in inches & [mm].

Drive Shaft Travel Range (in) [mm]	"A" Valve Boss Dia. Range (in) [mm]	"B" Yoke Height (in) [mm]	"C" Nominal Drive Shaft Extension (in) [mm]	Max. Valve Stem Extension (Valve Stem Retracted) (in) [mm]	Approx. Weight (lb) [kg]
5/16-1 3/4 [8-44]	1-2 5/8 [25-67]	8 [203]	4 3/16 [106]	5 1/2 [140]	80 [36]
3/4-2 1/8 [19-54]	1 3/8-3 3/4 [35-95]	13 1/2 [343]	6 [152]	9 1/4 [235]	92 [42]
3/4-3 1/2 [19-89]	1 3/8-3 3/4 [35-95]	19 13/16 [503]	12 5/16 [313]	9 1/4 [235]	100 [45]
1 3/4-4 1/2 [44-114]	1 3/8-3 3/4 [35-95]	19 13/16 [503]	12 5/16 [313]	9 1/4 [235]	100 [45]

PRECAUTIONARY INFORMATION

SAFETY PRECAUTIONS



WARNING

Installation and service instructions are for use by qualified personnel only. To avoid injury and electric shock, do not perform any servicing other than that contained in this manual. Please read and understand the appropriate sections in this manual before attempting to install or operate your actuator.

STORAGE INFORMATION

Beck actuators should be stored in a clean, dry area where the temperature is between -40° and 85°C (-40° to 185°F).

Damage due to moisture while in storage is not covered by warranty.

INSTALLATION—MECHANICAL

There are many considerations regarding proper mechanical installation—see the instructions beginning on page 8 for details. Refer to the outline dimension drawings on page 5 for physical dimensions and required clearances.

VALVE ACTUATOR INSTALLATIONS



CAUTION

Working with valves installed in a pipeline can be dangerous. Take appropriate precautions when mounting to installed valves.

INSTALLATION—ELECTRICAL

See the instructions beginning on page 9 for details regarding electrical installation.



CAUTION

For maximum safety, the Beck actuator body should be grounded. Use the green grounding screw in the wiring compartment of the actuator.



CAUTION

Always close covers immediately after installation or service to prevent moisture or other foreign matter from entering the actuator.

CONDUIT ENTRIES

Conduits are provided for power and signal wiring. Temporary plugs are installed in the conduit entrances at the factory for shipping only and are not intended for permanent use. Prior to actuator operation, all conduit entrances must be properly sealed in accordance with National Standards or Regulatory Authorities.

GENERAL OPERATION INFORMATION

MODES OF OPERATION

There are three basic modes of operation:

- **Handwheel**—local mechanical control
- **Handswitch**—local electrical control
- **Automatic**—remote electrical control

Any or all of these modes can be used to test basic operation of your actuator during start-up.

HANDWHEEL

The Handwheel permits manual operation of the actuator without power. The Handwheel is coupled directly to the motor shaft at the rear of the motor housing and it rotates when the motor runs.

The Handwheel is particularly useful during initial installation or when power is not available. If power is available, the Handswitch must be moved to the STOP position before manually operating the Handwheel.

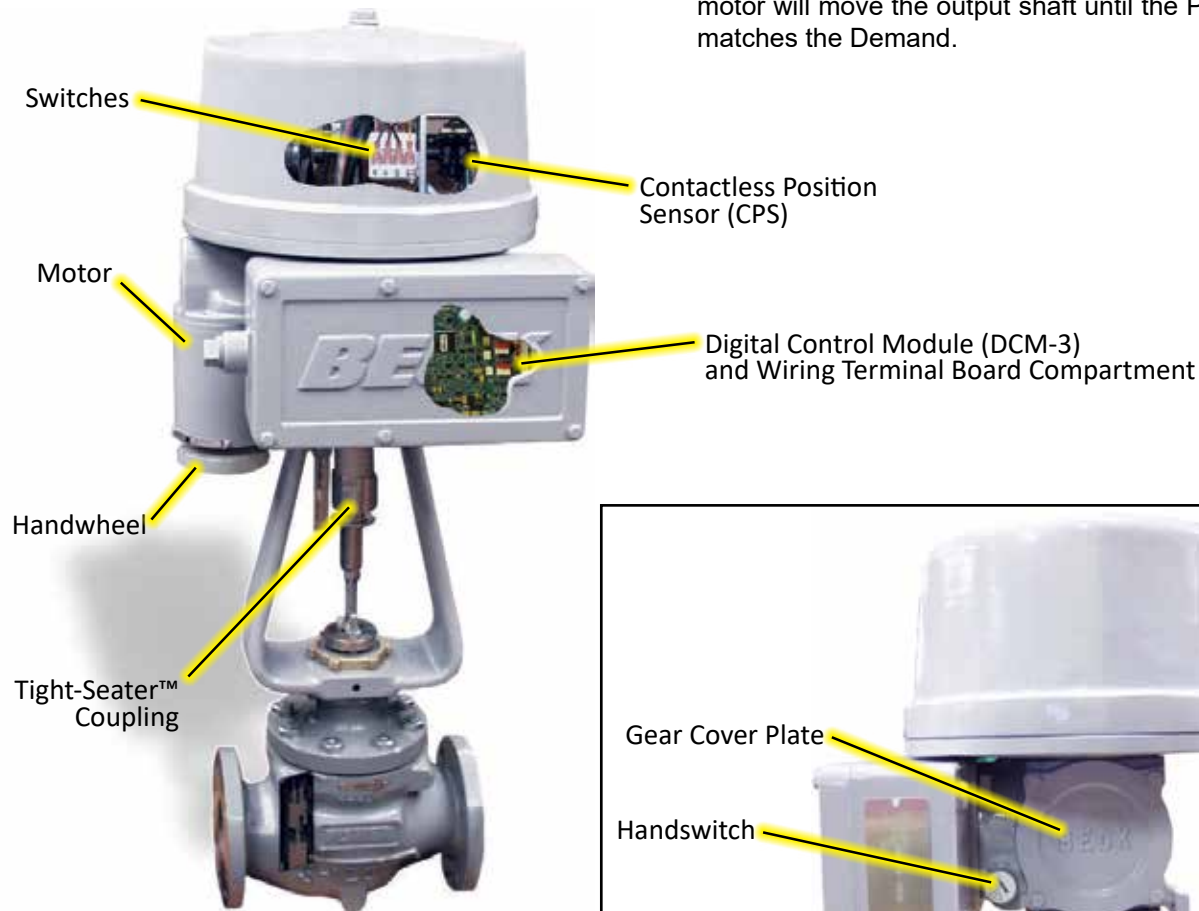

HANDSWITCH

A Handswitch allows local electric control at the actuator. In either of the STOP positions, the motor is blocked from running. In the RETRACT or EXTEND positions, the motor runs to move the output shaft in the corresponding direction. When moving the output shaft using the Handswitch, the motor will stop when the over-travel limit switches are reached.



The Demand signal can position the actuator only when the Handswitch is in the AUTO position.

AUTOMATIC MODE

When the Handswitch is placed in the AUTO position, the actuator is in automatic mode and responds to a Demand signal (also called the setpoint). The Digital Control Module (DCM-3) compares the Demand signal with the output shaft position. When the DCM-3 detects a difference between Demand and Position (called error), the motor will move the output shaft until the Position matches the Demand.

INSTALLATION Mechanical

UNITIZED VALVE/ACTUATOR ASSEMBLY INSTALLATION

Beck actuators can be furnished with valves mounted as unitized assemblies ready for pipeline installation. To install:

Inspect the valve and pipe flanges to ensure they are clean. Be certain that other pipelines in the area are free from pipe scale or welding slag that could damage the gasket surfaces.

Carefully lift the assembly and position the valve in the pipeline. Install and tighten the flange bolts according to the valve and/or gasket manufacturer's instructions.

NOTE: The valve may have undergone temperature variations in shipment. This could result in seepage past the stem seals. Refer to the valve manufacturer's maintenance instructions for packing adjustments, if required.

VALVE ACTUATOR INSTALLATION

Whenever an actuator is being mounted on a valve, refer to the valve manufacturer's maintenance manual for specific valve-related instructions. Consult the Beck Valve Mounting Specification sheet shipped with the actuator for specific instructions on assembly of the Beck actuator and mounting hardware to the valve. It is good practice to remove the valve from service if possible.



CAUTION

Working with valves installed in a pipeline can be dangerous. Take appropriate precautions when mounting to installed valves.

Mounting The Actuator On A Valve

See figure at right to identify mounting parts. Follow the steps to install the actuator onto the valve.

1. Prepare the valve. It may be necessary to remove parts that are no longer used or to replace or adjust packing. Refer to the valve maintenance manual for specific instructions. Consult the Beck Valve Mounting Specification sheet that was shipped with the actuator for any instructions regarding modifications to the valve stem that may be necessary.
2. Push the valve stem 9 into the valve body to the fully seated or stem down position.
3. Move the G-14 output shaft up into the actuator body until the upper mechanical stop 3 is tight against the lower bearing plate 1.
4. Remove the four lower bearing plate bolts 2 that hold the bottom plate to the actuator body (1/2" bolt heads). Pressure from the mechanical stop will hold the plate in place when the bolts are removed. Bolt the yoke 7 to the lower bearing plate using the longer bolts supplied with the yoke. Torque bolts to 10 lb-ft (13.5 N•m).

5. Place the jam nuts 5 and travel index 4 over the valve stem 9 before mounting the actuator on the valve.
6. Remove the boss nut 6 from the valve and place the actuator and yoke over the stem and onto the boss 10. Secure the yoke with the boss nut, hand-tight.
7. Using the actuator Handwheel, lower the actuator output shaft to contact the valve stem. Thread the valve stem into the end of the actuator output shaft. HINT: Rotate the whole yoke/actuator assembly to get the valve stem started into the actuator output shaft. Continue lowering the actuator output shaft and threading the valve stem until the actuator output shaft is fully down on the mechanical stop.
8. Tighten the boss nut to secure the yoke and tighten the yoke set screw 8.
9. Follow the valve seating adjustment procedure on page 11 to complete the mounting.

Removing the Actuator from a Valve

1. Move the Group 14 output shaft up into the actuator body until the mechanical stop 3 is tight against the lower bearing plate 1.
2. Turn off all electrical power and disconnect all electrical wiring from the actuator.
3. Loosen the valve stem jam nuts 5. Loosen the boss nut 6 on the yoke and leave it finger tight. Loosen the yoke set screw 8.
4. Unthread the valve stem from the actuator output shaft by turning the whole yoke/ actuator assembly.

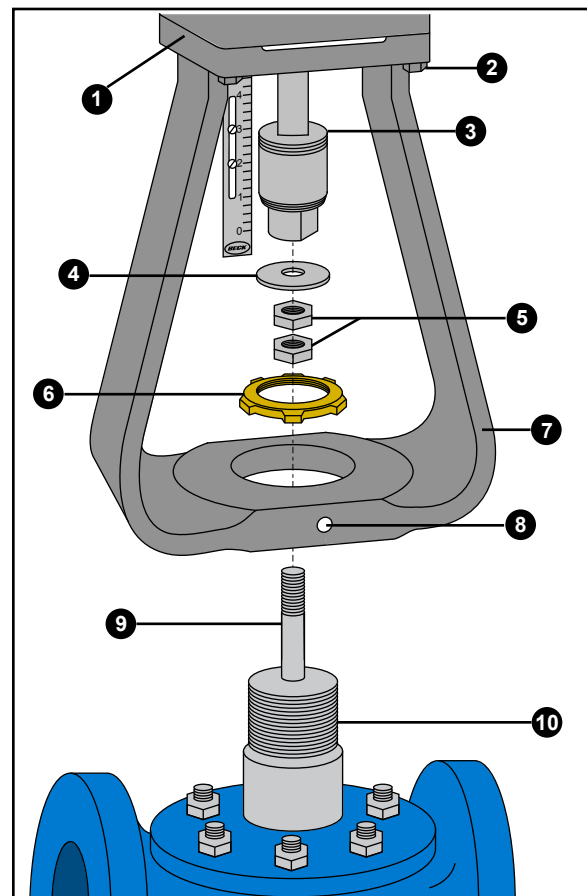

INSTALLATION *Electrical*

POWER QUALITY

Power quality disturbances such as power outages, transient voltages, harmonic distortions, and electrical noise will adversely affect your actuator performance. Protecting your actuator from these conditions can reduce downtime and promote longer life for the equipment. Following the industry accepted standards below will help protect your actuator.

- ✦ Select wiring materials according to the correct ampacity ratings dictated by national and local regulations.
- ✦ Shielded, twisted pair cables can be used for signal connections to avoid being affected by electrical noise. These signal wires, based on Noise Susceptibility Level (NSL) per IEEE-518, fall into the level 1 classification. A braided shield will be more effective than a wrapped foil shield. Signal wire shields should be connected to the actuator casting grounding screw. If grounding at the signal source is required, then the shield should not be grounded at the actuator.
- ✦ Raceways such as conduits and trays must be grounded at both ends to properly meet immunity requirements.
- ✦ An AC power ground connection should be made between the power source and the Beck actuator. Grounding connections including wire and metal conduit are permitted, but the actuator-grounding conductor may not be connected to a structured metal frame of a building.
- ✦ Surge suppression equipment that meets Underwriters Laboratory (UL) Standard 1449 may be used to protect against transient voltage conditions.
- ✦ Power Conditioners may be used to regulate the supply voltage and maintain a constant voltage level. They are helpful in protection against voltage sags and swells, as well as some measure of electrical noise protection.
- ✦ Harmonic filters may be used to minimize the effects of supply voltage waveform distortions and are used in applications that incur a large amount of high-frequency electronic noise.



CAUTION

Always close covers immediately after installation or service to prevent moisture or other foreign matter from entering the actuator.

ELECTRICAL INSTALLATION

Two conduit connections are provided in every Beck Group 14 actuator for supplying power and signal wiring to the unit. Conduits should be routed from below the actuator so that condensation and other contaminants flow away from the conduit. All conduit entrances must be properly sealed in accordance with National Standards or Regulatory Authorities.

To maintain signal integrity and meet most electrical codes, power and signal wires must be routed to the actuator separately. The signal wiring should be either shielded cables or be installed in conductive conduit and/or cable trays.

A large, clearly labeled terminal block on the side of the actuator is enclosed in a gasketed metal enclosure. Terminals will accommodate up to 12 AWG (3.31 mm²) wiring (see figure on page 10).



CAUTION

Always close covers immediately after installation or service to prevent moisture or other foreign matter from entering the actuator.

Refer to the wiring diagram furnished with your Beck actuator for proper AC power and signal connections. It is advisable to provide normal short circuit protection on the AC power line. A copy of the wiring diagram is shipped with each actuator and is fastened to the inside of the terminal block cover. If there is no wiring diagram available, you may obtain a copy from Beck by providing the serial number of your actuator.

Your Beck actuator has been supplied to match the signal source in your control loop. If it does not match, the input signal range is convertible by adding or removing a 250 ohm resistor—contact the factory for details.

For maximum safety, the Beck actuator body should be grounded. Normally, the electrical conduit provides adequate ground protection. If not, a separate ground conductor should be connected to the actuator body.

TERMINAL SCREW TORQUES

Each terminal screw should be torqued to the proper specification upon landing the wire.

Models	Terminals	Torque	
		(lb-in)	(N•m)
All Models	A-V	16	1.8
	AA-EE	12	1.4

INSTALLATION Wiring

Each Beck actuator is custom built to match the control requirements of your system specified at the time of order. Typical wiring connections are described below. Each actuator has a specific wiring diagram attached to the inside of the wiring terminal cover.

An actuator can be ordered with up to four optional auxiliary switches. Wiring connections for these are described on page 19.



Typical Wiring Connections

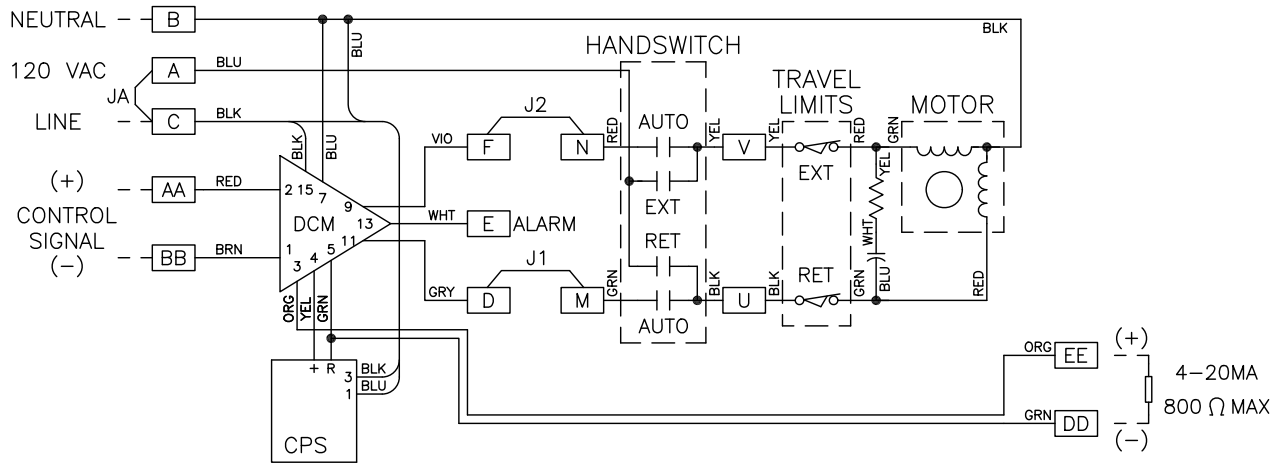

START-UP

START-UP CHECKLIST

The following list provides some basic checks that should be performed before placing your actuator into operation.

- Inspect the location and the mounting bolts. Be sure the actuator is securely fastened to the valve.
- On the first start-up, place the Handswitch in a STOP position to ensure that the output shaft will not move and possibly cause personal injury.
- Confirm the actuator is receiving the appropriate operating voltage as shown on the nameplate.
- Check the DCM-3 Power LED. It should be pulsing (Dim/Bright) to indicate the board is active.
- Using the Handswitch, confirm the actuator moves fully to both the RETRACT and EXTEND ends of travel.
- Confirm the actuator has a 4–20 mA Demand signal attached to terminals AA (+) and BB (–).
- Place the Handswitch in AUTO and vary your Demand signal from 0% to 100%.
- Check for the Status alarm LED on the DCM-3. If it is lit, refer to the Troubleshooting section of this manual.
- Verify that the output shaft is moving to the desired 0% position with a 0% Demand signal and moving to the 100% position with a 100% Demand signal. If they are reversed, see the Configuration/Calibration section of this manual for instructions on how to change the direction of output shaft rotation.

Valve Seating Adjustment

The actuator has a Tight-Seater™ attached to its output shaft. The Tight-Seater™ allows tight seating of the valve plug. It is a pre-loaded coupling that allows the valve plug to seat before the actuator reaches its lower limit. The additional amount of travel compresses the thrust discs inside the Tight-Seater™, causing a controlled amount of thrust to hold the valve plug on its seat when the actuator stem reaches its lower limit. The Tight-Seater™ is factory-set to produce a thrust matched to the valve and should never be disassembled. Control of the amount of valve stem threaded into the Tight-Seater™ may be used to adjust the valve seating.

If readjustment of valve seating is necessary, proceed as follows:

1. With the Handswitch, run the actuator to a position above the 0% or lower limit position.
2. Loosen the lock nut on the valve stem and thread the valve stem into the Tight-Seater™.
3. Run the actuator to the 0% position, using a Demand signal source.
4. Thread the valve stem out of the Tight-Seater™ until the plug seats in the valve.
5. Raise the actuator shaft using the Handswitch until the plug is clear of the seat and there is sufficient clearance to make the following adjustment.
6. Thread the valve stem out of the Tight-Seater™ a fraction of a turn according to the valve stem thread as listed (1/32" travel):

Thread	Turn
3/8-24	3/4
7/16-18	5/8
1/2-20	5/8
3/4-16	1/2

7. Tighten the lock nut and index disc on the valve stem.
8. Run the actuator to its lower limit using the Handswitch. The valve stem should stop before the actuator shaft stops.
9. Reposition the travel index.



CAUTION

If the valve stem is threaded directly into the actuator shaft without a Tight-Seater™, the valve stem should be at least 1/4 turn from the seated plug position when the actuator shaft reaches the lower limit. This will prevent damage to the valve stem or seat. Do not attempt to obtain tight shut-off without a Tight-Seater™ as serious valve damage may result.

COMPONENTS Mechanical

HOUSING

All models of the Beck Group 14 actuator have individual, cast aluminum compartments for the main components: The control motor, wiring terminal board, actuator train, Digital Control Module, and feedback section. Gasketed covers and sealed shafts make this product ideally suited for outdoor and high-humidity environments.

CONTROL MOTOR

The Beck control motor is a synchronous inductor motor that operates at a constant speed of 72 RPM in synchronism with the line frequency.

Motors are able to reach full speed within 25 milliseconds and stop within 20 milliseconds; actual starting and stopping times vary with load.

Beck motors have double grease-sealed bearings and require no maintenance for the life of the motor.

DRIVE TRAIN

The Group 14 drive train consists of a control motor, SLM, Handwheel, reduction gears, main gear, and power screw output shaft. The ductile iron main gear and the bronze nut and stainless steel power screw output shaft are common to units of a particular range of thrust and timing. The steel reduction gears are part of the field changeable gear housing assembly. Different combinations of output gear, housing assemblies, and actuator motors determine the actuator's output thrust, timing and stroke adjustment.

The output shaft travel is limited by mechanical stops. The mechanical stop for the fully extended or lower limit of the output shaft travel is not adjustable. The position of the retracted or upward travel mechanical stop is determined by the number of washers on the output shaft between the Tight-Seater™ and the lower bearing plate. This is factory-set for the amount of travel specified at the time of the order and is generally not changed in the field.

The amount of output shaft travel is determined by the setting of the Calibar. Moving the Calibar block away from the output shaft increases the radius where the ball bearing contacts the sector gear lever. The longer the radius the longer the vertical stroke of the output shaft for the same amount of rotation of the control end shaft. Therefore, the Calibar changes the output shaft travel but makes it unnecessary to change the switch cams or CPS-5. Field Calibar adjustment is generally used to shorten the travel. Consult the factory if a longer stroke is required.

SELF-LOCKING MECHANISM (SLM)

An integral part of every Group 14 control motor is the self-locking mechanism. This mechanical device couples the motor to the gear train and transmits full motor torque when rotated in either direction. When the motor is de-energized, it instantaneously locks and holds the output shaft in position.

TIGHT-SEATER™

The Beck Tight-Seater™ assembly is a pre-loaded coupling that is installed between the actuator output shaft and the valve stem. It produces a controlled positive pressure against the valve seat, independent of actuator thrust.

The Tight-Seater™ consists of four parts: A housing attached to the output shaft, linear thrust discs contained in the housing, a flanged coupling attached to the valve stem, and a threaded ring to contain the flanged coupling in the housing and to allow adjustment of the pre-load on linear thrust discs.

The factory pre-load, by a threaded ring, ensures that no relative motion occurs between the flanged coupling and housing during normal valve operation until the pre-load thrust is exceeded in the seated plug position of the valve.

When the seated plug position of the valve is reached, the flanged coupling on the valve stem is stationary, and the output shaft exceeds the pre-load pressure of the Tight-Seater™. When the pre-loaded pressure is exceeded, the housing will compress the linear thrust discs, maintaining a controlled pressure on the valve seat, with the shaft stationary.

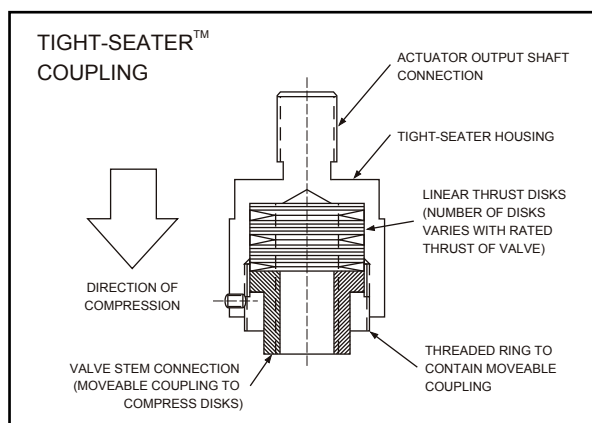

Tight-Seater™

HANDWHEEL

Every Beck Group 14 linear actuator is furnished with a Handwheel for operation of the valve without electrical power. Its solid construction design includes no spokes or projections, and turns at a safe, slow speed. The Handwheel is located at the bottom of the control motor housing. The Handwheel is coupled directly to the motor shaft and rotates when the motor runs. Manual operation of the Handwheel (with electric Handswitch in STOP position) turns the motor and the rest of the actuator train without incorporating a clutch.

HANDSWITCH

A local electric Handswitch is provided on Beck actuators to permit operation at the valve, independent of the controller. As a safety feature, the Handswitch is designed so that the controller can operate the actuator only when it is in the AUTO position. The sequence of the Handswitch is: AUTO, STOP, RETRACT, STOP, EXTEND.

In the AUTO position, two contacts are closed and the DCM-3 contact completes the control circuit.

In the RETRACT or EXTEND positions, contacts are closed to operate the actuator independently of the controller.

In the STOP position, all contacts remain open.

SWITCHES

Two over-travel limit switches and two auxiliary switches are provided on Group 14 actuators. Two additional auxiliary switches are available as an option. Switch cams are clamped onto the control shaft, which rotates in relation to the output shaft. Cam position is field-adjustable. Switches are enclosed in high-impact thermoplastic. Switches are rated 6 A, 120 V ac (0.5 A, 125 V dc). All auxiliary switch connections are made on the terminal board.

COMPONENTS *Electronic*

CONTROL & CONTACTLESS POSITION SENSOR (CPS-5)

The actuator top cover houses the limit switch assemblies and the Contactless Position Sensor (CPS-5). The CPS-5 is the electro-mechanical device that provides the DCM-3 with a continuous feedback signal proportional to the position of the actuator's output shaft.

The control area includes a control shaft, which is geared directly to the output shaft of the actuator. Movement of the output shaft causes rotation of the control shaft, which in turn moves the limit switch cams and the CPS-5 ferrite rotor. A ferrite magnetic sensing element generates a voltage as the rotor turns. The voltage is translated into a position signal voltage used by the DCM-3 to control the actuator.

The typical position signal voltage of the CPS-5 ranges from 1.0 V dc at the Extend end of travel, to 5.0 V dc at the Retract end of travel. The DCM-3 can be calibrated to interpret CPS-5 position signals between 0.3 V dc and 5.3 V dc. Position signal voltages can be measured on the yellow (+) and green (R) position signal wires located on the CPS-5. The CPS-5 power is derived from the blue and black wires on the primary side of the transformer. 120 V ac can be measured across the transformer tabs (blue and black wires).

There are two SPDT over-travel limit switch assemblies (labeled "EXT" and "RET") and up to four auxiliary switch assemblies (labeled "S1" through "S4").

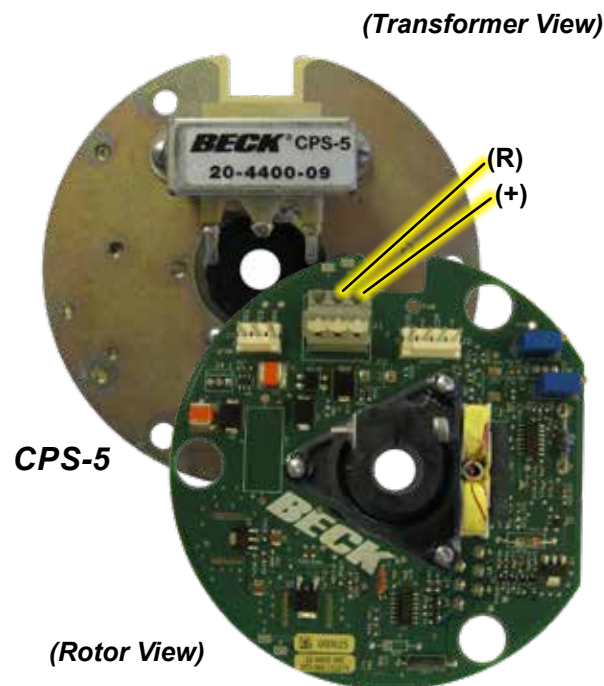

DIGITAL CONTROL MODULE (DCM-3)

The DCM-3 is a micro-processor based circuit board assembly that serves as the actuator's control center.

The main function of the DCM-3 is to position the actuator's output shaft. The DCM-3 compares the 4–20 mA Demand signal received at the actuator terminals AA(+) and BB (-) to the actuator position signal, generated from the Contactless Position Sensor (CPS-5). If a difference exists (called error) between the Demand and Position signals, the DCM-3 activates triacs that operate the motor. The motor drives the gear train and positions the output shaft until the difference is eliminated.

The DCM-3 layout is shown on page 18 and includes the fuse and test point locations. The typical position signal voltage from the CPS-5 (measured from TP1(-) and TP4(+)) ranges from 1.0 V dc at the Extend end of output shaft travel, to 5.0 V dc at the Retract end of output shaft travel. Test point voltage levels between TP2(+) and TP3(-) across the input resistor R11 should read between 1 V dc and 5 V dc proportional to the 4–20 mA Demand signal.



DCM-3

INTERFACES

The DCM-3 has three configuration interfaces: Pushbutton, HART, and Serial Port.

PUSHBUTTON

The DCM-3 board is equipped with pushbuttons that can be used to calibrate the Demand signal and configure 0% and 100% positions. It may also be used to configure the direction of output shaft rotation for increasing Demand. These configurations and calibrations do not require any external equipment to perform.

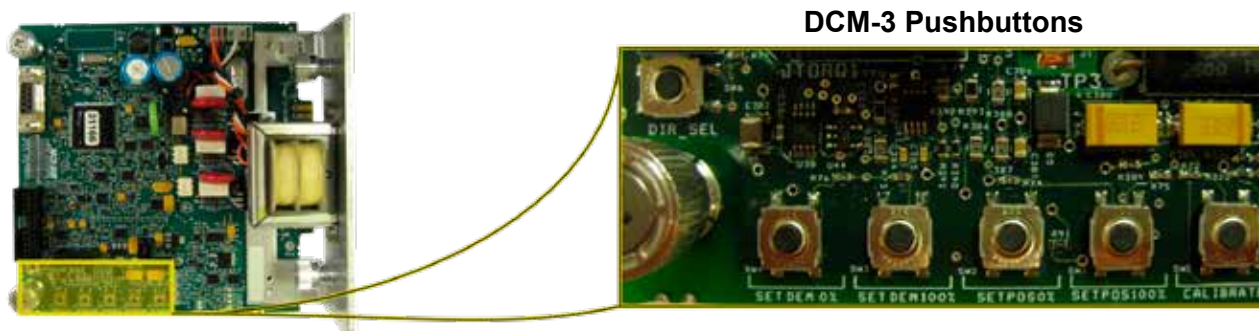

HART

The HART interface is accessible by connecting a HART capable communication device (such as a handheld communicator) to terminals AA (+) and BB (-) of the terminal block area. A HART-capable, analog output can be used for the Demand signal as well. All electronic calibration and configuration can be accomplished through the HART interface. NOTE: The appropriate HART device descriptions are required.

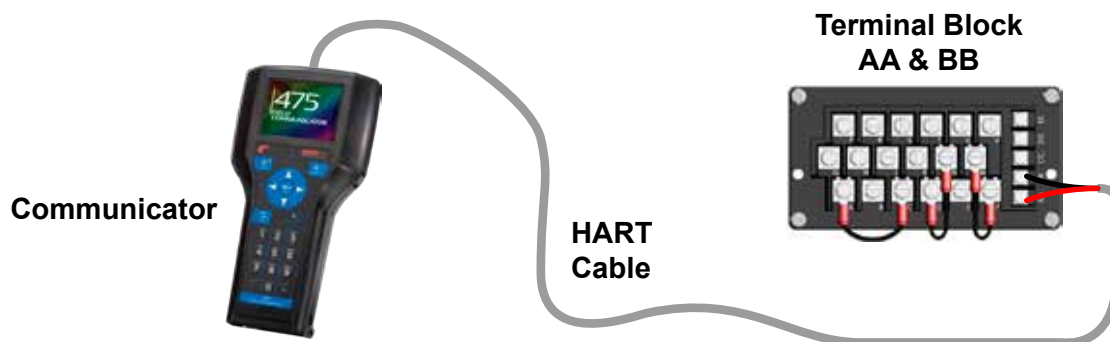

SERIAL PORT

The Serial port interface is accessible by connecting a computer to the DCM-3 using the DB9 connector. See the Serial Communications appendix for details on connecting via the Serial port. All electronic calibration and configuration can be accomplished through the Serial port interface.



COMPONENTS Electronic

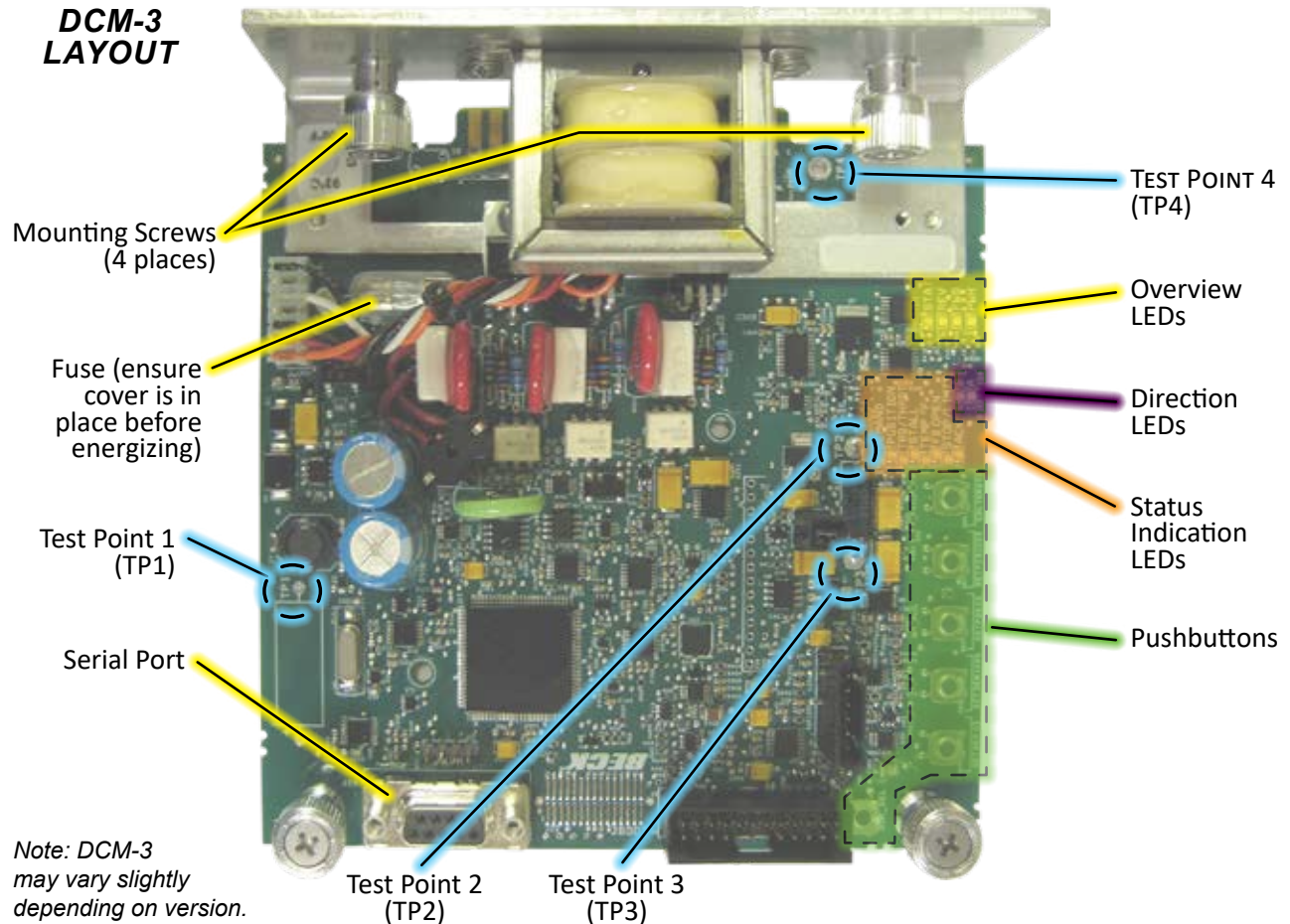

OVERVIEW LEDs

Located on the DCM-3 board (pictured above), these LEDs indicate the basic, real-time state of the actuator. A description of each LED follows.

STAT

This red LED illuminates during a system alarm. Explanation of the specific alarm is available through the Fieldbus or Serial interface. See the Troubleshooting section for additional information.

REV

This green LED illuminates when the actuator is receiving a Demand signal less than its position.

FWD

This green LED illuminates when the actuator is receiving a Demand signal greater than its position.

PWR

This green LED illuminates when power is applied to the actuator. This LED pulses from bright to dim indicating the DCM-3 is operational.

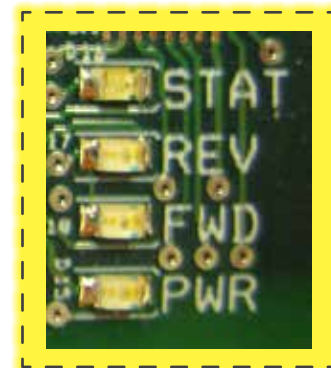

OVERVIEW LEDs

DIRECTION LEDs

These green LEDs indicate the direction of travel resulting from an increasing Demand signal.

DIRECTION LEDs

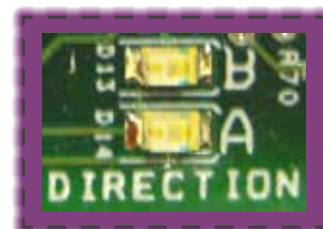

A = EXT B = RET

STATUS INDICATION LEDs

When the "STAT" LED is lit, the applicable red indication LED(s) will light to reveal the actuator condition(s). An alarm is also available at terminal E. When the condition is corrected, the status will automatically reset.

DEMAND

Loss of the Demand input signal.

POSITION

The Position signal to the DCM-3 is out of the calibrated range limits. The lower limit is -5% and the upper limit is 105% of the calibrated range. May also indicate a film potentiometer or internal wiring failure.

TRQ/THRST

This LED is inactive for Group 14 actuators.

STALL

The actuator is in a stall condition and stall protection has been activated.

TEMP °F.

Drive's internal temperature is outside of rating.

FB OPEN

External position Feedback signal is enabled, but not wired to an external load or the wiring has failed between the actuator and the monitoring device.

STOP/LIMIT

Handswitch is in "STOP" position or the actuator is at a limit and is not in balance.

ACK

Acknowledges when a calibration procedure has been completed.

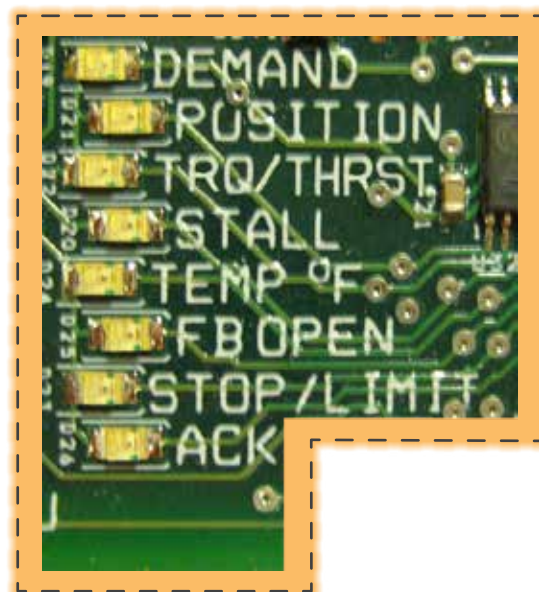

STATUS INDICATION LEDs

PUSHBUTTON CONTROLS

The five pushbuttons (pictured below) on the DCM-3 customer interface panel are used for calibration. When pressing a pushbutton, pressure should be maintained until the "ACK" LED is lit; this confirms receipt of the pushbutton command. See the Configuration/Calibration section of this manual for further explanation of calibration procedures.

CALIBRATE

This button must be pressed and held simultaneously with another pushbutton to perform a calibration.

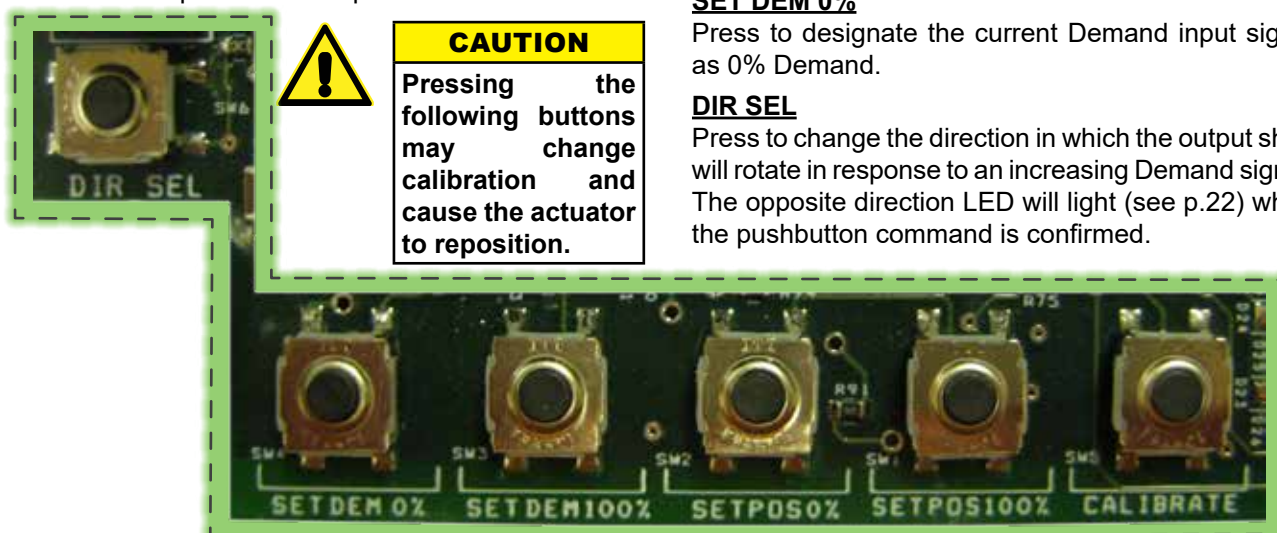

PUSHBUTTON CONTROLS

SET POS 100%

Press to designate the current position of the output shaft as the 100% position for actuator movement (this will correspond to a 100% Demand signal).

SET POS 0%

Press to designate the current position of the output shaft as the 0% position for actuator movement (this will correspond to a 0% Demand signal).

SET DEM 100%

Press to designate the current Demand input signal as 100% Demand.

SET DEM 0%

Press to designate the current Demand input signal as 0% Demand.

DIR SEL

Press to change the direction in which the output shaft will rotate in response to an increasing Demand signal. The opposite direction LED will light (see p.22) when the pushbutton command is confirmed.

CONFIGURATION/CALIBRATION

All Beck actuators are shipped completely calibrated to the customer's specifications that were written into the equipment order and are ready to be installed. If the need arises to change the actuator calibration, first confirm that the actuator is installed as specified and operating properly before proceeding with the change.

Position reference and Demand calibration are performed using the DCM-3 customer interface panel, but may also be configured using the HART or Serial interface. Calibration of over-travel limit and auxiliary switches must be performed using the procedure beginning on page 19.

CALIBRATION PRIORITY

Standard Group 14 actuators are equipped with built in mechanical stops. All output shaft movement must occur within these stops.

The over-travel limit switches are used to limit the electrical control range of the actuator. These switches are cam operated, and are set slightly wider apart than the actuator's intended full range of electronic operation. With this range, the limit switch cams are each set inside the mechanical stops, and are positioned to provide an electrical over-travel protection without opening in the normal operating range. If the actuator stroke is changed by adjusting the caliber (see page 21), the limit switches are simultaneously adjusted.

The auxiliary limit switches are also cam operated, but have no affect on actuator and DCM operation. Therefore, they can be adjusted at any time without affecting performance or calibration.

SWITCH CALIBRATION

NOTE: Your Beck actuator was shipped from the factory ready for installation; no electrical adjustments are required before placing it in operation. Each actuator is set up and calibrated to the specifications that were written into the equipment order.

Under normal operating conditions there is no need to recalibrate the actuator. However, if the application requirements change or are different than specified on the equipment order, the actuator should be recalibrated according to the following procedures.

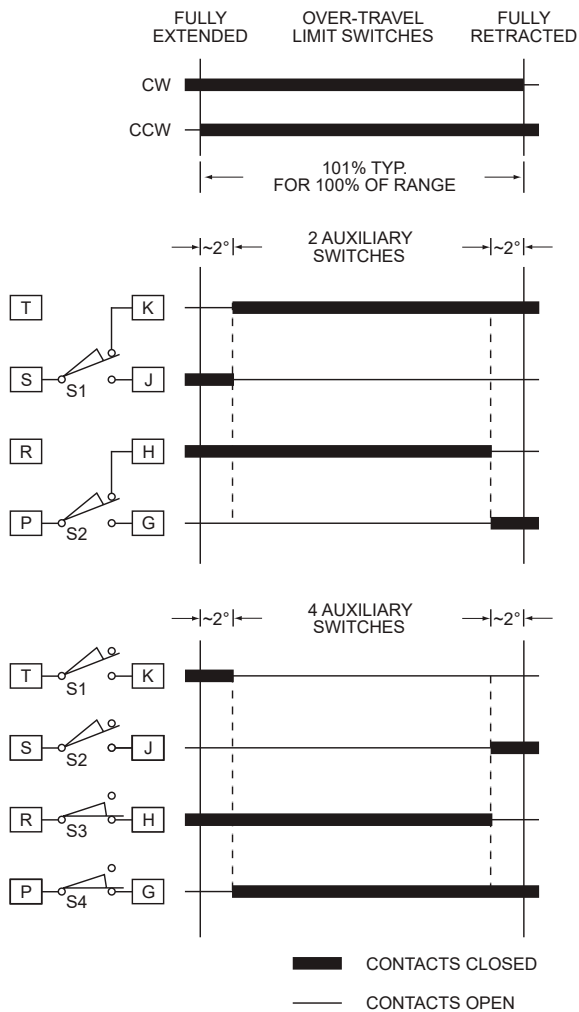

Standard Over-travel Limit and Auxiliary Switch Settings

Switch Adjustments

All actuators are shipped with over-travel limit switches factory-set for 101% of travel unless otherwise specified at time of order. Limit switches must be set inside the range of the built-in mechanical stops to prevent stalling of the motor. Limit switches can be reset to limit travel of the output shaft. Optional auxiliary switches are set as shown in the illustration at left unless otherwise specified at time of order.

Switches are operated by cams which are clamped onto the control shaft. Setting a switch involves loosening the cam, moving the actuator's output shaft to the desired position, and positioning the cam so that it operates the switch at that point. In the following procedure, the use of a continuity meter is recommended to determine when the switch opens or closes. If such a meter is not available, it is possible to hear the switch click as the contacts open and close.



CAUTION

Do not attach the meter or attempt to move the switch cams until the actuator is disconnected from the line voltage and auxiliary switches are disconnected from external power sources.

Setting Over-travel Limit Switches RET and EXT

This procedure should be used if the factory over-travel switch settings must be changed in the field. It is advisable to operate the actuator fully in each direction—using the electric Handswitch—to check switch settings before attempting to change them. Use the following instructions if they require adjustment:

Continued



Loosen Cam

CONFIGURATION/CALIBRATION

SETTING OVER-TRAVEL SWITCHES, CONT'D.

1. Remove the top cover (15/16" bolt head). The O-ring seal will remain in the rim of the top cover when removed. Open the terminal block cover (1/2" bolt head).
2. Use the electric Handswitch to move the control shaft so that the EXT switch cam is accessible. Using a 7/64" hex wrench, loosen the screw so that the cam is just snug to the shaft. See figure on page 19.
3. Use the Handwheel to position the control shaft so that the lever of the sector-lever gear assembly is parallel with the upper bearing plate. See figure below for location of lever and bearing plate.



Lever and Bearing Plate

4. Disconnect power from the actuator.
5. Connect the continuity meter across terminals B and V. Rotate the cam until the meter shows no continuity (a switch contact opens; switch clicks).
6. Tighten the cam locking screw to 5 lb-in (0.56 N•m) torque.
7. Disconnect the meter and reconnect switch wires and actuator power.
8. Using the Handswitch, drive the output shaft to the fully retracted position. Note the direction of rotation of the lobe of the cam. The correct cam lobe motion is away from the switch lever with the switch lever on the lower part of the cam. If this is not correct, return to step 2 and reset the cam to the proper orientation.
9. Drive the output shaft again to the fully extended travel limit. If the correct stopping point is reached (lever parallel with the upper bearing plate), the switch is properly set.
10. Manually position the control shaft position indicator dial to zero.
11. With the Handswitch, move the control shaft until the position indicator dial reaches the 150° position.
12. Repeat the instructions for setting the RET travel limit except that the direction of motion is opposite to that used for the EXT switch setting. Connect the continuity meter across terminals B and U.

13. Close the covers and tighten the terminal cover bolt to 10 lb-ft (13.5 N•m). Tighten the top cover bolt just enough to compress the O-ring seal.

Setting Auxiliary Switches

Standard switch settings for actuators with 2 or 4 auxiliary switches are shown on the diagram on page 19. The operating point of all auxiliary switches is defined as a percentage of output shaft travel. 100% is defined as the retracted limit of shaft travel. The heavy line indicates a closed circuit. Follow these instructions to change the operating point of auxiliary switches:

NOTE: In the following procedure, it is assumed that switch settings are to be adjusted so that contacts are open when the desired position is achieved. If they are to be adjusted to close, it may be necessary to reverse the operating mode of the switch by reversing the leads on the switch itself. Be sure to disconnect power from the switch terminals first.

1. Remove the top cover (15/16" bolt head). The O-ring seal will remain in the rim of the cover when removed. Open the terminal block cover (1/2" bolt heads).
2. Use the electric Handswitch to actuator the shaft so that the switch cam is accessible. Using a 7/64" hex wrench, loosen the screw so that the cam is just snug on the shaft.
3. Move the output shaft to the desired position.
4. Disconnect power from the actuator.
5. Connect the continuity meter across the appropriate terminals. See the actuator wiring diagram or the diagram on page 10. Rotate the cam until the meter shows no continuity (switch contacts open, switch clicks).
6. Tighten the cam locking screw to 5 lb-in (0.56 N•m) torque.
7. Disconnect the meter and reconnect power.
8. Move the actuator's output shaft in the desired direction so the cam lobe moves away from the switch lever. If not correct, return to step 2 and reset the cam to proper orientation.
9. Reconnect the meter.
10. Move the output shaft again toward the desired switch position. If the contacts open, the switch is properly set.
11. Close covers and tighten the terminal cover bolts to 10 lb-ft (13.5 N•m) torque. Tighten the top cover just enough to compress the O-ring seal.

STROKE CHANGE—CALIBAR

Adjustment of the total actuator stroke within the factory-set travel range is easily accomplished by the use of the Beck Calibar (see figure, this page). The switches and feedback device are simultaneously adjusted to maintain full input span when the Calibar setting is changed. For stroke lengths longer than factory-set travel limits, consult the factory. Adjust actuator stroke as follows:

1. Remove the top cover. The protective O-ring seal will remain in the rim of the top cover when removed.
2. The Calibar index is graduated directly in inches, which corresponds to the actuator travel span.
3. Loosen the two locking screws on the Calibar block with an 1/8" hex wrench (See figure, this page).
4. Slide the Calibar block, aligning the notch with the desired travel span on the Calibar index. Tighten the set screws.

NOTE: If increasing the travel span within the factory-set travel range, a portion of the upper mechanical stop will have to be removed and the Calibar index plate notch should be enlarged to accommodate the adjustment of the Calibar block to the new stroke.

5. Use the Handswitch to operate the actuator and check the stroke on the travel index of the valve yoke.
6. Replace the top cover after making adjustments. Tighten the top cover just enough to compress the O-ring seal.

NOTE: The limit switches and feedback device are adjusted automatically when the Calibar setting is changed. Do not adjust the limit switch cams to change the actuator stroke. It is desirable, however, to calibrate the DCM-3 position reference to match the Calibar setting. See page 24.

STROKE AND SPAN ADJUSTMENTS

The Calibar adjustment is designed to allow field changes of the total actuator stroke with the same maximum input signal applied (e.g., a change from 1 1/2" (38 mm) stroke with 20 mA input signal to a 1" (25.4 mm) stroke with 20 mA input signal).

The span adjustment on the DCM-3 board is used to maintain the actuator stroke when a change in input signal (or span) is required (e.g., a change from 3/4" stroke with a 20 mA maximum input signal applied to 3/4" stroke with an 18 mA maximum input signal applied).



Calibar Block

CONFIGURATION/CALIBRATION

DIRECTION OF OUTPUT SHAFT TRAVEL (RET VERSUS EXT)

Travel direction of the actuator is determined when looking at the output shaft. Direction of travel is defined as the direction of output shaft movement produced by an increasing demand signal. Unless otherwise specified at the time of order, the output shaft is factory-set to retract in response to an increasing signal.

Changing the direction of output shaft travel is easily accomplished using any of the following methods.

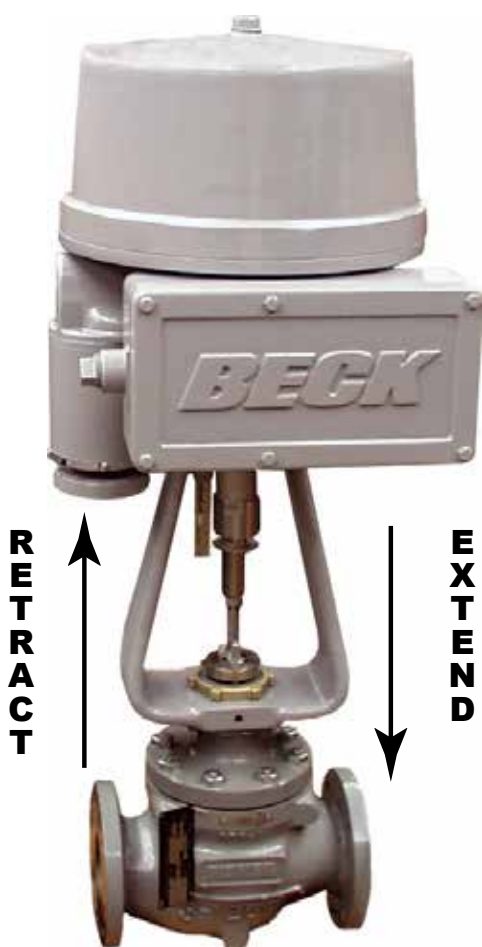

Pushbutton method

1. Remove the DCM-3 cover (1/2" bolt heads).
2. Press and hold the "CALIBRATE" pushbutton, then press the "DIR SEL" pushbutton until the (opposite) "DIRECTION" LED is lit.

—OR—

2. Position the actuator at the current 0% position.
3. Press and hold the "CALIBRATE" pushbutton, then press the "SET POS 100%" pushbutton until the "ACKNOWLEDGE" LED is lit.*

—OR—

2. Position the actuator at the current 100% position.
3. Press and hold the "CALIBRATE" pushbutton, then press the "SET POS 0%" pushbutton until the "ACKNOWLEDGE" LED is lit.*
4. Ensure the actuator operates as desired.
5. Replace the DCM-3 cover and tighten the cover bolts to 10 lb-ft (14 N•m) torque. Reset travel index.

* If the "ACKNOWLEDGE" LED does not light, but the "POSITION" LED does light, the change was not accepted by the DCM-3.

NOTE: When any of the above procedures is performed, both the 0% and 100% positions are automatically set.

HART method

Command: Actuator Dir

DD Menu Location: MENU 4B

Functions>Configuration>General Setup

Selections:

RET Incr - select if the desired output shaft rotation is retract on increasing Demand signal.

EXT Incr - select if the desired output shaft rotation is extend on increasing Demand signal.

Serial command method

Command: drvdir *n*

Arguments: *n*

0: Retract - select if the desired output shaft movement is to retract on an increasing Demand signal.

1: Extend - select if the desired output shaft movement is to extend on an increasing Demand signal.

STEP SIZE

Step size represents the minimum amount that the Demand signal must change to initiate a change in actuator position.

When the actuator is in AUTO mode, the DCM-3 runs the motor until the output shaft position matches the percentage of Demand signal. When they match, power is removed from the motor. The Demand signal must change by the step size before power is returned to the motor.

The step size is factory set to 0.15% of full travel span, unless otherwise specified at the time of order. The step size is adjustable from 0.1% to 2.5% of the travel span. Adjustment is typically not required.

It may be advantageous in certain applications, where noise or other problems exist, to increase the step size slightly to prevent excessive modulation.

The step size can be changed using the following methods.

NOTE: Changing this parameter online could cause the actuator to reposition.

HART method

Command: StepSize

DD Menu Location: MENU 4B

Functions>Configuration>General Setup>

Enter the desired step size between "0.10%" and "2.50%".

Serial command method

Command: stepsize #.##%

Arguments: #.##% Desired step size of one incremental movement of output shaft travel (as a percentage of full travel). Acceptable range is between "0.10" and "2.50". If the "%" is not included in the argument, the unit of measurement will default to inches.

RESTORE FACTORY SETTINGS

All DCM-3's are shipped from the factory configured per the customer instructions at the time of order. A complete copy of the factory configuration is stored on the DCM-3. You can revert to the factory settings at any time using one of the following methods.

NOTE: When the factory settings are restored, the Operation Mode (HART DD menu location 3E or Serial command "opmode") will not be changed for safety reasons. The operation mode should be set to "Follow" for normal automatic operation.

HART method

Command: Restore to Factory

Running this function will restore all configurable parameters to the original factory settings.

DD Menu Location: MENU 3C

Functions> Configuration

Serial command method

Command: restoremodes *n*

Arguments: *n*

1: Used as a safety measure, the number one must be entered as an argument to prevent someone from running the restoremodes command errantly.

CONFIGURATION/CALIBRATION

POSITION CALIBRATION

In order to correctly position the actuator output shaft in response to the Demand input signal, the DCM-3 receives a position signal from the actuator's position sensor and compares this actual position to the Demand input. This process requires that the DCM-3 interprets the position signal appropriately for the full range of desired travel. This procedure will calibrate the DCM-3 to accept the position signal and interpret the appropriate 0–100% range. Note that all actuators come factory calibrated and there is no need to recalibrate unless changes in operation are desired.

NOTE: Prior to adjusting the travel range electronically (using the DCM-3), it is recommended that the over-travel protection switches be reset just outside the intended travel range (see page 19). If, however, the calibar setting has been changed (see page 21), the switch settings will have already been adjusted automatically.

Calibrate the 0% and 100% positions:

Pushbutton method

1. Move the output shaft to the desired 0% position.
2. Press and hold the "CALIBRATE" pushbutton then press the "SET POS 0%" pushbutton until the "ACKNOWLEDGE" LED is lit.
3. Move the output shaft to the desired 100% position.
4. Press and hold the "CALIBRATE" pushbutton then press the "SET POS 100%" pushbutton until the "ACKNOWLEDGE" LED is lit.
5. Adjust over-travel limit switches as necessary to accommodate the new positions.

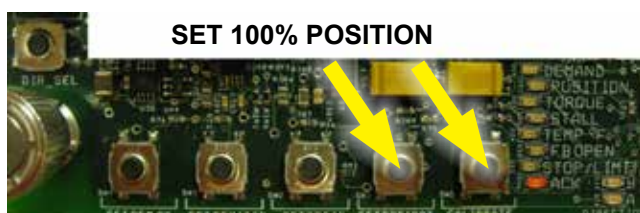
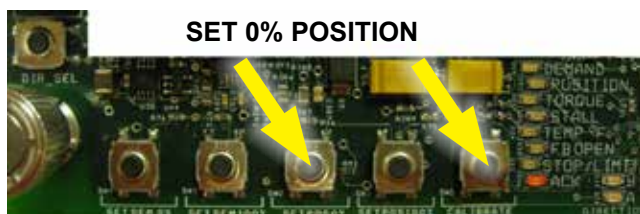

HART method

Command: Set Pos 0%

Select when the output shaft is at the desired 0% position.

Command: Set Pos 100%

Select when the output shaft is at the desired 100% position.

DD Menu Location: MENU 4C

Functions>Configuration>PositionSensrSetup>

Change Travel Inches:

HART method

Command: Travel

Enter the desired full stroke travel in inches.

HART DD Menu Location: MENU 4B

Functions>Configuration>General Setup>

Serial command method

Command: travel #.##

Arguments: #.## The desired full-stroke travel in inches.

DEMAND CALIBRATION

DCM-3 boards are designed to accept a 4–20 mA (or 1–5 V dc) analog Demand signal. The input comes calibrated from the factory for the full range unless otherwise specified by the customer. It is not necessary to calibrate the Demand input when the actuator is installed; however, if the Demand needs to be calibrated to accommodate unusual operating conditions, two guidelines must be followed: First, the value for 0% must be greater than 0.5 mA and the value for 100% must be less than 21 mA. Second, the difference between 0% and 100% (minimum span) must be at least 4 mA. Use any of the following methods to calibrate Demand. Actuators may also be configured for split-range operation—contact the factory for details.

Calibrate the 0% and 100% Demand signal:

Pushbutton method

1. Ensure the Handswitch is in the “STOP” position. This will prevent the actuator from repositioning during this procedure.
2. Apply the desired 0% Demand input signal to the actuator (e.g., 4 mA for 4–20 mA signal).
3. Press and hold the “CALIBRATE” pushbutton on the DCM-3, then press the “SET DEM 0%” pushbutton until the “ACKNOWLEDGE” LED is lit.*
4. Apply the desired 100% Demand input signal to the actuator (e.g., 20 mA for 4–20 mA signal).
5. Press and hold the “CALIBRATE” pushbutton on the DCM-3, then press the “SET DEM 100%” pushbutton until the “ACKNOWLEDGE” LED is lit.*
6. Turn the Handswitch to the “AUTO” position. NOTE: The actuator may reposition.
7. Run the actuator through its full operational range to ensure proper response to the Demand input signal.
8. Replace the compartment covers and tighten the cover bolts to 10 lb-ft (14 N•m) torque.

*If the “ACKNOWLEDGE” LED does not light, but the “Demand” LED does light, the calibration is out of acceptable range and was not accepted by the DCM-3. This is typically caused by trying to set 0% and 100% values too close together (i.e., less than 4 mA difference).

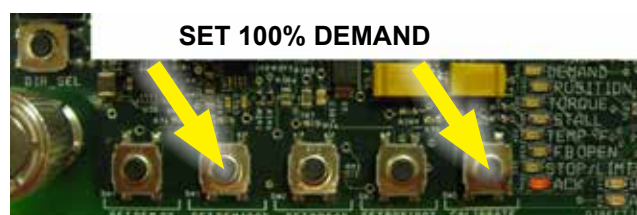

HART method

Command: DemRngLwr
Enter the desired 0% Demand signal ("4.00" to "16.00" mA).

Command: DemRngUp
Enter the desired 100% Demand signal ("8.00" to "20.00" mA).

DD Menu Location: MENU 4D
Functions>Configuration>Demand Setup>

Serial command method

Command: dem0pctma #.##

Arguments: #.## Desired 0% Demand signal ("4.00" to "16.00" mA).

Command: dem100pctma #.##

Arguments: #.## Desired 100% Demand signal ("8.00" to "20.00" mA).

CONFIGURATION/CALIBRATION

LOSS OF DEMAND SIGNAL (LOS)

The DCM-3 is capable of determining if the Demand input signal to the actuator is outside of an acceptable range. The DCM-3 uses a configurable loss of signal (LOS) threshold to determine if the Demand signal falls below a minimum value. Unless otherwise specified in the original order, the factory set threshold is 3.2 mA. When the DCM-3 senses an LOS condition, an alarm condition will result, illuminating the "Demand" status indication LED. The actuator then responds according to the LOS setting. The DCM-3 can be configured for one of two LOS actions:

1. **Stay in Place**—the actuator output shaft stays in place until the Demand signal returns to the acceptable range. This is the factory default.
2. **Go-to-Position**—the actuator output shaft will move to a preset position, designated in percentage of travel. For example, if the LOS action is set for 50%, the actuator output shaft will drive to the 12 mA position (based on a 4-20 mA span).

The LOS parameters can be configured using HART or Serial commands.



CAUTION

The following procedures could cause the actuator to reposition, which can adversely affect the process and cause potentially dangerous conditions.

Configure the LOS threshold:

HART method

Command: DemLimLwr
Enter "0.00" to "12.00" mA. Decimal value of the lower threshold for detecting LOS. (e.g., the typical value for a 4–20 mA system is "3.20").

DD Menu Location: MENU 4D
Functions>Configuration>Demand Setup>

Serial command method

Command: demlos ###

Arguments: ### Enter the desired Demand signal in mA below which LOS occurs (e.g., the typical value for a 4–20 mA system is "3.20").

Configure the LOS mode:

HART method

Command: LOS Mode

DD Menu Location: MENU 4D
Functions>Configuration>Demand Setup>

Selections:

Stay - select if the actuator should hold output shaft position when a loss of signal occurs.

Go-to-Pos - select if the output shaft should go to a specific position when a loss of signal condition occurs. Configure the position with LOS Pos.

Serial command method

Command: demlos *n*

Arguments: *n* Enter the desired mode

sip: (actuator will stay in place).

gtp: (actuator will go to position set in "demlogtp" command)

pat: (same as "sip", but suppresses the alarm).

Configure the LOS position when Go-to-Pos is selected:

HART method

Command: LOS Pos
Enter "-5.00%" to "105.00%". The percentage of full travel the actuator will move upon LOS.

DD Menu Location: MENU 4D
Functions>Configuration>Demand Setup>

Serial command method

Command: demlogtp ###.###

Arguments: ###.### Desired position of actuator if "gtp" is selected in "demlos". Position is expressed as a percentage of actuator travel in decimal form (e.g., 50% = "50.00").

Command: demlogtp delay *n*

Arguments: *n* Time delay in seconds before the actuator will move to the position set in "demlogtp" (0 to 25.5 seconds). Default is "0".

Entering this command without an argument will return the present GTP and delay settings.

Split Range Operation

It is sometimes desirable or necessary to have more than one final control element controlling a single process. Often, this type of control strategy requires that two to four Beck actuators each respond to different portions of one 4–20 mA Demand signal from the control system.

This type of operation is called split range operation. For example, consider the most common split range scenario—two actuators split ranged for 50% of the 4–20 mA Demand signal input. Both actuators are wired in parallel to receive the same 4–20 mA signal (note that the 250 Ohm R11 resistor (see DCM-3 illustration on page 16) must be removed from one of the two actuator DCM-3 boards to allow HART® communications. If more than two actuators are split ranged, the R11 resistor must be removed from all the DCM-3 boards but one), but each actuator's interpretation of the signal must be different. One actuator must interpret 4–12 mA as 0–100% Demand, and one actuator must interpret 12–20 mA as 0–100% Demand. This requires that the actuators have different Demand signal calibrations.

To set up a split range operation, follow the steps listed below (see page 19 for location of pushbutton controls).

NOTE: Ensure that the L.O.S. (Loss of Demand input signal) settings of the actuators are appropriate for the configuration. See previous page for information on changing L.O.S. settings.

Pushbutton method

1. Apply the desired 0% Demand input signal to the actuator. (Following the example above, the minimum signal for the first actuator would be 4 mA. The second actuator's minimum signal would be 12 mA).
2. Press and hold the “CALIBRATE” pushbutton then press the “SET DEM 0%” pushbutton until the “ACKNOWLEDGE” LED is lit.
3. Apply the desired 100% Demand input signal to the actuator. (Following the example above, the maximum signal for the first actuator would be 12 mA. The second actuator's maximum signal would be 20 mA)
4. Press and hold the “CALIBRATE” pushbutton then press the “SET DEM 100%” pushbutton until the “ACKNOWLEDGE” LED is lit.

5. Repeat this process for all actuators that need to be split ranged, calculating the proper 0% and 100% Demand limits for each actuator as necessary.

HART method

Command: DemRngLwr

Enter the desired 0% Demand signal (in the example above, "4.00" or "12.00" mA).

Command: DemRngUpr

Enter the desired 100% Demand signal (in the example above, "12.00" or "16.00" mA).

DD Menu Location: MENU 4D

Functions>Configuration>Demand Setup>

Serial command method

Command: dem0pctma #.##

Arguments: #.## Desired 0% Demand signal (in the example above, "4.00" or "12.00" mA).

Command: dem100pctma #.##

Arguments: #.## Desired 100% Demand signal (in the example above, "12.00" or "16.00" mA).

CONFIGURATION/CALIBRATION

DEMAND CHARACTERIZATION CURVES

The DCM-3 can be configured to interpret the applied Demand signal for linear or non-linear output shaft position response. Three predefined Demand signal response curves are available for use including: Linear, Square, and Square Root. A chart of each of these predefined responses is provided for your reference.

In addition to the three predefined characterizer curves, the DCM-3 also allows a custom user-defined curve to be configured. This option is called "Dem Curve Spcl".

The Demand characterization curve type can be configured using the following methods.

Change the Demand characterization curve:

HART method

Command: Dem Curve

DD Menu Location: MENU 4D

Functions>Configuration>Demand Setup

Selections:

Linear - select if the actual position % should match the applied Demand %.

Square Root - select if the actual position % should match the square root of the applied Demand %.*

Dem Curve Spcl - select if a user-defined response is desired (see characterization on the following page to define the desired response curve).

Square - select if the actual position % should match the square of the applied Demand %.

Serial command method

Command: demfunc *n*

Arguments: *n* Enter the integer that represents the desired Demand signal response as follows:

0: Linear - select if the actual position % should match the applied Demand %.

1: Square Root - select if the actual position % should match the square root of the applied Demand %.

4: Special Curve - select if a user-defined response is desired (see characterization on the following page to set the desired response curve).

5: Square - select if the actual position % should match the square of the applied Demand % (e.g., "demfunc 0" sets the actuator to a linear Demand response).

DEMAND SIGNAL RESPONSE CURVES

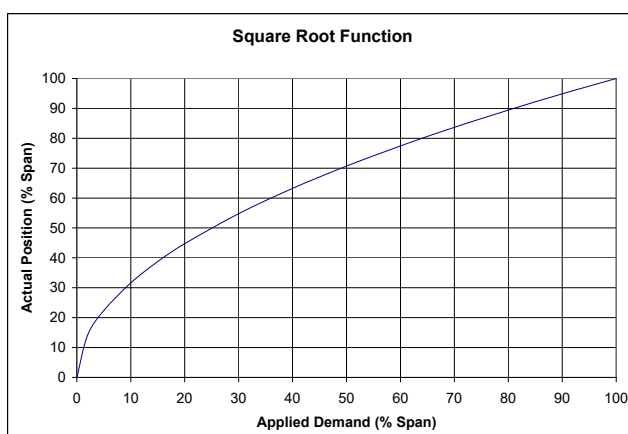
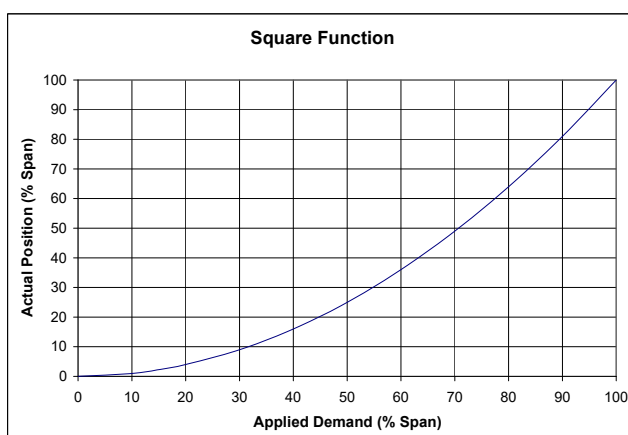
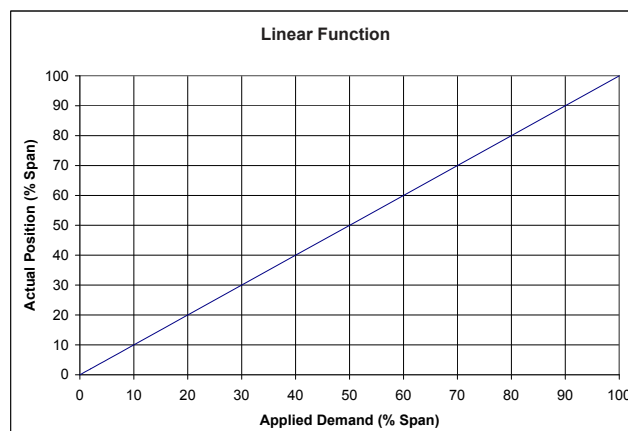

***NOTE**

Implementing a square root characterization creates extremely high gain when the Demand signal is below 10%; this causes instability and is unsuitable for control at this level. Do not apply this curve if the control loop may need to modulate at the lower range of travel.

USER-DEFINED CHARACTERIZATION

Special curves may be created from up to 20 segments, each of which has a node for a starting point and a node for an ending point. All 20 segments do not have to be used, but the used segments must be grouped together starting with segment 1. Segments cannot be skipped.

A node is a coordinate comprised of an X,Y point. When defining nodes, X-values and Y-values must increase as the node number increases. For example, the X-value and Y-value of node 2 must be higher than the X-value and Y-value of node 1. Nodes cannot be skipped. Always start at node 1.

Unless otherwise specified, the Special curve ships from the factory defined as a linear function (i.e., one segment beginning with node 1 at X = 0%, Y = 0% and ending with node 2 at X = 100%, Y = 100%). X-values are typically chosen to give a reasonable spacing in Y-values.

The customer may specify a custom characterization by entering X- and Y-value pairs to define line segments between 0% and 100%.

For example, the table at right uses 5 segments to approximate the square function curve (i.e., $y=x^2$). Segments 1 through 5 are needed, so nodes 1 through 6 are used.

The following methods can be used to configure a user-defined characterization curve.

Change the user-defined characterization:

HART method

Command: DemNode1X

Enter desired X-value as a percentage for node 1

Command: DemNode1Y

Enter desired Y-value as a percentage for node 1

Repeat above procedures for each node required.

DD Menu Location: MENU 5A

Functions>Configuration>Demand Setup>Dem Curve Spcl

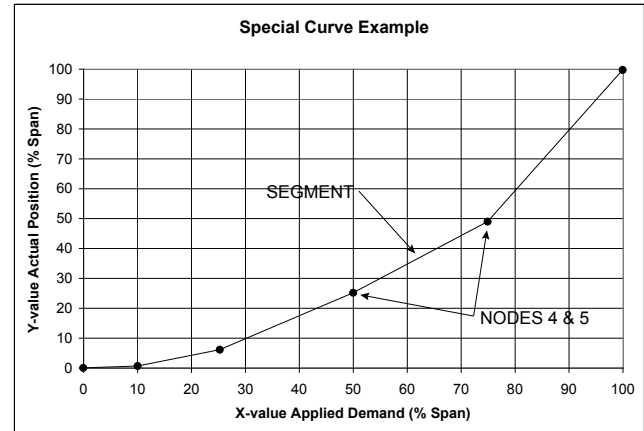

NODE	X-VALUE (DEMAND) % SPAN	Y-VALUE (POSITION) % SPAN
1	0%	0%
2	10%	1%
3	25%	6%
4	50%	25%
5	75%	49%
6	100%	100%

Serial command method

Change the user-defined characterization:

Command: charset *n1*, *n2*, *n3*

Arguments: *n1*, *n2*, *n3*

Where:

n1 = node number.

n2 = X-value as a percentage.

n3 = Y-value as a percentage.

Values must be separated by commas as shown.

Repeat procedure for each node required.

View the user-defined characterization:

Command: charlist ###

Arguments: ### Enter node number between 1 and 21 or "all".

Displays defined nodes.

Clear the user-defined characterization:

Command: charclear ###

Arguments: ### Enter node number between 1 and 21.

Clears a defined node by setting it to unused.

Will also clear any node numerically higher.

CONFIGURATION/CALIBRATION

POSITION FEEDBACK SIGNAL

DCM-3 control electronics provide a 4–20 mA analog output signal that represents the actuator output shaft position. The DCM-3 monitors an internal position voltage from the CPS-5, controls the actuator position, and sources a 4–20 mA signal to terminals DD (–) and EE (+). The Feedback will correspond with the 0% and 100% output shaft positions, as determined by the position calibration. **There is no need for separate Feedback calibration.**

The user has the option of enabling or disabling the position Feedback signal. The factory default configuration will have the Feedback enabled. When the Feedback is enabled, but not in use (i.e., not wired to a load) the "STAT" and "FB OPEN" LEDs will illuminate. This status alarm is helpful in alerting the user to open Feedback wiring, but can be a nuisance when the Feedback is purposely disconnected or unused. Disabling the Feedback signal turns off the output and eliminates the status alarm. If HART or Serial communications are not immediately available to disable the Feedback signal, you can apply a 250 ohm load resistor across the Feedback terminals DD (–) and EE (+) to simulate a Feedback loop and eliminate the alarm.

Use the HART or Serial Commands (detailed on the next page) to set the Feedback signals and corresponding output shaft positions as detailed below.

If desired, the milliamp position Feedback values for 0% and 100% positions can be configured differently than the respective standard factory calibration of 4 mA and 20 mA. A valid 0% position Feedback signal value can be configured anywhere in a 3–16 mA range, while a 100% signal value can be configured from 7–21 mA. The 100% milliamp value must exceed the 0% value by at least 4 mA.

Also, reversed (decreasing direction) Feedback may be selected so that the position resulting from a 4 mA Feedback signal corresponds to the position typically resulting from a 20 mA signal; e.g., 4 mA = 100% position and 20 mA = 0% position. Setting the 0% position to 20 mA will automatically set the 100% position to 4 mA (and vice-versa), and will activate the reverse (decreasing) Feedback function. After accepted, these settings may then be changed as detailed in the paragraph above, only opposite; i.e., a valid 0% position Feedback value is 7–21 mA, while a 100% position may be set at 3–16 mA. The difference between the values can be no less than 4 mA and no greater than 18 mA.

The factory calibrated relationship between the position Feedback signal and the output shaft position is linear (i.e., 0% to 100% Feedback signal corresponds directly with 0% to 100% shaft position). This relationship is suitable for most applications; however, the Feedback to Demand relationship can be changed to compensate for characterized Demand signals. This relationship is called "Inverse Demand". Configuring this option allows the position Feedback signal to match the uncharacterized Demand signal rather than true output shaft position.

The following example assumes 4–20 mA Demand and position signals. If the Demand is set to a square characterization, then a 12 mA Demand corresponds to 25% position. If the position Feedback curve is set to linear, then Feedback at 25% is 8 mA. For some control systems, having the Demand at 12 mA and the Feedback at 8 mA may cause a deviation alarm. The Feedback curve can be set to "Inverse Demand" so the Demand and Feedback match when the actuator is balanced. In this example, with Feedback set to "Inverse Demand" and the output shaft position at 25%, the Feedback signal would be 12 mA.

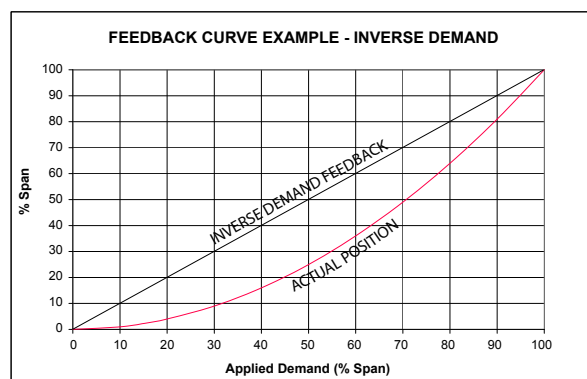
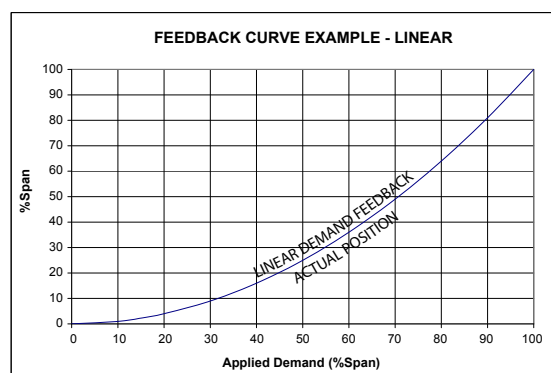

The following methods describe how to enable or disable position Feedback, set the 0% and 100% milliamp values and select the desired Feedback response.

Enable/disable the position feedback:

HART method

Command: Feedback

DD Menu Location: MENU 4E

Functions>Configuration>Feedback Setup>

Selections:

Enabled - to enable position Feedback.

Disabled - to disable position Feedback.

Serial command method

Command: iomode *n*

Arguments: *n*

0: Feedback disabled.

1: Feedback enabled.

Set the feedback range lower and upper values:

HART method

Command: FB RngLwr

Enter the milliamp value that corresponds with 0% position. Acceptable range "3.00"–"16.00" (typically, "4.00").

Command: FB RngUpr

Enter the milliamp value that corresponds with 100% position. Acceptable range "7.00"–"21.00" (typically, "20.00").

DD Menu Location: MENU 4E

Functions>Configuration>Feedback Setup>

Serial command method

Command: fdbk0pctma #.##

Arguments: #.## Desired Feedback signal in mA at 0% output shaft position. The value limit may be no less than "3.00" or, if reversed (decreasing direction), no greater than "21.00".

Command: fdbk100pctma #.##

Arguments: #.## Desired Feedback signal in mA at 100% output shaft position. The value limit may be no greater than "21.00" or, if reversed (decreasing direction), no less than "3.00".

Set the feedback characterization curve:

HART method

Command: FB Curve

DD Menu Location: MENU 4E

Functions>Configuration>Feedback Setup>

Selections:

Linear - to enable a linear feedback signal

InvDem - to enable an inverted Demand feedback signal.

Serial command method

Command: fdbkfunc *n*

Arguments: *n*

0: Linear Feedback signal.

1: Inverse Demand Feedback signal.

CONFIGURATION/CALIBRATION

TEMPERATURE SENSING

DCM-3s are equipped with an internal temperature sensing circuit. The real-time temperature and the historical temperature extremes (low and high) are available.

Temperature units can be selected to show either Fahrenheit or Celsius.

An alarm condition initiates if the actuator's real-time temperature falls outside of the actuator rating—the STAT LED and the TEMP F LED will light, and will automatically reset when the temperature is once again within the actuator rating.

View real-time temperature & historical extremes:

HART method

Command: Temp

Displays the real-time temperature as read by the DCM-3.

DD Menu Location: MENU 1

Command: High Temp

Displays the historical high temperature.

Command: Low Temp

Displays the historical low temperature.

DD Menu Location: MENU 3D

Functions>Statistics

Serial command method

Command: temperature

Arguments:

When entered with no argument, the command returns the real-time temperature as well as the historical high and low temperatures.

Set temperature units:

HART method

Command: Temperature Unit

DD Menu Location: MENU 4B

Functions>Configuration>General Setup

Selections:

degF - Set the temp. units to degrees Fahrenheit.

degC - Set the temp. units to degrees Celsius.

Serial command method

Command: temperature *n*

Arguments: *n*

F: Set the temp. units to degrees Fahrenheit.

C: Set the temp. units to degrees Celsius.

STALL PROTECTION

The DCM-3 board provides protection for the actuator in the event of a stall. Stall protection is activated when the actuator is unable to achieve the proper position within a defined stall time due to a mechanical impediment or excessive load.

The DCM-3 senses when the motor moves the output shaft in one direction longer than the configured "stall time". The DCM-3 then shuts off power to the motor, preventing further actuator movement. When the stall condition occurs, the STAT LED will illuminate.

Resetting due to a stall condition is achieved by reversing the Demand signal, cycling the actuator power, or submitting a reset command via HART or Serial port.

The stall protection feature can be enabled or disabled and the stall time may be configured between 30 and 450 seconds. This feature is factory enabled and the default setting is 300 seconds. If reconfiguring, it is advisable to configure the stall time with a value greater than the maximum stroke time to avoid false stall protection events and alarms.

Enable / disable stall protection:

HART method

Command: StallProt

DD Menu Location: MENU 4B

Functions>Configuration>General Setup>

Selections:

Enabled - to enable stall protection.

Disabled - to disable stall protection.

Serial command method

Command: stallprot *n*

Arguments: *n*

0: stall protection disabled.

1: stall protection enabled.

Configure the stall time:

HART method

Command: Stall Time

Enter the stall time in seconds. Valid stall times are 30 to 450 seconds.

DD Menu Location: MENU 4B

Functions>Configuration>General Setup>

Serial command method

Command: stalltime ###

Arguments: ### Enter the stall time in seconds. Valid stall times are "30" to "450".

Reset a stall condition:

HART method

Command: Reset Stall

Select to reset a stall condition.

DD Menu Location: MENU 3E

Functions>Manual Operation>

Serial command method

Command: unSTALL

Enter to reset a stall condition.

MAINTENANCE

MOTOR ASSEMBLY

The control motor is not field-repairable. **Do not disassemble the motor.** Disassembly of the motor will result in a loss of torque that can only be restored by returning the motor to the factory for re-magnetizing.



WARNING
Disconnect power before proceeding.
Before removing the motor assembly, block the valve stem to prevent the gear train from moving when the motor is removed.

REMOVE THE MOTOR ASSEMBLY:

Disconnect the motor wires in the terminal compartment of the actuator. Access these wires by first removing the four screws holding the terminal board in place. Lift the terminal board to access the solder posts underneath.

Cut the black wire from the terminal "B" post, cut the green motor wire near the green-yellow-red butt joint and disconnect the red wire from the red-green-blue butt connection. Remove the three 10-32 socket head cap screws that secure the motor. Carefully slide the motor out of the actuator body.

INSTALL THE NEW MOTOR ASSEMBLY:

First, insert the three-wire sleeve through the wire hole in the motor mount and into the terminal compartment. Carefully slide the motor into the actuator body. Rotate the motor shaft, if necessary, to engage the pinion with the first combination gear. Install the provided new motor assembly mounting screws (torque the three 10-32 screws to 20 lb-in (2.26 N•m)).

NOTE: 14-109 models with 4 and 8 second timing have a spacer between the motor and gear module.

Reconnect the motor wires to the locations where the old motor wires were cut earlier (per your actuator specific wiring diagram under the terminal compartment cover).

Replace the terminal board. Tighten the four screws to 3 lb-ft (4 N•m).

MOTOR RESISTOR AND CAPACITOR NETWORK

There is no recommended replacement interval for the resistor assembly or capacitor. Nonetheless, it may be advisable to replace these parts as a preventative measure when motors are replaced on older actuators; this is why they are recommended spare parts.

The resistor / capacitor values and part numbers for each motor assembly are shown in the "MOTORS, CAPACITORS, AND RESISTORS" table on page 39. The resistor and capacitor are located in the top compartment beside the Calibar.



WARNING
Electrical shock hazard. Disconnect power before proceeding.

To replace a resistor or capacitor, remove the top cover (15/16" bolt head). Remove the existing part and transfer the wires one at a time to the replacement part. Inspect the top cover gasket and replace if necessary (see "GASKETS", page 35). Replace the top cover. Tighten the top cover bolt just enough to compress the O-ring seal.

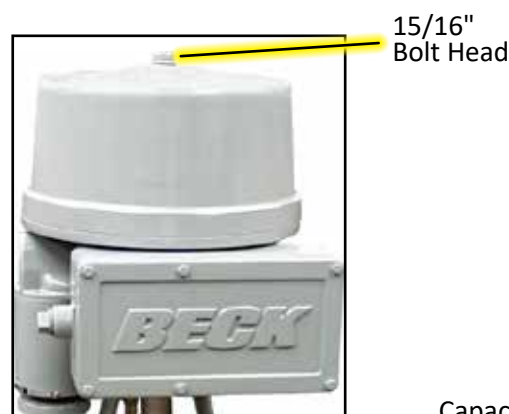

15/16"
Bolt Head

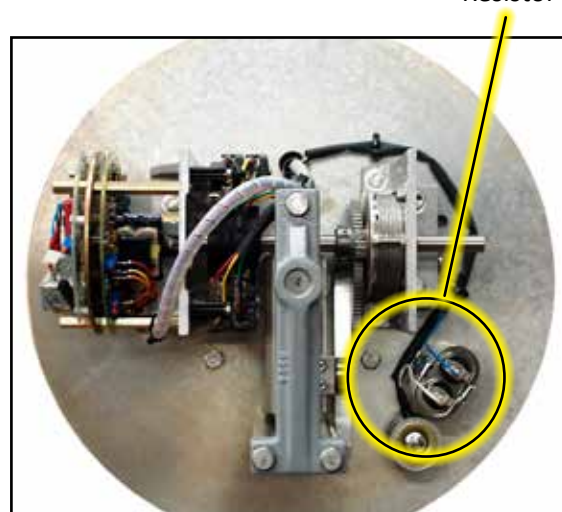

Capacitor &
Resistor

The Beck Group 14 actuator requires only minimal routine maintenance. Periodic visual inspections are recommended to verify that the connection to the valve is intact and operating normally. If vibration is present, check the electrical terminal connections and other hardware for tightness.

LUBRICATION

Periodic lubrication is not required on Beck actuators. However, during major maintenance outages, it is recommended that older actuators should be inspected to ensure that the gearing is not worn or damaged.



WARNING	
Disconnect power before proceeding.	Before removing the gear housing assembly, block the valve stem to prevent the gear train from moving when the housing assembly is removed.

To inspect or lubricate the output gear only, remove the cover plate (1/2" bolt heads) on the side opposite the motor. The output gear is not field replaceable.

To inspect all the gears, first remove the motor from the housing, following the instructions on the previous page. Then, remove the housing assembly from the body (1/2" bolt heads). Clean all parts thoroughly, removing as much old lubrication as possible. Examine the gear teeth for signs of excessive wear, scoring, or other damage. Check for excessive free play of gears on shafts. The assembly is not field repairable and should be returned to the factory if damage or excessive wear is noted.

Before reassembly, recoat the teeth with a heavy layer of Fiske Lubriplate GR-132 or equivalent. GR-132 is an E.P. grease with polymer additives.

To reinstall the gear housing, carefully position the housing on the body's alignment pins. Replace the bolts and tighten to 10 lb-ft (13.5 N•m).

Reattach the motor per the instructions on the previous page.

GASKETS

During routine service, inspect the gaskets and O-rings for wear or damage. In order to protect internal components, worn or damaged gaskets and O-rings should be replaced.

To remove the main gear cover, terminal compartment, or the motor gaskets, scrape all of the old adhesive and gasket material from the body housing and cover. Cement the new gasket to the actuator body using a gasket cement such as 3M #847 Rubber and Gasket Adhesive, or equivalent.

O-ring seals are used between the body and the top and bottom bearing plates. Before installing a new O-ring, lubricate it with light machine oil.

The large top cover is sealed with rubber foam gasket material, 5/16" (8 mm) in diameter. To replace this material, scrape the old gasket material and cement from the groove. Cement the new foam gasket into the groove with 3M #847 Rubber and Gasket Adhesive, or equivalent. Cut the ends of the material on an angle and cement them together with this same adhesive.

SEALS

Worn or damaged output shaft and motor shaft seals should be replaced to prevent damage to internal bearings and actuator train parts.

To remove the shaft seal, push the blade of a small screwdriver along the shaft and under the seal lip.



CAUTION	
The seal is approximately 1/4" wide. Do not force the screwdriver blade beyond the width of the seal; damage to the shaft bearing could result.	

Pry up on the seal and force it out of the housing. Clean the shaft and housing and press in the replacement seal with the closed side facing outward.

BEARINGS

There are some field replaceable bearings in the Group 14 actuator. Consult the factory for details.

MAINTENANCE

OVER-TRAVEL LIMIT AND AUXILIARY SWITCHES

Complete switch assemblies may be replaced. It is not possible to replace individual switches.



WARNING

Electrical shock hazard. Disconnect power before proceeding.

To replace switch assemblies, remove the top cover (15/16" bolt head). Remove the #6-32 socket head cap screws holding the switch assembly to the plate.

Transfer the wires one at a time to the replacement assembly using the push-on lugs provided. Install the replacement assembly and note that it rotates around one screw to permit an adjustment of the cam-to-roller spacing and switch operating point. To properly set the switch, use a .030" (.76 mm) shim between the cam and switch lever and loosely position the switch assembly so that the switch is just actuated. The switch lever should be on the low or minimum radius portion of the cam when setting the switches. DO NOT overstress the switch lever. Tighten both screws to 10 lb-in (1.13 N•m) torque and remove the shim. When properly adjusted, the switch lever should remain in contact with the cam throughout actuator travel.

ADDING SWITCHES

It is possible to add two additional switches to an actuator in the field. Consult the factory, giving the actuator model and serial number so that a correct list of parts required may be supplied to you.

Remove the top cover (15/16" bolt head). Install wiring onto the switch push-on lugs and route the wires into the actuator terminal area. Remove the terminal cover and solder wires to the underside of the terminal assembly according to the wiring diagram included with the new switch assembly. Install the new switch assembly and adjust according to the instructions above. See table on page 39 for switch assembly part numbers.

SELF-LOCKING MECHANISM (SLM)

In normal service, the SLM friction surface should not require replacement; however, a combination of excessive modulation and load can cause wear to the SLM mechanism. If the SLM has been damaged, rebuild kits are available (see table below).

SLM Rebuild Kits typically consist of a spring, spring pin, thrust bearing, pinion, steel balls, locking disc, steel shims, control motor gasket, terminal joints, friction material liner and instruction sheet.

See the figure below for identification of typical SLM components.

SLM KIT PART NUMBERS

Motor Part Number	SLM Rebuild Kit GL181-134	Instruction Sheet
20-2702-31	12-8067-19	80-0016-09
20-2703-31	12-8067-19	80-0016-09
20-2703-34	12-8067-20	80-0016-09

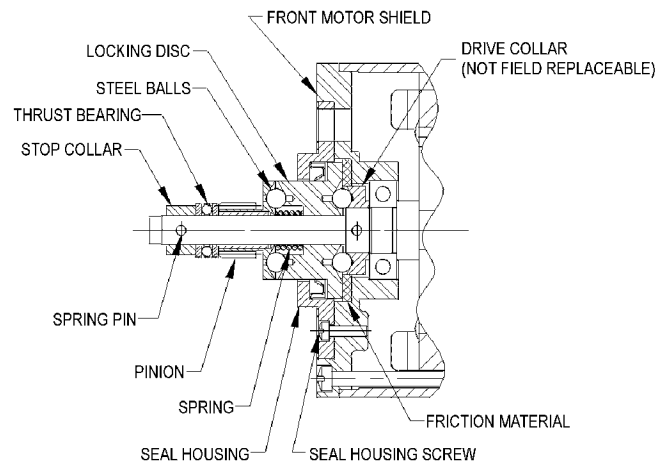

SLM Detail

Handswitch

To replace the Handswitch, remove the terminal cover, DCM-3 board and DCM-3 bracket. Clip the five wires from the old Handswitch. Remove the knob and the nut under the knob to remove the switch. Install the new Handswitch as shown in the figure below. Splice the wires color for color. Replace the DCM-3 bracket, board and the terminal cover. Torque bolts to 10 lb-ft (13.5 N•m).

NOTE: The AUTO position on the Handswitch knob must be straight up when the switch is fully clockwise. Handswitch part number 20-3300-27.

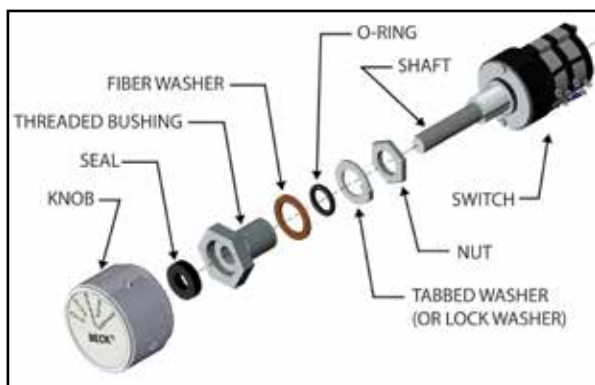

DCM-3

Field service of the DCM-3 board is not recommended. The factory maintains a stock of replacement boards for immediate shipment.



WARNING

Electrical shock hazard. Disconnect power before proceeding.

To replace the DCM-3 board, remove the terminal compartment cover (1/2" bolt heads). Loosen the four captive thumb screws holding the board to its mounting pads. Note the "L" shaped mounting bracket on the end of the board. To remove the board, pull the mounting bracket away from its mating surface with a gentle rocking motion.

To install a DCM-3 board, lightly press the board connector into its receptacle until the mounting bracket is flush with its mounting surface. Tighten the four captive thumb screws and replace the compartment cover. Torque cover bolts to 10 lb-ft (13.5 N•m).

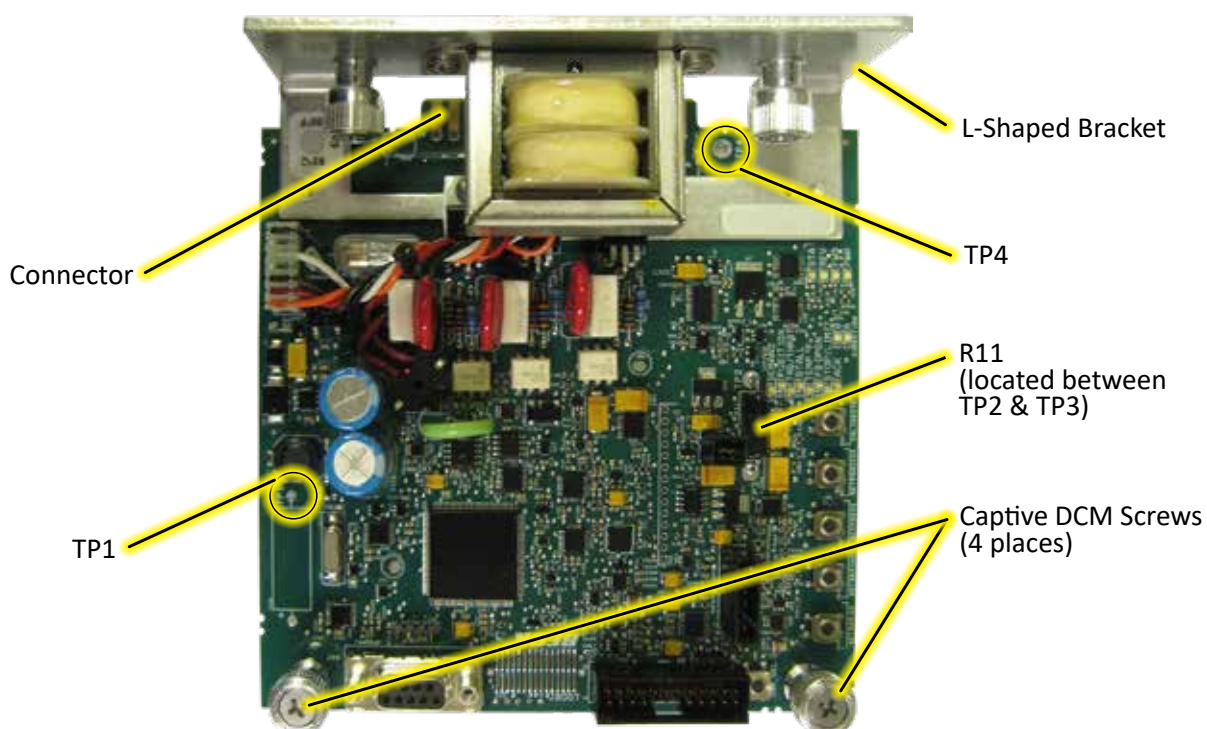

DCM-3

MAINTENANCE

CPS-5

Field repair of the CPS-5 is not recommended.



WARNING

Electrical shock hazard. Disconnect power before replacing the CPS-5.

To replace the CPS-5, both the rotor and stator/circuit board assembly should be replaced. When returning the CPS-5 to the factory for service, do not separate the rotor and stator/circuit board assemblies from their mounting plates. The rotor should be held inside the stator with rubber bands when shipping.

The CPS-5 is configured to produce a position signal voltage from 1 to 5 volts over full range of travel.

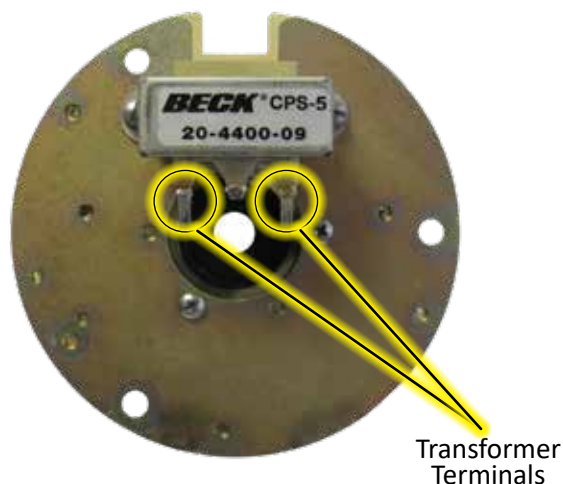

CPS-5 Transformer

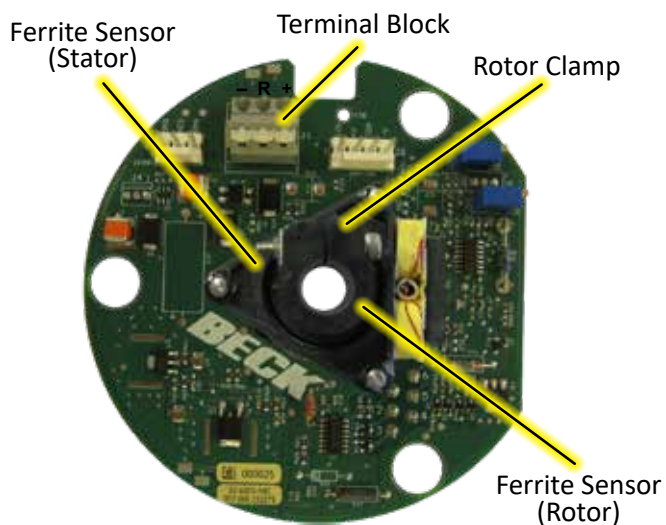

CPS-5 Transducer Board

REMOVE THE EXISTING CPS-5 ASSEMBLY:

1. Run the actuator to its midpoint of travel with the local Handswitch.
2. Disconnect power from the drive. Remove the DCM-3 compartment / terminal cover (1/2" bolt heads) and top cover (15/16" bolt head).
3. Record the wire colors on the terminal block of the CPS-5 (see illustration this page), then disconnect the wires. The terminals are spring-loaded. To remove a wire, press the tip of a small screwdriver into the slot at the top of the small lever. Push down to open the spring-loaded contact and release the wire.
4. Pull the wires from the transformer back through the wire hole in the CPS-5.
5. Loosen and remove the 3 hex studs that hold the CPS-5 in place. Ensure that the inboard hex stud is not loosened as the outboard stud is loosened.
6. Slide the CPS-5 stator assembly off the three mounting bolts.
7. Note the position of the rotor clamp, then loosen the rotor clamp screw and remove the rotor from the shaft.

INSTALL THE NEW CPS-5 ASSEMBLY:

8. Remove the rotor from the replacement CPS-5 assembly. Slide the rotor, clamp end first, onto the control shaft as close to the mounting plate as possible. Leave the clamp loose. Position the clamp in the same general location as the one removed previously.
9. Slide the new CPS-5 assembly over the studs and rotor. Replace the hex nuts but do not tighten. Carefully slide the rotor back into the CPS-5 assembly. Twist the rotor while sliding to prevent damage to the assembly. Tighten hex nuts to 5 lb-ft (7 N•m).
10. Thread the wires through the wire holes in the CPS-5 and reconnect them to the transformer and terminal block.
11. Restore 120 V ac power to the actuator and connect a meter to the output.
12. Insert a 0.031" (.80 mm) feeler gauge between the rotor clamp and stator. Position the clamp 0.031" (.80 mm) from the stator.
13. Rotate the rotor (only a minor adjustment should be necessary) on the control shaft until the output voltage measured across TP4 and TP1 (see photo on page 18) reads 50% (approx. 3 volts) of the signal span. Tighten clamp to 5 lb-in (.6 N•m) torque.
14. Perform the position calibration procedure (page 24).

RECOMMENDED SPARE PARTS

It is recommended that certain replacement parts be stocked for quick availability in the event that service of your Beck actuator is required. The types of parts are listed in the spare parts table below.

HOW TO ORDER SPARE PARTS

Select the needed parts from the spare parts list given below. Specify the actuator's model / serial number (example: 14-109-031891-01-02) given on the nameplate to allow the factory to verify the part selection. Parts may be ordered by mail, telephone or fax, with the confirming order sent to the factory (see back cover).

RECOMMENDED SPARE PARTS

Description	Part Number
DCM-3 board	22-5020-59
Fuse, 7A, 125V (For use on DCM-3)	11-1372-26
CPS-5 assy.	20-4400-09
Fuse, 0.8A, 250V (Model 14-10_, 240V)	11-1370-16

Description	Part Number
Overtravel limit switch assy. 4 switches (RET, EXT, S1, S2)	20-3202-20
Auxiliary switch assy. 2 switches (S3, S4)	20-3202-21
Gasket Kit	20-3110-13
Motor assy., Capacitor, Resistor	See Below

MOTORS, CAPACITORS, AND RESISTORS

Model No.	Motor				Capacitor		Resistor		Use Only With Timing ...	
	Part No.*	Current (Amps at 120 Vac, 60 Hz ^c)	Torque (N•m)	RPM	Freq. (Hz)	Part No.	Value (µf)	Part No.		Value (Ω)
14-109	20-2702-31	.44	1.5	72	60	14-2840-16	5	20-1971-13	220	10 sec. or higher
					50	14-2840-19	7	20-1971-13	220	10 sec. or higher
	20-2703-31	.72	3.0	72	60	14-2840-05	8	20-1971-12	110	10 sec. or higher
					50	14-2840-30	13	20-1971-12	110	10 sec. or higher
	20-2703-34**	.72	3.0	72	60	14-2840-05	8	20-1971-12	110	8 sec. or higher
					50	14-2840-30	13	20-1971-12	110	8 sec. or higher

* Motor replacement part numbers will include the suffix, "-KIT"; e.g., 20-2702-31-KIT.

** It is necessary to install a gear housing spacer with this module.

GEARS

MODEL NO.	SPUR GEAR RATIO / 1	NOMINAL SPEED sec./in. (sec./cm)		GEAR HOUSING ASSEMBLY
		60 Hz 72 RPM	50 Hz 60 RPM	
14-109	4.14	4 (1.6)	5 (2.0)	10-6670-36
	7.90	8 (3.1)	10 (3.9)	10-6670-26
	10.65	11 (4.3)	13 (5.1)	10-6670-24
	15.70	16 (6.3)	19 (7.5)	10-6670-13
	25.90	27 (10.6)	31 (12.2)	10-6670-23
	45.80	48 (18.9)	57 (22.4)	10-6670-07

MAINTENANCE

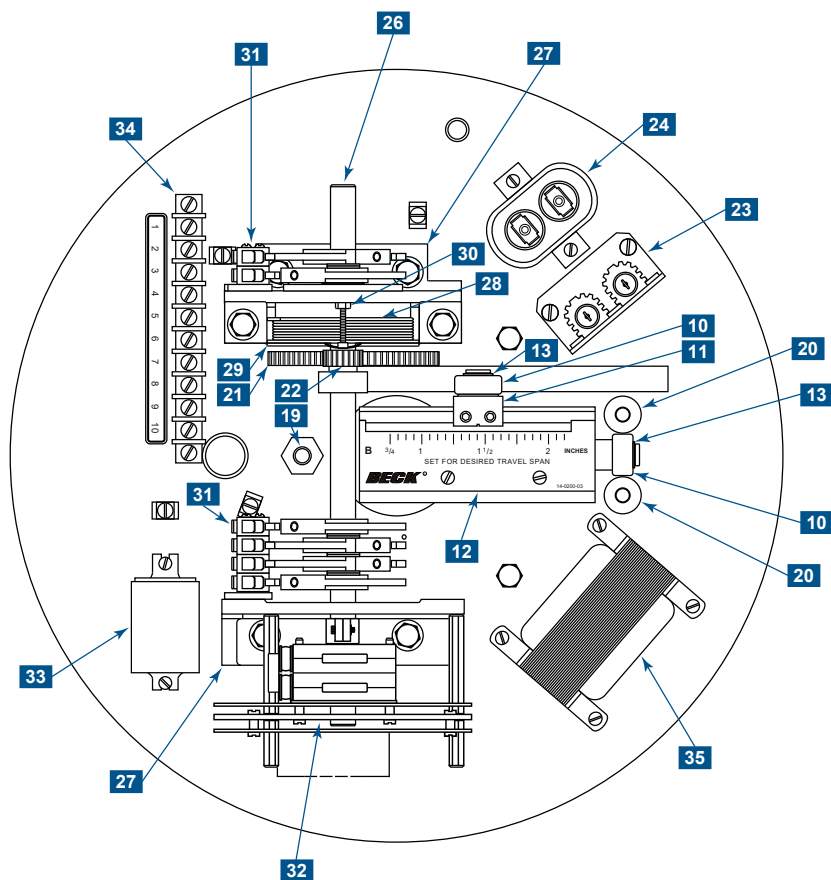

PARTS FOR MODEL 14-109 CONTROL ASSEMBLY AND DRIVE TRAIN

ITEM NO.	DESCRIPTION	ITEM NO.	DESCRIPTION
1	Top bearing plate with bushing and seals	18	Top bar
2	Seal for top bearing plate	19	Hex stud
3	Bottom bearing plate with bushing and seals	20	Guide bar (2)
4	Seal for bottom bearing plate	21	Sector-level gear assembly
5	Maingear assembly	22	Pinion
6	Mainshaft bearing	23	Resistor; select from table on p. 39
7	Cover plate	24	Capacitor; select from table on p. 39
8	Cover plate gasket	25	Tight-sealer
9	Shaft assembly	26	Shaft
10	Ball bearing (2)	27	Bracket (2)
11	Calibar slider	28	Spring
12	Calibar index	29	Mandrel
13	Retaining ring (2)	30	Switch shaft indicator
14	Motor assembly; select from table on p. 39 (sold only as complete assembly)	31	Switches; see table on p. 41
15	Gear housing assembly; select from table on p. 39 (sold only as complete assembly)	32	CPS
16	Top cover with gasket	33	Double-pole, double-throw relay (optional)
17	Top cover bolt	34	Auxiliary terminal strip
		35	Transformer (w/ fuse, if 240V model)

Note: To ensure exact replacement parts, include all nameplate data of the Beck actuator with the order.

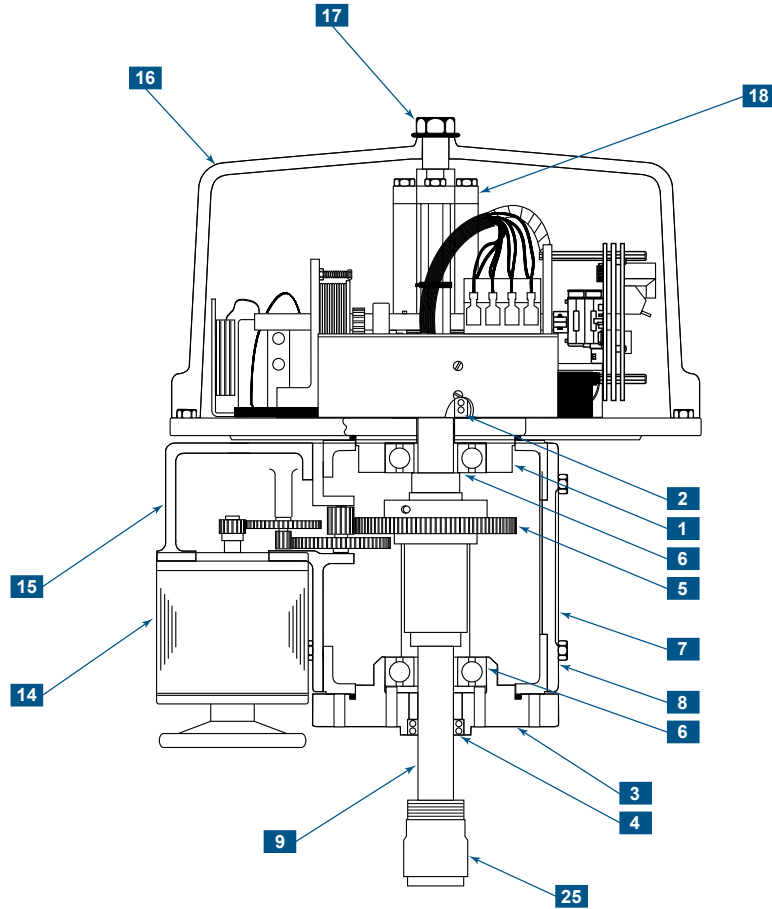

CONTROL ASSEMBLY AND DRIVE TRAIN

TROUBLESHOOTING

The DCM-3 features diagnostics to help troubleshoot problems.

The following list provides a systematic method for isolating any actuator problems.

1. Operating Voltage
2. Handswitch Operation
3. DCM-3 Status Indication LEDs
4. DCM-3 Testpoints
5. DCM-3 Configuration
6. Shaft Position
7. Inhibitors / Statistics

VERIFY OPERATING VOLTAGE

To check the input power supply, view the Overview LEDs on the DCM-3 board (see illustration, page 16). This requires removing the DCM compartment cover (see page 7 for location).

The PWR LED should pulse from dim to bright, which indicates that power is applied to the actuator and the DCM-3 is successfully completing (continuous) self-tests. If the PWR LED is not lit or pulsing, there may be a problem with the AC power supply to the actuator.

Ensure the actuator is receiving the proper operating voltage (listed on the actuator nameplate). To check the voltage, locate the power terminals on the terminal block (see wiring diagram on the underside of the terminal compartment cover). Using a voltmeter, measure the voltage applied to those terminals. If the voltage is correct, continue troubleshooting; if the voltage is not correct, apply the proper power.

CHECK HANDSWITCH OPERATION

Verify proper operation of the Handswitch, which bypasses the actuator control electronics and switches power directly to the motor windings. Operate the actuator in both directions of travel using the Handswitch. If the actuator responds as expected, electro-mechanical problems with the motor and gearing may be eliminated. The trouble may lie with the electronics.

CHECK DCM-3 STATUS INDICATION LEDs

The DCM-3 has seven Status Indication LEDs that provide specific information about the actuator's state (page 17). A lit LED indicates that a condition exists.

CHECK DCM-3 TESTPOINTS

The DCM-3 controls actuator output position by comparing the actuator's Demand input signal with the internal Position feedback signal generated

by the actuator's position sensor (CPS-5). The integrity of these signals is critical to actuator performance. The signals should be verified whenever there are actuator problems. There are four test points provided on the DCM-3 board (see page 16 for locations) that are used to measure the Demand input and internal Position signals directly at the DCM-3.

Measure the Demand signal voltage across TP2(+) and TP3(-). A typical 4–20 mA input signal will measure a proportional 1–5 V dc across the test points. It is important to verify that the measured voltage corresponds correctly to the signal that is being applied. If there is a mismatch, further troubleshooting is required.

The Position signal to the DCM-3 is generated by the actuator's CPS-5. The CPS-5 is designed to provide a 1–5 V dc signal to the DCM-3 corresponding to 100% of actuator output shaft travel. The Position signal can be determined at the DCM-3 by measuring the voltage across TP4(+) and TP1(-). Verify that this signal matches Demand and the position of the output shaft (see chart below).

Both the Demand and Position signals can also be checked at the appropriate terminals in the terminal block, via HART communications or through the Serial port. All values should agree with test point values. Any differences will require further troubleshooting.

CPS-5 POSITION SIGNAL VOLTAGES

Shaft Position	RET	EXT
0%	1.0	5.0
25%	2.0	4.0
50%	3.0	3.0
75%	4.0	2.0
100%	5.0	1.0

CHECK DCM-3 OPERATION MODE SETTING

The DCM-3 can be configured for several operational modes as shown in HART menu 3E (page 51) or Serial command "opmode" (page 59).

The factory configuration is the "Follow" mode. In this mode, the actuator is positioned by the 4–20 mA Demand signal when the Handswitch is set to AUTO.

The "Hold" mode causes positioning according to the HART Interface Demand Value (HART menu 3E).

The "Stay" mode causes the output shaft to remain stationary and maintain its present position.

In "Stay" mode, the Handwheel cannot be freely turned as it will move back to the position where the "Stay" mode was activated.

The "Stop" mode removes power from the motor. In "Stop" mode the Handwheel can be freely turned. All operating modes can be overridden by the actuator Handswitch. If the operation mode is (inadvertently) switched to a mode other than "Follow" there will not be an outward indicator.

Note that resetting the DCM-3 to factory settings does not change the operational mode back to "Follow" for safety purposes.

CHECK SHAFT POSITION

The output shaft position (%) can be viewed in HART (menu 1) or by running the Serial command "stat".

If the Position value (%) does not appear to match the physical output shaft position, a CPS-5 rotor adjustment may be required. Follow these directions to correct positioning (see page 40 for component identification):

1. Rotate the rotor on the control end shaft until the dc voltage measured across terminals + and R reads 50% of the signal span (approx. 3 volts). Tighten clamp to 5 lb-in (0.6 N•m) torque.
2. Using the Handswitch, retract the output shaft of the actuator. The dc voltage measurement across the + and R (–) terminals should increase, in which case the rotor adjustment is complete. If the voltage decreases, however, the rotor is out of phase with the actuator travel and will require adjustment, continue to step 3.
3. Position the actuator with the Handswitch until the voltage reading across terminals + and R (–) is approximately 3 volts.
4. Loosen the rotor clamp screw and rotate the rotor 180 degrees. Verify the voltage is 3.0 volts and tighten the rotor clamp screw. Repeat step 2.

Note: The position signal can also be measured across DCM-3 test points TP4 (+) and TP1 (–) rather than CPS-5 terminals (+) and R (–).

CHECK DCM-3 INHIBITORS / STATISTICS

Conditions that prevent the DCM-3 from positioning the actuator are called inhibitors. HART MENUS 5F and 5G list the RET and EXT inhibitors respectively. Inhibitors may also be reviewed by running the Serial command "stat" (see page 60). The following list indicates why the inhibitor would be in the "ON" state.

Balance

Demand and position are balanced.

Supervisory

DCM-3 is initializing.

Stall

A stall condition has been detected.

OverTrq/Thr

Not installed on Group 14 actuators.

Switch Block

Handswitch, Override or Limit Switch is inhibiting movement.

Bad Pos Sig

The Position signal is out of range.

Bad Dem Sig

The Demand signal is out of range.

Local Cal

The calibrate button is being pressed on the pushbutton panel.

The factory can assist with troubleshooting—please provide the results of the above review to expedite assistance.

TROUBLESHOOTING

CONDITIONS	POSSIBLE CAUSES	CORRECTIONS
1. No DCM-3 LEDs are illuminated.	<ul style="list-style-type: none"> a. No power is applied to the actuator. b. Incorrect power is applied to the actuator. c. Main power fuse/breaker is blown. d. DCM-3 malfunction. 	<ul style="list-style-type: none"> a. Apply operating voltage to the operating voltage terminals. b. Verify correct voltage on actuator nameplate and ensure that it is applied at the operating voltage terminals. c. Verify fuse/breaker integrity. Replace/reset if blown. Find cause of short circuit. d. Replace DCM-3.
2. STAT LED is illuminated.	<ul style="list-style-type: none"> a. A status alarm is active. 	<ul style="list-style-type: none"> a. Check the status indication LEDs on the pushbutton interface of the DCM-3. Continue troubleshooting based on the LEDs that are illuminated.
3. Demand LED is illuminated.	<ul style="list-style-type: none"> a. No Demand signal. b. Applied Demand signal is outside of configured range. c. Polarity of applied signal wires is reversed. 	<ul style="list-style-type: none"> a. Apply Demand signal to terminals AA (+) & BB (-). b. Confirm Demand signal value via HART or by measuring DC voltage across DCM-3 test points TP3(+) & TP2(-). Should be 1–5 volts for 4–20 mA applied signal. c. Correct the polarity of the applied control signal wires on terminals AA (+) & BB (-).
4. POSITION LED is illuminated.	<ul style="list-style-type: none"> a. Position signal voltage generated by CPS-5 read by the DCM-3 is outside of the configured range. b. CPS-5 malfunction. c. DCM-3 malfunction. 	<ul style="list-style-type: none"> a. Using the HART communicator check the Position Sensor Setup menu to verify the Present CPS voltage falls within the configured CPS Zero% and Span (typical range 1–5 volts); OR measure DC voltage between DCM-3 test points TP4 (+) and TP1 (-) to verify Present CPS voltage. If the voltage is outside of 1–5 volts, recalibrate or replace the CPS-5. b. Replace CPS-5. c. Replace DCM-3.
5. STALL LED is illuminated.	<ul style="list-style-type: none"> a. Actuator has stalled—unable to achieve desired position within the configured “STALL TIME”. b. The configured stall time is less than the configured Max Travel Time. 	<ul style="list-style-type: none"> a. Eliminate the obstruction and reset the stall by reversing direction on Demand signal, cycling the power, or issuing the stall reset from HART or Serial command. b. Configure the stall time to exceed the Max Travel Time via HART or Serial command.
6. TEMP F LED is illuminated.	<ul style="list-style-type: none"> a. The measured temperature at the DCM-3 is outside of the normal operating range of -40° to 185° F. 	<ul style="list-style-type: none"> a. Protect the actuator from the extreme temperatures below or above the operating range to eliminate the alarm.
7. FB OPEN LED is illuminated.	<ul style="list-style-type: none"> a. The position Feedback circuit current loop is not complete. b. The position Feedback is enabled, but not in use. 	<ul style="list-style-type: none"> a. Ensure the device measuring the 4–20 mA Feedback is properly terminated on terminals DD (-) and EE (+) and is applying a 0–800 ohm load resistance. b. Disable Feedback via HART or Serial command; OR terminate the Feedback loop by applying a 0–800 ohm load resistance across terminals DD and EE.

CONDITIONS	POSSIBLE CAUSES	CORRECTIONS
8. STOP/LIMIT LED is illuminated.	<ul style="list-style-type: none"> a. The applied power is below the tolerance (-15%) of the nameplate operating voltage. b. A DCM-3 fuse is open. c. A component failure has occurred on the DCM-3. d. The Handswitch is in STOP. e. The actuator has traveled to an over-travel limit switch. f. The actuator is not at an over-travel limit switch, but the limit switch is open. 	<ul style="list-style-type: none"> a. Apply the correct operating voltage to the actuator per the voltage stamped on the nameplate. b. Replace the open fuse. c. Replace the DCM-3. d. Place the Handswitch in AUTO. e. Verify if the limit switch is set outside of the electrically calibrated limits. Readjust, if necessary, or replace. f. Replace the over-travel limit switch (RET/EXT) assembly.
9. Power LED is pulsing bright to dim.	a. This indicates normal function.	a. No action required.
10. All LEDs are illuminated or flashing.	a. A component failure has occurred on the DCM-3.	a. Replace the DCM-3.
11. REV LED is illuminated, actuator is not moving, and there are no other status alarms.	a. Operation mode is set to "STOP".	a. Using HART (operation mode menu) OR using Serial command "opmode", change operation mode to "Follow".
12. Actuator will not hold position with Handswitch in STOP.	a. Self Locking Mechanism (SLM) is worn or damaged.	a. Rebuild the SLM assembly.
13. Motor runs, but the output shaft does not move in one or both directions.	a. Self Locking Mechanism (SLM) has failed.	a. Rebuild the SLM assembly.
14. PWR LED is flashing, no status LED's are lit and does not respond to Demand signal or Handswitch.	<ul style="list-style-type: none"> a. The Handswitch is damaged. b. The Handswitch jumper between terminal A and C is missing or faulty. 	<ul style="list-style-type: none"> a. Check continuity from terminals N to V and M to U with Handswitch in AUTO position. If either does not show continuity, replace Handswitch. b. Install a wire jumper between terminals A and C.
15. PWR LED is flashing, no status LED's are lit, actuator functions with the Handswitch, but does not respond to Demand signal.	a. A plug-in jumper has been installed in the 24-pin connector (J2) of the DCM-3 board.	a. Remove any jumpers from the J2 connector on the DCM-3.
16. HART communications cannot be established with the DCM-3.	<ul style="list-style-type: none"> a. The device description (DD) file is not installed. b. The HART communicator is not compatible with Beck equipment. c. The HART communications circuit on the DCM-3 is damaged. 	<ul style="list-style-type: none"> a. Install the Beck MK-2 DD on your HART device. b. Utilize a compatible HART communicator or configure the actuator through the Serial port. c. Replace the DCM-3.
17. Position voltage on DCM-3 testpoints TP4 and TP1 is within 1–5 volts DC following the actuator position, but the position Feedback signal at terminals DD and EE remains constant or is erratic.	a. The position Feedback circuit on the DCM-3 is damaged.	a. Replace the DCM-3.

TROUBLESHOOTING

CONDITIONS	POSSIBLE CAUSES	CORRECTIONS
18. Output shaft moves opposite the desired direction when applying a 4–20 mA Demand signal.	a. The travel direction is incorrectly configured.	a. Reconfigure the travel direction using pushbutton, HART, or Serial method.
19. Motor erratic or runs in wrong direction in AUTO or when using Handswitch.	a. Motor winding is open. b. Motor capacitor is shorted or open. c. Motor resistor is open.	a. Replace motor assembly. b. Replace capacitor. c. Replace resistor assembly.
20. Actuator does not follow input signal until maximum or minimum is reached, then drives uncontrollably to limit.	a. Wire jumpers on terminals M and N are reversed. b. CPS-5 is not calibrated.	a. Connect terminal jumpers from M to D and from N to F. b. Recalibrate the CPS-5.
21. Actuator oscillates in AUTO mode.	a. Excessive noise on the input signal. b. Physical obstruction causing a stall condition (e.g., valve jammed or load greatly exceeds actuator rating.) c. The DCM-3 is malfunctioning. d. Excessive wear in the gear train or bearings. e. CPS-5 Failure. f. Self Locking Mechanism (SLM) is worn or damaged.	a. Eliminate noise or increase actuator step size. b. Check operation with Handswitch and remove obstruction if present. Handswitch bypasses the DCM-3 board. c. Replace the DCM-3 board. d. Replace worn actuator parts. e. Replace the CPS-5 board. f. Rebuild the SLM.
22. Actuator will not run in either direction or one direction in AUTO or using Handswitch.	a. Over-travel limit switch failure. b. Handswitch failure.	a. Replace over-travel limit switch assembly (RET/EXT). b. Replace Handswitch assembly.
23. Actuator does not stop at normal or desired limit of shaft travel.	a. DCM-3 position calibrated incorrectly. b. Limit switches set incorrectly. c. Over-travel limit switch failure.	a. Calibrate 0% and 100% positions of DCM-3. b. Readjust the limit switches. c. Replace the over-travel limit switch assembly (RET/EXT).
24. Position Feedback signal does not reach maximum signal, but low end calibration is correct.	a. Feedback loop is overloaded.	a. Make sure that the load resistance is between 0 and 800 ohms total across terminals DD and EE.
25. Actuator runs uncontrolled to one end of travel.	a. Handswitch Failure. b. The DCM-3 is malfunctioning. c. The CPS-5 is malfunctioning. d. Terminal block jumpers F to N and D to M not connected. e. The actuator has detected a loss of Demand signal (LOS) and is configured for GTP 0% or 100%. f. Handswitch in RETRACT or EXTEND position.	a. Check continuity from terminals A–V and A–U with Handswitch in AUTO and actuator power disconnected. If either shows continuity, replace Handswitch. b. Verify CPS-5 voltage signal at DCM-3 test points TP4 and TP1 for 1–5 volts DC corresponding with output shaft position. If signal is valid, replace DCM-3. c. Verify CPS-5 wire connections, check voltage at DCM-3 test points TP4 and TP1 for 1–5 volts DC corresponding with output shaft position. Replace CPS-5 if voltage does not change with position. d. Install jumpers. e. See troubleshooting condition no. 3 (Demand LED is illuminated). f. Return Handswitch to AUTO position.

APPENDIX HART[®] Communication

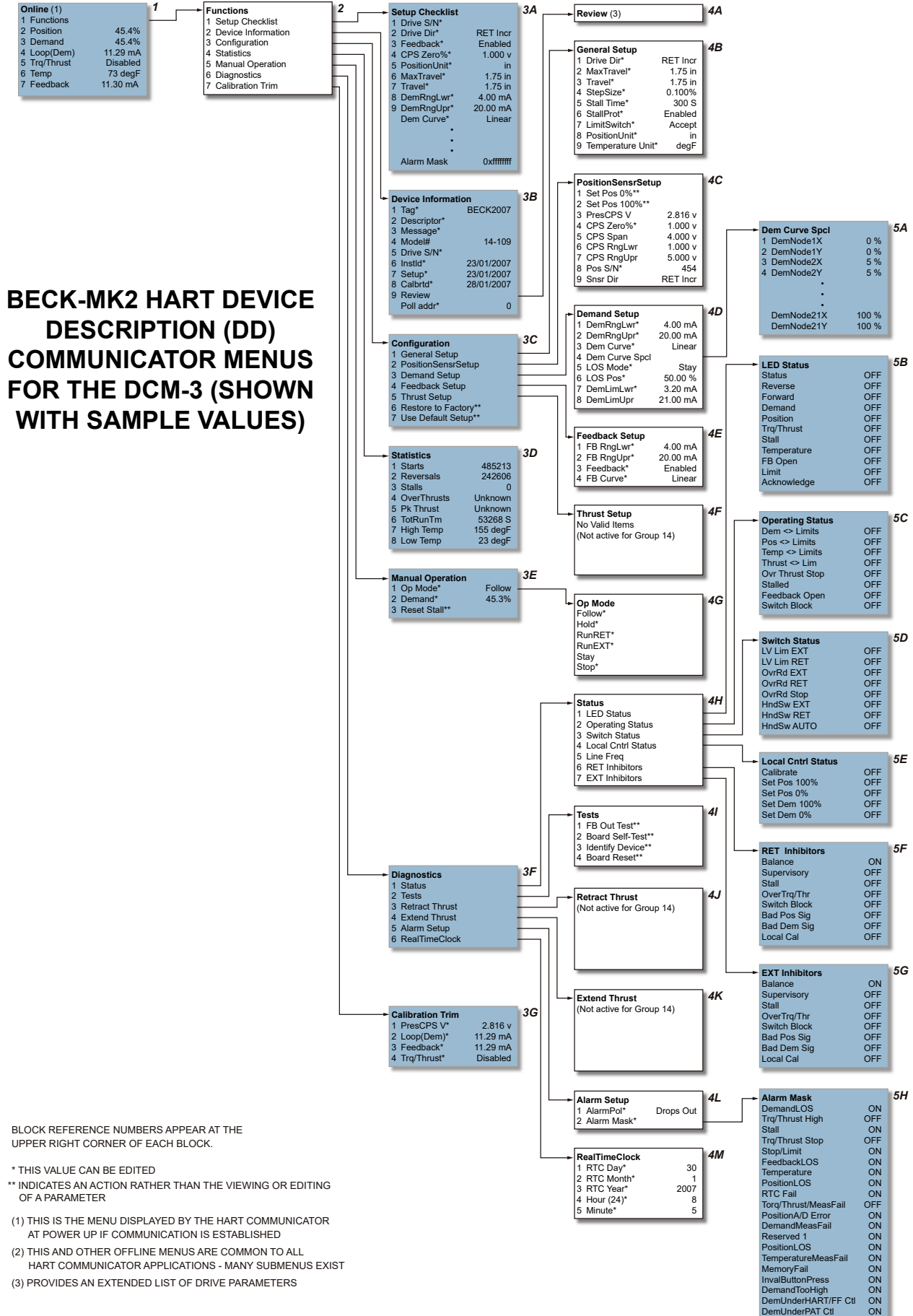

BLOCK REFERENCE NUMBERS APPEAR AT THE UPPER RIGHT CORNER OF EACH BLOCK.

* THIS VALUE CAN BE EDITED

** INDICATES AN ACTION RATHER THAN THE VIEWING OR EDITING OF A PARAMETER

(1) THIS IS THE MENU DISPLAYED BY THE HART COMMUNICATOR AT POWER UP IF COMMUNICATION IS ESTABLISHED

(2) THIS AND OTHER OFFLINE MENUS ARE COMMON TO ALL HART COMMUNICATOR APPLICATIONS - MANY SUBMENUS EXIST

(3) PROVIDES AN EXTENDED LIST OF DRIVE PARAMETERS

APPENDIX HART® Communication

The DCM-3 board is the control center of the actuator—configuration and calibration are accessed and set through the DCM-3 board. Using the HART interface requires a HART compatible communicator or any device, computer or controller capable of communicating with HART devices and supporting the Beck DCM-3 Device Description (DD). This instruction supports actuators built after December 1, 2006, equipped with a DCM-3 (p/n 22-5012-59). This DCM-3 interfaces with the BECK-MK2 DD.

HART® INTERFACE

The interface menu tree for communicating with a DCM-3 using the BECK-MK2 DD is located on the previous page. This menu tree summarizes possible setup options, features and available information.

HART® COMMUNICATORS FOR BECK-MK2

The BECK-MK2 Device Description requires a HART Communicator that is HART 5 capable and has the ability to import Device Description Language Files (DDL) that are certified by the HART Communications Foundation.

USING THE 275, 375 OR 475 HART® COMMUNICATOR

The HART Communicator leads should be connected in parallel with the analog Demand signal wiring. This allows the communicator to simultaneously communicate over the analog input wires. This does not disturb the analog Demand signal, or disrupt the DCM-3 functions. However, any program changes to the DCM-3 will momentarily suspend the operation of the board (maintains last state) while the change is implemented. Typically, this is only for a second or two.

With the communicator connected in parallel anywhere across the analog Demand wires (see illustration below), it is ready to communicate. Turn on the communicator and wait for communications to be established. When communications are established, the “Online” display will appear. If the actuator is multidropped with other devices on a HART network, the first display screen will list all devices and require a selection before the “Online” display is shown. Follow the HART DD menu on the previous page to navigate.

NOTE: If the communicator is unable to communicate with the DCM-3, it displays the message, “No Device Found”. If this occurs, check to make sure the leads are securely connected to the Demand wiring and retry. If communications still do not occur, the communicator polling setup may be improperly set. Check the “utility” menu and make sure communications polling is set to “always poll”.

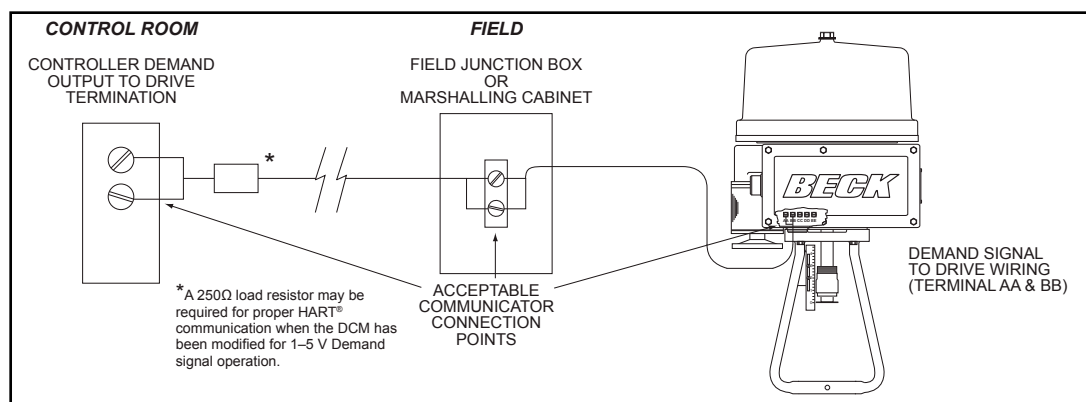

MENU DESCRIPTIONS

(See HART Communicator Menu on page 47)

MENU 1 -- Online

When communications are established with the communicator, the Online menu is displayed.

- 1 Functions:** The link to the menu tree.
- 2 Position:** The output shaft position displayed as a percent of range.

- 3 Demand:** The Demand signal displayed as a percent of range.
- 4 Loop (Dem):** The Demand signal measured in mA.
- 5 Trq/Thrust:** Not active for Group 14 .
- 6 Temp:** The ambient temperature of the DCM-3.
- 7 Feedback:** Milliamp output signal representing the present position of the output shaft.

MENU 2 -- Functions

From the Functions menu, any of the DCM-3 functional menus can be selected and accessed. There are seven functional areas: Setup Checklist, Device Information, Configuration, Statistics, Manual Operation, Diagnostics, and Calibration Trim.

MENU 3A -- Setup Checklist

The Setup Checklist provides a quick way to setup the most important items necessary for basic actuator operation without having to move through multiple sub-menus. These items are defined on the following pages in their specific menu locations.

MENU 3B -- Device Information

The Device Information menu provides information about the actuator. There are ten useful information entries that may be viewed and/or edited.

- 1 Tag:** An 8 character entry that can be used to identify a specific field device label.
- 2 Descriptor:** A 16 character field that can be used to provide any description desired.
- 3 Message:** A 32 character field that can be used to provide any message desired.
- 4 Model#:** Displays the model number of the actuator in which the DCM-3 is installed. This field may be edited. Note that changing this field may cause the "Use Default Setup" command to not function.
- 5 Drive S/N:** The Serial number as shown on the actuator nameplate.
- 6 InstId:** Installation date of the DCM-3.
- 7 Setup:** The setup date has no affect on actuator operation.
- 8 Calbrtd:** The calibration date has no affect on actuator operation.
- 9 Review:** Link to the Review menu.
- 10 Poll addr:** Used to find the actuator. Most configurations should use "0".

MENU 3C -- Configuration

The Configuration menu serves as the gateway to all of the actuator operating parameters that can be used to configure the actuator based on the desired operation.

- 1 General Setup:** Link to General Setup menu.
- 2 PositionSensrSetup:** Link to PositionSensrSetup menu.

- 3 Demand Setup:** Link to Demand Setup menu.
- 4 Feedback Setup:** Link to Feedback Setup menu.
- 5 Torque Setup:** Not active for Group 14.
- 6 Restore to Factory:** Restores field-configurable parameters back to the settings in effect when the DCM-3 was shipped from the factory.
- 7 Use Default Setup:** Changes the DCM-3 position sensing voltage ranges to the proper ranges for the actuator model.

MENU 4B -- General Setup

This menu sets actuator operating parameters. The nine parameter entries are as follows:

- 1 Drive Dir:** The direction the output shaft moves in response to an increasing Demand signal.
- 2 MaxTravel:** The maximum available travel distance of the output shaft in inches. This number corresponds to the actuator design—if the correct Serial Number is entered, this parameter should not be changed.
- 3 Travel:** The number of inches of output shaft travel for 100% span.
- 4 StepSize:** The smallest Demand change that will cause an output shaft movement.
- 5 Stall Time:** The amount of time the motor will run before Stall Protection is initiated.
- 6 StallProt:** This entry is set as either "Enabled" or "Disabled".
- 7 LimitSwitch:** This entry is set as either "Accept" or "Alert" and defines whether or not contacting an overtravel limit switch outside of the normal 0% to 100% travel range will cause an alarm condition.
- 8 PositionUnit:** The numeric unit of measure for the output shaft position (inches).
- 9 Temperature Unit:** The unit of measure for temperature sensing. May be "degF" (fahrenheit) or "degC" (celsius).

MENU 4C -- PositionSensrSetup

This menu contains parameters that determine how the DCM-3 interprets the output shaft position signal from the CPS-5.

- 1 Set Pos 0%:** Sets the 0% position to match the present output shaft position. This does not change the 100% position.

APPENDIX HART® Communication

- 2 Set Pos 100% Span:** Sets the 100% position to match the present output shaft position. Also instructs the DCM-3 to change "Travel" span based on the 0% position. This does not change the 0% position.
- 3 PresCPS V:** Displays the CPS-5 signal voltage at the present output shaft position. Not editable.
- 4 CPS Zero%:** Displays the CPS-5 voltage at the 0% output shaft position. May be edited to define the voltage at the lowest operating point of travel.
- 5 CPS Span:** Displays the voltage signal span from the CPS-5 for maximum possible rotation of the output shaft. This is the upper range voltage minus the lower range voltage. Not editable.
- 6 CPS RngLwr:** Displays the CPS-5 voltage signal at the lowest possible point of travel. Not editable.
- 7 CPS RngUpr:** Displays the CPS-5 voltage signal at the highest possible point of travel. Not editable.
- 8 Pos S/N:** Displays the Serial number of the CPS-5 and has no effect on actuator function.
- 9 Snsr Dir:** The direction of output shaft movement that causes the CPS-5 signal to increase. This direction is typically RET (retract) and is not editable.

MENU 4D -- Demand Setup

The parameters on this menu determine the range and characterization of the Demand signal. It also includes parameters that determine behavior when the Demand signal is absent.

- 1 DemRngLwr:** Sets and displays the signal value in mA that represents 0% Demand (default is 4.00 mA, minimum is 0.5 mA). This value should be set above "DemLimLwr".
- 2 DemRngUpr:** Sets and displays the signal value in mA that represents 100% Demand (default is 20.00 mA, maximum is 21.00 mA). This value should be set below "DemLimUpr".
- 3 Dem Curve:** Determines the relationship between the Demand signal and the position of the output shaft. Typically set to Linear, but may also be set to Square, Square Root or customized Special Curve.
- 4 Dem Curve Spcl:** Link to the "Dem Curve Spcl" menu.
- 5 LOS Mode:** Action on loss of Demand signal.
- 6 LOS Pos:** If the "LOS Mode" has been set to "Go-to-Pos", this defines where the output shaft will move (in percent of travel) during loss of Demand signal conditions.

MENU 5A -- Dem Curve Spcl

This menu allows setting the Demand signal characterization curve.

MENU 4E -- Feedback Setup

This menu is where all the Feedback signal related actuator parameters are set.

- 1 FBRngLwr:** The value of the Feedback signal (in mA) that corresponds to a 0% output shaft position. This value can range between 3.00 mA and 16.00 mA (default = 4.00 mA).
- 2 FBRngUpr:** The value of the Feedback signal (in mA) that corresponds to a 100% output shaft position. This value can range between 7.00 mA and 21.00 mA (default = 20.00 mA).
- 3 Feedback:** Enables or Disables the Feedback signal.
- 4 FB Curve:** Allows a choice between a Feedback signal that linearly represents true shaft position or a characterized Feedback signal that inverts the effect of a characterized Demand signal.

MENU 4F -- Torque Setup (optional)

This menu is inactive for Group 14 actuators.

MENU 3D -- Statistics

This menu is where all the actuator's stored operating statistics are available.

- 1 Starts:** The total number of motor starts.
- 2 Reversals:** The total number of times the motor has started in the direction opposite to the previous start.
- 3 Stalls:** The total number of times the stall time has been exceeded.
- 4 OverTorques:** Not active for Group 14.
- 5 Pk Torque:** Not active for Group 14.
- 6 TotRunTm:** Total amount of time the motor has been powered (in seconds).

7 High Temp: Highest temperature recorded in the DCM-3 compartment (in degrees fahrenheit).

8 Low Temp: Lowest temperature recorded in the DCM-3 compartment (in degrees fahrenheit).

MENU 3E -- Manual Operation

This menu is used to allow manual operation using HART® communications. There are three manual operation procedures available:

1 Op mode (Menu 4G): Selects the operating mode of the DCM-3. There are six possible choices: "Follow", "Hold", "RunRET", "RunEXT", "Stay" and "Stop". "Follow" mode is the normal state of operation and allows the DCM-3 control in response to the analog input Demand signal. "Hold" mode forces the DCM-3 to position according to the HART Demand value (see right). "RunRET" mode forces the actuator to retract. "RunEXT" forces the actuator to extend. The "Stay" mode forces the actuator to maintain its present position. Note that in "Stay" mode, the Handwheel cannot be freely turned. The "Stop" mode removes power from the motor. Note that in "Stop" mode the Handwheel can be freely turned. Note that the Handswitch overrides all operating modes.

2 Demand: This procedure sets the effective Demand signal. If "Op mode" is set to "Hold", entering a valid value (-5% to 105%) will control the motor. If "Op mode" is set to "Follow", the analog Demand signal is displayed (unless an alarm condition exists).

3 Reset Stall: This procedure resets normal actuator operation after a stall condition has caused the motor to shut down. Note that stall conditions can also be reset by simply reversing the input Demand signal or cycling the actuator AC power.

MENU 3F -- Diagnostics

This menu provides access to all DCM-3 stored diagnostic information concerning actuator operation.

MENU 4H -- Status

This menu provides links to menus that monitor the operational status of the actuator. It also displays one parameter, line frequency.

5 Line Freq: The power line frequency as measured by the DCM-3.

MENU 5B -- LED Status

The LED Status parameter allows remote checking of which LED's on the DCM-3 are illuminated.

MENU 5C -- Operating Status

The Operating Status parameter is a summary of whether process-related conditions are inside or outside of anticipated limits. These conditions control the Status Indication LEDs.

1 Demand: Caused by the Demand signal falling below or above acceptable levels.

2 Position: Caused by the CPS-5 signal being outside the range anticipated by the DCM-3.

3 Temperature: The ambient temperature of the DCM-3 is outside of the rating.

4 Torque: Inactive for Group 14.

5 Overtorque Stop: Inactive for Group 14.

6 Stalled: A Stall alarm is active.

7 Feedback Open: The Feedback signal is enabled, but cannot follow the proper current.

8 Switch Block: The DCM-3 cannot power the motor due to an electro-mechanical switch. Check the Handswitch and over-travel limit switches.

MENU 5D -- Switch Status

This menu displays the ON or OFF status of the eight switch parameters: LV Lim EXT, LV Lim RET, OvrRd EXT, OvrRd RET, OvrRd Stop, HndSw EXT, HndSw RET, and HndSw AUTO. The Switch Status menu displays the status of the RET/EXT control override input, the STOP control override or if the Handswitch is in the RET/EXT or AUTO position.

MENU 5E -- Local Cntrl Status

This parameter allows remote monitoring of which buttons on the local configuration interface are being pressed.

MENU 5F -- RET Inhibitors

This menu displays the ON or OFF status of the contributing sources of retract movement inhibitors of motor operation: Balance, Supervisory, Stall, Switch Block, Bad Pos Sig, Bad Dem Sig, Local Cal. See table, next page.

APPENDIX HART[®] Communication

CONDITION	DESCRIPTION
Balance	"ON indicates that the Demand and Position are at balance"
Supervisory	"ON indicates that the DCM is initializing"
Stall	"ON indicates a stall condition"
OverTrq/Thr	"The Torque/Thrust option is not installed"
Switch Block	"ON indicates that the Handswitch, Override, or Limit Switch is inhibiting movement"
Bad Pos Sig	"ON indicates that the Position signal is out of range"
Bad Dem Sig	"ON indicates that the Demand signal is out of range"
Local Cal	"ON indicates that a Local Calibration button is pressed"

MENU 5G -- EXT Inhibitors

This menu displays the ON or OFF status of the contributing sources of extend movement inhibitors of motor operation: Balance, Supervisory, Stall, Switch Block, Bad Pos Sig, Bad Dem Sig, Local Cal. See table above.

MENU 4I -- Tests

This menu provides access to some routines that help determine if the actuator is functioning properly.

- 1 FB Out Test:** Allows manual verification of the Feedback output signal to check operation and accuracy.
- 2 Board Self-Test:** Instructs the DCM-3 to check various power and sensing circuits. This test will cause the actuator to reposition, so it should be run offline and only when a DCM-3 problem is suspected.
- 3 Identify Device:** Causes the ACKNOWLEDGE LED on the DCM-3 to flash for two seconds. Ensures the HART system is addressing the correct actuator.
- 4 Board Reset:** Causes the DCM-3 to initiate a reset cycle similar to a power-up reset. This manual reset will cause the actuator to reposition. This procedure is not typically necessary.

MENU 4J -- RET Torque

This menu is inactive for Group 14 actuators.

MENU 4K -- EXT Torque

This menu is inactive for Group 14 actuators.

MENU 4L -- Alarm Setup

The Alarm Setup menu parameters allow modification of the behavior of the alarm.

- 1 AlarmPol:** Whether the solid state relay opens on alarm or closes on alarm.
- 2 Alarm Mask:** Link to the Alarm Mask menu which allows specific alarm conditions to be ignored.

MENU 5H -- Alarm Mask

Allows selection of alarm conditions that will not cause an alarm at terminal E.

MENU 4M -- RealTimeClock

This menu allows the date and time to be set.

- 1 RTC Day:** Day of the month (numeric value).
- 2 RTC Month:** Month (numeric value).
- 3 RTC Year:** Year (4 digits).
- 4 Hour (24):** Hour of the day (24 hour format).
- 5 Minute:** Minute of the hour (0 through 59).

MENU 3G -- Calibration Trim

The Calibration Trim menu sets and displays actuator calibration values. **Note that changing the calibration trim can cause signal measurement difficulties if performed improperly.**

- 1 PresCPS V:** Displays and/or trims the present voltage of the position signal. This value may also be measured at DCM-3 test points TP1(-) and TP4(+). This trim is set and tested at the factory. Changing this value can cause voltage measurement errors.
- 2 Loop(Dem):** Displays the Demand signal as measured at the field wiring terminals. When the Demand control loop signal is being overridden by a special mode of operation, the effective Demand will not correspond to the mA value. This value can be edited to trim the Demand to ensure accurate measurement of the analog signal. Demand can only be trimmed at 4.0 mA and 20.0 mA.
- 3 Feedback:** Displays the mA signal representing the output shaft position as measured at the field wiring terminals. This value can be edited.
- 4 Trq/Thrust:** Not active for Group14.

APPENDIX HART® Messages

COMMON HART® MESSAGES

HART® protocol maintains both standard and device specific informational messages that are displayed on the Communicator when various conditions occur.

Below is a table of typical Beck messages and message sequences. It does not include all possible messages, only the most common.

Output Shaft Position Measurement Messages

Message	Description
"Process applied to the primary variable is outside the operating limits of the field device."	This is a standard HART-defined message that appears whenever the HART primary variable (Position signal) is outside the design or calibrated range. This message should be accompanied by a Beck-specific message with more detail.
"The Position Signal is less than -5% or greater than 105%."	This Beck-specific message indicates the DCM-3 is reading a Position signal not within the calibration range limits.
"Position signal in LOS."	This is a Beck-specific message. The DCM-3 is indicating that the Position signal is a problem and is intended to identify a CPS-5 or wiring failure. This is triggered when the Position signal is outside the minimum and maximum voltage limits.
"Position out of accurate measurement range."	This is a Beck-specific message. The DCM-3 indicates the Position signal is outside of the design range.
"Position sensing error."	This is a Beck-specific message. The DCM-3 circuitry for measuring the Position signal does not appear to be functioning properly.
"Analog output 1 and its digital representation are outside the operating range limits, and not responding to input."	This is a standard HART-defined message that appears whenever the position signal to the DCM-3 is outside the design or calibrated range. This message should be accompanied by a Beck-specific message with more detail.

Handswitch and Over-travel Limit Switch Message

Message	Description
"Motor power is blocked, check switches."	This message will appear if the DCM-3 detects a condition that prevents current flow to the motor.

Stall Protection Message

Message	Description
"Stall condition has been detected (see 'Stall Time' in the 'General Setup' menu)."	This is a Beck-specific message indicating that the actuator is in a stalled condition. This occurs if the actuator cannot reach the Demand position in the time allotted by the stall time setting (configurable from 30–300 seconds).

APPENDIX HART® Messages

Demand and Temperature Measurement Messages

Message	Description
"Process applied to the non-primary variable is outside the operating limits of the field device."	This is a standard HART-defined message that appears whenever the Demand signal or Temperature are outside their design or calibrated ranges. This message should be accompanied by a Beck-specific message with more detail.
"The Demand Signal is outside of the intended limits (see Demand Setup menu)."	This Beck-specific message indicates the Demand signal is invalid.
"Demand out of accurate measurement range."	This is a Beck-specific message that the Demand signal is not only out of the calibrated range, but also out of the design range of the actuator. The lower and upper limits are 0.1 V dc and 5.5 V dc, respectively. Note that current input DCM-3 boards utilize a 250 Ohm input resistor to convert the current signal to voltage.
Demand Signal is out of limit.	This Beck-specific message indicates the Demand signal is too high to measure accurately. The upper limit is 5.5 V dc. Note that current input DCM-3 boards utilize a 250 Ohm input resistor to convert the current signal to voltage.
Demand sensing error.	This is a Beck-specific message. The Demand sensing circuitry does not appear to be functioning properly.
The temperature is outside of -40°F to 185°F.	This is a Beck-specific message indicating that the temperature at the DCM-3 is outside of the acceptable range.
Temperature out of accurate measurement range.	This is a Beck-specific message. The DCM-3 ambient temperature reading is extreme and cannot be accurately measured.
Temperature A/D Fail.	This is a Beck-specific message. The DCM-3 circuitry for measuring the ambient temperature does not appear to be functioning properly.
The Feedback Signal is enabled but the loop is open.	This is a Beck-specific message indicating that the Feedback sourcing circuit is unable to create the proper signal current. This message could result from the signal not being wired to an external load, or a wiring failure has occurred at some point between the actuator and the monitoring device.

Questionable Configuration Messages

Message	Description
Analog output 1 and its digital representation are in fixed mode, and not responsive to input changes.	Standard HART-defined message that appears whenever the Feedback signal has been manually assigned a value. This message should be accompanied by a Beck specific message with more detail.
Feedback is in fixed mode.	A Beck-specific message indicating that the Feedback signal has been manually set to a fixed value and is not following the Position value.
Local control button pressed while locked-out.	A Beck-specific message indicating an incorrect combination of pushbuttons is being pressed on the local configuration interface, or the local control interface is disabled and a pushbutton is being pressed.
Loop Current Detected while under HART/FF Control.	A Beck specific alarm message that alerts the user that analog current is present on the Demand terminals, but the DCM-3 is in an Op Mode expecting digital control. Make certain the Op Mode parameter is set properly.
Loop Current Detected while set for LOS PAT.	A Beck specific alarm message that alerts the user that analog current is present on the Demand terminals, but the DCM-3 is set to a LOS mode intended to be used without an analog signal.

DCM-3 Failure Messages

Message	Description
Real-time Clock hardware failure.	This is a Beck-specific message. The data in the Real-time Clock appears invalid.
FRAM Memory has failed.	A Beck-specific message. The continuous built-in self-test cannot verify the memory for statistics information is operating properly.
Memory failure.	This is a Beck-specific message. The continuous built-in self-test cannot verify the microcomputer is operating properly.

Miscellaneous HART-Defined Messages

Message	Description
Field device has more status available.	This is a standard HART-defined message that appears whenever the DCM-3 signals the HART master that an alarm or other undesirable status exists. This is the HART protocol mechanism for displaying the other messages in this section. If this message is displayed without an additional message, the status cleared before the HART master read the additional status.
A reset or self-test of the field device has occurred, or power has been removed and reapplied.	This message is presented by the HART master if the DCM-3 has gone through a power-up reset sequence since the last communication with the master. This message is only displayed once after a reset.
A modification has been made to the configuration of the field device.	This message indicates that the DCM-3 has undergone a configuration change since the last time the HART master has reset the change flag. Many HART masters disregard the flag and do not report this message.
Field device has malfunctioned due to a hardware error or failure.	This message indicates that the continuous built-in self-test cannot verify the microcomputer is operating properly.

APPENDIX Serial Communication

COMMUNICATIONS

Local configuration of the Beck actuator can be accomplished using Serial commands through the DCM-3 Serial port.



CAUTION

Changes made to the actuator through Serial communications may not necessarily be reflected in asset management systems. Be sure to verify any changes made serially and make manual corrections to the asset management system if necessary.

The Beck Digital Control Module (DCM-3) is equipped with a Serial interface which allows for direct communication with a computer. Using a standard DB9 to USB cable, connect the DCM-3 to the computer using the DCM-3's DB9 connector (see below for location) and one of the computer's USB ports. Note: If your computer is equipped with an active COM port, a DB9 to DB9 cable may be utilized. See below for part numbers of cables available from Beck.

Once connected, communication can be established between the DCM-3 and the computer using a terminal emulation program, such as HyperTerminal®. This method of communication will allow for configuration, calibration and verification of actuator DCM-3 settings without the use of custom software applications.



DB9
Connector

HyperTerminal® SOFTWARE

HyperTerminal is the standard ASCII terminal emulation software provided with Microsoft® Windows®. If using HyperTerminal®, the following instructions will assist in setup. Note that some variation to these instructions may be necessary depending on the version of HyperTerminal® being used.

After connecting the DCM-3 to the (Windows®-based) computer, access HyperTerminal® by clicking first on "Start", then "Programs", then "Accessories", then "Communications", then "HyperTerminal". Double-click on the "Hypertrm.exe" icon to start the program. Once HyperTerminal® is running, it is necessary to set up a file with the proper settings to communicate with the DCM-3. Proceed as follows:

1. If prompted to install a modem, answer "no". Proceed to enter a name (e.g., "DCM-3") and select an icon (any will suffice) in the "Connection Description" box. Click the "OK" button.
2. The "Connect to" box should open next. At the bottom of the box, set the "Connect using" selection to the appropriate USB (or COM) port that has been connected to the DCM-3. Click the "OK" button.
3. The port properties box should open next; this is where the communication settings are established. The correct settings are:
 - a. Bits per second = "1200"
 - b. Data bits = "8"
 - c. Parity = "none"
 - d. Stop bits = "1"
 - e. Flow control = "none"
4. With the appropriate settings entered from Step 3, above, click "OK". Communications should now be enabled.
5. Press the "Enter" key twice. "OK" should be displayed indicating that HyperTerminal® is communicating with the DCM-3.

Beck Serial Communications Cables



DB9 to USB-A
P/N 20-0511-60



DB9 to DB9
P/N 20-0511-14

*Note cables may differ in appearance from depiction.

APPENDIX Serial Commands

COMMANDS AND ARGUMENTS

Commands can be used for a variety of functions including changing the operating configuration of the actuator, verifying operation settings, calibration and accessing diagnostic information. There are essentially four different types of commands:

1. Dual-purpose commands. These commands can be used to either modify actuator configuration settings or display the settings already set in the actuator. In order to set or make a change to the settings, the command requires an argument (*n*). If the command is used for display purposes only, the argument is omitted. Examples of these commands include "temperature" and "demlos".
2. Display only commands. These commands are used to display diagnostic or operating information such as present signal values. No arguments are required. Examples include the "stat" command and the "signals" command.
3. Set only commands. These commands serve only to make a parameter change. Typically, they apply to the actuator calibration. This type of command requires an argument, but unlike dual-purpose commands, they return an error message when entered without an argument. Examples include the "charset" and "trimfdbk4mA" command.
4. Execute action commands. These commands serve to reset, enable or disable features. Entering these commands produces an immediate action. Examples include the "reset" and "restoremodes" command.

The available commands are listed on the next several pages and each is described in detail. The command description explains the use or uses of the command, while the argument column describes any applicable arguments. Arguments are denoted as *n*. Note that the commands described as "sets and/or displays" signify dual-purpose commands that can be used with or without an argument for setting or verifying configuration settings.

APPENDIX Serial Commands

SERIAL COMMANDS

The following is a categorized list of Serial commands available through the DB9 interface. These commands are described in detail on the pages that follow. Error codes are shown on page 67.

Output Shaft Position Sensing Commands

cpsvat0pct	travel
------------	--------

General Configuration Commands

alarmout	restoremodes
alarmoutmask	sernum
configformodel	stallprot
drvdir	stalltime
limitalarm	stepsize
opmode	

HART® Configuration Commands

polladdr

Diagnostic and Information Commands

demsources	signals
help	stat
ledtest	temperature
reset	unstall

Demand Signal Commands

dem0pctma	demlogstp delay
dem100pctma	trimdem4ma
demlos	trimdem20ma
demlogstp	

Demand Characterizer Commands

charclear	charset
charlist	demfunc

Feedback Signal Commands

fdbk0pctma	trimfdbk4ma
fdbk100pctma	trimfdbk20ma
fdbkfunc	iomode

Output Shaft Position Sensing Commands

Command	Description	Argument <i>n</i> and Information
cpsvat0pct <i>n</i>	Sets/displays the DCM-3 voltage setting used to determine 0% signal from the CPS-5. Typically, this setting does not need to be changed.	<i>n</i> = desired voltage as a decimal (carried out to 3 decimal places). The standard signal range for full output shaft travel is approx. 1.000–5.000 V.
travel <i>n</i>	Sets/displays the value that represents 100% travel.	<i>n</i> = desired length of travel in inches. This value cannot exceed the maximum travel range of the actuator (see page 23 for details).

General Configuration Commands

Command	Description	Argument <i>n</i> and Information
alarmout <i>n</i>	Sets/displays the polarity of the alarm output solid state relay.	<i>n</i> = "0": open on Alarm <i>n</i> = "1": closed on Alarm Upon loss of power, the relay is open regardless of the setting.
alarmoutmask <i>n</i>	Sets/displays (in hexadecimal format) which conditions will cause an alarm: 0x00000001 - Demand Loss of Signal 0x00000004 - Stall Condition 0x00000010 - Stop/Limit 0x00000020 - Feedback Loss of Signal 0x00000040 - Temperature too High/Low 0x00000080 - Position Outside of Limits 0x00000100 - Real-time Clock Failure 0x00000400 - Position Analog/Digital Circuit Failure 0x00000800 - Demand Measurement Failure 0x00002000 - Position Loss of Signal 0x00004000 - Temperature Measurement Failure 0x00008000 - Memory Failure 0x00010000 - Invalid Button Pressed 0x00020000 - Demand too High	<i>n</i> = "0x0": no listed condition causes a status alarm <i>n</i> = "0xffffffff": all listed conditions cause a status alarm <i>n</i> = hexadecimal value for specific condition(s) which will cause an alarm. Multiple conditions may be selected by performing a hexadecimal addition of the condition values; e.g., Stall Condition and Torque Stop alarms -- hex 0x04 + 0x08 = 0x0C.
configformodel <i>n</i>	Sets certain DCM-3 default values based on the actuator Serial number. These values are direction travel for an increasing CPS-5 signal, expected range of CPS-5 signal, and the maximum travel.	<i>n</i> = "1": executes command
drvdir <i>n</i>	Sets/displays the actuator output shaft direction resulting from an increasing Demand signal.	<i>n</i> = "0": Retract <i>n</i> = "1": Extend
limitalarm <i>n</i>	Sets/displays alarm action if the actuator travels outside of the electronic limits and contacts an over-travel limit switch.	<i>n</i> = "0": mute (no alarm) <i>n</i> = "1": always
opmode <i>n</i>	Sets/displays the mode that controls the Demand signal source. This mode selects analog or digital control.	<i>n</i> = "0": analog Demand <i>n</i> = "1": digital Demand <i>n</i> = "2": retract <i>n</i> = "3": extend <i>n</i> = "4": stay <i>n</i> = "5": stop
restoremodes <i>n</i>	Returns the DCM-3 settings to the original factory configuration.	<i>n</i> = "1": executes command
sernum <i>n</i>	Sets the actuator Serial number.	<i>n</i> = Serial number
stallprot <i>n</i>	Sets/displays stall protection state.	<i>n</i> = "0": disabled <i>n</i> = "1": enabled
stalltime <i>n</i>	Sets/displays time the actuator runs in one direction before stall alarm is activated.	<i>n</i> = seconds: acceptable range is 30–450 seconds.
stepsize <i>n</i> %	Sets/displays the size of one incremental movement of the output shaft.	<i>n</i> = % of travel desired: acceptable range is 0.10%–2.5%. Include the "%" symbol after the number, otherwise the unit of measure will be inches.

APPENDIX Serial Commands

HART® Configuration Commands

Command	Description	Argument <i>n</i> and Information
polladdr <i>n</i>	Sets/displays the polling address used by the HART master to find individual devices if the HART bus has more than one device.	<i>n</i> = the polling address (a number between "0" and "15"). Unless multiple HART devices are connected in parallel on a single bus, the polling address should be set to "0".

Diagnostic and Information Commands

Command	Description	Argument <i>n</i> and Information
demsources	Provides information regarding Demand including; the source of Demand signal (Handswitch, demlos or Analog I/P), mode (follow, hold, RET, EXT, Stay or Stop), currently applied Demand signal as a %, the Demand function (linear, square root, square, or special), and the Demand out as a % (dem out shows the signal adjusted when using a non-linear Demand function (demfunc command)).	No Argument
help <i>n</i>	Displays help text for a specific command or lists all available Serial commands.	<i>n</i> = command name <i>n</i> = "all"
ledtest <i>n</i>	Tests the functionality of the DCM-3 LEDs individually or as a group. If "all" is selected, the command will consecutively cycle through each LED twice. If an individual LED is selected, it will flash 12 times.	<i>n</i> = "1": DEMAND <i>n</i> = "2": POSITION <i>n</i> = "4": STALL <i>n</i> = "5": TEMP °F <i>n</i> = "6": FB OPEN <i>n</i> = "7": STOP/LIMIT <i>n</i> = "8": ACKNOWLEDGE <i>n</i> = "100": FWD <i>n</i> = "101": REV <i>n</i> = "102": STAT <i>n</i> = "All"
reset <i>n</i>	Performs the same reset sequence as when power is removed and reapplied.	<i>n</i> = "1": must equal "1" for command to execute.
signals	Displays the present DCM-3 readings of 3 signals: Position signal from CPS-5 Demand Feedback	No argument = signal readings are displayed. <i>n</i> = "all": an extended set of data is displayed.
stat	Displays information on the status of the actuator, including: Time / Date, Demand, Position, Error (Demand minus Position), Step size, Dead band Motor Status, Motor Run Time, Line Frequency, Motor Starts, Motor Reversals/Stalls, RET and EXT Inhibitor Status, Alarms	No argument
temperature <i>n</i>	Displays three values describing the ambient temperature in the actuator. Low extreme, present, high extreme. Can also change the temperature units.	No argument = temperatures are displayed. <i>n</i> = "F": changes units to Fahrenheit <i>n</i> = "C": changes units to Celsius
unstall	Resets the Stall Protection alarm to restore power to the motor. If the motor is still physically stalled, the Stall Protection alarm will recur.	No argument.

Demand Signal Commands

Command	Description	Argument <i>n</i> and Information
dem0pctma <i>n</i>	Sets/displays the Demand signal value that corresponds to 0% actuator position.	<i>n</i> = Demand signal as a decimal in mA. Minimum value is 0.50; maximum value is 100% Demand less 4.00 mA (e.g., if 100% Demand is 20.00 mA, the 0% value must be set for 16.00 mA or less).
dem100pctma <i>n</i>	Sets/displays the Demand signal value that corresponds to 100% actuator position.	<i>n</i> = Demand signal as a decimal in mA. Minimum value is 0% Demand plus 4.00 mA (e.g., if 0% Demand is 4.00 mA, the 100% value must be set for 8.00 mA or greater). Maximum value is 21.00 mA.
demlos <i>n</i>	Sets/displays the Demand signal threshold, below which the DCM-3 recognizes the signal has been lost. The threshold is entered as a value in mA. This command also sets/displays the action initiated by the actuator during LOS (Loss Of Signal). LOS action options are "sip" (stay in place) or "gtp" (go to position). Demlos always reports both settings, but only sets one argument at a time. Demlos must be used twice to set both the threshold and action.	<i>n</i> = Demand signal in mA below which LOS occurs (e.g., the typical value for a 4–20 mA system is 3.20). -OR- <i>n</i> = "sip", "gtp" or "pat". The "pat" argument acts the same as "sip", but also suppresses the alarm--this is used in some pulsed applications.
demlosgtp <i>n</i>	Sets/displays the position to which the actuator will run upon loss of the Demand signal (LOS). This command has no effect if the actuator is set to "sip" (stay in place).	<i>n</i> = desired position of actuator expressed as a percentage of actuator travel in decimal form (e.g., 50% = 50.00).
demlosgtp delay <i>n</i>	Sets the time delay in seconds before the actuator will move to the position set in "demlosgtp". Entering this command without an argument will return the present gtp and delay settings.	<i>n</i> = time delay in seconds. Acceptable values are 0 (default) to 25.5.
trimdem4ma 4	Trims the Demand analog-to-digital sensing circuit to be accurate at 4 mA. This command should only be used when the Demand signal at the actuator is exactly 4.0 mA. Trim is factory set and should not normally require recalibration.	"4" is the only acceptable value; this trim can only be performed at 4 mA.
trimdem20ma 20	Trims the Demand analog-to-digital sensing circuit to be accurate at 20 mA. This command should only be used when the Demand signal at the actuator is exactly 20.0 mA. Trim is factory set and should not normally require recalibration.	"20" is the only acceptable value; this trim can only be performed at 20 mA.

APPENDIX Serial Commands

Demand Characterizer Commands

Command	Description	Argument <i>n</i> and Information
charclear <i>n</i>	Clears a preconfigured Demand characterizer curve node by setting it to "unused". Any node numerically higher will be set to "unused" also.	<i>n</i> = node number: between 1 and 21.
charlist <i>n</i>	Displays the X-values and Y-values of Demand characterizer curve node(s).	<i>n</i> = node number: between 1 and 21. <i>n</i> = "all": displays all nodes
charset <i>n1, n2, n3</i>	Sets the X-values and Y-values of a specific node of the characterizer curve. The three arguments must be separated by commas.	<i>n1, n2, n3</i> = (<i>n1</i> is node number to modify, <i>n2</i> is X-value as a percentage, <i>n3</i> is Y-value as a percentage)
demfunc <i>n</i>	Sets/displays the Demand signal characterization function.	<i>n</i> = "0": linear <i>n</i> = "1": square root <i>n</i> = "4": special curve <i>n</i> = "5": square

Feedback Signal Commands

Command	Description	Argument <i>n</i> and Information
fdbk0pctma <i>n</i>	Sets/displays the mA value of the Feedback signal that represents the 0% output shaft position.	<i>n</i> = desired Feedback signal in mA at 0% output shaft position. Minimum value is 3.00 mA and the maximum must be at least 4.00 mA less than the Feedback signal value for the 100% output shaft position.
fdbk100pctma <i>n</i>	Sets/displays the mA value of the Feedback signal that represents the 100% output shaft position.	<i>n</i> = desired Feedback signal in mA at 100% output shaft position. Minimum value must be at least 4.00 mA greater than the Feedback signal value for the 0% output shaft position. Maximum value is 21.00 mA.
fdbkfunc <i>n</i>	Sets/displays the curve used to calculate the Feedback signal.	<i>n</i> = "0": linear <i>n</i> = "1": inverse Demand (curve enabled)
trimfdbk4mA <i>n</i>	Trims the Feedback signal at 4 mA. Calibrated at the factory, should not normally require calibration.	<i>n</i> = present Feedback signal from the DCM-3 in mA.
trimfdbk20mA <i>n</i>	Trims the Feedback signal at 20 mA. Calibrated at the factory, should not normally require calibration.	<i>n</i> = present Feedback signal from the DCM-3 in mA.
iomode <i>n</i>	Sets/displays the function of a DCM-3 connector pin. May be enabled for Feedback or potentiometer.	<i>n</i> = "0": none <i>n</i> = "1": Feedback enabled <i>n</i> = "2": potentiometer power enabled.

Command Error Codes

Code	Description	Information
2	Invalid selection	Displayed when an unknown command has been entered.
3	Value too big	Displayed when an entered numeric value exceeds expected parameters.
4	Value too small	Displayed when an entered numeric value is less than expected parameters.
5	Data length error	Displayed when the wrong number of arguments is entered.
6	General error	Displayed when a combination of circumstances prevents a better description of the error.
9	Process too high	Displayed when the entered value exceeds acceptable parameters when calibrating a 0% value.
10	Process too low	Displayed when the entered value is less than acceptable parameters when calibrating a 100% value.
14	Span too small	Displayed when entered values for a 0% point and a 100% point are too close.
32	Busy	Displayed when a memory store is requested and another memory store is already in process.
64	Not implemented	Displayed when an entered command is defined, but cannot be implemented.

APPENDIX *Optional DCM-3 w/ Feedback Display*

The DCM-3 Feedback display is an illuminated, numerical readout showing the actuator's position as a percentage of full travel. This display is viewed through a tempered glass window in the electronics compartment. There are also two configurable LEDs visible—a red LED and a green LED.

The DCM-3 display has been calibrated at the factory and should not require any further adjustments.

The display is powered from the Feedback loop current and will not operate until the loop is closed. The Feedback output maximum loop resistance is 500Ω.

The configuration for the Feedback display is 4 mA = 00.0(%) and 20 mA = 100.0(%). By default, the green LED will light when the Feedback is indicated at less than 1(%). The red LED will light when the Feedback is indicated at greater than 99(%).

The illumination points for the LEDs may be modified using a serial command (see next page).

For information on serial communication and commands, see page 56.

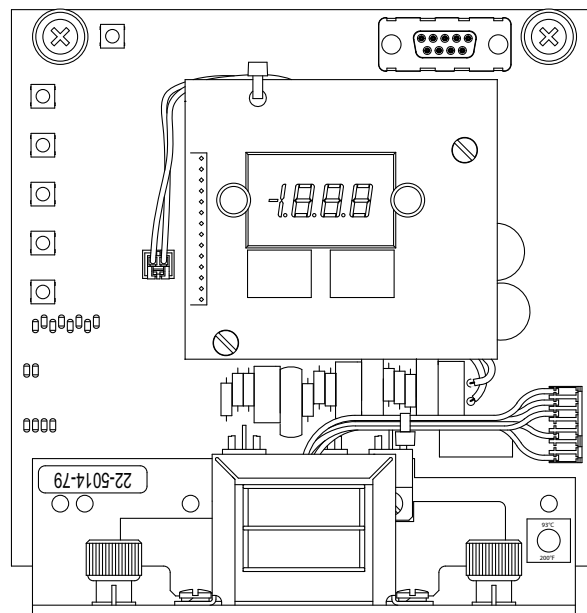

DCM-3 with Feedback Display
Part No. 22-5014-79



ledconfig <i>n1 n2</i>	Changes the point within the position of travel that causes the LEDs to light. May also be used to swap the LED end point assignments (see Example 2, below) or to individually turn off each LED.	<p><i>n1</i> = "red": sets the red LED to the <i>n2</i> argument.</p> <p>"green": sets the green LED to the <i>n2</i> argument.</p> <p>"inverted": swaps the LED end point assignments (see Example 2, below).</p> <p>"noninverted": sets both LED end points to the default setting (see below).</p> <p><i>n2</i> = argument defining position of travel at which the selected LED (<i>n1</i>) will light. Accepts any number representing a valid percentage of travel position.</p> <p>"off": turns off the LED defined in <i>n1</i>.</p>
-------------------------------	--	--

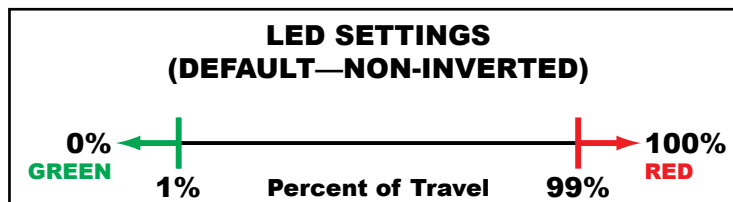

<i>Example 1: Make the "CLOSED" green LED light at 2.0% and the "OPEN" red LED light at 98.0%.</i>	
COMMAND	RESULTING LED BEHAVIOR
ledconfig green 2 ledconfig red 98	<p style="text-align: center;">0% ← GREEN 2% Percent of Travel 98% 100% RED</p>
<i>Example 2: Invert the LED assignments from the default configuration.</i>	
COMMAND	RESULTING LED BEHAVIOR
ledconfig inverted	<p style="text-align: center;">0% ← RED 1% Percent of Travel 99% 100% GREEN</p>
<i>Example 3: Make the "OPEN" red LED light at 1.0% and greater, and the "CLOSED" green LED light at less than 1.0%.</i>	
COMMAND	RESULTING LED BEHAVIOR
ledconfig green 1 ledconfig red 1	<p style="text-align: center;">0% ← GREEN 1% Percent of Travel 99% 100% RED</p>

NOTE: Both LEDs will not light at the same time; in the event of overlap, the red LED will light.

INDEX

Appendices	47–65	Maintenance	34–41
HART® Communication	47–52	Bearings	35
HART® Messages	53–55	CPS-5	38
Serial Communication	56	DCM-3 Board	37
Serial Commands	57–63	Gaskets	35
Optional DCM-3 w/ Feedback Display... ..	64–65	Gears	39
Applications Reviews.....	67	Handswitch	37
Auxiliary Limit Switches	20	Lubrication	35
Components	12–17, 40–41	Motor Assembly	34, 39
Electronic.....	14–17	Motor Capacitor & Resistor Network	34, 39
Mechanical	12–13	Over-travel Limit & Auxiliary Switches	36
Configuration/Calibration	18–33	Seals.....	35
Contactless Position Sensor (CPS-5).....	14, 38	SLM	36
Demand Calibration	25	Outline Dimension Drawings	5
Demand Characterization Curves	28–29	Position Calibration.....	24
Digital Control Module (DCM-3)	14–17, 37	Position Feedback Signal	30–31
Interfaces.....	15	Power Quality	9
Maintenance	37	Precautionary Information	6
Overview LEDs.....	16	Product Demonstrations	67
Pushbutton Controls	17	Restore Factory Settings	23
Status Indication LEDs	17	Safety Precautions	6
Direction of Output Shaft Travel	22	Self-Locking Mechanism (SLM).....	12, 36
General Specifications.....	3–4	Serial Commands	57–63
Handswitch	13, 37	Serial Communication	56
Handwheel.....	13	Services.....	67
HART® Communication.....	47–52	Site Surveys	67
HART® Device Description Menu.....	47	Spare Parts, Recommended	39
HART® Messages	53–55	Specification Writing	67
How to Obtain Service	67	Stall Protection	33
Installation	8–10	Start-up.....	11
Electrical	9	Step Size	23
Mechanical	8	Storage Information.....	6
Wiring	10	Table of Contents.....	2
Introduction.....	2	Temperature Sensing	32
Limit Switches (Over-travel)	19	Travel (Stroke Range)	21
Loss of Demand Signal (LOS).....	26	Change Travel	22
		Troubleshooting	42–46
		Warranty Statement.....	67

SERVICES

PRODUCT DEMONSTRATIONS

Each of Beck's Sales Engineers has access to a complete set of actuator models so that he can demonstrate virtually any of their features at your location. In order to arrange to see a Beck actuator in your plant or office, contact Beck's Sales Department.

SITE SURVEYS

Beck Sales Engineers are available to discuss your process control requirements. Often a visit to your location is the best way to gain a thorough understanding of your needs, in order to meet them most accurately and completely.

Mounting hardware, torque requirements, linkage, control signal information, and optional equipment can be analyzed most effectively at the work site. Beck's analysis at the job site can help ensure that specifications are accurate, especially in the case of complex applications.

APPLICATION REVIEWS

By sharing your needs with a Beck Sales Engineer you can take advantage of the best application advice for the type of control you

need. This review will yield a better understanding of the versatility of Beck actuators for your installations, as well as complete details on options and accessories to make the process as effective as possible.

SPECIFICATION WRITING

Beck provides specification writing assistance in order to help you specify and order the right actuators for your applications. Beck Sales Engineers will work with you to make it easier for you to obtain the proper equipment and give you confidence that no details are overlooked.

HOW TO OBTAIN SERVICE

Factory repair of actuators or subassemblies is available for both normal and emergency service. To assure prompt processing, contact the factory to receive a Returned Material Authorization (RMA) number. If a repair estimation is desired, please send the name and phone number of your contact for service authorization. It is helpful to include a description of the work desired with the shipment or, in the event of a problem, the malfunction being experienced.

THREE YEAR LIMITED EQUIPMENT WARRANTY

Beck warrants to Buyer that: (i) for a period of 3 years from the date of shipment, the Equipment manufactured by Beck shall materially conform to Beck's published standard specifications in effect as of the date of shipment; and (ii) the Beck Equipment will be free from defects in materials and workmanship. This warranty does not apply to normal wear and tear, or where Beck Equipment failure is a result of improper installation, improper storage, misuse or improper maintenance, or water ingress related to Buyer or its agents failing to apply the stated torque requirements to fasteners when attaching covers or failing to replace temporary conduit plugs as stated in the installation instructions, or entry through conduits.

During the Limited Warranty Period, Buyer shall notify Beck of any alleged warranty claim within 30 days from the date Buyer discovers, or upon reasonable inspection should have discovered, such alleged claim (but in any event prior to the end of the Limited Warranty Period), and Buyer shall return the Beck Equipment in question, at Buyer's expense, to Beck for evaluation, in compliance with the terms stated in the "Return of Equipment" article in the Sales Contract. If Beck determines that the Beck Equipment fails to conform to the limited warranty, then, at Beck's sole discretion and its expense (subject to Buyer's conformity with the warranty), Beck will either: (i) repair or replace the Beck Equipment, without charge, at Beck's factory, or (ii) refund the purchase price of such Beck Equipment, less any applicable discounts, rebates, or credits. In no event will Beck's liability exceed the contract price actually paid for such Beck Equipment subject to a warranty claim. Beck makes no warranty, express or implied, with respect to any Buyout Item. This limited warranty is not transferable or assignable to any transferees of the Beck Equipment.

THIS WARRANTY IS EXPRESSLY IN LIEU OF ANY OTHER EXPRESS OR IMPLIED WARRANTY, INCLUDING IMPLIED WARRANTIES OF MERCHANTABILITY AND FITNESS FOR A PARTICULAR PURPOSE, AND ALL OTHER OBLIGATIONS OR LIABILITIES OF BECK. BUYER ACKNOWLEDGES THAT: (i) BECK HAS MADE NO INDEPENDENT INVESTIGATION OF THE SUITABILITY OF THE EQUIPMENT FOR BUYER'S INTENDED USE OR EXISTING SYSTEMS; AND (ii) BUYER HAS NOT RELIED UPON ANY REPRESENTATION OR WARRANTY MADE BY BECK OR ANY OTHER PERSON ON BECK'S BEHALF, EXCEPT AS SPECIFICALLY PROVIDED IN THE SALES CONTRACT. THIS SECTION SETS FORTH BUYER'S SOLE AND EXCLUSIVE REMEDY FOR ANY BREACH OF THE LIMITED WARRANTY SET FORTH IN THIS SECTION.

A 100% EMPLOYEE OWNED COMPANY

BECK

~ founded 1936 ~

SINCE 2021



HAROLD BECK & SONS, INC.

11 TERRY DRIVE • NEWTOWN, PENNSYLVANIA 18940 • USA

PHONE: 215-968-4600 • FAX: 215-860-6383 • E-MAIL: sales@haroldbeck.com

www.haroldbeck.com

Made in USA

