

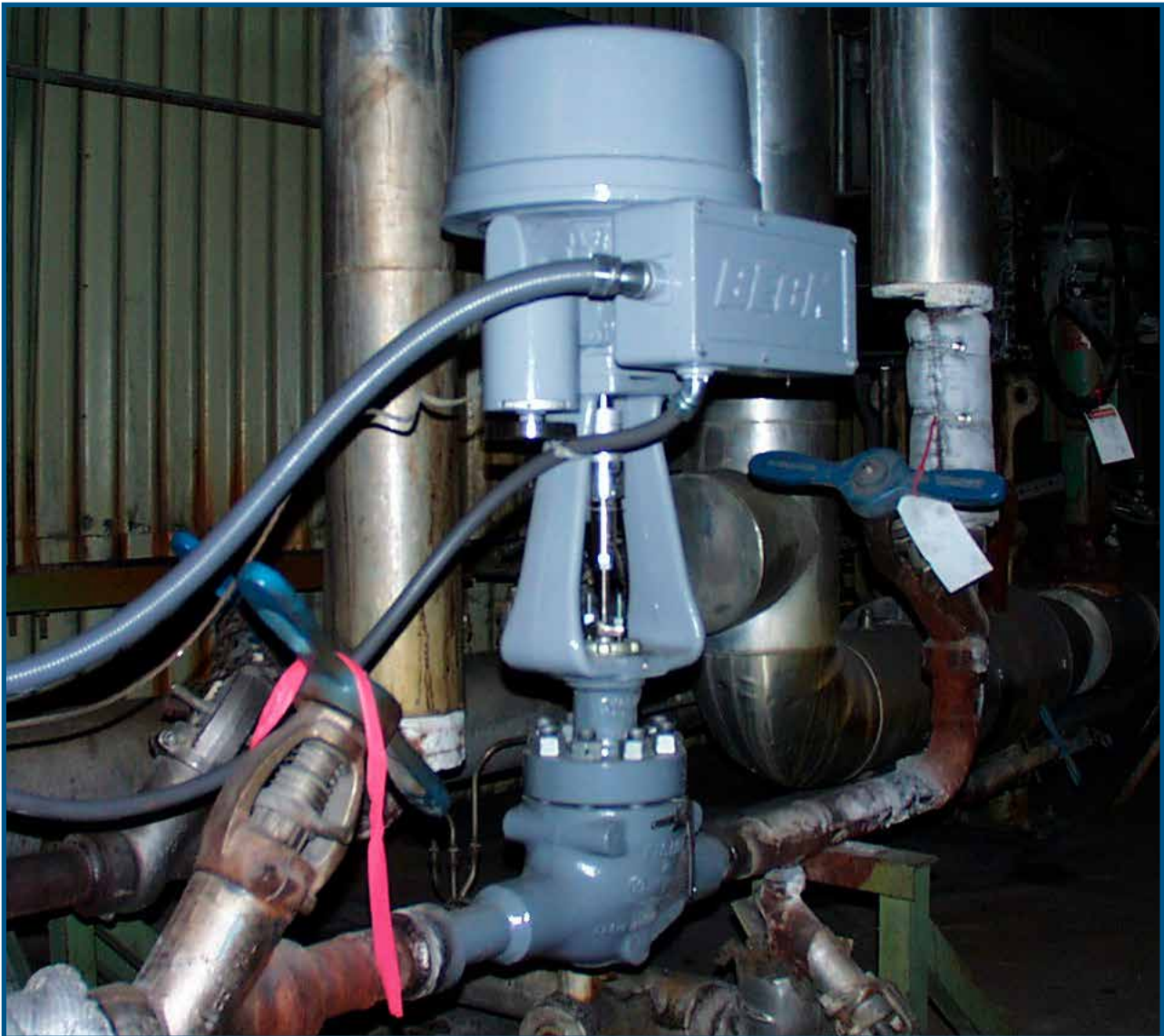

*with HART or
Foundation Fieldbus
Interfaces*

INSTRUCTION MANUAL

For actuators equipped with the
DCM-3 (built after July 2016)



INTRODUCTION / TABLE OF CONTENTS

This manual contains the information needed to install, operate and maintain Beck Model Group 14 electric actuators equipped with the Digital Control Module (DCM-3), manufactured by Harold Beck & Sons, Inc. of Newtown, Pennsylvania.

The Group 14 linear actuator is a powerful control package designed to provide precise position control of globe valves and other devices requiring up to 1,800 lbs (8010 N) of thrust.



NOTICE: This manual contains information that will make installation simple, efficient and trouble-free. Please read and understand the appropriate sections in this manual before attempting to install or operate your actuator.

General Specifications	3
Outline Dimension Drawings	7
Installation	8
Electrical	10
Startup/Operation	14
Digital Control Module (DCM-3)	16
Features	16
Configuration	20
Control End	32
DCM-3 HART®	36
Menus	36
Messages	46
Foundation Fieldbus	50
Parameters	50
Transducer Block	52
Troubleshooting	60
Electronics w/ Foundation Fieldbus	62
Electronics w/ HART®	66
DCM-3 Serial Interface	68
Setup	68
Commands	69
Maintenance	77
Routine	77
Component Replacement	77
Appendix	81
Spare Parts	81
Components	82
Index	84
Services	85

GENERAL SPECIFICATIONS

The Group 14 product line is a family of linear electric actuators designed for precise, reliable operation of globe valves requiring up to 1,800 lbs (8010 N) of thrust. Group 14 actuators consist of a motor actuator gear box with self-contained, micro-processor-based electronics for modulating control. This section describes the main components and general functions.

HOUSING

Beck actuators have individual cast aluminum compartments for the main components: The control motor, wiring terminal board / Digital Control Module (DCM-3), drive and control end. Gasketed covers and sealed shafts achieve Type 4 enclosure ratings ideally suited to outdoor and high humidity environments.

Heavy cast internal mechanical stops for the output shaft are designed to prevent accidental over-travel damage during manual cycling.

ACTUATOR

The Group 14 actuator consists of a control motor, SLM, Handwheel, reduction gears, main gear, and power screw output shaft. The ductile iron main gear and the bronze nut and stainless steel power screw output shaft are common to units of a particular range of thrust and timing. The steel reduction gears are part of the field changeable gear housing assembly. Different combinations of output gear, housing assemblies, and actuator motors determine the actuator's output thrust, timing and stroke adjustment.

The output shaft travel is limited by mechanical stops. The mechanical stop for the fully extended or lower limit of the output shaft travel is not adjustable. The position of the retracted or upward travel mechanical stop is determined by the number of washers on the output shaft between the Tight-Seater™ and the lower bearing plate. This is factory-set for the amount of travel specified at the time of the order and is generally not changed in the field.

CONTROL MOTOR

The Beck control motor is a synchronous motor that operates at a constant speed of 72 RPM (60 Rpm at 50 Hz). Typically, motors reach full speed within 25 milliseconds and stop within 20 milliseconds.

Beck motors have double grease-sealed bearings and require no maintenance for the life of the motor.

SELF-LOCKING MECHANISM (SLM)

An integral part of every control motor is the self-locking mechanism. This mechanical device couples the motor to the gear train and transmits full motor torque in either direction. When the motor is de-energized, the SLM prevents backdriving of the output shaft.

HANDSWITCH

All Group 14 actuators are equipped with a Handswitch for local electrical control. Refer to MODES OF OPERATION (page 15).

WIRING TERMINAL BLOCK

All field wiring connections are made in the terminal block compartment. Refer to INSTALLATION—ELECTRICAL (page 10).

DIGITAL CONTROL MODULE (DCM-3)

In Automatic mode, power to run the motor is controlled by the DCM-3 circuit board assembly. This circuit board receives signals from the

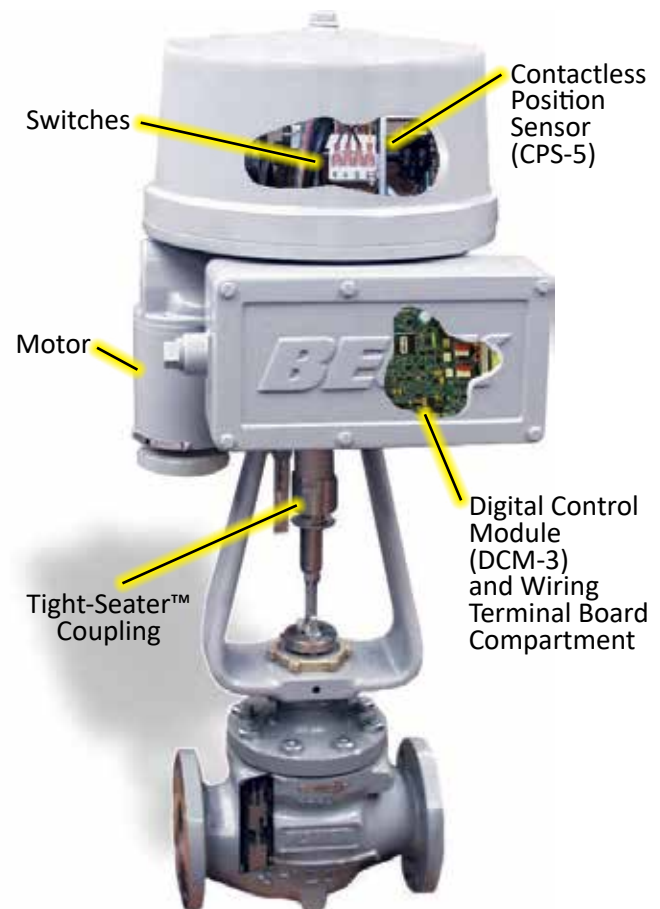

GENERAL SPECIFICATIONS

external control system, interprets the signal as an intended output shaft position, then runs the motor until the output shaft matches that position. The DCM-3 also contains most configuration information, maintains statistics related to actuator performance, and creates signals to send back to the external control system.

ADCM-3 model is available that communicates with Foundation Fieldbus (FF) networks, and a model is available that communicates with HART Communication Foundation (HART) networks. The FF models communicate using digital signaling. The HART models can receive and send analog and/or digital signals. The HART models include a local configuration interface for analog control systems that do not use the HART protocol. All models have a "DB9" serial interface that can be used for configuration and diagnostics. Refer to DCM-3 OVERVIEW (page 16).

CONTROL END

The control end provides electronic and electro-mechanical sensing of the output shaft position. Electronic sensing is provided by the CPS-5 Contactless Position Sensor, which provides a signal to the DCM-3. The DCM-3 uses this signal to determine the actual position of the output shaft. Electro-mechanical sensing is provided by sets of cam-operated switches. Two of these switches act as over-travel limit switches to ensure the motor cannot drive the output shaft beyond the desired range. Other switches are available to the external control system for indication and interlock functions. Refer to OUTPUT SHAFT POSITION SENSING (page 26) for information related to the DCM-3 interaction with the CPS-5 signal. Refer to CONTROL END OVERVIEW (page 32) for information on setting up the control end.

SERIAL NUMBER

The Beck serial number is important in several respects. The serial number begins with Group number, which is followed by the model number. These numbers allow a person to determine the specifications of the actuator. The model number is followed by the sales order number. Using the sales order as an index, Beck maintains complete build information for every actuator built.

The serial number is stamped into the nameplate, which is fixed to the outside of the actuator housing.

The serial number is also useful to the DCM-3. Using the serial number, the DCM-3 can determine the Group and model numbers, and from these can determine what product-specific configurations are available.

The format of the serial number is:

GG MMM-SSSSSS-LL-XX
e.g., 14-109-113065-01-02

where GG is the Group number
MMM is the model number
SSSSSS is the sales order number
LL is the sales order line item number
XX is the sales order sequence number

When entering the serial number into the DCM-3, use the dashes as shown. The Group and model numbers are mandatory entries because the DCM-3 identifies model-specific configuration information from these fields. The sales order information is useful for documentation, but is not needed by the DCM-3. For information on how the DCM-3 uses the serial number information, refer to OUTPUT SHAFT POSITION SENSING (page 26).

TIGHT-SEATER™

The Beck Tight-Seater™ assembly is a pre-loaded coupling that is installed between the actuator output shaft and the valve stem. It produces a controlled positive pressure against the valve seat, independent of actuator thrust.

The Tight-Seater™ consists of four parts: A housing attached to the output shaft, linear thrust discs contained in the housing, a flanged coupling attached to the valve stem, and a threaded ring to contain the flanged coupling in the housing and to allow adjustment of the pre-load on linear thrust discs.

The factory pre-load, by a threaded ring, ensures that no relative motion occurs between the flanged coupling and housing during normal valve operation until the pre-load thrust is exceeded in the seated plug position of the valve.

When the seated plug position of the valve is reached, the flanged coupling on the valve stem is stationary, and the output shaft exceeds the pre-load pressure of the Tight-Seater™. When the pre-loaded pressure is exceeded, the housing will compress the linear thrust discs, maintaining a controlled pressure on the valve seat, with the shaft stationary.

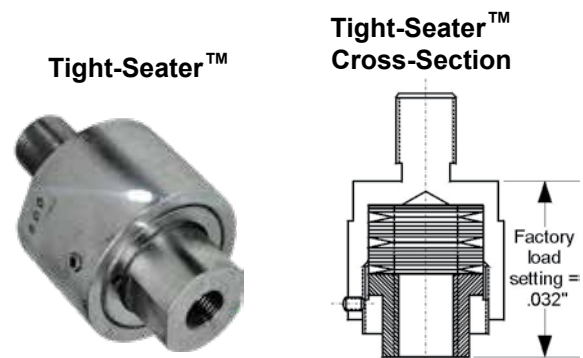

Actuator Power	120 Vac, single-phase, 60 Hz (Standard), 50 Hz (Optional) 48, 72 or 180 watts 240 Vac, 50 or 60 Hz (Optional)	Allowable Tolerance	+10% -15%
Model	Maximum Current and Power		
	120 Vac		240 Vac
14-109	.56 A	72 W	.33 A 80 W
Operating Conditions	-40° to 185°F (-40° to 85°C) 0 to 100% relative humidity, non-condensing		
Communication Interface	HART protocol (Rev. 5 -- burst mode is not supported), local pushbutton/LEDs and local DB9 serial commands FOUNDATION FIELDBUS and local DB9 serial commands.		
Demand (analog) Signal Options (not available w/ FF)	4–20 mA (1–5 Vdc input is possible with the removal of the "R11" resistor located on the DCM-3 board. For resistor location, refer to DCM-3 LAYOUT (page 16))		
Adjustability for Split Range Operation	0%: 0.1 V to 4 Vdc 100%: 0% + 1 V min. to 5 V max.		
Minimum Step Size	0.1% typical (page 20)		
Linearity	±1% of span, max. independent error		
Hysteresis	0.25% of span at any point		
Demand Signal Characterization	Linear: Actuator output shaft moves proportionally to the input signal Square: Actuator output shaft moves proportionally to the square of the input signal Custom: Actuator output shaft moves according to the custom demand response curve		
Position Feedback Analog Signal for Remote Indication	4–20 mA (digital representation only with Foundation Fieldbus).		
Isolation	Demand input and position Feedback signals are isolated from ground and the ac power line. Signal buffering provides 24 Vdc isolation between the Demand and Feedback signals.		
Action on Loss of Power	Stays in place		
Action on Loss of Input Signal (Power On)	Stays in place or actuators to any preset position (configurable).		
Stall Protection	If the motor tries to run in one direction for more than 300 seconds (configurable from 30 to 450 seconds), the DCM-3 will shut off power to the motor (feature can be enabled/disabled).		
Alarm Annunciation	Available at field wiring terminals, typically terminal E. Refer to page 21.		

GENERAL SPECIFICATIONS

Temperature Indication	Measures the internal temperature of the actuator and triggers an alarm when the temperature exceeds the rating range. Refer to page 20.
Over-travel Limit Switches	Two SPDT (Retract and Extend) provide over-travel protection. Refer to page 36.
Auxiliary Switches	Up to four 6 A, 120 Vac switches available. Switches are labeled S1 to S4 and are cam-operated, field-adjustable. Refer to page 34.
Handswitch	Permits local electrical operation, independent of controller signal. Standard on all units. An optional auxiliary contact can provide remote AUTO indication (rated 2.5 A at 120 Vac).
Handwheel	Provides manual operation without electrical power. Refer to page 15.
Motor	120 Vac, single-phase, no-burnout, non-coasting motor has instant magnetic braking. Requires no contacts or moving electrical parts.
Gear Train	High-efficiency, precision-cut, heat-treated alloy steel and ductile iron spur gears. Interchangeable gear modules permit field change of timing.
Stroke Adjustment	Calibar simultaneously adjusts the stroke length, position feedback signal, over-travel limit switches and auxiliary switches. The new stroke displacement is produced by the full input signal.
Mechanical Stops	Prevent overtravel during automatic or manual operation. Refer to page 32.
Enclosure	Precision-machined, aluminum alloy castings painted with corrosion-resistant polyurethane paint provide a rugged, dust-tight, weatherproof enclosure. Type 4; IP66.
Mounting Orientation	Any orientation—no limitations.
Standards*	CSA Labeled (US & Canada); CE Compliant; UKCA Compliant

*NOTE: May not be available with all options and models. For more information, please call Beck at 215-968-4600.

Basic Model	Thrust (lbs. / N)	Timing -- sec./in. (sec./cm.)				Dimensional Data
		@ 60 Hz		@ 50 Hz		
14-100	340 / 1513	4	(1.6)	5	(2)	Page 7
	425 / 1891	11	(4.3)	13	(5.1)	
	600 / 2670	16	(6.3)	19	(7.5)	
	650 / 2893	8	(3.1)	10	(3.9)	
	800 / 3560	11	(4.3)	13	(5.1)	
	1,000 / 4450	27	(10.6)	32	(12.6)	
	1,100 / 4895	16	(6.3)	19	(7.5)	
	1,620 / 7209	48	(18.9)	57	(22.4)	
	1,800 / 8010	27	(10.6)	32	(12.6)	

OUTLINE DIMENSION DRAWINGS

5/16 [8] to 2 1/8 [54] travel

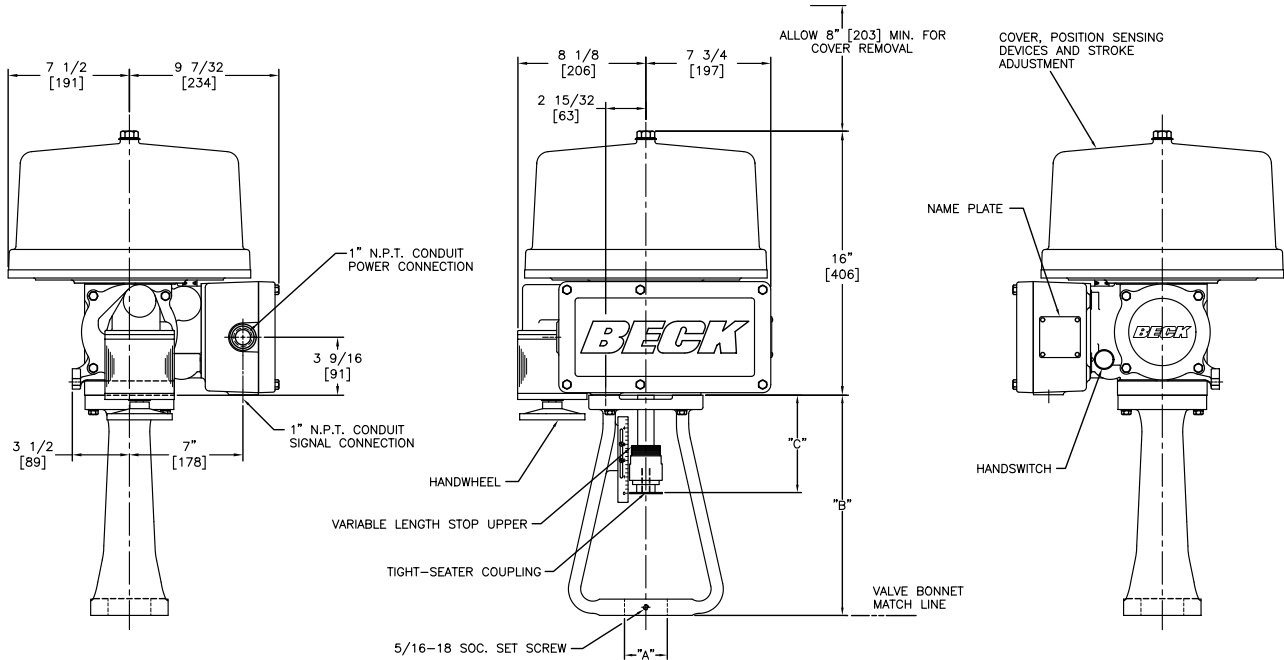

3/4 [19] to 4 1/2 [114] travel

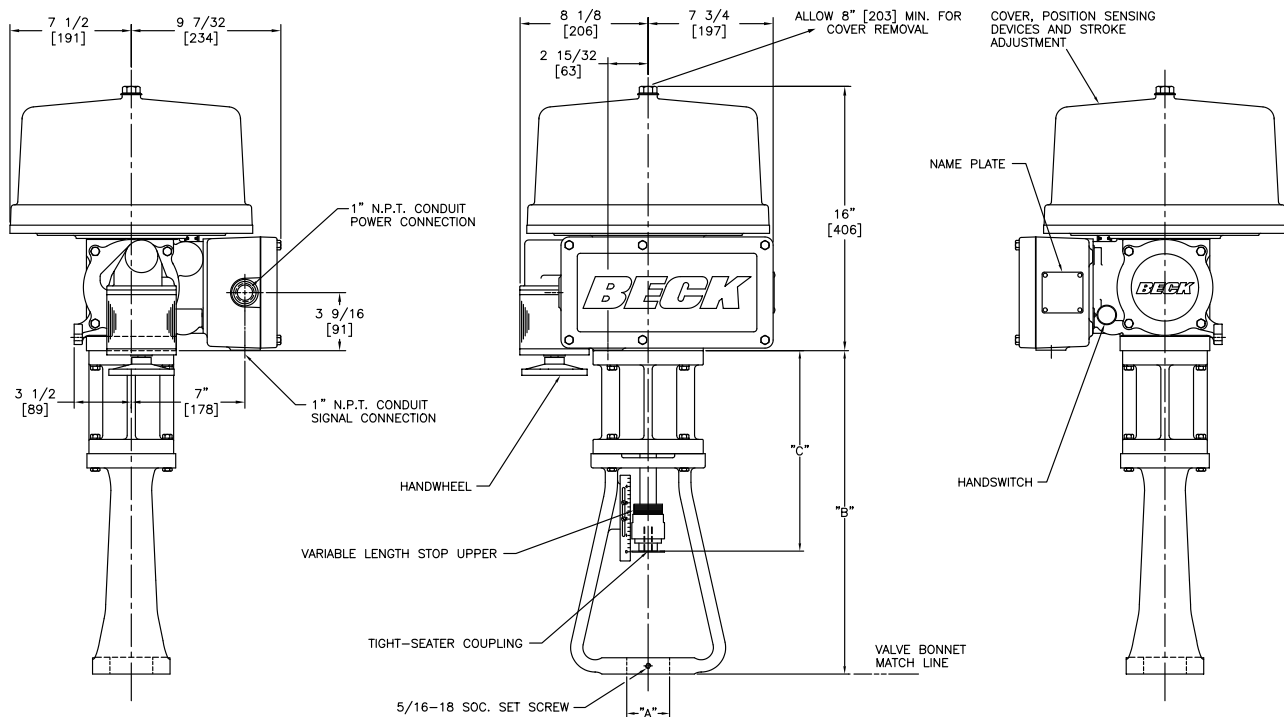

NOTE: Actuators may be mounted in any orientation. Dimensions in inches & [mm].

Drive Shaft Travel Range (in) [mm]	"A" Valve Boss Dia. Range (in) [mm]	"B" Yoke Height (in) [mm]	"C" Nominal Drive Shaft Extension (in) [mm]	Max. Valve Stem Extension (Valve Stem Retracted) (in) [mm]	Approx. Weight (lb) [kg]
5/16-1 3/4 [8-44]	1-2 5/8 [25-67]	8 [203]	4 3/16 [106]	5 1/2 [140]	80 [36]
3/4-2 1/8 [19-54]	1 3/8-3 3/4 [35-95]	13 1/2 [343]	6 [152]	9 1/4 [235]	92 [42]
3/4-3 1/2 [19-89]	1 3/8-3 3/4 [35-95]	19 13/16 [503]	12 5/16 [313]	9 1/4 [235]	100 [45]
1 3/4-4 1/2 [44-114]	1 3/8-3 3/4 [35-95]	19 13/16 [503]	12 5/16 [313]	9 1/4 [235]	100 [45]

INSTALLATION

SAFETY PRECAUTIONS



WARNING

Installation and service instructions are for use by qualified personnel only. To avoid injury and electric shock, do not perform any servicing other than that contained in this manual. Please read and understand the appropriate sections in this manual before attempting to install or operate your actuator.

STORAGE INFORMATION

The actuator should be stored in its shipping carton in a clean, dry area.

If it is necessary to store the actuator outdoors for a long period of time, it should be removed from its shipping carton and stored above ground. A waterproof cover should be securely fastened over it. Do not stack actuators on top of one another. Stored actuators should be periodically checked to make sure no condensation has formed in the control compartments. Damage due to moisture while in storage is not covered by warranty.

UNPACKING

Group 14 actuators are packed in standardized cardboard shipping containers. Actuators mounted on valves may be packed in cardboard containers or strapped to a skid and crated, depending on size. After unpacking, the wooden platform may be used to transport the actuator to the installation site.

INSTALLATION—MECHANICAL

Beck actuators can be furnished with valves mounted as unitized assemblies ready for pipeline installation.



CAUTION

Whenever an actuator is being mounted on a valve, it is good practice to remove the valve from service. Observe the following precautions:

- Know what fluid is in the line.
- Wear proper protective equipment.
- Disconnect the electrical power.
- Depressurize the pipeline.
- Refer to the valve maintenance manual for specific instructions.

INSTALLATION Electrical

Electrical installation requires the connection of AC line power and the connection of signal wiring. Without line power, the motor cannot run and digital communications will not be functional. Never connect power lines to signal connections.

The AC power is typically 120 Vac or 240 Vac. Check the actuator nameplate. The signal type is determined by the DCM-3 circuit board, and can be either Foundation Fieldbus (page 18) or analog/HART (page 18). Check the purchasing documents for DCM-3 signal compatibility.

NOTE: The technicians installing the equipment are responsible to make certain the equipment installation is compliant to national and local electrical codes.

Two conduit connections are provided for supplying power and signal wiring to the unit. Temporary plugs are installed in the conduit entrances at the factory for shipping only and are not intended for permanent use.

Conduits should be routed from below the actuator so that condensation and other contaminants flow away from the conduit. Prior to actuator operation, all conduit entrances must be properly sealed in accordance with National Standards or Regulatory Authorities.

To maintain signal integrity and meet most electrical codes, power and signal wires must be routed to the actuator separately. The signal wiring should be either shielded cables or be installed in conductive conduit and/or cable trays.

Beck motors have negligible inrush current, so wiring overload protection can be set only moderately above the actuator rated current.

Beck actuators must always be properly grounded.

A large, clearly labeled terminal block on the side of the actuator is enclosed in a gasketed metal enclosure. Terminals will accommodate up to 12 AWG (3.31 mm²) wiring. For the location of the terminal block compartment, refer to the actuator outline drawing on page 7.



**Field Wiring
Terminals**

Beck actuators are shipped calibrated and tested to the customer's specifications that were written into the equipment order. If your actuator does not appear to match the system requirements, the actuator configuration may be able to be modified for a better match. If the mismatch appears too large to correct with configuration changes, contact the Beck factory.

All Beck actuators are shipped with a wiring diagram that shows the correct wiring for that actuator. Always refer to that wiring diagram to be certain the correct connections are being made. If the actuator internal wiring is changed in the field, be certain the attached wiring diagram is updated.

Typical Wiring Connections, Foundation Fieldbus

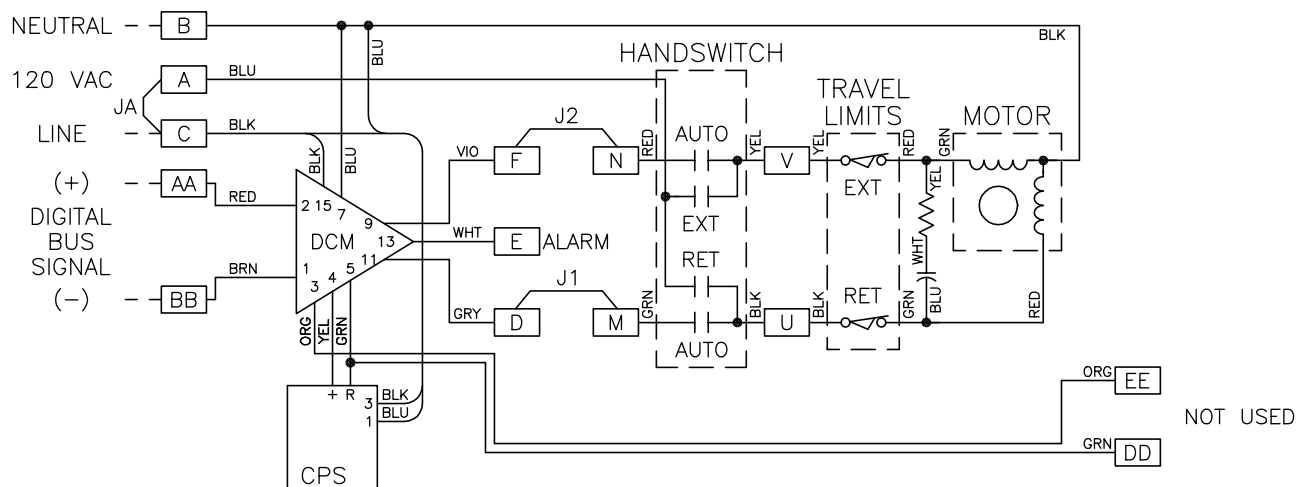

FOUNDATION FIELDBUS COMMUNICATION OVERVIEW

The Foundation Fieldbus communication interface is a method of superimposing digital data onto a DC voltage power supply bus. Details and specifications of the interface are maintained by the Fieldbus Foundation.

The Foundation defines a large list of predefined function blocks and defines the method of using these function blocks. The Beck DCM-3 includes five blocks: One Resource Block, one Transducer Block and three function blocks.

1. Resource Block

This block is a fieldbus requirement, and is not directly used in controlling the Beck actuator. This block is a standard block as defined by Fieldbus Foundation, and resembles all other standard Resource Blocks.

For typical automatic operation, this block must be in Auto mode.

2. Transducer Block

This block is a fieldbus requirement, and is generally not directly used in controlling the Beck actuator. The Transducer Block is used to read and write actuator-specific calibration, configuration, and status information. Calibration and configuration information will have a significant effect on the performance of the actuator. For example, the direction of rotation for an increasing set point is determined by a setting in this block.

When installing the actuator pay particular attention to Actuator Dir (Actuator_INFO2.Actuator_DIRECTION) to configure the direction of actuator movement in response to an increasing actuator set point (page 30).

For typical automatic operation, this block must be in Auto mode, and the Op Mode parameter (Actuator_OPERATING_MODE) set to Hold.

3. Analog Output (designated Channel 1)

This is a standard Analog Output function block as defined by Fieldbus Foundation, and is used to control the Beck actuator. Because it is a standard Analog Output block, it resembles all other standard Analog Output blocks.

Apply the actuator set point to CAS_IN. The actuator set point is typically scaled in "percent." This set point is propagated to Transducer Block variable "Demand" (DEMAND_VALUE).

For typical automatic operation, set Channel to 1, set SHED_OPT to NormalShed_NormalReturn, and set the mode to Cas|Auto. For information on how the actuator utilizes Demand, refer to DEMAND (page 22).

4. Analog Input (designated Channel 2)

This is a standard Analog Input function block as defined by Fieldbus Foundation, and is used to measure thrust load on the output shaft. This function is not available with the Group 14.

5. Analog Input (designated Channel 3)

This is a standard Analog Input function block as defined by Fieldbus Foundation, and is used to measure the internal temperature of the actuator. Because it is a standard Analog Input block, it resembles all other standard Analog Input blocks.

Minimum and maximum recorded temperatures can be viewed in the Transducer Block. For typical operation, set Channel to 3, and set L_TYPE to Indirect. For more information on temperature sensing, refer to TEMPERATURE SENSING (page 20).

INSTALLATION *Electrical*

ANALOG CONTROL OVERVIEW

Actuators equipped with a HART / Local style DCM-3 (P/N 20-5014-59) use a standard 4–20 mA analog input signal for positioning. This design is capable of providing very accurate control. Access to configuration parameters and status parameters requires a HART interface or a serial interface.

Simple Position and Demand setup, as well as simple diagnostics can also be accessed using the pushbutton / LED interface on the DCM-3 board. For information on the Demand adjustment, refer to page 31; for information on the output shaft position, refer to page 27.

When installing the actuator, give attention to the direction the output shaft moves in response to an increasing Demand signal. For more information on travel direction, refer to page 27.

HART COMMUNICATION OVERVIEW

The HART communication interface is a method of superimposing digital data onto what appears to be a conventional 4 mA to 20 mA control signal. Details and specifications of the interface are maintained by the HART Communication Foundation (HCF).

In a typical HART application, the HART signals share the two wires typically used for Demand in analog systems. HART specifically targets analog systems based on the 4 mA to 20 mA, 250 ohm signaling convention. If the resistance in the loop is significantly higher or lower than 250 ohms, digital communication may fail. HART communication frequencies are 1200 Hz and 2200 Hz. Instruments powered from the mA signal may not have a measurable resistance of 250 ohm, but must have signal filtering so the resistance appears to be 250 ohm at the communication frequencies. Resistance of 250 ohm must terminate the connection. Consistent with the connection scheme for actuators, Beck uses a passive 250 ohm resistor on the DCM-3.

The HART communication system is based on cyclic device polling. The control system initiates writing and reading data.

HCF specifies the format of the data and some of the data content, but most of the data communicated is at the discretion of the field device manufacturer, such as Beck. The DCM-3 HART interface has access to a large set of data. To access this data, the technician's HART communication device must be aware of what data is available. This data awareness is controlled by what is called a Device Description (DD). The Beck DD for the DCM-3 is registered with HCF and is available from HCF. The proper DD is described by the manufacturer number (Beck is 0x68) and the DD number (0xEF).

For compatibility with older DCM installations, the DCM-3 is able to be set to communicate with HART devices using an older DD. However, the older DD does not give access to all the DCM-3 functionality, and this DD should only be used if the newer DD is not available. This older DD is denoted by the same Beck manufacturer number (0x68) and a different DD number (0x01).

As defined by the HART protocol, a field device can identify only one compatible DD type. Therefore, to have the DCM-3 identify an older DD type, an internal DCM-3 configuration change is necessary. This is accomplished by using the BCP command harttype (page 74). This command tells the DCM-3 which DD number to send to the host. There are presently three DD's created by Beck and registered with HCF. Depending on the documentation system, the DD's may be represented by the decimal values 1, 2, 239, or may be represented by hexadecimal values 0x01, 0x02, 0xEF, respectively.

HART PRESENTATION OF DATA

Data available over the HART network is independent of the type of host used to read the data. Presentation of the data on a computer screen is controlled by the host, and is not specified by the HART or Beck protocol.

The protocol does specify a menu system, and the DD contains the information needed by the host to construct the menu system. This instruction manual describes the HART interface based on the menu system as included in the Beck DD (DD number 0xEF).

SERIES CONNECTED OPERATION

In some applications, two or more Beck actuators may have the Demand signals connected in series to operate multiple actuators from the same signal. In this situation, the loop resistance increases by 250 ohms for each Beck actuator. If the Demand signal from the control system is an analog signal and can drive the resistance created by placing the actuators in series connection, the analog system will operate as intended. Note that this configuration can obstruct HART communication.

HART is not intended to be used with series connected devices. Therefore, the control system will not be able to communicate with the series connected actuators. However, each actuator will be able to be accessed one at a time if a local HART host is connected directly across the Demand signal of that actuator.

PARALLEL CONNECTED OPERATION

In some applications, two or more Beck actuators may have the Demand signals connected in parallel to operate multiple actuators from the same signal. In this situation, the loop resistance should be maintained at 250 ohms for the entire parallel connection. This is usually accomplished by removing the 250 ohm resistor from all DCM-3's, then adding a parallel 250 ohm resistor across the field wiring terminals of one actuator. In this situation, the loop remains at 250 ohm, the voltage generated across the 250 ohm resistor is 1 Vdc to 5 Vdc, and each DCM-3 Demand sensing circuit is fed the same voltage. If any DCM-3 is removed, the voltage across the parallel connection does not significantly change. If the actuator with the resistor is disconnected, the loop resistance becomes too high.

HART can communicate with parallel connected actuators because the loop remains at 250 ohm and all DCM-3 have access to the same loop wires. In this situation, the polling addresses of each DCM-3 should be made unique.

Unless otherwise specified, the polling address of each DCM-3 is set to 0, the HART standard for single devices. If multiple actuators are sharing the Demand loop, the polling addresses should be changed before adding the actuator to the loop. If there are two polling addresses the same, the HART host will not be able to communicate. The Beck Configuration Port can change the polling address regardless of whether the actuators are already installed in parallel.

To change the polling address:

HART Modify parameter Poll addr.
BCP polladdr

Generally, HART hosts look first for a device at polling address 0. Looking for devices at other addresses is called polling the bus. Some hosts may not automatically poll the bus.

START-UP/OPERATION

START-UP INSTRUCTIONS

After the actuator is mounted and its wiring connections are made, it is ready to be tested for proper operation.

Turn on the power supply. Operate the actuator with the Handswitch and run it through its full stroke, both directions. Observe that the actuator device travels through its desired stroke. If satisfactory, set Handswitch at the "AUTO" position.

Turn on the controller and operate the actuator by varying the control signal. Check that the valve strokes in the proper direction for a change in control signal. An increasing control signal retracts the shaft and opens the valve. With a 100% signal, the actuator is fully retracted. If the valve does not stroke in the proper direction, first check for proper wiring connections and verify the control signal at the actuator. If the wiring is correct, then reverse the direction of travel (see page 27).

Valve Seating Adjustment

The actuator has a Tight-Seater™ attached to its output shaft. The Tight-Seater™ allows tight seating of the valve plug. It is a pre-loaded coupling that allows the valve plug to seat before the actuator reaches its lower limit. The additional amount of travel compresses the thrust discs inside the Tight-Seater™, causing a controlled amount of thrust to hold the valve plug on its seat when the actuator stem reaches its lower limit. The Tight-Seater™ is factory-set to produce a thrust matched to the valve and should never be disassembled. Control of the amount of valve stem threaded into the Tight-Seater™ may be used to adjust the valve seating.

If readjustment of valve seating is necessary, proceed as follows:

1. With the Handswitch, run the actuator to a position above the 0% or lower limit position.
2. Loosen the lock nut on the valve stem and thread the valve stem into the Tight-Seater™.
3. Run the actuator to the 0% position, using a Demand signal source.
4. Thread the valve stem out of the Tight-Seater™ until the plug seats in the valve.
5. Raise the actuator shaft using the Handswitch until the plug is clear of the seat and there is sufficient clearance to make the following adjustment.

6. Thread the valve stem out of the Tight-Seater™ a fraction of a turn according to the valve stem thread as listed (1/32" travel):

Thread	Turn
3/8-24	3/4
7/16-18	5/8
1/2-20	5/8
3/4-16	1/2

7. Tighten the lock nut and index disc on the valve stem.
8. Run the actuator to its lower limit using the Handswitch. The valve stem should stop before the actuator shaft stops.
9. Reposition the travel index.



CAUTION

If the valve stem is threaded directly into the actuator shaft without a Tight-Seater™, the valve stem should be at least 1/4 turn from the seated plug position when the actuator shaft reaches the lower limit. This will prevent damage to the valve stem or seat. Do not attempt to obtain tight shut-off without a Tight-Seater™ as serious valve damage may result.

MODES OF OPERATION

There are three basic modes of actuator control:

1. Handwheel operation
2. Handswitch operation, which is local electrical control
3. Automatic mode, which is remote electrical operation

The maximum available actuator travel is dependent on the specific actuator model. Refer to Drive Shaft Travel Range (page 7).

HANDWHEEL

Every Beck actuator is furnished with a Handwheel to permit manual operation of the valve or damper without electrical power. Its solid construction design includes no spokes or projections, and turns at a safe, slow speed. The Handwheel is located at the bottom of the control motor housing. The Handwheel is coupled directly to the motor shaft and travels when the motor runs. Before using the Handwheel, place the Handswitch in the "STOP" position. Manual operation of the Handwheel (with electric Handswitch in "STOP" position) turns the motor and the rest of the drive without incorporating a clutch.

Handwheel operation can be used at any time, but is particularly useful during initial installation or when power is not available. The Handwheel can also be used as an indication of motor movement.

HANDSWITCH

Handswitch operation allows manual electric control at the valve. In the "STOP" position, the motor is electrically blocked from running. As a safety feature, the Handswitch is designed so that the controller can operate the actuator only when the Handswitch is in the "AUTO" position. In the "RETRACT" or "EXTEND" positions, the motor runs to move the output shaft in the corresponding direction. Refer to DIRECTION OF OUTPUT SHAFT TRAVEL (page 28) for information on interpreting the output shaft movement direction.

When moving the output shaft using the Handswitch, the motor will stop when the over-travel limit switches are actuated.

To prevent the Handswitch "RETRACT" and "EXTEND" positions from running the motor, remove the jumper between field wiring terminals A and C (page 10).



WARNING

AC power to the actuator must be off before removing the jumper.

AUTOMATIC

The actuator is in Automatic mode when the Handswitch is in "AUTO." In this mode, the motor runs to move the output shaft to a position as determined by a control system. The control system signal to the actuator is called the Demand signal and it can take several forms:

1. 120 Vac pulsed control
2. Analog control signal such as 4 mA to 20 mA
3. Digital network control

This instruction manual describes actuators that accept analog signals, combined analog/digital signals, and purely digital signals.

Regardless of the signaling technology, basic automatic operation of the actuator is the same: The motor runs so the percent of output shaft angle matches the percent indicated by the Demand signal. Proper configuration of the actuator assures the proper relationship between the Demand signal percentage and the shaft angle percentage. All Beck actuators are shipped from the factory configured as specified on the customer order.

In Automatic mode, motor voltage is controlled by a computerized circuit board called the DCM-3. Refer to the image on page 4 for the typical location of the DCM-3.

MODE INTERACTION WITH SIGNALS

The mode of operation can interact with various actuator signals and diagnostic functions. As described in AUTOMATIC, the Demand signal does not operate the actuator unless the Handswitch is in "AUTO." With the Handswitch in other modes, the actuator monitors the Demand, but Demand does alter the output shaft position.

Beck actuators also provide a signal output so the control system can monitor the output shaft position. This output signal is called Feedback, and is available in all operating modes.

The DCM-3 computerized circuit board in the Beck actuator monitors and records many conditions and events. Some of these conditions and events are not recorded or are not effective in Handwheel or Handswitch modes. For example, the DCM-3 does not count the number of motor starts in Handwheel or Handswitch modes.

DCM-3 Features

DCM-3 OVERVIEW

This instruction manual describes two basic types of DCM-3. One type is compatible with Foundation Fieldbus networks, and one type is compatible with HART networks and analog signals.

The DCM-3 is a computerized circuit board that receives the Demand signal from the control system, monitors the position of the output shaft, and runs the motor to move the output shaft to match the Demand signal. The DCM-3 also provides alarms and status information back to the control system, contains indicating LED's for local indication, and records information related to actuator performance.

Output shaft position sensing is performed by a circuit board located in the Control End called the CPS-5. The CPS-5 sends a signal directly to the DCM-3. Refer to the image on page 4 for the typical location of the CPS-5.

Although configuration information is stored in the DCM-3, the Control End applies some limitations on the DCM-3 functionality. For example, the DCM cannot cause the output shaft to travel beyond the settings of the over-travel limit

switches that are located in the Control End. The Control End is shipped from the factory entirely configured and tested, and most applications will not require changes. For more information on the Control End, refer to OUTPUT SHAFT POSITION SENSING (page 28), and CONTROL END OVERVIEW (page 32).

Except for the interface being either Foundation Fieldbus or HART/analog, most aspects of the DCM-3 models are the same regardless of the network type. For example, both models have adjustable step size, measure the output shaft position by monitoring the signal from the CPS-5, and have the ability to measure ambient temperature. Both models store the same statistical data. The different interface circuitry makes the models specific for each interface.

DCM-3 PHYSICAL LAYOUT

DCM-3's differ based on the required control system interfaces, but all are physically interchangeable and have common features. The physical interchangeability allows for adapting to control system updates. The common features provide a universal foundation for operation.

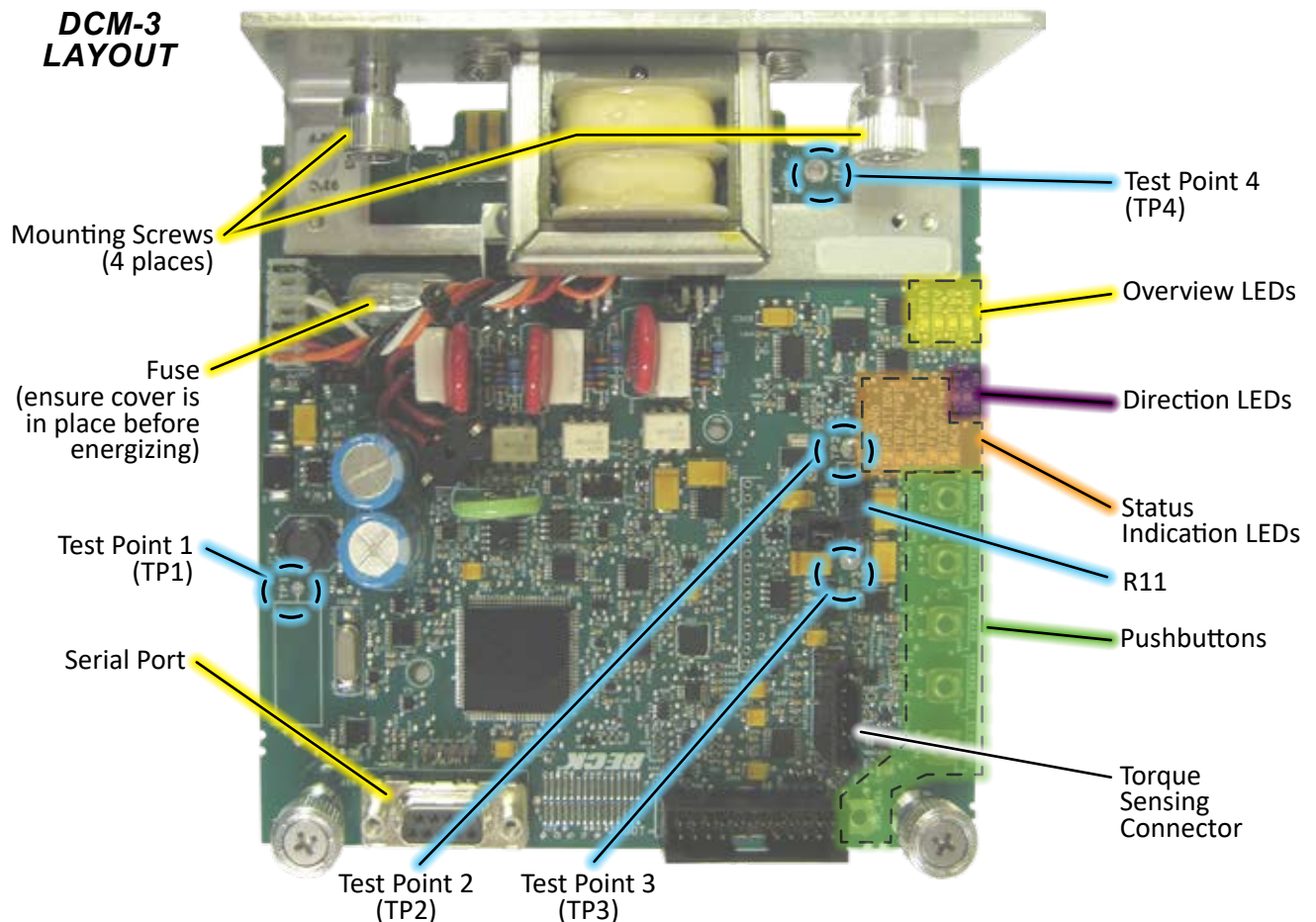

FUSE

A fuse is located in the top left corner of the illustration shown on the opposite page. This fuse protects the motor wiring, but is not necessary for the low power sections of circuit board. Therefore, if the fuse is cleared, the circuit board will appear to function but the DCM-3 cannot run the motor. Because of the very low inrush current of Beck motors, the peak motor current is much lower than the fuse rating. Fuse clearing is extremely rare, and is almost always caused by erroneous customer wiring during installation.

ALARM OUTPUT RELAY

A solid state relay is included to connect line power to an external alarm circuit. Typically, any condition that lights the STAT LED also issues an external alarm through this relay. The choice can be made if the relay indicates alarm by closing or opening. Also, the exact status indications that can signal an alarm can be set through a mask. Refer to ALARM OUTPUT CONFIGURATION (page 21).

BECK CONFIGURATION PORT (BCP)

The Beck Configuration Port is used during Beck factory testing. The port uses traditional "DB9" signaling, and can access all internal DCM-3 parameters and information. This port can be used to configure any DCM-3, but it is not related to Foundation Fieldbus or to HART interfaces. Both Foundation Fieldbus and HART communicate through the Demand signal wiring at the field wiring terminals (page 10).

For more details on using this configuration port, refer to Beck Configuration Port (page 68).

OVERVIEW LEDs

Located on the DCM-3 board (pictured at left), these LEDs indicate the basic, real-time state of the actuator. A description of each LED follows.

STAT

This red LED illuminates during a system alarm. Explanation of the specific alarm is available through the Fieldbus or Serial interface. See the Troubleshooting section for additional information.

REV

This green LED illuminates when the actuator is receiving a Demand signal less than its position.

FWD

This green LED illuminates when the actuator is receiving a Demand signal greater than its position.

PWR

This green LED illuminates when power is applied to the actuator. This LED pulses from bright to dim indicating the DCM-3 is operational.

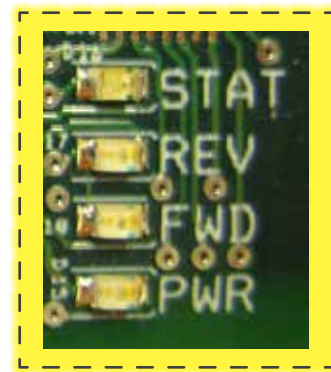

OVERVIEW LEDs

DIRECTION LEDs

These green LEDs indicate the direction of travel resulting from an increasing Demand signal.

**DIRECTION
LEDs**

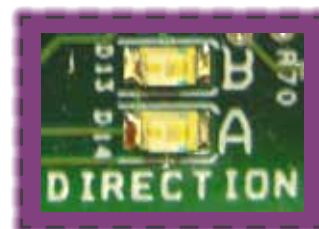

A = EXT B = RET

DCM-3 Features

DCM-3 FOR FOUNDATION FIELDBUS

The Foundation Fieldbus version of the DCM-3 includes a fieldbus-powered interface to permit fieldbus access to the DCM-3 operational parameters.



DCM-3 FOR ANALOG OR HART

The HART version of the DCM-3 interfaces to analog systems and HART systems. This model of DCM-3 includes a pushbutton and LED interface to allow configuration and diagnostic actions without the need of a computer interface. Configuration changes resulting from the pushbuttons can be read through the computer interface.



PUSHBUTTON CONTROLS (not available with Foundation Fieldbus)

The pushbuttons provide a simple method of configuring the Demand and the position sensing ranges. These buttons overwrite internal DCM-3 signal ranging information. If using a HART communicator to configure the actuator, do not also use the pushbuttons. Although the systems fully cooperate inside the DCM-3, the values inserted into the configuration registers may not agree with the values written by the HART communicator.



PUSHBUTTON CONTROLS



When using the pushbuttons, pressing a button will cause the DCM-3 to stop trying to run the motor until the button is released. When pressing any button, LEDs on the local configuration interface panel that were illuminated will temporarily pause from illuminating.

Pressing only one button will cause the DCM-3 to pause, but will not change the configuration. To change the configuration, the CALIBRATE button and the appropriate range button must be pressed together. Either button can be pressed first. Press both buttons until the DCM-3 acknowledges.

The DCM-3 acknowledges successful requests by lighting ACKNOWLEDGE. If signal ranges are inappropriate for the request, the DEMAND or POSITION LED will light.

For instructions on using the pushbuttons, refer to sections DEMAND (page 22) and OUTPUT SHAFT POSITION SENSING (page 28).

STATUS INDICATION LEDs

When the “STAT” LED is lit, the applicable status indication LED(s) (pictured below) will light to reveal the condition(s) as described below.

An external alarm connection is available. Refer to ALARM OUTPUT CONFIGURATION (page 21).

DEMAND

This alarm is caused by the analog Demand signal being out of the accept range. The bottom of the range is defined as described in LOSS OF DEMAND SIGNAL (L.O.S.) (page 23). This alarm can also be set if the Demand signal exceeds approximately 5.5 Vdc.

POSITION

The CPS-5 Position signal to the DCM-3 is out of the selected range limits. Refer to OUTPUT SHAFT POSITION SENSING (page 26).

TRQ/THRUST

This LED is inactive for Group 14 actuators.

STALL

The actuator is in a stall condition and stall protection has been activated. Refer to STALL PROTECTION (page 21).

TEMP °F

Drive’s internal temperature is too low or too high. Refer to TEMPERATURE SENSING (page 20).

FB OPEN

External position Feedback signal is enabled, but not wired to an external load or the wiring has failed between the actuator and the monitoring device. Refer to CONFIGURING FEEDBACK (page 29).

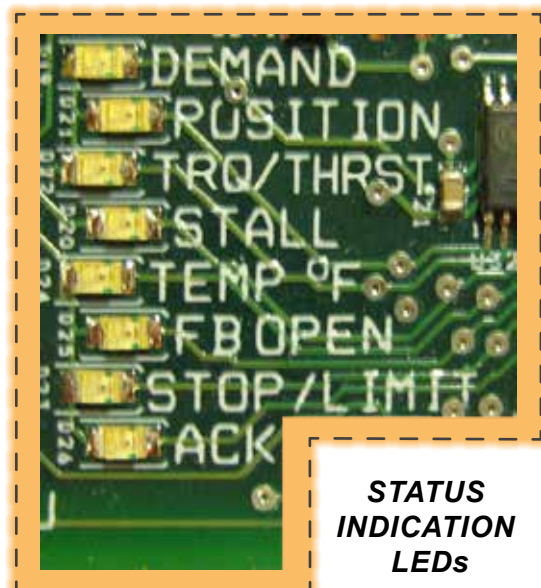

**STATUS
INDICATION
LEDs**

STOP/LIMIT

Handswitch is in “STOP” position or the actuator is at a limit. There is no alarm unless the DCM-3 is trying to run the motor. Refer to STOP/LIMIT INDICATION (page 20).

When more than one status LED is required at one time, the illuminated LEDs will cycle rather than illuminate all at once.

CONFIGURATION INSTRUCTIONS FORMAT

The DCM-3 configuration section of this manual is written from the perspective of identifying configuration concepts, then explaining how to accomplish the configuration with the appropriate configuration tool.

BF

Foundation Fieldbus compatible DCM-3’s must be connected to a Foundation Fieldbus compatible control system. All configuration and diagnostic settings are available through the fieldbus interface. The Foundation Fieldbus DCM-3 does not have a local configuration interface or the associated status LED’s.

HART

HART Communication Foundation compatible DCM-3’s are used in analog control systems. Analog signal configuration is typically part of using a HART communicator. Digital information can also be sent and received over the network.

BCP

This notation indicates commands to enter using the “Beck Configuration Port,” which is available on all models. This port can be used for configuration or diagnostic information.

Local

Some applications are fully analog with no digital communication available. These applications are served by the HART compatible DCM-3. This model has a local configuration interface that allows basic changes to match the control system requirements. The interface also includes status LED’s to assist technicians who do not have the benefit of digital communication.

DCM-3 Configuration

RESTORE FACTORY CONFIGURATION

All DCM-3's ship from the factory configured as specified in the sales order. After this configuration is tested for accuracy, a second copy of the configuration data is electronically written into the DCM-3. This second copy is available in the field to undo configuration changes and return to the configuration that was originally shipped from the factory. Restoring the configuration erases configuration changes, but does not erase data such as stored statistical information.

FF Execute Reset Settings with the option Recall Factory Settings.

HART Execute Restore to Factory.

BCP restoremodes

STEP SIZE

Step size is the incremental movement of the output shaft in response to signal changes. When operating in AUTO mode with the DCM-3 controlling the motor, the DCM-3 runs the motor until the output shaft position matches the percentage of Demand signal. When the correct output shaft position has been reached, the position and Demand are balanced, and the DCM-3 removes power from the motor. From this balance condition, the Demand signal must change by the step size before power is returned to the motor.

The step size is factory set at 0.15% unless otherwise specified at the time of order. The step size is adjustable from 0.1% to 2.5%.

FF Modify the parameter StepSize.

HART Modify the parameter StepSize.

BCP stepsize

TEMPERATURE SENSING

DCM-3s are equipped with an ambient temperature sensing circuit. The present temperature and the temperature extremes are available.

Temperature unit of measure can be selected to be either Fahrenheit or Celsius.

An alarm condition is asserted if the actuator's ambient temperature exceeds the rating of the actuator. This alarm condition is automatically reset when the temperature is brought back within the actuator rating.

This alarm lights the STAT LED, and on models with a local configuration panel, lights the TEMP °F LED.

To read the present temperature:

FF Read parameter Ambient Temp.

HART Read parameter Temp.

BCP temperature

To read the temperature extremes:

FF Read parameters High and Low under Ambient Extreme.

HART Read parameters Low Temp and High Temp.

BCP temperature

To select the unit of measure:

FF Modify parameter Temp Unit.

HART Modify parameter Temperature Unit.

BCP temperature

STOP/LIMIT INDICATION

The DCM-3 monitors the motor current when the Handswitch is in AUTO. If the DCM-3 is trying to run the motor, but does not measure appropriate current, an alarm is generated. The alarm clears automatically if the DCM-3 stops trying to run the motor or if the DCM-3 measures appropriate motor current. This alarm is most often caused either by placing the Handswitch into a mode other than AUTO, or by an output shaft over-travel limit switch blocking motor current.

If the DCM-3 is not trying to run the motor, no alarm is generated. Therefore, placing the Handswitch into a mode other than AUTO will not generate the alarm unless the DCM-3 tries to run the motor.

This alarm lights the STAT LED, and on models with a local configuration panel, lights the STOP/LIMIT LED.

To observe the status of the alarm using a computer interface:

FF Check parameter Operating Status in record DCM BIST.

HART Check parameter Operating Status.

BCP codes

Although the over-travel limit switches are intended to be beyond the normal travel range of the output shaft, some applications are configured so an over-travel limit switch is often actuated. A configuration parameter can be set to modify the Stop/Limit alarm behavior near the ends of travel. This modification suppresses the alarm if the position of the output shaft is beyond the range of 0% to 100%. The concept is: the actuator has

reached the end of travel, so do not create an alarm because the current is being blocked. To suppress the alarm, choose Accept. To allow the alarm, choose Alert.

To change the alarm behavior:

FF Modify parameter LimitSwitch.

HART Modify parameter LimitSwitch.

BCP limitalarm

STALL PROTECTION

The DCM-3 can be configured to shut off power to the motor if the actuator output shaft cannot reach the desired position within a certain time period. The time period can be configured to a value between 30 seconds and 450 seconds. This timer is automatically reset whenever the position signal matches the Demand signal. The timer does not continue to count if the Handswitch is not in AUTO mode or if an over-travel limit switch is blocking power to the motor.

If the Stall timer is set to a time shorter than the travel time of the actuator, Stall alarms will be created erroneously.

Under the Stall condition, the "STAT" and "STALL" LEDs will light. If Stall Protection is disabled, the Stall alarm is created, but power is not removed from the motor.

The number of recorded Stall conditions is available to the computer network.

This alarm is not automatically self-correcting. Any of these actions will eliminate the alarm: reverse the Demand input signal from the controller (such that the actuator tries to run in the direction opposite the blocked direction), perform a "Reset Stall" or "Board Reset", or by switching the actuator power off and on.

To enable or disable Stall Protection:

FF Modify the parameter StallProtect.

HART Modify the parameter StallProt.

BCP stallprot

To select the stall time:

FF Modify the parameter Stall Time.

HART Modify the parameter Stall Time.

BCP stalltime

To read the number of Stall conditions:

FF Read the parameter Stalls.

HART Read the parameter Stalls.

BCP stat

To Reset Stall:

FF Issue the command Reset Stall.

HART Issue the command Reset Stall.

BCP un stall

To perform a Board Reset:

FF Issue the command Reset.

HART Issue the command Board Reset.

BCP reset

ALARM OUTPUT CONFIGURATION

An external alarm indication is available from a solid state relay on the DCM-3. This indication is a powered circuit, not a dry relay contact. Output voltage is either 120 Vac or 240 Vac, depending on the actuator power.

Depending on the model of actuator and on options that are installed, an optional electro-mechanical relay may be installed in the actuator. Check the wiring diagram that was attached to the actuator. The configuration information described here applies to the DCM-3 solid state alarm output circuit, not the optional electro-mechanical relay. The alarm output polarity can be configured as either energized or de-energized in the alarm condition. When line power is removed from the actuator, the relay is open regardless of the polarity setting.

The alarm output is typically available at terminal E, but the wiring diagram attached to the actuator should be referenced.

To set the desired alarm polarity:

FF Modify parameter Polarity.

HART Modify parameter AlarmPol.

BCP alarmout

A choice is also available as to what status situations create an external alarm indication. In FF and HART, make certain a check mark or "ON" is placed next to conditions that are desired as external alarms.

FF Modify parameters Mask 1 and Mask 2.

HART Modify parameter Alarm Mask.

BCP alarmoutmask

DCM-3 Configuration

Alarm Output Configuration, cont'd

Alarm	Analog HART (Refer to Page...)	Foundation Fieldbus (Refer to Page...)
Demand LOS	23	23
Torq/Thrust High	n/a	n/a
Stall	21	21
Torq/Thrust Stop	n/a	n/a
Stop/Limit	20	20
FeedbackLOS	29	29
Temperature	20	20
PositionLOS	26	26
RTC Fail	(1)	(1)
Torq/ThrustMeasFail	n/a	n/a
PositionA/D/ Error	(1)	(1)
DemandMeasFail	(1)	(1)
Reserved1		
TemperatureMeasFail	(1)	(1)
MemoryFail	(1)	(1)
InvalButtonPress		
DemandTooHigh		
Reserved 2		
Reserved 3		
Reserved 4		
Reserved 5		
Reserved 6		
Reserved 7		
Reserved 8		
Reserved 9		
DemUnderHART/FF Ctl	61	61
DemUnderPAT Ctl	61	
Reserved 10		
Reserved 11		
Reserved 12		
Reserved 13		

(1) These alarms indicate a DCM-3 failure.

DEMAND

Demand is the signal the DCM-3 uses to determine the desired position of the output shaft. Depending on the type of control system and corresponding model of DCM-3, the DCM-3 is designed to accept a digital Demand signal or an analog Demand signal. Foundation Fieldbus signals are digital. Analog systems with HART can use an analog signal or a digital signal. All DCM-3 models have test modes that can be used to temporarily override the control system signal. For more information on checking the source of the Demand signal, refer Operating Mode (page 15).

FF

Demand is written to the Beck actuator as CAS-IN of the Analog Output block. The typical scaling is 0% CAS-IN is 0% Demand, and 100% CAS-IN is 100% Demand. Refer to Foundation Fieldbus Communication Overview (page 11). The correct Demand Op Mode (page 23) is Hold. The scaling of 0% to 100% is passed through the Demand Characterizer. Therefore, if Linear is not chosen for the characterization, 50% Demand may not correspond to 50% output shaft position. Refer to DEMAND SIGNAL CHARACTERIZATION (page 23).

ANALOG/HART

For analog systems and HART compatible DCM-3's, Demand is usually an analog value between 4 mA and 20 mA. For the DCM-3 to properly interpret the Demand signal, the DCM-3 must know the appropriate Lower Range (0%) and Upper Range (100%) values of Demand.

Demand Lower Range and Upper Range values are set to the customer specification and tested at the Beck factory.

If using a HART system, the Demand Op Mode can be changed to allow the Demand to be assigned as a digital percent, similar to the FF method of assigning Demand. Refer to Operating Mode (page 23).

Analog values between 4 mA and 16mA can be assigned as 0%, and values between 8mA and 20 mA can be assigned as 100%. Note that the 0% value must be at least 4 mA less than the 100% value.

In analog systems, the term "split range" is occasionally used to describe more than one actuator working from the same Demand signal. A two-way split would be one actuator working from 4 mA to 12mA and the second actuator working from 12mA to 20 mA. If configuring for a two-way split range as described, the range values for one actuator would be 4 mA and 12mA, and for the other actuator 12mA and 20 mA.

To set the 0% signal level:

HART Modify parameter DemRngLwr

BCP dem0pctma

LOCAL Apply the desired 0% value then press and hold “CALIBRATE” and DEM 0% until the “ACKNOWLEDGE” LED lights. If the “DEMAND” LED lights, the signal is not within the acceptable range.

To set the 100% signal level:

HART Modify parameter DemRngLwr

BCP dem100pctma.

LOCAL Apply the desired 100% value then press and hold “CALIBRATE” and DEM 100% until the “ACKNOWLEDGE” LED lights. If the “DEMAND” LED lights, the signal is not within the acceptable range.

PARALLELSIGNALCONNECTIONS

Foundation Fieldbus devices are permitted to be connected in parallel for normal operation. Analog/HART devices can be connected in parallel with limitations as described in Parallel Connected Operation (page 13).

DEMAND SIGNAL CHARACTERIZATION

The DCM-3 can interpret the Demand as representing the desired output shaft position as a linear relationship or as a nonlinear relationship. The choices are Linear, Square, Square Root, and Special. Refer to SETTING DEMAND SIGNAL CHARACTERIZATION (page 23) for more details concerning each selection.

To choose the relationship:

FF Modify parameter Demand Curve.

HART Modify parameter Dem Curve.

BCP demfunc

LOSS OF DEMAND SIGNAL (L.O.S.)

If Demand is an analog signal, a possibility exists that the signal will drop below acceptable level and is considered invalid. This condition is called Demand L.O.S., and creates an alarm. The threshold for invoking the L.O.S. alarm is adjustable. DCM-3s are typically configured to stop the actuator during L.O.S. conditions. This is called L.O.S. Stay In Place. The DCM-3 can be configured to travel the output shaft to a predetermined position. This is called L.O.S. Go to Position. Under the L.O.S. condition, the STAT and DEMAND LEDs will light. When the input signal is corrected, the actuator will automatically resume normal operation.

The DCM-3 can be configured to suppress the alarm even if the Demand signal is below the alarm threshold. This is called L.O.S. PAT mode.

To set the threshold level:

HART Modify parameter DemLimLwr.

BCP demlos

To set the action on L.O.S.:

HART Modify parameter LOS Mode.

BCP demlos

To set the predetermined position to run to if in the L.O.S. condition:

HART Modify parameter LOS Pos.

BCP demlogtp

DEMAND OPERATING MODE

The Demand Op Mode can be changed to select a source of Demand signal other than the typical source.

The Demand Op Mode parameter can have the following values:

Follow: Follow the analog Demand signal. This mode is not available in Foundation Fieldbus systems. In analog/HART systems, this is the correct mode if an analog signal is being used as Demand.

Hold: Use the digital value transmitted by the Foundation Fieldbus or HART network. This is the correct mode for Foundation Fieldbus systems. In analog/HART systems, this mode can be used if the control system can write a digital value to the Demand parameter.

RunRET: Run the motor so the output shaft retracts until an over-travel limit is reached. This is a diagnostic mode that should only be used for closely controlled tests.

RunEXT: Run the motor so the output shaft extends until an over-travel limit is reached. This is a diagnostic mode that should only be used for closely controlled tests.

Stay: Run the motor to preserve present position. This mode is for special circumstances.

Stop: Remove power from the motor.

FF Modify parameter Op Mode.

Whenever the Transducer Block is placed in AUTO, Op Mode returns to Hold. Hold allows the actuator to accept the digital Demand signal from the control system.

HART Modify parameter Op Mode.

BCP opmode

When the DCM-3 is installed in a system using analog control, Demand Op Mode should be set to Follow.

DCM-3 Configuration

SETTING DEMAND SIGNAL CHARACTERIZATION

The DCM-3 incorporates a configurable Demand signal characterization feature. In addition to the standard linear response, there are three characterization curves available: a square function, a square root function, and a 20 segment custom characterizer. These options allow the user to set a non-linear response characteristic to compensate for non-linear final control elements.

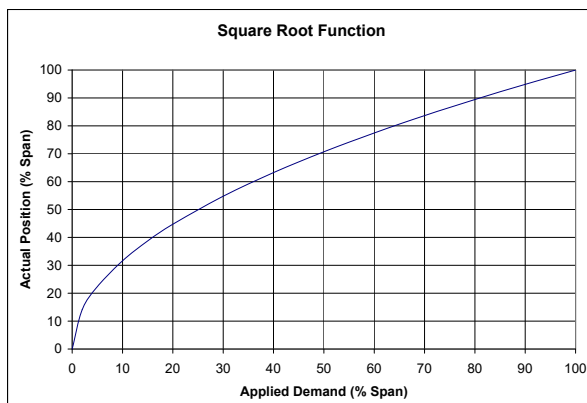
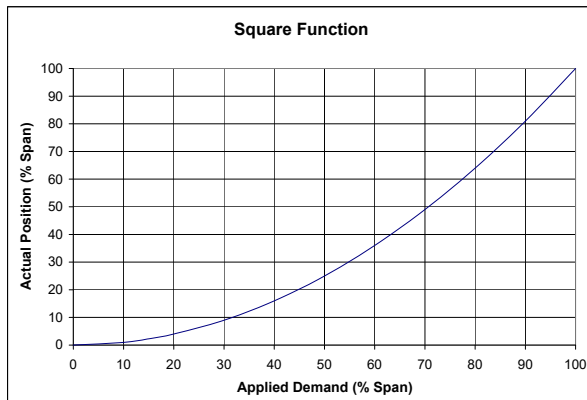
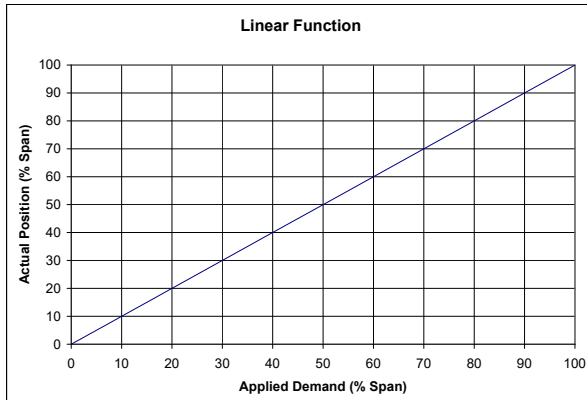

NOTE: Implementing a square root characterization creates extremely high gain when the Demand signal is below 10%. This causes instability and is unsuitable for control in this region. Do not apply this curve if the control loop may need to modulate at the lower range of valve/damper travel.

SPECIAL CURVE

The 20-segment characterizer allows the user to emulate any curve profile by using a series of straight lines. The straight lines are called segments.

Special curves do not have to use all 20 segments, but the used segments must be grouped together. Segments cannot be skipped.

Each segment is defined by a starting point and an ending point. The starting and ending points are called nodes. A node is an X,Y point such as can be plotted on rectangular grid graph paper.

Segment 1 starts at node 1 and ends at node 2. Segment 2 starts at node 2 and ends at node 3. Segment 20 starts at node 20 and ends at node 21.

Unless otherwise specified, the Special curve ships from the factory defined as a linear function. This definition is accomplished by defining only 1 of the possible 20 segments. By defining the first segment start point (node 1) as (X = 0%, Y = 0%) and the first segment end point (node 2) as (X = 100%, Y = 100%), all points between are calculated to be on a straight line. To implement a curve, more than one segment can be defined.

X-values are chosen to give a reasonable spacing in Y-values. Y-values are calculated from X-values using the desired formula, or are chosen from X-values picked from a table of data.

When defining nodes, X-values and Y-values must increase as the node number increases. For example, the X-value and Y-value of node 2 must be higher than the X-value and Y-value of node 1. Nodes cannot be skipped. Always start at node 1.

The following example implements a special curve that approximates a square function. Mathematically, a square function multiplies the Demand signal by itself, and uses the result as the desired output. In this situation, Y-values are calculated from X-values.

This example uses 5 segments to approximate the square curve. Segments 1 through 5 are needed, so nodes 1 through 6 are used.

Table 2 (left side) on page 27 describes the Y-value calculation to determine the proper Y-value after X-values were chosen. The right side of Table 2 is the condensed result. The result values are entered into the DCM-3.

Unused nodes are technically set to "infinity." Some Foundation Fieldbus and HART interfaces do not properly handle infinity, so a work around is to set the X-values and Y values to 1000%. Some interfaces do not properly display infinity, so the unused nodes may appear to have an unexpected value.

The first part of Table 2 below shows how the Y-value is calculated. The X-values are chosen as seems appropriate for this desired curve. The second part of Table 2 represents the resultant data. This resultant data must be entered into the DCM-3. The resultant function is shown plotted. The diamonds represent the nodes.

When entering values, enter the X-value and Y-value as a set, then send to the DCM-3. When increasing the number of nodes that are being used, start with node 1 and work to higher node numbers. When reducing the number of nodes that are being used, start with the highest node used and set that node to unused, and work back toward lower node numbers.

To enter the node values:

FF Modify parameter DemNode 1 through DemNode 21.

HART Modify parameters DemNode1X and DemNode1Y through DemNode21X and DemNode21Y.

BCP charset, charlist, charclear

**TABLE 2:
SPECIAL CURVE CALCULATIONS**

Node	X-value (Demand) % Span	Y-value (Position) Calculation	Desired Position
1	0%	0% x 0% => 0.00 x 0.00 => 0.00	0%
2	10%	10% x 10% => 0.10 x 0.10 => 0.01	1%
3	25%	25% x 25% => 0.25 x 0.25 => 0.06	6%
4	50%	50% x 50% => 0.50 x 0.50 => 0.25	25%
5	75%	70% x 70% => 0.70 x 0.70 => 0.49	49%
6	100%	100% x 100% => 1.00 x 1.00 => 1.00	100%

Node	X-value (Demand) % Span	Y-value (Position) % Span
1	0%	0%
2	10%	1%
3	25%	6%
4	50%	25%
5	75%	49%
6	100%	100%

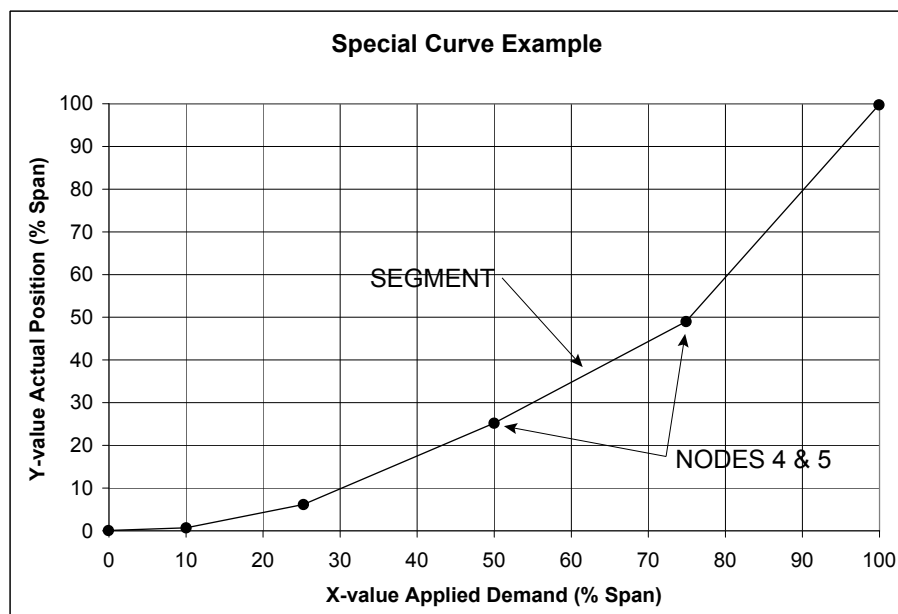

DCM-3 Configuration

OUTPUT SHAFT POSITION SENSING

Shaft position sensing is performed by the CPS-5 circuit board assembly. The DCM-3 must be configured to accept the appropriate signal range from the CPS-5. For more information on the CPS-5, refer to Control End Overview (page 32).

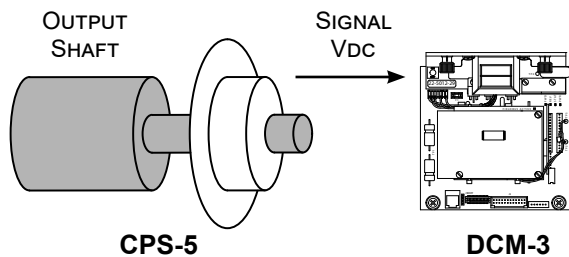

The standard signal range is 1 V to 5 V for 100 percent of output shaft travel.

If less than the maximum travel is desired, these voltages remain the correct values, but the stroke must be adjusted mechanically to reduce the travel range. See STROKE CHANGE—CALIBAR (page 35).

The maximum possible travel value is set in the DCM at the factory. It should not be changed from the default value for the Model 14. It can be viewed as follows:

FF Read parameter MaxTravel.

HART Read parameter MaxTravel.

BCP travelmax

If the Maximum travel is not correct, follow the procedure listed in Setting Model Defaults.

The DCM-3 expects the CPS-5 signal to increase from minimum voltage to maximum voltage as the output shaft retracts. Although the internal CPS-5 signal increases with retraction, either end of travel can be configured to be the 0% position. Refer to DIRECTION OF OUTPUT SHAFT TRAVEL (page 28).

To confirm the DCM-3 expects the CPS-5 signal to increase as the output shaft retracts:

FF Read parameter Snsr Dir.

HART Read parameter Snsr Dir.

BCP cpsrotation

If the direction is not retract for increasing signal, follow the procedure listed in Setting Model Defaults.

If the position sensing signal to the DCM-3 is below -5% or above 105% of the range given above, a POSITION alarm is generated. These values are known as the Position lower limit (PosLwrLim) and Position upper limit (PosUpLim). The limit values are not adjustable. This alarm does not affect actuator performance.

If the signal drops out of the range of 0.25 Vdc to 5.3 Vdc, the CPS-5 is considered invalid. A separate Position LOS alarm is generated. The DCM-3 will not try to run the motor. This alarm automatically clears if the CPS-5 signal becomes valid.

Both alarms light the STAT LED, and if the local configuration panel is available, light the POSITION LED.

To confirm the correct signal ranges:

FF Read parameter CPS RngLwr.

HART Read parameter CPS RngLwr.

BCP cpsvatposa
and

FF Read parameter CPS RngUp.

HART Read parameter CPS RngUp.

BCP cpsvatposb

If the signal ranges are not correct, follow the procedure listed in Setting Model Defaults.

Setting Model Defaults

Several parameter values are intended to be set based on the actuator model. These parameters should not be changed as part of routine configuration. If these parameters are not correct, they can be set by using a command instruction to have the DCM-3 update the values based on the actuator serial number (parameter Actuator S/N). The affected DCM-3 parameters are the direction of travel for an increasing CPS-5 signal, the expected range of CPS-5 signal, and the Maximum Travel. For information on the serial number format, refer to Serial Number (page 4).

Use the following procedure to install the correct values:

FF

1. Write parameter Actuator S/N. Make certain the parameter is written into the DCM-3.
2. Execute Reset Settings with the option Use Model Defaults.

HART

1. Write parameter Actuator S/N. Make certain the parameter is written into the DCM-3. If the HART host asks to use the default settings, agree.
2. If the host did not automatically use default settings, execute Use Default Setup.

BCP

1. Write the serial number with command: sernum
2. Execute command configformodel.

After choosing the appropriate maximum voltage range, the 0% point can be set through parameter CPS Zero%. See OUTPUT SHAFT 0% POSITION (page 28).

LOCAL

If a computer interface is not available, the position sensing voltage ranges can be set using the local configuration interface. Using the local interface performs two functions simultaneously. First, the voltage range end point is defined. Second, the voltage end point is automatically defined as 0% or 100%. The parameter Snsr Dir (page 26) cannot be modified without a computer, but should already be set correctly to Retract for an increasing signal. To use the local interface, use the procedure described under TRAVEL.

TRAVEL

The Travel parameter should not be changed from the factory default value for Model 14 actuators. The MaxTravel parameter and Travel parameter are factory set and should match.

If the 100% stroke travel needs to be modified for any reason (which would be unlikely since the Model 14 is usually factory set for a particular valve), the stroke adjustment should be made mechanically by adjusting the Calibar located under the main cover (see STROKE CHANGE—CALIBAR, page 35).

To match the desired travel distance:

FF Modify parameter Travel.

HART Modify parameter Travel.

BCP travel

LOCAL

1. Move the output shaft to the desired 0% position.
2. Press and hold "CALIBRATE" and POS 0% until the "ACKNOWLEDGE" LED lights.
3. Move the output shaft to the desired 100% position.
4. Press and hold "CALIBRATE" and POS 100% until the "ACKNOWLEDGE" LED lights.

If the "POSITION" LED lights, the signal is not within the acceptable range.

DCM-3 Configuration

OUTPUT SHAFT 0% POSITION

If desired, the DCM-3 can be configured for various 0% shaft positions. When changing the DCM-3 configuration, a limited amount of 0% adjustment is available. The total travel of the actuator output shaft is constrained by the mechanical stops inside the actuator body.

The parameter CPS Zero% can be modified to choose the exact 0% position. This parameter sets the CPS-5 voltage signal that the DCM-3 interprets as 0%. This parameter does not have to be changed in most installations: the travel distance is set with the Calibar and the 0% point can be set with the shaft coupling or crank arm.

To set the voltage associated with 0%:

FF Modify parameter CPS Zero%.

HART Modify parameter CPS Zero%.

BCP cpsvat0pct

LOCAL Set CPS Zero% using the POS 0% button. Refer to OUTPUT SHAFT POSITION SENSING (page 28).

The CPS Zero% parameter is automatically changed when the DIRECTION OF OUTPUT SHAFT TRAVEL (page 28) is changed. This is because what was the CPS-5 voltage at 100% becomes the CPS-5 voltage at 0%, and the voltage that was 0% becomes the voltage at 100%.

When changing CPS Zero% as part of reducing output shaft travel (page 28), reduce travel first using the Calibar, change the Travel parameters to match, then change CPS Zero%.

DIRECTION OF OUTPUT SHAFT TRAVEL (RETRACT vs. EXTEND)

Direction of output shaft travel is determined by observing the output shaft as shown in the illustration at right.

A very important aspect of direction of travel is whether the output shaft retracts or extends in reaction to an increasing Demand signal. The correlation between the Demand signal from the control system and the shaft movement can be selected as either RET increasing or EXT increasing.

With an actuator configured to retract with increasing Demand, the 0% endpoint will be at the extend end of travel. With an actuator configured to extend with increasing Demand, the 0% endpoint will be at the retract end of travel.

To set the proper direction:

FF Modify parameter Actuator Dir.

HART Modify parameter Actuator Dir.

BCP drvdir

If using the DCM-3 pushbuttons for configuration (not available with Foundation Fieldbus), the direction of rotation can be changed using any of the three following methods:

1. Press and hold the "CALIBRATE" pushbutton, then press the "DIR SEL" pushbutton until the (opposite) "DIRECTION" LED is lit.

OR

2. Move the output shaft to the desired 0% angular position.

Press and hold "CALIBRATE" and POS 0% until the "ACKNOWLEDGE" LED lights.

OR

3. Move the output shaft to the desired 100% angular position.

Press and hold "CALIBRATE" and POS 100% until the "ACKNOWLEDGE" LED lights.

If the "POSITION" LED lights, the signal is not within the acceptable range.

Changing the shaft direction for increasing Demand signals does not change the CPS-5 signal ranges. The CPS-5 output voltage always increases when the output shaft retracts. With RET increasing actuators, the CPS-5 signal is minimum at 0% and increases as the Demand increases. With EXT increasing actuators, the CPS-5 signal is largest at 0% and decreases as the Demand increases. The DCM-3 mathematically compensates for the CPS-5 signal direction so all signals remain correct for the chosen direction of rotation.

One of the changes the DCM-3 makes in response to changing the shaft direction for increasing signal is to automatically change the parameter CPS Zero% (page 28). This is necessary because the relative end points of CPS-5 signal swap when the shaft direction choice is changed.

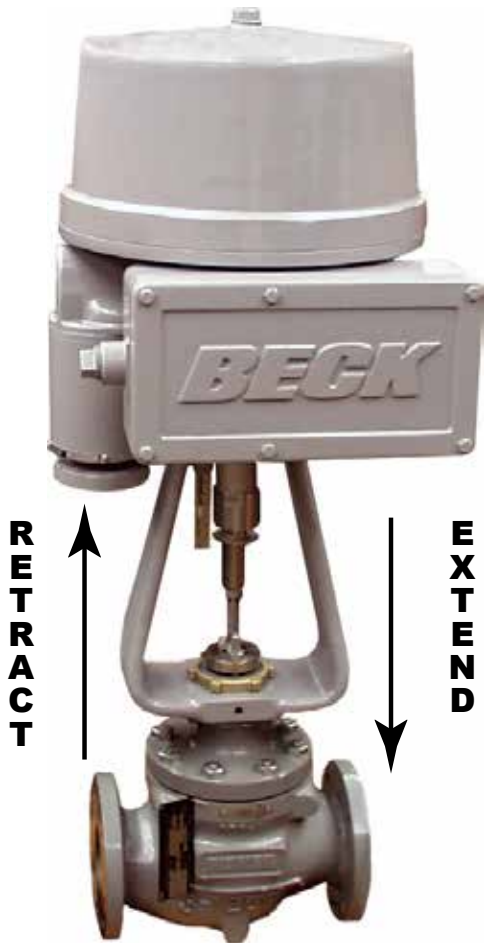

SHAFT DIRECTION REFERENCE

POSITION FEEDBACK SIGNAL

All DCM-3 circuit boards have the ability to inform the control system as to the actual position of the output shaft.

To read the actual position:

FF Read parameter Position or read PV in the Analog Output Block.

HART Read parameter Position.

BCP stat

HART equipped actuators have an analog position feedback signal available (typically 4–20 mA). This Feedback is available at the field wiring terminals (page 10). The ranging information that controls Feedback can be modified. See CONFIGURING FEEDBACK (page 29).

CONFIGURING FEEDBACK

The Feedback signal in analog systems is intended to be a 4 mA to 20 mA signal. Typically, 4 mA represents 0% shaft position, and 20 mA represents 100% shaft position.

This signal can be enabled or disabled. If the signal is enabled but the connection is left electrically open, a FDBK OPEN alarm condition is created. To eliminate the alarm, either close the electrical loop or disable the signal.

The enabling and disabling of the Feedback function takes the form of three options: nothing enabled, Feedback enabled, or potentiometer power enabled. The potentiometer power setting would be used if the actuator used a potentiometer in place of the CPS-5. This setting is for retrofit purposes and does not apply to the products described in this instruction manual.

To enable or disable the Feedback function:

HART Modify parameter Feedback in the Feedback Setup menu.

BCP iomode

DCM-3 Configuration

Feedback current representing 0% can be any-value between 3 mA and 16 mA. Feedback current representing 100% can be any-value between 8 mA and 21 mA. The current representing 100% must be at least 4 mA higher than the current representing 0%.

To set the current corresponding to 0%:

HART Modify parameter FB RngLwr.

BCP fdbk0pctma

To set the current corresponding to 100%:

HART Modify parameter FB RngUpr.

BCP fdbk100pctma

The relationship between the Feedback signal and the output shaft position is set to Linear unless otherwise specified. There are two choices: Linear, and Inverse Demand. The purpose of Inverse Demand is to allow a system to compare the Feedback signal to the Demand signal, even if the Demand signal is being used with characterization inside the DCM-3. For information on Demand characterization, refer to SETTING DEMAND SIGNAL CHARACTERIZATION (page 24).

For example, if the Demand is set to Square with a 4 mA to 20 mA range, then 12 mA Demand corresponds to 25% position. If Feedback is Linear with a range of 4 mA to 20 mA, then Feedback at 25% would be 8 mA. For some control systems, having the Demand at 12 mA and the Feedback at 8 mA is an issue. The Feedback characterization can be set to the inverse Demand curve so the Demand and Feedback match at signal balance. In this example, with Feedback set to Inverse Demand and the output shaft position at 25%, the Feedback signal would be 12 mA.

To choose Feedback characterization:

HART Modify parameter FB Curve.

BCP fdbkfunc

DCM-3 ANALOG SIGNAL CALIBRATION/TRIM

DCM-3 models that are configured to interface with analog control systems use analog/digital converters to handle the analog signals. These converters are high accuracy, low drift integrated circuits that are calibrated and tested at the Beck factory. Recalibration of these circuits should not be necessary.

DEMAND SENSING TRIM

If the DCM-3 model is intended to receive an analog Demand signal, the analog signal calibration can be adjusted. This is different than selecting the range as described in DEMAND (page 22). In that section, the choice of signal ranges was set. Calibration is intended to make certain that 4 mA is measured as 4 mA, and 20 mA is measured as 20 mA.

Analog Demand calibration does not apply to Foundation Fieldbus or installations using the local configuration interface. Foundation Fieldbus does not have an analog Demand signal. The local configuration interface uses whatever value is applied as Demand, and does not try to interpret the exact number of milliamps.

The technique for calibrating the analog Demand is to apply exactly 4 mA or 20 mA, then identify the value to the DCM-3.

To calibrate the analog Demand sensing at 4 mA, apply 4 mA, then:

HART Write 4 to parameter Loop(Dem) in the Calibration Trim menu.

BCP trimdem4 mA

To calibrate the analog Demand sensing at 20 mA, apply 20 mA, then:

HART Write 20 to parameter Loop(Dem) in the Calibration Trim menu.

BCP trimdem20 mA

FEEDBACK SOURCING TRIM

If the DCM-3 model is intended to transmit an analog Feedback signal, a digital-to-analog converter is used to generate the Feedback signal. Refer to SHAFT POSITION OUTPUT SIGNAL (page 26).

There is often confusion in the calibration of the Feedback signal. Situations can cause the appearance of an improperly trimmed Feedback signal, but as these examples show, the Feedback trim may not be the issue.

1. The output shaft is not at the desired angle, so the DCM-3 does not create the desired Feedback signal. In this situation, the output shaft should be moved to the correct position before changing Feedback settings.
2. The output shaft is at the desired angle, but the DCM-3 does not recognize the angle as being correct. In this situation, the DCM-3 position sensing configuration should be corrected.
3. An inaccurate measurement of the Feedback signal is being made. Check the Feedback current with an accurate meter at the actuator.

The examples mentioned here are responsible for almost all situations where the Feedback signal is thought to be trimmed improperly. The Feedback signal is trimmed and tested at the Beck factory.

The technique of trimming is comprised of having the DCM-3 output a theoretical 4 mA, then identifying to the DCM-3 the exact mA the control system is measuring. Then, have the DCM-3 output a theoretical 20 mA, and identify to the DCM-3 the exact mA measurement.

To get the DCM-3 to output a theoretical 4 mA signal, move the output shaft to the 0% position. The FB RngLwr parameter should be 4 mA for this trim procedure.

To trim the 4 mA output point:

HART Write measured value to parameter Feedback in the CALIBRATION TRIM menu.

BCP trimfdbk4 mA

To get the DCM-3 to output a theoretical 20 mA signal, move the output shaft to the 100% position. The FB RngUp parameter should be 20 mA for this trim procedure.

To trim the 20 mA output point:

HART Go to the CALIBRATION TRIM menu and enter the exact measured Feedback current into the Feedback parameter.

BCP trimfdbk20mA

CONTROL END

CONTROL END OVERVIEW

The control end contains the devices that monitor the angular position of the output shaft. The position measurement devices can be grouped into three categories.

1. An electronic sensor assembly, named the CPS-5, monitors the position and creates an electrical signal representing the exact shaft location.
2. Cam-operated switches act as internal over-travel limits. These switches act to block motor power when actuated.
3. Cam-operated switches provide open/closed-style position sensing for the external control system. These switches are called Auxiliary switches.
4. The Beck Calibar which can be used to adjust the total actuator stroke.

The CPS-5 is a rotary differential transformer capable of providing accurate output shaft position measurements over a range exceeding 100 degrees of output shaft movement. The signal created by the CPS-5 if connected to the DCM-3. Customer access to the signal is through the DCM-3.

Over-travel limit switches provide electrical limits for Handswitch operation and Automatic operation.

Auxiliary switches are wired to the field wiring terminals in the actuator terminal block compartment. These switches are typically connected to the external control system to be used as needed.

When the Calibar is used to adjust the actuator stroke, the switches and feedback device are simultaneously adjusted to maintain full input span.

CALIBRATION PRIORITY

Group 14 actuators are equipped with built-in mechanical stops. All output shaft movement must occur within these stops.

The over-travel limit switches are used to limit the electrical control range of the actuator. These switches are cam operated and are set slightly wider apart than the actuator's intended full range of electronic operation. With this range, the limit switch cams are each set inside the mechanical stops and are positioned to provide an electrical over-travel protection without opening in the normal operating range.

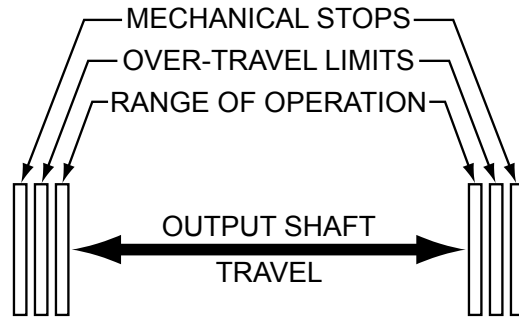

DEFAULT CALIBRATION RELATIONSHIP

When changing the settings for the over-travel limit switches, keep in mind that the switch operating points should be kept within the mechanical stops.

If changing the over-travel limit switch settings as part of a general recalibration, check the CPS-5 calibration before making any switch setting changes that could reduce the full range of output shaft travel.

Actuator stroke may be changed by adjusting the calibar (see page 35). The limit switches are simultaneously adjusted.

The auxiliary limit switches are also cam-operated, but have no affect on actuator and DCM-3 operation; therefore, they can be adjusted at any time without affecting performance or calibration.

BEFORE CHANGING THE CONTROL END

Proper control end calibration is important in all modes of actuator operation: Handswitch or Automatic. All Beck actuators are shipped completely calibrated and tested to the customer's specifications that were written into the equipment order. If the need arises to change the actuator calibration, first confirm that the actuator is installed as specified and operating properly before proceeding with the change. Nearly all routine configuration parameters are set in the DCM-3, which is not part of the control end. Before changing the control end, make certain desired changes are not intended to be set in the DCM-3.

CPS-5 CALIBRATION

The CPS-5 is a rotary differential transformer capable of providing accurate output shaft position measurements over a range exceeding 100% of output shaft movement. CPS-5 calibration does not change from model to model of Group 14 actuators, and calibration should not be changed as part of end-user configuration. End-user configuration changes are made in the DCM-3.

CPS-5 calibration is defined based on the 100% maximum output shaft travel range. The CPS-5 signal is approximately centered in the range between the actuator mechanical stops, and the CPS-5 signal range is 1.0 Vdc to 5.0 Vdc over 100% full range of travel.

All CPS-5's are calibrated and tested after being assembled into the actuator. Re-calibration should not be necessary.

If calibration is necessary, use the following technique:

1. Establish the center of travel between the mechanical stops.
2. Working from the center, establish the ends of 100% maximum travel.
3. Measure the CPS-5 output voltage at DCM-3 test points TP1(-) and TP4(+). Refer to DCM-3 Test Points and Resistor (page 80).
4. Adjust the CPS-5 calibration to achieve the correct signals at the ends of maximum rotation. To adjust the CPS-5 span, adjust trim potentiometer "SPAN". To adjust signal offset, shift the CPS-5 rotor position on the control shaft.
5. Make certain the CPS-5 output signal increases as the actuator output shaft retracts. Refer to DIRECTION OF OUTPUT SHAFT TRAVEL (page 28). If the output signal decreases as the actuator output shaft retracts, loosen the CPS-5 rotor, turn the rotor half a turn, and repeat the calibration procedure.

SWITCH CALIBRATION

NOTE: Your Beck actuator was shipped from the factory ready for installation; no electrical adjustments are required before placing it in operation. Each actuator is set up and calibrated to the customer's specifications that were written into the equipment order.

Under normal operating conditions there is no need to recalibrate the actuator. However, if the application requirements change or are different than specified on the equipment order, the actuator should be recalibrated according to the following procedures.

Switch Adjustments

All actuators are shipped with over-travel limit switches factory-set for 101% of travel unless otherwise specified at time of order. Limit switches must be set inside the range of the built-in mechanical stops to prevent stalling of the motor, but can be reset to limit travel of the output shaft. Optional auxiliary switches are set as shown below unless otherwise specified at time of order.

Switches are operated by cams which are clamped onto the control shaft. Setting a switch involves loosening the cam, moving the actuator's output shaft to the desired position, and positioning the cam so that it operates the switch at that point. In the following procedure, the use of a continuity meter is recommended to determine when the switch opens or closes. If such a meter is not available, it is possible to hear the switch click as the contacts open and close.



CAUTION

Do not attach the meter or attempt to move the switch cams until the actuator is disconnected from the line voltage and auxiliary switches are disconnected from external power sources.

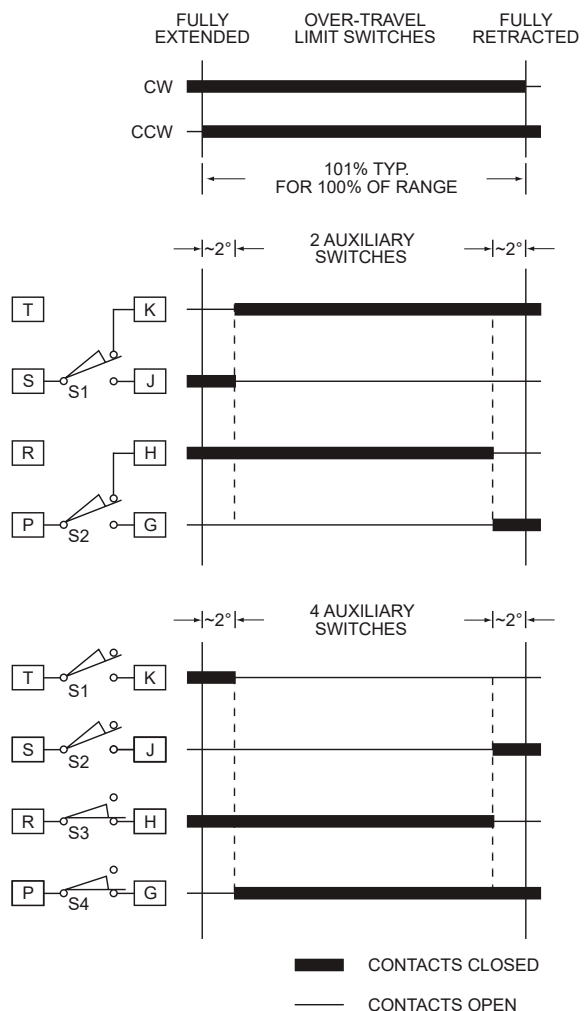

Standard Over-travel Limit and Auxiliary Switch Settings

CONTROL END

Setting Over-travel Limit Switches RET and EXT

This procedure should be used if the factory over-travel switch settings must be changed in the field. It is advisable to operate the actuator fully in each direction—using the electric Handswitch—to check switch settings before attempting to change them. Use the following instructions if they require adjustment:



Loosening/Tightening Switch Cam

1. Remove the top cover (15/16" bolt head). The O-ring seal will remain in the rim of the top cover when removed. Open the terminal block cover (1/2" bolt head).
2. Use the electric Handswitch to drive the control shaft so that the EXT switch cam is accessible. Using a 7/64" hex wrench, loosen the screw so that the cam is just snug to the shaft (see figure above).
3. Use the Handwheel to position the control shaft so that the lever of the sector-lever gear assembly is parallel with the upper bearing plate. See figure below for location of lever and bearing plate.



Lever and Bearing Plate

4. Disconnect power from the actuator.
5. Connect the continuity meter across terminals B and V. Rotate the cam until the meter shows no continuity (switch contact opens; switch clicks).
6. Tighten the cam locking screw to 5 lb-in (0.56 N•m) torque.
7. Disconnect the meter and reconnect switch wires and actuator power.
8. Using the Handswitch, drive the output shaft to the fully retracted position. Note the direction of rotation of the lobe of the cam. The correct cam lobe motion is away from the switch lever with the switch lever on the lower part of the cam. If this is not correct, return to step 2 and reset the cam to the proper orientation.
9. Drive the output shaft again to the fully extended travel limit. If the correct stopping point is reached (lever parallel with the upper bearing plate), the switch is properly set.
10. Manually position the control shaft position indicator dial to zero.
11. With the Handswitch, move the control shaft until the position indicator dial reaches the 150° position.
12. Repeat the instructions for setting the RET travel limit except that the direction of motion is opposite to that used for the EXT switch setting. Connect the continuity meter across terminals B and U.
13. Close the covers and tighten the terminal cover bolt to 10 lb-ft (13.5 N•m). Tighten the top cover bolt just enough to compress the O-ring seal.

Setting Auxiliary Switches

Standard switch settings for actuators with 2 or 4 auxiliary switches are shown on the diagram on page 33. The operating point of all auxiliary switches is defined as a percentage of output shaft travel. 100% is defined as the retracted limit of shaft travel. The heavy line indicates a closed circuit. Follow these instructions to change the operating point of auxiliary switches:

NOTE: In the following procedure, it is assumed that switch settings are to be adjusted so that contacts are open when the desired position is achieved. If they are to be adjusted to close, it may be necessary to reverse the operating mode of the switch by reversing the leads on the switch itself. Be sure to disconnect power from the switch terminals first.

1. Remove the top cover (15/16" bolt head). The O-ring seal will remain in the rim of the cover when removed. Open the terminal block cover (1/2" bolt heads).
2. Use the electric Handswitch to drive the shaft so that the switch cam is accessible. Using a 7/64" hex wrench, loosen the screw so that the cam is just snug on the shaft.
3. Move the output shaft to the desired position.
4. Disconnect power from the actuator.
5. Connect the continuity meter across the appropriate terminals. See the actuator wiring diagram or the chart on page 10. Rotate the cam until the meter shows no continuity (switch contacts open, switch clicks).
6. Tighten the cam locking screw to 5 lb-in (0.56 N•m) torque.
7. Disconnect the meter and reconnect power.
8. Move the actuator's output shaft in the desired direction so the cam lobe moves away from the switch lever. If not correct, return to step 2 and reset the cam to proper orientation.
9. Reconnect the meter.
10. Move the output shaft again toward the desired switch position. If the contacts open, the switch is properly set.
11. Close covers and tighten the terminal cover bolts to 10 lb-ft (13.5 N•m) torque. Tighten the top cover just enough to compress the O-ring seal.

5. Use the Handswitch to operate the actuator and check the stroke on the travel index of the valve yoke.
6. Replace the top cover after making adjustments. Tighten the top cover just enough to compress the O-ring seal.

NOTE: The limit switches and feedback device are adjusted automatically when the Calibar setting is changed. Do not adjust the limit switch cams to change the stroke travel. It is desirable, however, to calibrate the DCM-3 position reference to match the Calibar setting. See TRAVEL, page 27.

STROKE AND SPAN ADJUSTMENTS

The Calibar adjustment is designed to allow field changes of the total stroke travel corresponding to a 0–100% applied input signal.



Calibar Block

STROKE CHANGE—CALIBAR

Adjustment of the total stroke travel within the factory-set travel range is easily accomplished by the use of the Beck Calibar (see photo on this page). The switches and feedback device are simultaneously adjusted to maintain full input span when the Calibar setting is changed. For stroke lengths longer than factory-set travel limits material modifications are necessary—consult the factory.

Adjust stroke as follows:

1. Remove the top cover. The protective O-ring seal will remain in the rim of the top cover when removed.
2. The Calibar index is graduated directly in inches, which corresponds to the travel span.
3. Loosen the two locking screws on the Calibar block with an 1/8" hex wrench (See photo this page).
4. Slide the Calibar block, aligning the notch with the desired travel span on the Calibar index. Tighten the set screws.

DCM-3 HART Menus

HART MENUS AND DATA

Menu data included in the DD file defines a logical grouping of data and commands. The grouping uses a “tree” technique, with a root menu that branches into submenus. The root menu, by convention, is called “Online.”

HART hosts may use techniques other than the menu tree system to display information. This instruction manual is based on the menu tree system included in the DD.

Menus can contain read/write parameters, read-only parameters, commands, and other menus.

When writing to a parameter, make certain the data is transferred to the field device and not just recorded in the host. Most hosts have a technique to “send” the data.

When reading a parameter, make certain the data is up-to-date. The DD provides information to the host on how often data should be updated, but the host has the responsibility of actually updating the data.

Commands typically tell the host to change states, and may or may not change parameter data. For example, a HART command can cause the DCM-3 to go through a power-up reset cycle, but that doesn’t necessarily change any parameter data.

The same parameters can appear on multiple menus, and the read/write permission can be different on different menus. The labels used to display parameters can be used for multiple purposes. For example, the label Feedback is used in the Feedback Setup menu to identify if the Feedback function is enabled, and is used in the Online menu to identify the current signal.

Some data items only appear in appropriate circumstances, such as when corresponding hardware is installed in the field device.

MENU TREE

The menu tree to the right is defined in the DD for the DCM-3, but the display is host-dependent. Values shown for various parameters are hypothetical, actual values will differ. Some of the parameters shown in the menus are product configuration dependent; these parameters may not show in some applications.

A cross reference of parameter label to menu block can be found on page 44.

Online Menu (Block 1)

The first line of the Online menu is a link to the remainder of the menu tree. The other lines are the values of the process related parameters.

- 1 Function:** The link to the remainder of the menu tree.
- 2 Position:** The output shaft position displayed as percent of range. The range is selected with travel and 0% settings. (OUTPUT SHAFT POSITION SENSING, page 26)
- 3 Demand:** The Demand signal displayed as percent of range. The range is selected by 0% and 100% values. (DEMAND, page 23)
- 4 Loop(Dem):** The milliamp signal from the customer wiring terminals measured at the DCM-3.
- 5 Trq/Thrust:** Not active for the Group 14.
- 6 Temp:** the ambient temperature of the DCM-3. (TEMPERATURE SENSING, page 20)
- 7 Feedback:** The milliamp output signal representing the present position of the output shaft. (SHAFT POSITION OUTPUT SIGNAL, page 29)

Function Menu (Block 2)

This menu allows branching out to the remainder of the menus.

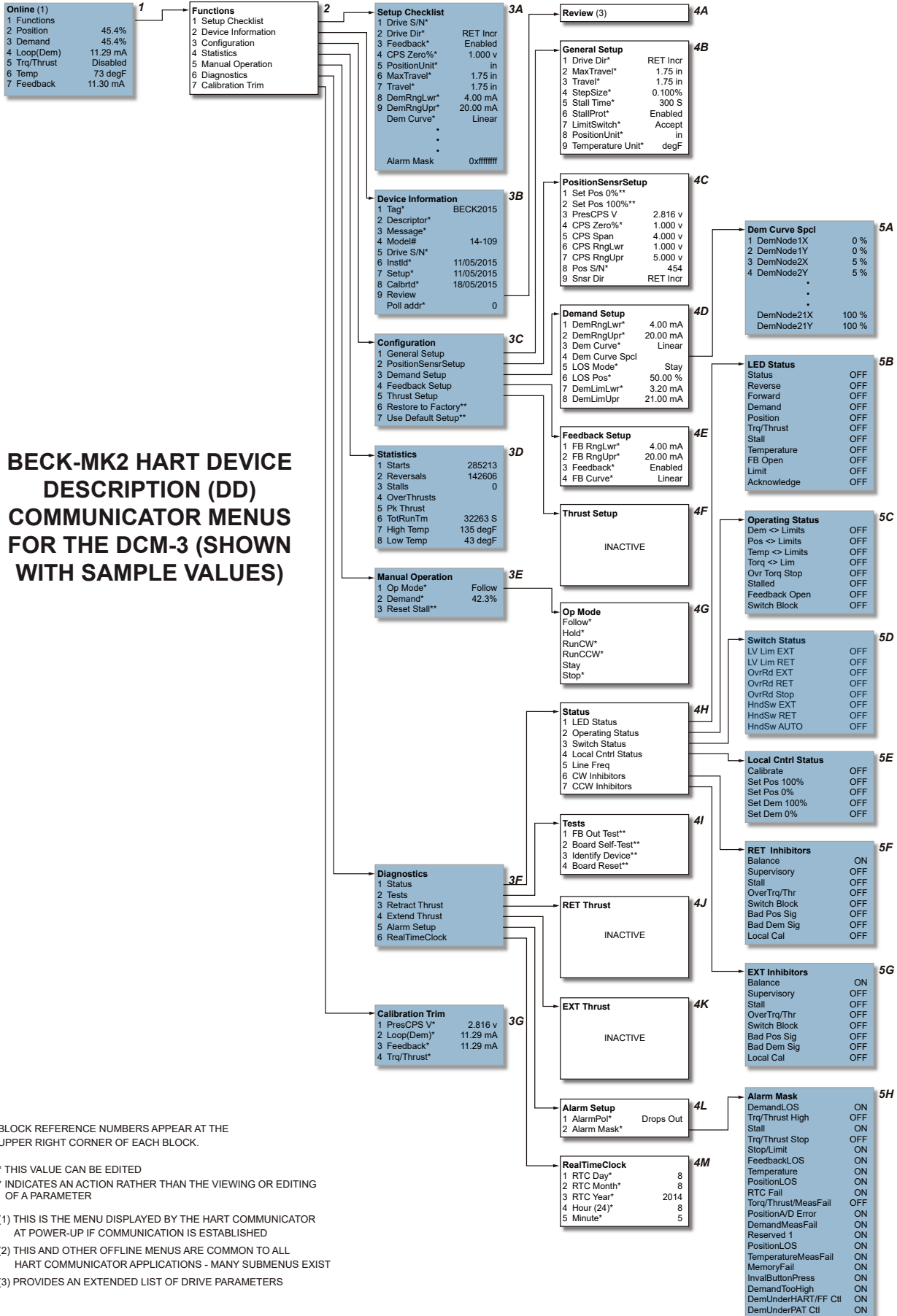

BLOCK REFERENCE NUMBERS APPEAR AT THE UPPER RIGHT CORNER OF EACH BLOCK.

* THIS VALUE CAN BE EDITED

** INDICATES AN ACTION RATHER THAN THE VIEWING OR EDITING OF A PARAMETER

- (1) THIS IS THE MENU DISPLAYED BY THE HART COMMUNICATOR AT POWER-UP IF COMMUNICATION IS ESTABLISHED
- (2) THIS AND OTHER OFFLINE MENUS ARE COMMON TO ALL HART COMMUNICATOR APPLICATIONS - MANY SUBMENUS EXIST
- (3) PROVIDES AN EXTENDED LIST OF DRIVE PARAMETERS

DCM-3 HART Menus

Setup Checklist Menu (Block 3)

This is a summary of the parameters a technician will want to make certain are correct for installing an actuator. Most of these parameters also appear elsewhere in the menu tree, and are gathered here for convenience.

- 1 **Actuator S/N:** The serial number as shown on the actuator nameplate. (Serial Number, page 4)
- 2 **Actuator Dir:** The direction the output shaft moves in response to an increasing Demand signal. (DIRECTION OF OUTPUT SHAFT TRAVEL, page 28)
- 3 **Feedback:** Determines whether the analog output signal representing the output shaft position is enabled. (SHAFT POSITION OUTPUT SIGNAL, page 29)
- 4 **CPS Zero%:** This is the voltage from the CPS-5 to the DCM-3 that the DCM-3 will interpret as 0% output shaft position (OUTPUT SHAFT 0% POSITION, page 28)
- 5 **PositionUnit:** For Group 14 this is inches.
- 6 **MaxTravel:** The maximum output shaft travel for this model of actuator. (OUTPUT SHAFT POSITION SENSING, page 26)
- 7 **Travel:** Amount of output shaft movement for 100% signal change. (TRAVEL, page 27)
- 8 **DemRngLwr:** Signal strength representing 0% Demand. (DEMAND, page 23)
- 9 **DemRngUpr:** Signal strength representing 100% Demand. (DEMAND, page 23)
- 10 **Dem Curve:** Whether Demand is interpreted as linear or a curve. (DEMAND SIGNAL CHARACTERIZATION, page 24)
- 11 **DemLimLwr:** Below this level, the Demand signal is considered invalid. (LOSS OF DEMAND SIGNAL (L.O.S.), page 23)
- 12 **LOS Mode:** Action on loss of demand signal. (LOSS OF DEMAND SIGNAL (L.O.S.), page 23)
- 13 **LOS Pos:** Substitute Demand signal under some LOS modes. (LOSS OF DEMAND SIGNAL (L.O.S.), page 23)
- 14 **FB RngLwr:** Signal strength used to represent 0% shaft position. (CONFIGURING FEEDBACK, page 29)
- 15 **FB RngUpr:** Signal strength used to represent 100% shaft position. (CONFIGURING FEEDBACK, page 29)
- 16 **FB Curve:** Whether the Feedback signal is transmitted as linear or a curve. (CONFIGURING FEEDBACK, page 29)
- 17 **Trq/Thrust:** Inactive for Group 14.
- 18 **Thr Null:** Inactive for Group 14.
- 19 **Thr Const:** Inactive for Group 14.
- 20 **AlarmLevel:** Inactive for Group 14.
- 21 **Ovt Prot:** Inactive for Group 14.
- 22 **ShutDwnThr:** Inactive for Group 14.
- 23 **StallProt:** Whether actuator motor will be turned off if the Stall Time counter expires. (STALL PROTECTION, page 21)
- 24 **Stall Time:** The amount of time the motor will run before Stall Protection is initiated. (STALL PROTECTION, page 21)
- 25 **Temperature Unit:** Unit of measure for temperature sensing. (TEMPERATURE SENSING, page 20)
- 26 **StepSize:** The typical smallest Demand change that will cause an output shaft movement. (STEP SIZE, page 22)
- 27 **LimitSwitch:** Modifies the behavior of Stop/Limit alarm. (STOP/LIMIT INDICATION, page 22)
- 28 **AlarmPol:** Whether the solid state relay opens on alarm or closes on alarm. (ALARM OUTPUT CONFIGURATION, page 21)
- 29 **Alarm Mask:** Which alarms cause the solid state relay to change state. (ALARM OUTPUT CONFIGURATION, page 21)

Device Information Menu (Block 4)

The Device Information menu is primarily documentation information.

- 1 **Tag:** Label used by the HART system to identify the specific field device. Tag does not affect actuator operation. Tag can be written by the HART network
- 2 **Descriptor:** A text field required by the HART system, but with no formal HART definition on a use. Descriptor does not affect actuator operation. Descriptor can be written by the HART network
- 3 **Message:** A text field required by the HART system, but with no formal HART definition on a use. Message does not affect actuator operation. Message can be written by the HART network
- 4 **Model#:** A field that is created within the DCM-3 by examining Actuator S/N. If this field does not match the model of actuator, change Actuator S/N
- 5 **Actuator S/N:** The serial number as shown on the actuator nameplate. (Serial Number, page 4)
- 6 **InstId:** The installation date. This is entered by a technician, and has not affect on actuator operation
- 7 **Setup:** The setup date has no affect on actuator operation
- 8 **Calbrtd:** The calibration date has no affect on actuator operation
- 9 **Review:** Link to the Review menu
- 10 **Poll addr:** HART uses this address to find the actuator. (Parallel Connected Operation, page 13)

Configuration Menu (Block 5)

This menu provides links to menus that contain common application-specific parameters, and contains two commands to use factory-defined configurations.

- 1 **General Setup:** Link to General Setup menu
- 2 **PositionSensrSetup:** Link to PositionSensrSetup menu
- 3 **Demand Setup:** Link to Demand Setup menu
- 4 **Feedback Setup:** Link to Feedback Setup menu

- 5 **Thrust Setup:** Inactive for Group 14
- 6 **Restore to Factory:** Allows the technician to restore all field configurable parameters back to the settings in effect when the DCM-3 was shipped from the factory. (Restore Factory Configuration, page 20)
- 7 **Use Default Setup:** Allows a technician to change the DCM-3 position sensing voltage ranges to the proper ranges for the actuator model. (OUTPUT SHAFT POSITION SENSING, page 26)

Statistics Menu (Block 6)

The Statistics menu allows a technician to gauge workload and operating conditions of the actuator.

- 1 **Starts:** The total number of motor starts.
- 2 **Reversals:** The total number of times the motor has started in the direction opposite to the previous start.
- 3 **Stalls:** The total number of times the stall timer has timed out. (STALL PROTECTION, page 21)
- 4 **OverThrusts:** Inactive for Group 14.
- 5 **Pk Thrust:** Inactive for Group 14.
- 6 **TotRunTm:** Total amount of time the motor has been powered.
- 7 **High Temp:** Highest temperature recorded in the DCM-3 compartment. (TEMPERATURE SENSING, page 20)
- 8 **Low Temp:** Lowest temperature recorded in the DCM-3 compartment. (TEMPERATURE SENSING, page 20)

DCM-3 HART Menus

Manual Operation Menu (Block 7)

The Manual Operation menu provides for controlling the actuator with digital data carried on the HART interface. It includes a command to reset the Stall function.

- 1 **Op Mode:** Determines whether DCM-3 should use the analog Demand signal or a digital signal as the source for actuator control. (Op Mode parameter, page 23)
- 2 **Demand:** This displays the Demand when Op Mode is Follow, or sets the Demand when Op Mode is Hold.
- 3 **Reset Stall:** A method for resetting the Stall alarm. (STALL PROTECTION, page 21)

Diagnostics Menu (Block 8)

This menu includes paths to menus that allow investigation of actuator problems, access to self-test routines, detailed output shaft loading history, and alarm output relay setup.

Calibration Trim Menu (Block 9)

The Calibration Trim menu lists parameters that are dependent on signal interface circuits. The circuits can be adjusted for accuracy through this menu. Changing the calibration trim can cause signal measurement difficulties if improper trimming is performed.

- 1 **PresCPS V:** Displays and/or trims the DCM-3 voltage sensing of the CPS-5 shaft position signal as measured at DCM-3 test points TP1(-) and TP4(+) (refer to page 80). This trim is set and tested at the factory. Changing this trim can cause voltage measurement errors.
- 2 **Loop(Dem):** Displays and/or trims the DCM-3 Demand sensing circuit. (DCM-3 ANALOG SIGNAL CALIBRATION/TRIM, page 31)
- 3 **Feedback:** Displays and/or trims the DCM-3 Feedback current sourcing circuit. (DCM-3 ANALOG SIGNAL CALIBRATION/TRIM, page 31)
- 4 **Trq/Thrust:** This is not active for the Group 14.

Review Menu (Block 10)

The Review menu allows a technician to view a large number of parameters in a summary format. In compliance with HART Communication Foundation recommendations, parameters cannot be edited in the Review menu.

General Setup Menu (Block 11)

The General Setup menu contains parameters that determine the overall actuator performance.

- 1 **Actuator Dir:** The direction the output shaft moves in response to an increasing Demand signal. (DIRECTION OF OUTPUT SHAFT TRAVEL, page 28)
- 2 **MaxTravel:** The maximum output shaft travel for this model of actuator. (OUTPUT SHAFT POSITION SENSING, page 26)
- 3 **Travel:** Amount of output shaft travel for 100% signal change. (TRAVEL, page 27)
- 4 **StepSize:** The typical smallest Demand change that will cause an output shaft movement. (STEP SIZE, page 20)
- 5 **Stall Time:** The amount of time the motor will run before Stall Protection is initiated. (STALL PROTECTION, page 21)
- 6 **StallProt:** Whether actuator motor will be turned off if the Stall Time counter expires. (STALL PROTECTION, page 21)
- 7 **LimitSwitch:** Modifies the behavior of Stop/Limit alarm. (STOP/LIMIT INDICATION, page 20)
- 8 **PositionUnit:** for Group 14 this is inches.
- 9 **Temperature Unit:** Unit of measure for temperature sensing. (TEMPERATURE SENSING, page 20)

PositionSensrSetup Menu (Block 12)

This menu contains parameters that determine how the DCM-3 interprets the output shaft position signal from the CPS-5.

- 1 **Set Pos 0%:** Instructs the DCM-3 to change the 0% position to match the present output shaft position. This does not change Travel. (OUTPUT SHAFT 0% POSITION, page 28)
- 2 **Set Pos 100% Span:** Instructs the DCM-3 to change Travel so the present output shaft position is 100%. This does not change the 0% position. (TRAVEL, page 27)
- 3 **PresCPS V:** Displays the output shaft position voltage signal at the DCM-3 from the CPS-5. (OUTPUT SHAFT POSITION SENSING, page 26)
- 4 **CPS Zero%:** This is the voltage from the CPS-5 to the DCM-3 that the DCM-3 will interpret as 0% output shaft position (OUTPUT SHAFT 0% POSITION, page 28)
- 5 **CPS Span:** The voltage span from the CPS-5 for the maximum travel of the output shaft. This is simply the upper range voltage minus the lower range voltage. (OUTPUT SHAFT POSITION SENSING, page 26)
- 6 **CPS RngLwr:** The CPS-5 voltage signal corresponding to the extend end of travel when Travel is set to the maximum rotation.
- 7 **CPS RngUpr:** The CPS-5 voltage signal corresponding to the retract end of travel when Travel is set to the maximum rotation
- 8 **Pos S/N:** A sequential number up to approximately 16 million that indicates the serial number of the CPS-5. Using this field is optional.
- 9 **Snsr Dir:** The direction of output shaft travel that causes the CPS-5 signal to increase. Except in some custom configurations, this direction should always be retract.

Demand Setup Menu (Block 13)

The parameters on this menu determine the signal range and the characterization of the Demand. It includes the parameters that determine behavior when the Demand signal is absent.

- 1 **DemRngLwr:** Signal strength representing 0% Demand. (DEMAND, page 22)
- 2 **DemRngUpr:** Signal strength representing 100% Demand. (DEMAND, page 22)

- 3 **Dem Curve:** Whether Demand is interpreted as linear or a curve. (DEMAND SIGNAL CHARACTERIZATION, page 24)
- 4 **Dem Curve Spcl:** Link to the Dem Curve Spcl menu
- 5 **LOS Mode:** Action on loss of demand signal. (LOSS OF DEMAND SIGNAL (L.O.S.), page 23)
- 6 **LOS Pos:** Substitute Demand signal under some LOS modes. (LOSS OF DEMAND SIGNAL (L.O.S.)
- 7 **DemLimLwr:** Below this level, the Demand signal is considered invalid. (LOSS OF DEMAND SIGNAL (L.O.S.), page 23)
- 8 **DemLimUpr:** Above this level, the Demand signal is considered invalid. The Demand alarm will be asserted until the signal is brought below this level

Feedback Setup Menu (Block 14)

Feedback Setup menu parameters that control the enable/disable state of the DCM-3 Feedback signal that represents the output shaft position, and the parameters that control the scaling.

- 1 **FB RngLwr:** Signal strength used to represent 0% shaft position. (CONFIGURING FEEDBACK, page 29)
- 2 **FB RngUpr:** Signal strength used to represent 100% shaft position. (CONFIGURING FEEDBACK, page 29)
- 3 **Feedback:** Determines whether the analog output signal representing the output shaft position is enabled. (SHAFT POSITION OUTPUT SIGNAL, page 29)
- 4 **FB Curve:** Whether the Feedback signal is transmitted as linear or a curve. (CONFIGURING FEEDBACK, page 29)

DCM-3 HART Menus

Thrust Setup Menu (Block 15)

Inactive for Group 14.

Status Menu (Block 16)

This menu provides a path to parameters that monitor the operational status of the actuator. It also includes the display of one parameter.

- 5 **Line Freq:** The power line frequency as measured by the DCM-3

Tests Menu (Block 17)

The Tests menu provides access to some routines that help determine if the actuator is running properly.

- 1 **FB Out Test:** Allows a technician to manually vary the Feedback output signal to check operation and accuracy. (SHAFT POSITION OUTPUT SIGNAL, page 29)
- 2 **Board Self-Test:** Instructs the DCM-3 to check various power and sensing circuits. This test should not be run unless sudden output shaft movements are allowable
- 3 **Identify Device:** Sends a HART command to the DCM-3 that causes the ACKNOWLEDGE LED to flash. This is to make certain the HART system is addressing the correct actuator
- 4 **Board Reset:** Causes the DCM-3 to go through a reset cycle similar to a power-up reset. This test should not be run unless sudden output shaft movements are allowable

Retract Thrust Menu (Block 18)

Inactive for Group 14.

Extend Thrust Menu (Block 19)

Inactive for Group 14.

Alarm Setup Menu (Block 20)

The Alarm Setup menu parameters allow modification of the behavior of the alarm output solid state relay.

- 1 **AlarmPol:** Whether the solid state relay opens on alarm or closes on alarm. (ALARM OUTPUT CONFIGURATION, page 21)
- 2 **Alarm Mask:** Which alarms cause the solid state relay to change state. (ALARM OUTPUT CONFIGURATION, page 21)

Real Time Clock Menu (Block 21)

The Real Time Clock menu allows setting of the real time clock inside the DCM-3. The real time clock does not influence actuator performance.

- 1 RTC Day: Day of the month (numeric value)
- 2 RTC Month: Month (numeric value)
- 3 RTC Year: Year (4 digits)
- 4 Hour (24): Hour of the day (24 hour format)
- 5 Minute: Minute of the hour (0 through 59)

Dem Curve Spcl Menu (Block 22)

This menu allows setting the Demand characterization nodes. (SETTING DEMAND SIGNAL CHARACTERIZATION, page 23)

LED Status Parameter (Block 23)

The LED Status parameter allows remote checking of which LED's on the DCM-3 are illuminated.

Operating Status Parameter (Block 24)

The Operating Status parameter is a summary of whether process-related conditions are inside or outside of anticipated limits. These conditions control the STATUS INDICATION LEDs (page 19).

- 1 **Demand:** Typically caused by the Demand signal falling below acceptable levels. (LOSS OF DEMAND SIGNAL (L.O.S.), page 23)
- 2 **Position:** Caused by the CPS-5 signal being outside the range anticipated by the DCM-3. (OUTPUT SHAFT POSITION SENSING, page 26)
- 3 **Temperature:** The ambient temperature of the DCM-3 is outside of the rating. (TEMPERATURE SENSING, page 20)
- 4 **Thrust:** Inactive for Group 14.
- 5 **Over-Thrust Stop:** Inactive for Group 14.
- 6 **Stalled:** A Stall alarm is active. (STALL PROTECTION, page 21)
- 7 **Feedback Open:** The Feedback signal is enabled, but cannot flow the proper current. (CONFIGURING FEEDBACK, page 29)

- 8 **Switch Block:** The DCM-3 cannot power the motor due to an electro-mechanical switch. Check the Handswitch and over-travel limit switches.

Switch Status Parameter (Block 25)

This parameter indicates which switches are being actuated. Group 14 actuators do not use this parameter.

Local Cntrl Status Parameter (Block 26)

This parameter allows remote monitoring of which buttons on the local configuration interface are being pressed. (PUSHBUTTON CONTROLS, page 18)

RET Inhibitors Parameter (Block 27)

This parameter allows a technician to view exactly what DCM-3 condition is preventing the actuator motor from running in the retract direction. Refer to Inhibitors Table (page 67).

EXT Inhibitors Parameter (Block 28)

This parameter allows a technician to view exactly what DCM-3 condition is preventing the actuator motor from running in the extend direction. Refer to Inhibitors Table (page 67).

Alarm Mask Parameter (Block 29)

Alarm Mask parameter shows which alarms will cause the alarm out solid state relay to activate. (ALARM OUTPUT CONFIGURATION, page 21)

DCM-3 HART Menus

HART Parameter Cross Reference

Menu Block Ref	Parameter Label	Menu Label
3	Alarm Mask	Setup Checklist
20	Alarm Mask	Alarm Setup
8	Alarm Setup	Diagnostics
3	AlarmLevel	Setup Checklist
15	AlarmLevel	Thrust Setup
3	AlarmPol	Setup Checklist
20	AlarmPol	Alarm Setup
17	Board Reset	Tests
17	Board Self-Test	Tests
4	Calbrtd	Device Information
2	Calibration Trim	Functions
16	EXT Inhibitors	Status
8	EXT Thrust	Diagnostics
2	Configuration	Functions
12	CPS RngLwr	PositionSensrSetup
12	CPS RngUpr	PositionSensrSetup
12	CPS Span	PositionSensrSetup
3	CPS Zero%	Setup Checklist
12	CPS Zero%	PositionSensrSetup
16	RET Inhibitors	Status
8	RET Thrust	Diagnostics
3	Dem Curve	Setup Checklist
13	Dem Curve	Demand Setup
13	Dem Curve Spcl	Demand Setup
1	Demand	Online
7	Demand	Manual Operation
5	Demand Setup	Configuration
3	DemLimLwr	Setup Checklist
13	DemLimLwr	Demand Setup
13	DemLimUpr	Demand Setup
22	DemNode10X	Dem Curve Spcl
22	DemNode10Y	Dem Curve Spcl
22	DemNode11X	Dem Curve Spcl
22	DemNode11Y	Dem Curve Spcl
22	DemNode12X	Dem Curve Spcl
22	DemNode12Y	Dem Curve Spcl
22	DemNode13X	Dem Curve Spcl
22	DemNode13Y	Dem Curve Spcl
22	DemNode14X	Dem Curve Spcl
22	DemNode14Y	Dem Curve Spcl
22	DemNode15X	Dem Curve Spcl
22	DemNode15Y	Dem Curve Spcl
22	DemNode16X	Dem Curve Spcl
22	DemNode16Y	Dem Curve Spcl
22	DemNode17X	Dem Curve Spcl
22	DemNode17Y	Dem Curve Spcl
22	DemNode18X	Dem Curve Spcl
22	DemNode18Y	Dem Curve Spcl

22	DemNode19X	Dem Curve Spcl
22	DemNode19Y	Dem Curve Spcl
22	DemNode1X	Dem Curve Spcl
22	DemNode1Y	Dem Curve Spcl
22	DemNode20X	Dem Curve Spcl
22	DemNode20Y	Dem Curve Spcl
22	DemNode21X	Dem Curve Spcl
22	DemNode21Y	Dem Curve Spcl
22	DemNode2X	Dem Curve Spcl
22	DemNode2Y	Dem Curve Spcl
22	DemNode3X	Dem Curve Spcl
22	DemNode3Y	Dem Curve Spcl
22	DemNode4X	Dem Curve Spcl
22	DemNode4Y	Dem Curve Spcl
22	DemNode5X	Dem Curve Spcl
22	DemNode5Y	Dem Curve Spcl
22	DemNode6X	Dem Curve Spcl
22	DemNode6Y	Dem Curve Spcl
22	DemNode7X	Dem Curve Spcl
22	DemNode7Y	Dem Curve Spcl
22	DemNode8X	Dem Curve Spcl
22	DemNode8Y	Dem Curve Spcl
22	DemNode9X	Dem Curve Spcl
22	DemNode9Y	Dem Curve Spcl
3	DemRngLwr	Setup Checklist
13	DemRngLwr	Demand Setup
3	DemRngUpr	Setup Checklist
13	DemRngUpr	Demand Setup
4	Descriptor	Device Information
2	Device Information	Functions
2	Diagnostics	Functions
3	Drive Dir	Setup Checklist
11	Drive Dir	General Setup
3	Drive S/N	Setup Checklist
4	Drive S/N	Device Information
3	FB Curve	Setup Checklist
14	FB Curve	Feedback Setup
17	FB Out Test	Tests
3	FB RngLwr	Setup Checklist
14	FB RngLwr	Feedback Setup
3	FB RngUpr	Setup Checklist
14	FB RngUpr	Feedback Setup
1	Feedback	Online
3	Feedback	Setup Checklist
9	Feedback	Calibration Trim
14	Feedback	Feedback Setup
5	Feedback Setup	Configuration
1	Functions	Online
5	General Setup	Configuration
6	High Temp	Statistics

21	Hour (24)	RealTimeClock
17	Identify Device	Tests
4	InstId	Device Information
16	LED Status	Status
3	LimitSwitch	Setup Checklist
11	LimitSwitch	General Setup
16	Line Freq	Status
16	Local Cntrl Status	Status
1	Loop(Dem)	Online
9	Loop(Dem)	Calibration Trim
3	LOS Mode	Setup Checklist
13	LOS Mode	Demand Setup
3	LOS Pos	Setup Checklist
13	LOS Pos	Demand Setup
6	Low Temp	Statistics
2	Manual Operation	Functions
3	MaxTravel	Setup Checklist
11	MaxTravel	General Setup
4	Message	Device Information
21	Minute	RealTimeClock
4	Model#	Device Information
7	Op Mode	Manual Operation
16	Operating Status	Status
6	OverThrusts	Statistics
3	Ovt Prot	Setup Checklist
15	Ovt Prot	Thrust Setup
6	Pk Thrust	Statistics
4	Poll addr	Device Information
12	Pos S/N	PositionSnsrSetup
1	Position	Online
5	PositionSnsrSetup	Configuration
3	PositionUnit	Setup Checklist
11	PositionUnit	General Setup
9	PresCPS V	Calibration Trim
12	PresCPS V	PositionSnsrSetup
8	RealTimeClock	Diagnostics
7	Reset Stall	Manual Operation
5	Restore to Factory	Configuration
6	Reversals	Statistics
4	Review	Device Information
21	RTC Day	RealTimeClock
21	RTC Month	RealTimeClock
21	RTC Year	RealTimeClock
18	Seg 1	CW Torque
19	Seg 1	CCW Torque
18	Seg 10	CW Torque
19	Seg 10	CCW Torque
18	Seg 2	CW Torque
19	Seg 2	CCW Torque

18	Seg 3	CW Torque
19	Seg 3	CCW Torque
18	Seg 4	CW Torque
19	Seg 4	CCW Torque
18	Seg 5	CW Torque
19	Seg 5	CCW Torque
18	Seg 6	CW Torque
19	Seg 6	CCW Torque
18	Seg 7	CW Torque
19	Seg 7	CCW Torque
18	Seg 8	CW Torque
19	Seg 8	CCW Torque
18	Seg 9	CW Torque
19	Seg 9	CCW Torque
12	Set Pos 0%	PositionSnsrSetup
12	Set Pos 100% Span	PositionSnsrSetup
4	Setup	Device Information
2	Setup Checklist	Functions
3	ShutDwnThr	Setup Checklist
15	ShutDwnThr	Thrust Setup
12	Snsr Dir	PositionSnsrSetup
3	Stall Time	Setup Checklist
11	Stall Time	General Setup
3	StallProt	Setup Checklist
11	StallProt	General Setup
6	Stalls	Statistics
6	Starts	Statistics
2	Statistics	Functions
8	Status	Diagnostics
3	StepSize	Setup Checklist
11	StepSize	General Setup
16	Switch Status	Status
4	Tag	Device Information
1	Temp	Online
3	Temperature Unit	Setup Checklist
11	Temperature Unit	General Setup
8	Tests	Diagnostics
5	Thrust Setup	Configuration
6	TotRunTm	Statistics
3	Travel	Setup Checklist
11	Travel	General Setup
3	Thr Const	Setup Checklist
15	Thr Const	Thrust Setup
3	Thr Null	Setup Checklist
15	Thr Null	Thrust Setup
3	Thr Snsr	Setup Checklist
15	Thr Snsr	Thrust Setup
1	Trq/Thrust	Online
9	Trq/Thrust	Calibration Trim
5	Use Default Setup	Configuration

DCM-3 HART Messages

Common HART Messages

HART protocol maintains both standard and device-specific informational messages that are displayed on the HART host when various

conditions occur. Below is a table of typical Beck actuator messages and message sequences. It does not include all possible messages, only the most common.

Output Shaft Position Measurement Messages

Message	Description
Process applied to the primary variable is outside the operating limits of the field device.	This is a standard HART-defined message that appears whenever the position signal from the CPS-5, as measured at the DCM-3, is outside the design or calibrated range. This message should be accompanied by a Beck-specific message with more detail.
The Position Signal is less than -5% or greater than 105%.	This Beck-specific message indicates the DCM-3 is reading a CPS-5 signal that is not within the expected calibration range. Refer to OUTPUT SHAFT POSITION SENSING (page 26).
Position signal in LOS.	This is a Beck-specific message. The DCM-3 is reading a CPS-5 signal that is outside of the range associated with a functional CPS-5. Refer to OUTPUT SHAFT POSITION SENSING (page 26).
Position out of accurate measurement range.	This is a Beck-specific message. The DCM-3 is reading a CPS-5 signal that is outside of the range for accurate measurements. Refer to OUTPUT SHAFT POSITION SENSING (page 26).
Position sensing error.	This is a Beck-specific message. The DCM-3 circuitry for measuring the CPS-5 signal does not appear to be functioning properly.
Analog output 1 and its digital representation are outside the operating range limits, and not responding to input.	This is a standard HART®-defined message that appears whenever the position signal from the CPS-5, as measured at the DCM-3, is outside the range for accurate measurements. Refer to OUTPUT SHAFT POSITION SENSING (page 26). This message should be accompanied by a Beck-specific message with more detail.

Handswitch and Over-travel Limit Switch Message

Message	Description
Motor power is blocked, check switches.	This message will appear if a condition beyond control of the DCM-3 microcomputer prevents current flow to the motor. Refer to STOP/LIMIT INDICATION (page 20).

Stall Protection Message

Message	Description
Stall condition has been detected (see "Stall Time" in the "General Setup" menu).	This is a Beck-specific message indicating that the Stall Protection timer has determined an alarm exists. Refer to STALL PROTECTION (page 21).

Demand and Temperature Measurement Messages

Message	Description
Process applied to the non-primary variable is outside the operating limits of the field device.	This is a standard HART-defined message that appears whenever the Demand signal, Torque, or Temperature are outside their design or calibrated ranges. This message should be accompanied by a Beck-specific message with more detail.
The Demand Signal is outside of the intended limits (see Demand Setup menu).	This Beck-specific message indicates the Demand signal is invalid. Refer to LOSS OF DEMAND SIGNAL (L.O.S.) (page 23).
Demand out of accurate measurement range.	This is a Beck-specific message. The Demand signal is out of the reliable measurement range. The lower and upper limits are 0.1 Vdc and 5.5 Vdc, respectively. Note that current input DCM-3 boards utilize a 250 Ohm input resistor to convert the current signal to voltage.
Demand Signal is out of limit.	This Beck-specific message indicates the Demand signal is too high to measure accurately. The upper limits is 5.5 Vdc. Note that current input DCM-3 boards utilize a 250 Ohm input resistor to convert the current signal to voltage.
Demand sensing error.	This is a Beck-specific message. The Demand sensing circuitry does not appear to be functioning properly.
The temperature is outside of -40°F to 185°F.	This is a Beck-specific message indicating that the temperature at the DCM-3 is outside of the acceptable range. Refer to TEMPERATURE SENSING (page 20).
Temperature out of accurate measurement range.	This is a Beck-specific message. The DCM-3 ambient temperature reading is extreme to the point of uncertainty.
Temperature A/D Fail.	This is a Beck-specific message. The DCM-3 circuitry for measuring the ambient temperature does not appear to be functioning properly.
The Feedback Signal is enabled but the loop is open.	This is a Beck-specific message indicating that the Feedback sourcing circuit is unable to create the proper signal current. Refer to CONFIGURING FEEDBACK (page 29).

DCM-3 HART Messages

Questionable Configuration Messages

Message	Description
Analog output 1 and its digital representation are in fixed mode, and not responsive to input changes.	This is a standard HART-defined message that appears whenever the Feedback signal has been manually assigned a value. Refer to FB Out Test: (page 42). This message should be accompanied by a Beck-specific message with more detail.
Feedback is in fixed mode.	This is a Beck-specific message indicating that the Feedback output signal is in a manually controlled mode, and probably does not represent the output shaft position. Refer to FB Out Test: (page 42).
Local control button pressed while locked-out.	This is a Beck-specific message indicating an incorrect combination of pushbuttons is being pressed on the local configuration interface, or the local control interface is disabled and a pushbutton is being pressed.
Loop Current Detected while under HART/FF Control.	This is a Beck specific alarm message that alerts the user that analog current is present on the Demand terminals, but the DCM-3 is in an Op Mode expecting digital control. Make certain the Op Mode parameter is set properly. Refer to Op Mode parameter (page 23).
Loop Current Detected while set for LOS PAT.	This is a Beck specific alarm message that alerts the user that analog current is present on the Demand terminals, but the DCM-3 is set to a LOS mode intended to be used without an analog signal. Refer to LOSS OF DEMAND SIGNAL (L.O.S.) (page 23).

DCM-3 Failure Messages

Message	Description
Real Time Clock hardware failure.	This is a Beck-specific message. The data in the Real Time Clock appears invalid. Refer to Real Time Clock Menu (page 43).
FRAM Memory has failed.	This is a Beck-specific message. The continuous built-in self-test cannot verify the memory for statistics information is operating properly.
Memory failure.	This is a Beck-specific message. The continuous built-in self-test cannot verify the microcomputer is operating properly.

Miscellaneous HART-Defined Messages

Message	Description
Field device has more status available.	This is a standard HART-defined message that appears whenever the DCM-3 signals the HART host that an alarm or other undesirable status exists. This is the HART protocol mechanism for displaying the other messages displayed in this section. If this message is displayed without an additional message, the status cleared before the HART host read the additional status.
A reset or self test of the field device has occurred, or power has been removed and reapplied.	This message is presented by the HART host if the DCM-3 has gone through a power-up reset sequence since the last communication with the host. This message is only displayed once after a reset.
A modification has been made to the configuration of the field device.	This message indicates that the DCM-3 has undergone a configuration change since the last time the HART host has reset the change flag. Many HART hosts disregard the flag and do not report this message.
Field device has malfunctioned due to a hardware error or failure.	This message indicates that the continuous built-in self-test cannot verify the microcomputer is operating properly.

FOUNDATION FIELDBUS Parameters

FOUNDATION FIELDBUS PARAMETER PRESENTATION

The Beck DCM-3 parameters are accessed through five Foundation Fieldbus blocks: Resource, Transducer, Analog Out, Analog In 1, and Analog In 2. All of the blocks except the Transducer Block are standard Foundation Fieldbus blocks. The Transducer block is a custom block, and is the access path to most Beck-specific information. For more information on the other blocks, refer to Foundation Fieldbus Communication Overview (page 11).

Foundation Fieldbus networks are able to access the information in the standard blocks using data structure information provided by the Fieldbus Foundation. In order to access the data in the Transducer Block, a Device Description (DD) file is required.

The DD is used by fieldbus access tools to identify Beck-specific information. The DD for Foundation Fieldbus contains a set of menus which are similar to the HART menus, and provides a data list for the Transducer Block. Depending on the access tool, the menus may not be available to the technician. Also, the presentation of the data list varies significantly from system to system.

Some data in the Transducer Block is contained in groups of data called Records. Record names are included in the data list presented here in case the access tool emphasizes the record structure. The notation NameA: NameB is intended to indicate record A contains parameter B.

Some access tools can be customized to present certain data pieces in certain windows. If more data appears in the list supplied here than in the list in the access tool, check alternate windows or views.

CHANGING PARAMETER VALUES

Foundation Fieldbus distinguishes between parameters that are read-write and parameters that are read-only. There is also a technique of writing parameters as a command action. The command actions write values but do not read values. The Beck DD uses these three parameter classifications.

Parameters that are read-only cannot be written at any time. If the fieldbus access tools provide for automatic updating of values, the values should update without manual intervention. The Beck DCM-3 always provides up-to-date parameter information.

Parameters that are read-write can be changed by the technician, but changes have restrictions.

Some fieldbus access tools may apply restrictions based on user names or passwords. The Beck DCM-3 does not implement restrictions of this sort.

Foundation Fieldbus allows most changes to be blocked unless the mode of the block is set to OOS (Out of Service). The Beck DD uses this OOS requirement to protect the system from changes during loop operation. Therefore, parameter writes are blocked unless the mode is set to OOS.

PARAMETER LISTING

Two presentations of the Transducer Block are shown on the following pages. The first listing is in the order the data is listed in the DD. The second listing is an index to allow a person to find a parameter by label and then, from that, identify the data in the first listing.

In the first listing, the Relative Index column is for reference purposes only, and does not indicate an exact line count or computer index-value.

Parameters that are members of records are shown by the record index followed by the parameter label. Parameters that are not members of records are shown simply as the label name.

In the second listing, the parameters are shown in alphabetical order. The Relative Index-value can be used to find the parameter in the first listing.

RELATIONSHIP AMONG BLOCKS

The five Foundation Fieldbus blocks include three that are function blocks (Analog Out and two Analog In), the Resource Block, and the Transducer Block. The Resource Block contains access to some hardware level functions, but is not used in normal operation of the DCM-3. The Transducer Block and the three function blocks interact to operate the actuator.

In general, the Transducer Block establishes the configuration of the DCM-3 and the function blocks provide real time access for control and monitoring. The Transducer Block also displays the real time values some parameters in function blocks.

CONTROLLING THE ACTUATOR: ANALOG OUT

The Analog Out function block provides cascade control of the actuator. Because this is a standard Foundation Fieldbus AO function block, the operation of the block is the same as other standard AO blocks. Using this block requires knowledge of the relationship of the AO parameters to the Transducer Block and the Beck DCM-3 configuration.

Two of the AO parameters are particularly important in the Beck application: CAS_IN and PV. CAS_IN is read by the DCM-3 as the Demand signal. PV is read from the DCM-3 as the actual position of the output shaft.

Both the Demand and the actual shaft position are also available in the Transducer Block. Demand is available as Demand % (reference line 15), and the actual output shaft position is available as Position % (reference line 13).

Other parameters in the Transducer Block are related to the Demand and Position. Some of the parameters modify the actuator performance and some of the parameters give additional details.

One of the most important Transducer Block parameters is the parameter for determining the rotation direction of the output shaft in response to an increasing Demand signal. This parameter is in the Info 2 record, and is called Actuator Dir. The formal name is Info 2: Actuator Dir.

These related parameters are informational:

Demand Unit	read-only
Position Unit	read-only
Position(deg/in/mm)	in for Group 14
CPS Ranges:CPS Output Unit	read only
CPS Ranges:CPS Span	page 26
MaxTravel(deg/in/mm)	page 26
Position Limits: PosLwrLim	page 26
Position Limits: PosUprLim	page 26
Position Sense:Pres V	
Position Sense:Unit	
SigDif:DemPosDif	
SigDif:DemPosDif Unit	
Unit Select(deg/in/mm)	

These parameters change the operation:

Op Mode
 CPS Ranges:CPS Zero%
 CPS Ranges:CPS RngLwr
 CPS Ranges:CPS RngUpr
 Demand Source
 Demand Curve
 Info 2:Actuator Dir
 Info 2:StepSize
 Info 2:Max Error
 Snsr Dir
 Travel(deg/in/mm)

FOUNDATION FIELDBUS Transducer Block

Transducer Block Listing

Relative Index	Record Name (if applicable): Parameter Label	Use
1	ST_REV	fieldbus use, no Beck use
2	TAG_DESC	fieldbus use, no Beck use
3	STRATEGY	fieldbus use, no Beck use
4	ALERT_KEY	fieldbus use, no Beck use
5	MODE_BLK	typically Auto or CASCADE
6	BLOCK_ERR	fieldbus use
7	EVENT_UPDATE	fieldbus use
8	BLOCK_ALM	fieldbus use
9	TRANSDUCER_DIRECTORY	fieldbus use
10	TRANSDUCER_TYPE	fieldbus use
11	XD_ERROR	fieldbus use
12	COLLECTION_DIRECTORY	fieldbus use
13	Position %	present actuator position
14	Position Unit	unit of measure for Position %
15	Demand %	present actuator Demand
16	Demand Unit	unit of measure for Demand %
17	Op Mode	Demand Operating Mode
18	Trq/Thr %	present output shaft Torque load
19	Trq/Thr Unit	not used in Group 14
20	Ambient Temp	present DCM-3 temperature
21	Temp Unit	unit of measure for Ambient temperature
22-1	Inhibits: EXT 2 Inhibitor	not used in Group 14
22-2	Inhibits: EXT 1 Inhibitor	reason motor is not extending output shaft
22-3	Inhibits: RET 2 Inhibitor	not used in Group 14
22-4	Inhibits: RET 1 Inhibitor	Reason motor is not retracting output shaft
22-5	Inhibits: LED Status	allows remote checking of which LED's on the DCM-3 are illuminated
22-6	Inhibits: Switch Status	not used in Group 14
23-1	DCM BIST: Operating Status	summary of process-related conditions
23-2	DCM BIST: BIST 1	built-in self-test results
23-3	DCM BIST: BIST 2	built-in self-test results
23-4	DCM BIST: BIST 3	built-in self-test results
23-5	DCM BIST: analog_output_fixed1	not used in Group 14
23-6	DCM BIST: Analog Sig Saturated	analog signals are out of measurement range
24-1	SigDif: DemPosDiff Unit	unit of measure for DemPosDiff
24-2	SigDif: DemPosDiff	the difference between the Demand and the Position
25-1	Statistics: TotalRunTm	total amount of time the motor has been powered
25-2	Statistics: OverTrqs/Thrusts	not used in Group 14
25-3	Statistics: Peak Trq/Thr	not used in Group 14
25-4	Statistics: Reversals	the total number of times the motor has started in the direction opposite to the previous start
25-5	Statistics: Stalls	the total number of times the stall timer has timed out
25-6	Statistics: Starts	the total number of motor starts
25-7	Statistics: LastRun	the duration of the last motor movement
25-8	Statistics: Set up OverTrqs/Thrusts	not used in Group 14
25-9	Statistics: Set up OverTrqs/Thrusts	not used in Group 14

26-1	Ambient Extreme: High highest	highest temperature recorded in the DCM-3 compartment
26-2	Ambient Extreme: Low	lowest temperature recorded in the DCM-3 compartment
27-1	Ambient Rating: Temp Lwr Lim	temperature allowed before alarm asserted
27-2	Ambient Rating: Temp Upr Lim	temperature allowed before alarm asserted
28	Position(deg/in/mm)	Position % (Relative Index 13) expressed in engineering units of degrees
29	Unit Select(deg/in/mm)	unit of measure for Position (Relative Index 28), always in for Group 14
30-1	Position Sense: Unit	unit of measure for DCM-3 sensing circuit that receives the signal from the CPS-2, always volts
30-2	Position Sense: Pres V	displays the output shaft position voltage signal at the DCM-2 from the CPS-2
31-1	CPS Ranges: CPS Output Unit	unit of measure for CPS-2 output signal to the DCM-3, always volts
31-2	CPS Ranges: CPS Zero%	this is the voltage from the CPS-2 to the DCM-3 that the DCM-3 will interpret as 0% output shaft position
31-3	CPS Ranges: CPS Span	the voltage span from the CPS-2 for the maximum travel of the output shaft. This is simply the upper range voltage minus the lower range voltage
31-4	CPS Ranges: CPS RngLwr	the CPS-2 voltage signal corresponding to the extend end of travel when Travel is set to the maximum range
31-5	CPS Ranges: CPS RngUp	the CPS-2 voltage signal corresponding to the retract end of travel when Travel is set to the maximum range
32-1	Position Limits: PosLwrLim	Position Lower Limit, the signal in percent allowed before an alarm is asserted
32-2	Position Limits: PosUpLim	Position Upper Limit, the signal in percent allowed before an alarm is asserted
33	Snsr Dir	the direction of output shaft travel that causes the CPS-2 signal to increase. Except in some custom configurations, this direction should always be retract
34	MaxTravel(deg/in/mm)	the maximum output shaft travel for this model of actuator
35	Travel(deg/in/mm)	amount of output shaft travel for 100% signal change

FOUNDATION FIELDBUS Transducer Block

Transducer Block Listing (cont'd)

Relative Index	Record Name (if applicable): Parameter Label	Use
36-1	RET Trq/Thr: 1	not used in Group 14
36-2	RET Trq/Thr: 2	not used in Group 14
36-3	RET Trq/Thr: 3	not used in Group 14
36-4	RET Trq/Thr: 4	not used in Group 14
36-5	RET Trq/Thr: 5	not used in Group 14
36-6	RET Trq/Thr: 6	not used in Group 14
36-7	RET Trq/Thr: 7	not used in Group 14
36-8	RET Trq/Thr: 8	not used in Group 14
36-9	RET Trq/Thr: 9	not used in Group 14
36-10	RET Trq/Thr: 10	not used in Group 14
37-1	RET Trq/Thr Pos: 1	not used in Group 14
37-2	RET Trq/Thr Pos: 2	not used in Group 14
37-3	RET Trq/Thr Pos: 3	not used in Group 14
37-4	RET Trq/Thr Pos: 4	not used in Group 14
37-5	RET Trq/Thr Pos: 5	not used in Group 14
37-6	RET Trq/Thr Pos: 6	not used in Group 14
37-7	RET Trq/Thr Pos: 7	not used in Group 14
37-8	RET Trq/Thr Pos: 8	not used in Group 14
37-9	RET Trq/Thr Pos: 9	not used in Group 14
37-10	RET Trq/Thr Pos: 10	not used in Group 14
38-1	EXT Trq/Thr: 1	not used in Group 14
38-2	EXT Trq/Thr: 2	not used in Group 14
38-3	EXT Trq/Thr: 3	not used in Group 14
38-4	EXT Trq/Thr: 4	not used in Group 14
38-5	EXT Trq/Thr: 5	not used in Group 14
38-6	EXT Trq/Thr: 6	not used in Group 14
38-7	EXT Trq/Thr: 7	not used in Group 14
38-8	EXT Trq/Thr: 8	not used in Group 14
38-9	EXT Trq/Thr: 9	not used in Group 14
38-10	EXT Trq/Thr: 10	not used in Group 14
39-1	EXT Trq/Thr Pos: 1	not used in Group 14
39-2	EXT Trq/Thr Pos: 2	not used in Group 14
39-3	EXT Trq/Thr Pos: 3	not used in Group 14
39-4	EXT Trq/Thr Pos: 4	not used in Group 14
39-5	EXT Trq/Thr Pos: 5	not used in Group 14
39-6	EXT Trq/Thr Pos: 6	not used in Group 14
39-7	EXT Trq/Thr Pos: 7	not used in Group 14
39-8	EXT Trq/Thr Pos: 8	not used in Group 14
39-9	EXT Trq/Thr Pos: 9	not used in Group 14
39-10	EXT Trq/Thr Pos: 10	not used in Group 14
40	Trq/Thr	not used in Group 14
41	Trq/Thr AlarmLevel	not used in Group 14
42	Trq/Thr Shut Dn Level	not used in Group 14
43	Trq/Thr Sensor Unit	not used in Group 14
44-1	Trq/Thr Range: Trq/Thr Null	not used in Group 14
44-2	Trq/Thr Range: Trq/Thr Const	not used in Group 14
45	Trq/Thr Cal Unit	not used in Group 14

46	Drive S/N	the serial number as shown on the actuator nameplate.
47	Model#	a field that is created within the DCM-3 by examining Drive S/N. If this field does not match the model of actuator, change Drive S/N.
48	Type	a broad classification of DCM-3 type based on Drive S/N
49-1	Info 1: Shaft Dir	not used on Group 14
49-2	Info 1: Geometry	classification of output shaft movement: linear or rotary
49-3	Info 1: Embed Mem	not used on Group 14
49-4	Info 1: groupNumber	Beck Group number based on Drive S/N
49-5	Info 1: HandSwType	identifies whether Handswitch is a full power bypass of the DCM-3 or a low voltage input to the DCM-3
49-6	Info 1: LimSwType	identifies whether the over-travel limit switches act to block motor power or are low voltage inputs to the DCM-3
49-7	Info 1: modelNumber	model number based on Drive S/N
49-8	Info 1: Gear Ratio	not used on Group 14
49-9	Info 1: Gear Units	not used on Group 14
49-10	Info 1: Motor Poles	not used on Group 14
49-11	Info 1: Pole Units	not used on Group 14
49-12	Info 1: OutRating	not used on Group 14
49-13	Info 1: Output Units	not used on Group 14
49-14	Info 1: StrainGage	not used on Group 14
49-15	Info 1: StrainUnits	not used on Group 14
49-16	Info 1: ScrewTrav	not used on Group 14
49-17	Info 1: ScrewTravUnits	not used on Group 14
50-1	Info 2: LocalCntrl	not used on Group 14 for Foundation Fieldbus
50-2	Info 2: LOS Mode	not used on Group 14 for Foundation Fieldbus
50-3	Info 2: LOS Pos	not used on Group 14 for Foundation Fieldbus
50-4	Info 2: LimitSwitch	modifies the behavior of Stop/Limit alarm.
50-5	Info 2: Trq/Thr Protect	not used on Group 14
50-6	Info 2: StepSize	the typical smallest Demand change that will cause an output shaft movement.
50-7	Info 2: Max Error	if the Demand signal doesn't change and a technician moves the Handwheel back and forth, this is the theoretical maximum movement translated to the output shaft.
50-8	Info 2: Drive Dir	the direction the output shaft moves in response to an increasing Demand signal.
50-9	Info 2: Stall Time	the amount of time the motor will run before Stall Protection
50-10	Info 2: Handswitch	the Handswitch is always enabled
51	StallProtect	whether actuator motor will be turned off if the Stall Time counter expires.
52-1	Info 3: Flag Status	a copy of some data from the DCM BIST parameters
52-2	Info 3: Operating Status Alt	a copy of some data from the DCM BIST parameters
52-3	Info 3: Present Freq	not used on Group 14
52-4	Info 3: DC Volts	not used on Group 14
52-5	Info 3: Line Freq	the power line frequency as measured by the DCM-3
53	Power	the Group 14 is designed for 1-phase power
54	Max Freq	not used on Group 14
55	MaxTravelTm:	not used on Group 14
56	Feedback	with fieldbus, only used for special retrofit applications

FOUNDATION FIELDBUS Transducer Block

Transducer Block Listing (cont'd)

Relative Index	Record Name (if applicable): Parameter Label	Use
57-1	Alarm Contact: Polarity	whether the solid state relay opens on alarm or closes on alarm.
57-2	Alarm Contact: Mask 1	which alarms cause the solid state relay to change state.
57-3	Alarm Contact: Mask 2	which alarms cause the solid state relay to change state.
58	Demand Source	in Group 14 fieldbus applications, should read HART/FF
59	Demand Curve	whether Demand is interpreted as linear or a curve.
60-1	DemNode1: DemNode1X	allows setting the Demand characterization nodes
60-2	DemNode1: DemNode1Y	allows setting the Demand characterization nodes
61-1	DemNode2: DemNode2X	allows setting the Demand characterization nodes
61-2	DemNode2: DemNode2Y	allows setting the Demand characterization nodes
62-1	DemNode3: DemNode3X	allows setting the Demand characterization nodes
62-2	DemNode3: DemNode3Y	allows setting the Demand characterization nodes
63-1	DemNode4: DemNode4X	allows setting the Demand characterization nodes
63-2	DemNode4: DemNode4Y	allows setting the Demand characterization nodes
64-1	DemNode5: DemNode5X	allows setting the Demand characterization nodes
64-2	DemNode5: DemNode5Y	allows setting the Demand characterization nodes
65-1	DemNode6: DemNode6X	allows setting the Demand characterization nodes
65-2	DemNode6: DemNode6Y	allows setting the Demand characterization nodes
66-1	DemNode7: DemNode7X	allows setting the Demand characterization nodes
66-2	DemNode7: DemNode7Y	allows setting the Demand characterization nodes
67-1	DemNode8: DemNode8X	allows setting the Demand characterization nodes
67-2	DemNode8: DemNode8Y	allows setting the Demand characterization nodes
68-1	DemNode9: DemNode9X	allows setting the Demand characterization nodes
68-2	DemNode9: DemNode9Y	allows setting the Demand characterization nodes
69-1	DemNode10: DemNode10X	allows setting the Demand characterization nodes
69-2	DemNode10: DemNode10Y	allows setting the Demand characterization nodes
70-1	DemNode11: DemNode11X	allows setting the Demand characterization nodes
70-2	DemNode11: DemNode11Y	allows setting the Demand characterization nodes
71-1	DemNode12: DemNode12X	allows setting the Demand characterization nodes
71-2	DemNode12: DemNode12Y	allows setting the Demand characterization nodes
72-1	DemNode13: DemNode13X	allows setting the Demand characterization nodes
72-2	DemNode13: DemNode13Y	allows setting the Demand characterization nodes
73-1	DemNode14: DemNode14X	allows setting the Demand characterization nodes
73-2	DemNode14: DemNode14Y	allows setting the Demand characterization nodes
74-1	DemNode15: DemNode15X	allows setting the Demand characterization nodes
74-2	DemNode15: DemNode15Y	allows setting the Demand characterization nodes
75-1	DemNode16: DemNode16X	allows setting the Demand characterization nodes
75-2	DemNode16: DemNode16Y	allows setting the Demand characterization nodes
76-1	DemNode17: DemNode17X	allows setting the Demand characterization nodes
76-2	DemNode17: DemNode17Y	allows setting the Demand characterization nodes
77-1	DemNode18: DemNode18X	allows setting the Demand characterization nodes
77-2	DemNode18: DemNode18Y	allows setting the Demand characterization nodes
78-1	DemNode19: DemNode19X	allows setting the Demand characterization nodes
78-2	DemNode19: DemNode19Y	allows setting the Demand characterization nodes
79-1	DemNode20: DemNode20X	allows setting the Demand characterization nodes
79-2	DemNode20: DemNode20Y	allows setting the Demand characterization nodes
80-1	DemNode21: DemNode21X	allows setting the Demand characterization nodes
80-2	DemNode21: DemNode21Y	allows setting the Demand characterization nodes

81	Device Status	
82-1	Misc Status: analog_output_fixed2	
82-2	Misc Status: analog_output_fixed3	
82-3	Misc Status: analog_output_saturated2	
82-4	Misc Status: analog_output_saturated3	
82-5	Misc Status: xmtr_specific_status_4	
82-6	Misc Status: xmtr_specific_status_5	
83-1	Installed Features: Pot Supply	
83-2	Installed Features: FB Out	
83-3	Installed Features: Trq/Thr Snsr	
84	Board Mfd	
85	Calbrtd	
86	Setup	
87-1	RT Clock: Day	
87-2	RT Clock: Month	
87-3	RT Clock: Year	
87-4	RT Clock: Hour (24)	
87-5	RT Clock: Minute	
87-6	RT Clock: Second	
87-7	RT Clock: rtc_status	
88-1	Beck Software Info: DCM Software Rev	
88-2	Beck Software Info: Checksum	
89	Device ID	
90	Status	
91	Reset Settings	
92	Write Pro	
93	Reset Changed Flag	
94	Perform Test	
95	Reset	
96	Identify	
97	Reset Stall	

RESET SETTINGS

The parameter causes an action. There are three choices:

- 1 **Recall factory settings:** this returns the DCM-3 to the configuration as shipped from the factor. (Restore Factory Configuration, page 20).
- 2 **Use Model Defaults:** update the DCM-3 configuration related to the CPS-5 signals based on the model number. (Setting Model Defaults, page 26).
- 3 **Reset Board:** this reset simulates switching the power off and back on.

FOUNDATION FIELDBUS Transducer Block

Transducer Block Cross Reference

Label	Reference Index
ALERT_KEY	4
Ambient Temp	20
Analog Sig Saturated	23-6
analog_output_fixed1	23-5
analog_output_fixed2	82-1
analog_output_fixed3	82-2
analog_output_saturated2	82-3
analog_output_saturated3	82-4
BIST 1	23-2
BIST 2	23-3
BIST 3	23-4
BLOCK_ALM	8
BLOCK_ERR	6
Board Mfd	84
Calbrtd	85
EXT 1 Inhibitor	22-2
EXT 2 Inhibitor	22-1
EXT Trq/Thr	38-1
EXT Trq/Thr Pos	39-1
Checksum	88-2
COLLECTION_DIRECTORY	12
CPS Output Unit	31-1
CPS RngLwr	31-4
CPS RngUp	31-5
CPS Span	31-3
CPS Zero%	31-2
RET 1 Inhibitor	22-4
RET 2 Inhibitor	22-3
RET Trq/Thr	36-1
RET Trq/Thr Pos	37-1
Day	87-1
DC Volts	52-4
DCM Software Rev	88-1
Demand %	15
Demand Curve	59
Demand Source	58
Demand Unit	16
DemNode10X	69-1
DemNode10Y	69-2
DemNode11X	70-1
DemNode11Y	70-2
DemNode12X	71-1
DemNode12Y	71-2
DemNode13X	72-1
DemNode13Y	72-2
DemNode14X	73-1
DemNode14Y	73-2
DemNode15X	74-1
DemNode15Y	74-2

DemNode16X	75-1
DemNode16Y	75-2
DemNode17X	76-1
DemNode17Y	76-2
DemNode18X	77-1
DemNode18Y	77-2
DemNode19X	78-1
DemNode19Y	78-2
DemNode1X	60-1
DemNode1Y	60-2
DemNode20X	79-1
DemNode20Y	79-2
DemNode21X	80-1
DemNode21Y	80-2
DemNode2X	61-1
DemNode2Y	61-2
DemNode3X	62-1
DemNode3Y	62-2
DemNode4X	63-1
DemNode4Y	63-2
DemNode5X	64-1
DemNode5Y	64-2
DemNode6X	65-1
DemNode6Y	65-2
DemNode7X	66-1
DemNode7Y	66-2
DemNode8X	67-1
DemNode8Y	67-2
DemNode9X	68-1
DemNode9Y	68-2
DemPosDiff	24-2
DemPosDiff Unit	24-1
Device ID	89
Device Status	81
Drive Dir	50-8
Drive S/N	46
Embed Mem	49-3
EVENT_UPDATE	7
FB Out	83-2
Feedback	56
Flag Status	52-1
Gear Ratio	49-8
Gear Units	49-9
Geometry	49-2
groupNumber	49-4
Handswitch	50-10
HandSwType	49-5
High	26-1
Hour (24)	87-4
Identify	96
LastRun	25-7

LED Status	22-5
LimitSwitch	50-4
LimSwType	49-6
Line Freq	52-5
LocalCntrl	50-1
LOS Mode	50-2
LOS Pos	50-3
Low	26-2
Mask 1	57-2
Mask 2	57-3
Max Error	50-7
Max Freq	54
MaxTravel(deg/in/mm)	34
MaxTravelTm:	55
Minute	87-5
MODE_BLK	5
Model#	47
modelName	49-7
Month	87-2
Motor Poles	49-10
Op Mode	17
Operating Status	23-1
Operating Status Alt	52-2
Output Units	49-13
OutRating	49-12
OverTrqs/Thrusts	25-2
Peak Trq/Thr	25-3
Perform Test	94
Polarity	57-1
Pole Units	49-11
Position %	13
Position Unit	14
Position(deg/in/mm)	28
PosLwrLim	32-1
PosUprLim	32-2
Pot Supply	83-1
Power	53
Pres V	30-2
Present Freq	52-3
Reset	95
Reset Changed Flag	93
Reset Settings	91
Reset Stall	97
Reversals	25-4
rtc_status	87-7
ScrewTrav	49-16
ScrewTravUnits	49-17
Second	87-6
Set up OverTrqs/Thrusts	25-8
Set up Peak Trq/Thr	25-9

Setup	86
Shaft Dir	49-1
Snsr Dir	33
ST_REV	1
Stall Time	50-9
StallProtect	51
Stalls	25-5
Starts	25-6
Status	90
StepSize	50-6
StrainGage	49-14
StrainUnits	49-15
STRATEGY	3
Switch Status	22-6
TAG_DESC	2
Temp Lwr Lim	27-1
Temp Unit	21
Temp Upr Lim	27-2
TotalRunTm	25-1
TRANSDUCER_DIRECTORY	9
TRANSDUCER_TYPE	10
Travel(deg/in/mm)	35
Trq/Thr	40
Trq/Thr %	18
Trq/Thr AlarmLevel	41
Trq/Thr Cal Unit	45
Trq/Thr Const	44-2
Trq/Thr Null	44-1
Trq/Thr Protect	50-5
Trq/Thr Sensor Unit	43
Trq/Thr Shut Dn Level	42
Trq/Thr Snsr	83-3
Trq/Thr Unit	19
Type	48
Unit	30-1
Unit Select(deg/in/mm)	29
Write Protect	92
XD_ERROR	11
xmtr_specific_status_4	82-5
xmtr_specific_status_5	82-6
Year	87-3

TROUBLESHOOTING

DIAGNOSTICS

Several different diagnostic tools exist. This instruction manual includes several flow charts that can be used with or without the aid of a computer interface. If available, Foundation Fieldbus, HART, and the Beck Configuration Port can each provide significant help finding problems.

To begin diagnosing a situation, a technician should consider the following questions.

1. What seems wrong? Does the output shaft position reflect the Demand signal? Is output shaft movement irregular? Is the DCM-3 configuration correct?
2. Can the problem be categorized? Is the control system unsettled? Is there a mechanical problem? Does the problem appear electrical?
3. What is the condition of the control system? Is the actuator in the process of being installed? Has the process changed? Does the actuator have proper power and proper signals from the control system?

CHECKING HANDSWITCH OPERATION

The Handswitch on the Group 14 actuator bypasses the DCM-3 circuit board. When troubleshooting the actuator, the Handswitch can be used to help determine if there is a problem with the DCM-3 or with other components of the actuator.

In practice, if the actuator does not appear to be operating properly in Auto mode (MODES OF OPERATION, page 15), a technician can try the Handswitch to see if the actuator runs properly with the Handswitch.

Proper operation is described as runs in both directions, starts well, runs in the correct direction, run smoothly, and stops at the appropriate over-travel limit switch (Control End Overview, page 32).

If proper Handswitch operation is observed, proceed with troubleshooting the actuator electronics. Some indication of the problem can be seen by observing the power (PWR) and three status LED's on the DCM-3. For information on these LED's refer to Troubleshooting Using Local LED's (page 61). Detailed information for Foundation Fieldbus DCM-3's is found on page 62 and for HART DCM-3's is found on page 66.

If Handswitch operation is improper, analyze the symptoms.

1. An actuator that runs in one direction but not the other is probably having difficulty with an over-travel limit switch.
2. An actuator that is starting poorly and often runs in the wrong direction is probably having trouble with the motor resistor-capacitor.
3. If the motor direction is correct but the actuator is not starting smoothly, there is probably too much torque load on the output shaft.

NOTE: The field wiring terminal block connections mentioned here are for the typical system. Check the wiring diagram that came with the specific actuator.

If one of the quick descriptions does not lead to the solution, follow the Handswitch power path. Power is connected to the actuator at terminal B. Terminal C connects through to the DCM-3. Terminal C is also connected to terminal A through a top side jumper. Terminal A connects through to the Handswitch. For the Handswitch to run the motor, power has to be present at terminal A.

Power is routed through the Handswitch to terminals U or V. Terminal U is powered in RET. Terminal V is powered in EXT. With either terminal powered, a reflected voltage will show at the other terminal because of the motor windings and the motor resistor-capacitor. This reflected voltage is typically a lower reading than the line power applied between terminals A and B.

With the Handswitch in RETRACT, the voltage from terminal U to terminal B should measure the same as the line power applied to terminals A and B. With the RET switch closed, the voltage from terminal U to terminal B should be the same as the voltage from either side of the RET switch to terminal B.

With the Handswitch in EXTEND, the voltage from terminal V to terminal B should measure the same as the line power applied to terminals A and B. With the EXT switch closed, the voltage from terminal V to terminal B should be the same as the voltage from either side of the EXT switch to terminal B.

The motor does not have any internal switching mechanisms. If there is voltage on the motor and the motor does not respond, the motor requires service.

TROUBLESHOOTING USING LOCAL LEDS

All DCM-3's include built-in self-test routines that run continuously. These routines can simplify the troubleshooting process.

Detail 1: The PWR (power) LED.

Is the PWR LED illuminated? The PWR LED should be illuminated whenever power is connected to the actuator. A cleared fuse on the DCM-3 does not prevent the PWR from lighting. The PWR LED being illuminated does not mean power is within specification. The LED will illuminate with approximately 70Vac applied to the actuator.

Is the PWR LED pulsing? The PWR LED should be changing brightness approximately each second (60 times per minute). This brightness change indicates that the self-test routines are running and have not found any errors in the DCM-3 microcomputer operation. This does not mean all the process variables are within acceptable limits or that the DCM-3 is operating exactly correctly, but does mean that the onboard microcomputer is

running properly.

Detail 2: The FWD and REV LEDs

If the DCM-3 is trying to run the motor, either the FWD or the REV LED's should be illuminated. If the motor is running without one of the LED's illuminated, then either the DCM-3 is being bypassed (perhaps by the Handswitch), or the power output stage of the DCM-3 is "stuck" on.

The FWD and REV LED's indicate the signal level comparison between the Demand and the output shaft position (as measured by the CPS-5). FWD illuminated indicates the Demand is higher. REV illuminated indicates Demand is lower. Both OFF indicates either the signals are balanced, or that the DCM-3 has detected some status that prevents the motor from being run.

Detail 3: The STAT LED

The STAT (status) LED indicates the DCM-3 is aware of a problem. The severity of the problem is not immediately apparent through the STAT LED. Problems can range from relatively minor to major.

The following table lists the alarms and what the alarm means with regard to stopping the motor.

Y – alarm stops motor

N – alarm does not stop motor

C – circumstances and configuration matter

R – result of switch stopping motor

Alarm	Stop Motor?	Local Configuration Panel LED
Demand LOS	C	DEMAND
DemandMeasFail	C	DEMAND
DemandTooHigh	C	DEMAND
DemUnderHART/FF Ctl	C	DEMAND
DemUnderPAT Ctl	C	DEMAND
Torq/Thrust High	Not active in Group 14	
Torq/Thrust Stop	Not active in Group 14	
Torq/ThrustMeasFail	Not active in Group 14	
Stall	Y	STALL
Stop/Limit	R	STOP/LIMIT
FeedbackLOS	N	FEEDBACK
Temperature	N	TEMP
PositionLOS	Y	POSITION
PositionA/D Error	Y	POSITION
RTC Fail	N	—
TemperatureMeasFail	N	TEMP
MemoryFail	N	—

TROUBLESHOOTING Electronics w/ FF

TROUBLESHOOTING USING FF

The actuator should run the motor so the output shaft position matches the Demand signal. If the output shaft does not reach the desired location, there are three questions to answer:

1. Check the Demand signal. Is the DCM-3 receiving the correct Demand signal?
2. Check the shaft position. Does the DCM-3 think the output shaft position matches the Demand signal?
3. If the position doesn't match the Demand, why doesn't the DCM-3 run the motor?

FIRST CHECKS

The Foundation Fieldbus version of the DCM-3 includes a fieldbus-powered interface to permit fieldbus access to the DCM-3 operational parameters. Whenever fieldbus signaling voltage is available on the fieldbus, this interface will respond to fieldbus communication, but access to the DCM-3 parameters requires that 120Vac (or 240Vac, if appropriate) is available at the actuator power terminals.

All configuration and diagnostic settings are controlled by the fieldbus network. Therefore, the Foundation Fieldbus DCM-3 does not have a local configuration interface or the associated status LED's. It does have the standard Overview LED's and the Beck Configuration Port (page 17).

If the fieldbus connections are correct and the AC power connections are absent, the actuator will appear on the network, but the fieldbus function blocks will not update properly and the Transducer Block will not go into Auto. If the AC power connections are correct and the fieldbus connections are absent, the actuator will not operate as expected and will not appear on the network.

If the fieldbus connections are correct and the AC power connection is correct, the actuator should appear on the network, the DCM-3 FIELDBUS ACTIVE LED should blink, and the DCM-3 PWR LED should pulse. If the LED's are not as described, the DCM-3 is not operating properly.

For DCM-3 to respond properly to the Demand signal, the Resource Block and Transducer Block must both be in Auto mode, and the Analog Output Block must be in Cascade mode. Refer to Foundation Fieldbus Communication Overview (page 11).

CHECKING DEMAND

In Foundation Fieldbus systems, Demand is communicated to the DCM-3 as a percentage value through the CAS_IN input of the Analog Output function block. Using a communicator, the Demand should be readable as the process applied to that signal line. Also, the status of the CAS_IN signal should be Good.

For the CAS_IN signal line to be accepted by the Analog Output function block, the Analog Output Function Block must be in Cascade mode. Make certain the Beck Resource Block and Transducer Block modes are both Auto.

With the proper signal applied to the Analog Output block and the proper modes, the Demand value should be readable in the Transducer Block as Demand %. Also, the OpMode parameter in the Transducer Block should read Hold.

If these conditions are not as described, the DCM-3 is not accepting the correct Demand signal. Refer to Foundation Fieldbus Communication Overview (page 11).

CHECKING SHAFT POSITION

The output shaft position can be read as the PV parameter of the Analog Output Block, and can be read as Position % in the Transducer Block.

Does Position % match Demand %? The exactness of the match is controlled by the parameter Step Size (page 20). If they match, the DCM-3 is not running the motor because the signals appear to match.

If the signals match, the next question is whether Position % is correct for the actual output shaft position. Refer to OUTPUT SHAFT POSITION SENSING (page 26). The CPS-5 signal voltage as measured by the DCM-3 is available in the Transducer Block as parameter Position Sense. The actual voltage can be measured with a voltage meter between test points TP4(+) and TP1(-). Refer to DCM-3 Test Points (page 80).

POSITION AND DEMAND MISMATCH

If the shaft position and the Demand do not match and the motor is not running, then some factor is preventing the DCM-3 from running the motor. The fieldbus interface provides extensive information for finding this factor.

The Transducer Block contains two parameters that summarize why the motor is not running: one parameter for CW and one for CCW. The parameter names are CW Inhibitor and CCW Inhibitor. If the parameter is 0 (has not bits set), the motor should run that direction. If the parameter is not 0, the DCM-3 will not try to run the motor that direction. The bits that show in the parameter are the reasons the motor is not running that direction.

INHIBITORS

Label	Cause of Motor Not Running
OverTrq/Thrust	Not active in Group 14
Balance	Demand indicates motor should not run this direction.
Stall	Stall.
Supervisory	The DCM-3 is initializing.
Switch Block	Not used in Group 14 actuators
Bad Pos Sig	The Position signal from the CPS-5 is not acceptable
Bad Dem Sig	Not used on fieldbus systems.
Local Cal	Not used on fieldbus systems.

If the inhibitor parameter is 0 but the motor is not running, power to the motor is being blocked by something over which the DCM-3 microcomputer has no control. Possibility 1 listed below should lead to a Stall alarm (page 21). The other possibilities should create a Stop/Limit alarm (page 21).

1. The motor is stalled, and cannot travel. This condition is unlikely if the motor operated properly with the Handswitch. For more information on the Handswitch, refer to Checking Handswitch Operation (page 60).
2. The Handswitch or an Over-travel Limit Switch is preventing power from reaching the motor. Make certain the Handswitch is in AUTO. The Handswitch and the DCM-3 both use the same over-travel limits, so if the limits do not prevent Handswitch operation, they should not prevent DCM-3 operation.
3. Wire jumpers are missing from terminals F-N and terminals D-M on the field wiring terminal block. Most installations of Group 11 actuators with Foundation Fieldbus compatibility require these wire jumpers. Check the wiring diagram that came with the specific actuator.
4. The output section of the DCM-3 is not delivering power to the motor.
5. The DCM-3 fuse is cleared. This fuse is rated at more than twice the motor current, and the Beck motor has no significant inrush current. Therefore, only in very rare circumstances is the fuse cleared. These circumstances are generally wiring errors during customer installation. For the fuse location, refer to DCM-3 LAYOUT (page 16).

TROUBLESHOOTING Electronics w/ FF

BUILT-IN SELF-TEST (BIST)

The DCM-3 microcomputer continuously runs diagnostic routines in the background. These routines look for situations that could indicate the DCM-3 is not working reliably. Examples of tests are:

- whether a power failure has occurred
- if the motor should be running, is there motor current?
- does the temperature sensor appear to be functioning properly?

There are many built-in self-test routines. To simplify identifying test results, the tests are separated into five categories.

BIST: OPERATING STATUS

The Operating Status parameter is a summary of whether process-related conditions are inside or outside of anticipated limits. These conditions control the STATUS INDICATION LEDs (page 19).

- 9 Position:** caused by the CPS-5 signal being outside the range anticipated by the DCM-3. (OUTPUT SHAFT POSITION SENSING, page 26)
- 10 Temperature:** the ambient temperature of the DCM-3 is outside of the rating. (TEMPERATURE SENSING, page 20)
- 11 Thrust:** not used in Group 14.
- 12 Over-Thrust Stop:** Not used in Group 14.
- 13 Stalled:** a Stall alarm is active. (STALL PROTECTION, page 21)
- 14 Feedback Open:** the Feedback signal is enabled, but cannot flow the proper current. (CONFIGURING FEEDBACK, page 29)
- 15 Switch Block:** the DCM-3 cannot power the motor due to an electro-mechanical switch. Check the Handswitch and over-travel limit switches.

BIST: BIST 1

Real Time Clock hardware failure

The data in the Real Time Clock appears invalid. Refer to Real Time Clock Menu (page 43).

Torque/Thrust sensing error

Not used in Group 14.

Position sensing error

The DCM-3 circuitry for measuring the CPS-5 signal does not appear to be functioning properly.

Demand processing error

The Demand signal appears to have a data format error.

FRAM Memory has failed

The continuous built-in self-test cannot verify the memory for statistics information is operating properly.

Position signal in LOS

The DCM-3 is reading a CPS-5 signal that is outside of the range associated with a functional CPS-5. Refer to OUTPUT SHAFT POSITION SENSING (page 26).

Temperature A/D Fail

The DCM-3 circuitry for measuring the ambient temperature does not appear to be functioning properly.

Memory failure

The continuous built-in self-test cannot verify the microcomputer is operating properly.

BIST: BIST 2

Local control activity detected

The microcomputer has detected an data error related to the local configuration interface. This interface is not available with the fieldbus DCM-3.

Demand Setting is out of limit

The Demand signal appears too high, and probably has a data format error.

Current Overlimit

Not used in Group 14.

Power Source Not Nominal

Not used in Group 14.

BIST: BIST 3

Loop Current Detected while under HART/FF Control

The microcomputer configuration does not appear valid for Foundation Fieldbus.

BIST: ANALOG SIG SATURATED

Position out of accurate measurement range

The DCM-3 is reading a CPS-5 signal that is outside of the range for accurate measurements. Refer to OUTPUT SHAFT POSITION SENSING (page 26).

Demand out of accurate measurement range

The Demand signal appears too low or too high, and probably has a data format error.

Temperature out of accurate measurement range

The DCM-3 ambient temperature reading is extreme to the point of uncertainty.

Torque/Thrust out of accurate measurement range

Not used in Group 14.

TROUBLESHOOTING Electronics w/ HART

TROUBLESHOOTING USING HART

The actuator should run the motor so the output shaft position matches the Demand signal. If the output shaft does not reach the desired location, there are three questions to answer:

1. Check the Demand signal. Is the DCM-3 receiving the correct Demand signal?
2. Check the shaft position. Does the DCM-3 think the output shaft position matches the Demand signal?
3. If the position doesn't match the Demand, why doesn't the DCM-3 run the motor?

FIRST CHECKS

The DCM-3 for HART requires 120 Vac/240 Vac connections and a Demand signal connection. The Demand signal can be analog, analog with HART, or HART only. If the Demand LED is illuminated, the Demand signal is either absent or reverse polarity. If the DCM-3 PWR LED is not pulsing, the DCM-3 is not operating properly.

Analog Demand signals require the proper settings for the 0% point and the 100% point. For more information on analog signal ranges, refer to DEMAND (page 22). If using the HART network to write Demand digitally, the value must be written in percent. For more information on writing values digitally, refer to Manual Operation menu (page 40).

CHECKING DEMAND

The HART system displays the present Demand as Demand in the Online menu. The value displayed is the present Demand, regardless of the source of the Demand. This value can have the following origins:

1. the analog value measured from the signal loop.
2. the digital value entered into the Manual Operation menu (page 40).
3. a value chosen from the LOS function (page 23)

If the LOS function is active, alarm bits will be set and most HART hosts will display warnings that an alarm exists. When checking the Demand, make certain the Demand current (Loop(Dem)) and the Demand percentage (Demand) correspond.

HART systems also include the local configuration interface. If a Demand alarm exists, the STAT LED and the DEMAND LED are illuminated. This LED will blink if more than one status LED is illuminated.

If Demand is not displaying the correct value, the DCM-3 is not accepting the correct Demand signal.

CHECKING SHAFT POSITION

The output shaft position can be read as Position on the Online menu.

Does Position % match Demand %? The exactness of the match is controlled by the parameter Step Size (page 20). If they match, the DCM-3 is not running the motor because the signals appear to match.

If the signals match, the next question is whether Position % is correct for the actual output shaft position. Refer to OUTPUT SHAFT POSITION SENSING (page 26). The CPS-5 signal voltage as measured by the DCM-3 is available as PresCPS V in the PositionSensrSetup menu. The actual voltage can be measured with a voltage meter between test points TP4(+) and TP1(-). Refer to DCM-3 Test Points and Resistor (page 80).

POSITION AND DEMAND MISMATCH

If the shaft position and the Demand do not match and the motor is not running, then some factor is preventing the DCM-3 from running the motor. The HART interface provides extensive information for finding this factor.

The Status menu contains two parameters that summarize why the motor is not running: one parameter for RET and one for EXT. The parameter names are RET Inhibitors and EXT Inhibitors. If the parameter is 0 (has not bits set), the motor should run that direction. If the parameter is not 0, the DCM-3 will not try to run the motor that direction. The bits that show in the parameter are the reasons the motor is not running that direction.

INHIBITORS

Label	Cause of Motor Not Running
OverTrq/Thrust	Not active in Group 14
Balance	Demand indicates motor should not run this direction.
Stall	Stall.
Supervisory	The DCM-3 is initializing.
Switch Block	Not used in Group 14 actuators
Bad Pos Sig	The Position signal from the CPS-5 is not acceptable
Bad Dem Sig	The applied Demand signal appears invalid.
Local Cal	A local configuration interface button is pressed.

If the inhibitor parameter is 0 but the motor is not running, power to the motor is being blocked by something over which the DCM-3 microcomputer has no control. Possibility 1 listed below should lead to a Stall alarm (page 21). The other possibilities should create a Stop/Limit alarm (page 21).

1. The motor is stalled, and cannot travel. This condition is unlikely if the motor operated properly with the Handswitch. For more information on the Handswitch, refer to Checking Handswitch Operation (page 60).
2. The Handswitch or an Over-travel Limit Switch is preventing power from reaching the motor. Make certain the Handswitch is in AUTO. The Handswitch and the DCM-3 both use the same over-travel limits, so if the limits do not prevent Handswitch operation, they should not prevent DCM-3 operation.
3. Wire jumpers are missing from terminals F-N and terminals D-M on the field wiring terminal block. Most installations of Group 11 actuators with HART compatibility require these wire jumpers. Check the wiring diagram that came with the specific actuator.
4. The output section of the DCM-3 is not delivering power to the motor.
5. The DCM-3 fuse is cleared. This fuse is rated at more than twice the motor current, and the Beck motor has no significant inrush current. Therefore, only in very rare circumstances is the fuse cleared. These circumstances are generally wiring errors during customer installation. For the fuse location, refer to DCM-3 LAYOUT (page 16).

DCM-3 SERIAL INTERFACE Setup

Beck Configuration Port

Local configuration of the Beck actuator can be accomplished using Serial commands through the DCM-3 Serial port.

The Beck Digital Control Module (DCM-3) is equipped with a Serial interface which allows for direct communication with a computer. Using a standard DB9 to USB cable, connect the DCM-3 to the computer using the DCM-3's DB9 connector (see below for location) and one of the computer's USB ports. Note: If your computer is equipped with an active COM port, a DB9 to DB9 cable may be utilized. See below for part numbers of cables available from Beck.

Once connected, communication can be established between the DCM-3 and the computer using a terminal emulation program, such as HyperTerminal®. This method of communication will allow for configuration, calibration and verification of actuator DCM-3 settings without the use of custom software applications.

HyperTerminal® Software

HyperTerminal is the standard ASCII terminal emulation software provided with Microsoft® Windows®. If using HyperTerminal®, the following instructions will assist in setup. Note that some variation to these instructions may be necessary depending on the version of HyperTerminal® being used.

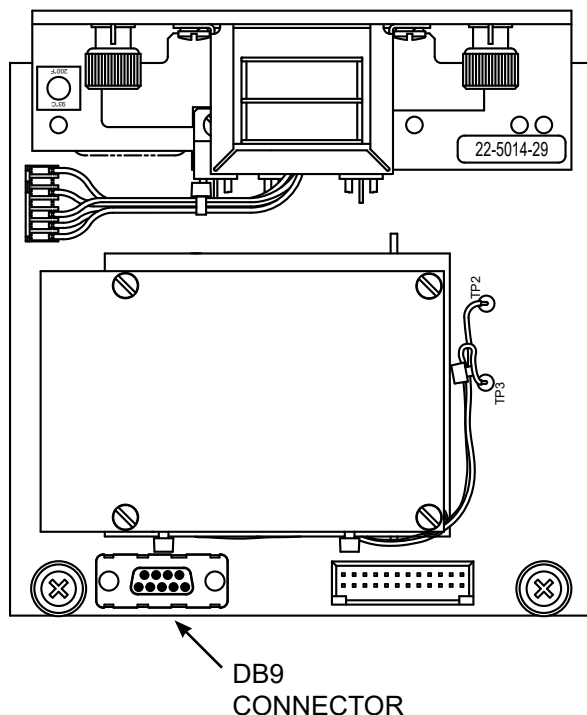

After connecting the DCM-3 to the (Windows®-based) computer, access HyperTerminal® by clicking first on "Start", then "Programs", then "Accessories", then "Communications", then "HyperTerminal". Double-click on the "Hypertrm.exe" icon to start the program. Once HyperTerminal® is running, it is necessary to set up a file with the proper settings to communicate with the DCM-3. Proceed as follows:

1. If prompted to install a modem, answer "no". Proceed to enter a name (e.g., "DCM-3") and select an icon (any will suffice) in the "Connection Description" box. Click the "OK" button.
2. The "Connect to" box should open next. At the bottom of the box, set the "Connect using" selection to the appropriate USB (or COM) port that has been connected to the DCM-3. Click the "OK" button.
3. The port properties box should open next; this is where the communication settings are established. The correct settings are:
 - a. Bits per second = "1200"
 - b. Data bits = "8"
 - c. Parity = "none"
 - d. Stop bits = "1"
 - e. Flow control = "none"
4. With the appropriate settings entered from Step 3, above, click "OK". Communications should now be enabled.
5. Press the "Enter" key twice. "OK" should be displayed indicating that HyperTerminal® is communicating with the DCM-3.

Beck Serial Communications Cables



DB9 to USB-A
P/N 20-0511-60



DB9 to DB9
P/N 20-0511-14

*Note cables may differ in appearance from depiction.

DCM-3 SERIAL INTERFACE Commands

Commands and Arguments

The interface provided by the Beck Configuration Port has a command – response format. Commands are typed through the terminal emulator into the DCM-3, and the DCM-3 responds to the commands.

As each letter is typed into the terminal emulator, that letter is sent to the DCM-3. The letters and numbers you see on the computer screen are not directly created by what has been typed, but are the characters sent back to the computer from the DCM-3. Therefore, if you see on the screen what you have typed, those characters have been sent to the DCM-3, have been recognized, and have been sent back to the computer screen. If you do not see what you have typed, the communication link is not fully operational.

After each recognized command, the DCM-3 responds with appropriate data, then sends a prompt sequence to alert the technician the DCM-3 is ready for the next command. If the Enter key is pressed without entering a command, the prompt sequence is sent back from the DCM-3 to indicate it is ready for a command.

If a command is entered in the wrong format, or if the command is invalid, and error code is reported before the new prompt is sent.

Commands can be used for a variety of functions including changing the operating configuration of the actuator, verifying operation settings and calibration, and accessing diagnostic information.

Commands exist in several formats. Some commands query settings, some commands can query or change parameters, and some commands create actions that can affect several parameters.

There are four different types of commands:

1. Dual-purpose commands. These commands can be used to either modify DCM-3 configuration settings or display the settings already set in the DCM-3. In order to set or make a change to the settings, the command requires an argument. Argument is used to identify a characters typed-in after the name of the command, but before the enter key is pressed. If the command is being used for display purposes only, the argument is omitted. Examples of these commands include "stallprot" and "demlos".
2. Display only commands. These commands are used to display diagnostic or operating information like present signal values. No arguments are required. Examples include the "stat" command and the "signals" command.
3. Set only commands. These commands serve only to make a parameter change. Typically, they apply to the actuator calibration. This type of command requires an argument, but unlike dual-purpose commands, they require an argument. Examples include the "trimdem4 mA" and "trimfdbk20mA" commands.
4. Execute action commands. These commands serve to reset, enable or disable features. Entering these commands produces an immediate action. Examples include the "reset" and "restore" commands. These commands require arguments to make certain the command was not entered by accident.

The available commands are listed on page 80. Each is described in more detail on the following pages. The command description explains the use or uses of the command, while the argument column describes the applicable arguments.

In the command tables, arguments are denoted as n. Note that the commands described as "sets and/or displays" signify dual purpose commands that can be used with or without an argument for setting or verifying configuration settings.

DCM-3 SERIAL INTERFACE Commands

BCP COMMANDS

The following is a list of serial commands available through the DB9 interface.

General Configuration Commands (page 71)

alarmout
 alarmoutmask
 configformodel
 drvdir
 limitalarm
 opmode
 restoremodes
 sernum
 stallprot
 stalltime
 stepsize

HART® Configuration Commands (page 72)

harttype
 polladdr

Demand Characterizer Commands (page 72)

charclear
 charlist
 charset
 demfunc

Demand Signal Commands (page 73)

dem0pctma
 dem100pctma
 trimdem4 mA
 trimdem20 mA
 demlos
 demlogstp
 demlogstp delay

Output Shaft Position Sensing Commands (page 74)

cpsrotation
 cpsvat0pct
 posisd
 posisp
 travel

Feedback Signal Commands (page 75)

fdbk0pctma
 fdbk100pctma
 fdbkfunc
 trimfdbk4 mA
 trimfdbk20mA
 iomode

Thrust Sensing Commands (not active in Group 14)

Diagnostic and Information Commands (page 76)

codes
 reset
 signals
 stat
 temperature
 un stall

General Configuration Commands

Command	Description	Argument n and Information
alarmout n	Sets and/or displays the polarity of the alarm output solid state relay.	n = "0": Open on Alarm n = "1": Closed on Alarm
alarmoutmask n	Sets and/or displays the hexadecimal mask of which alarms cause the alarm output relay to open or close.	n = bit-wise OR-ed, 32-bit hexadecimal value, high bits indicate alarm will change output relay Default value = 0xFFFFFFFF, which means all alarms cause the relay to change state.
configformodel n	Sets the DCM-3 configuration for position sensing voltage range to the values appropriate for the actuator model and CPS-5 output signal.	n must equal "1" for the command to execute.
drvdir n	Sets and/or displays the actuator output shaft direction resulting from an increasing Demand signal.	n = "0": Extend on increasing. n = "1": Retract on increasing.
limitalarm n	Sets and/or displays a modifier to the Stop/Limit alarm.	n = "0": "mute" corresponds to "Accept" for FF and HART. n = "1": "always" corresponds to "Alert" for FF and HART.
opmode n	Sets and/or displays the mode that controls the Demand signal source. This mode selects analog or digital control.	n = "0": "follow" is analog Demand. n = "1": "hold" is digital Demand. n = "2": retract. n = "3": extend. n = "4": stay. n = "5": stop.
restoremodes n	The DCM-3 configuration returns to the original factory settings.	n must equal "1" for the command to execute.
sernum n	Sets the serial number of the actuator in which the DCM-3 is installed. Model number information used by the DCM-3 is derived from the serial number.	n = serial number.
stallprot n	Sets and/or displays the enabled/disabled value for Stall protection.	n = "0": disabled. n = "1": enabled.
stalltime n	Sets and/or displays the time allowed for the actuator to reach its Demand target.	n = time in seconds. Time to stall is configurable from 30 to 450 seconds. The default value is 300 seconds.
stepsize n%	Sets and/or displays the size (in %) of one incremental movement of the output shaft. Whether setting or displaying, include the % symbol. Without the % symbol, the unit of measure is inches.	n = step size in %. The minimum value that can be entered is "0.10"; the factory setting is "0.15". The maximum value is "2.50". Without the % symbol, the unit of measure is inches.

DCM-3 SERIAL INTERFACE Commands

HART® Configuration Commands

Command	Description	Argument n and Information
harttype n	Sets and/or displays the DCM-3 HART device type. DD number 239 is the proper DD. The others are for temporary use with older DD's if the new DD is not available. If the DCM-3 is configured for Foundation Fieldbus, the device type must be set to 239.	n = "1": ESR-D n = "10": BECK-DCM n = "239": BECK-MK2
polladdr n	Sets and/or displays the polling address used by the HART host to find individual devices if the HART bus has more than one device. Unless multiple HART devices are connected in parallel on a single bus, the polling address should be set to 0. If the DCM-3 is configured for Foundation Fieldbus, the polling address must be set to 0.	n = the polling address, a value between 0 and 15.

Demand Characterizer Commands

Command	Description	Argument n and Information
charclear n	Sets the status of a characterizer node to "unused." Any nodes with higher node numbers are also set to unused.	n = node number to make unused
charlist n	Displays the X-values and Y-values in percent of the nodes of the characterizer curve. The argument is which node to use to begin the display. This node number does not change which nodes are active.	n = node number to begin display OR n = "all": display all values
charset n	Sets the X-values and Y-values of a specific node of the characterizer curve. Requires a set of three arguments separated with commas.	n1, n2, n2 = node number to modify, X-value in percent, Y-value in percent.
demfunc n	Sets and/or displays the Demand signal characterization function.	n = "0": Linear n = "1": Square Root n = "4": Special Curve n = "5": Square

Demand Signal Commands

Command	Description	Argument n and Information
dem0pctma n Used with analog Demand signals.	Sets and/or displays the Demand signal value that corresponds to 0%.	n = the Demand signal as a decimal in mA. The minimum acceptable value is 0.50. The maximum acceptable value is 100% Demand less 4.00. For example, if the 100% Demand signal is 20.00, then the 0% Demand signal must be 16.00 or less.
dem100pctma n Used with analog Demand signals.	Sets and/or displays the Demand signal value that corresponds to 100%.	n = the Demand signal as a decimal in milliamps. The minimum acceptable value is the 0% Demand plus 4.00. For example, if the 0% Demand signal is 4.00, then the 100% Demand signal must be 8.00 or greater. The maximum acceptable value is 21.00.
trimdem4 mA 4 Used with analog Demand signals.	Trims the Demand analog-to-digital sensing circuit to be accurate at 4 mA. This command should only be used when the Demand signal at the actuator is exactly 4 mA. Trim is factory set. Recalibration should not be necessary.	Trim can only be performed at 4 mA.
trimdem20 mA 20 Used with analog Demand signals.	Trims the Demand analog-to-digital sensing circuit to be accurate at 20 mA. This command should only be used when the Demand signal at the actuator is exactly 20 mA. Trim is factory set. Recalibration should not be necessary.	Trim can only be performed at 20 mA.
demlos n Used with analog Demand signals.	Sets and/or displays the Demand signal threshold below which the DCM-3 recognizes that the signal is lost. The threshold is entered as a value in mA. This command also sets and/or displays the action initiated by the actuator during LOS (Loss Of Signal). LOS action options are "sip" (stay in place) or "gtp" (go to position). Demlos always reports both settings, but only sets one argument at a time. Demlos must be used twice to set the threshold and action.	n = the Demand signal in mA below which LOS occurs. A typical value for a 4 mA–20 mA system is 3.20. — OR — n = "sip", "gtp" or "pat". Mode "pat" acts the same as Stay in Place, but suppresses the alarm. This is used in some pulsed applications.
demlosgtp n Used with analog Demand signals.	Sets and/or displays the position to which the actuator will run upon loss of the Demand signal (LOS). This command has no effect if the actuator is set to "sip" (stay in place).	n = the desired position of the actuator expressed as a percentage of actuator travel. For example, if the desired go-to-position is 50%, then n = 50.00.
demlosgtp delay n	Sets the time delay in seconds before the actuator will move to the position set in "demlosgtp". Entering this command without an argument will return the present gtp and delay settings.	n = time delay in seconds. Acceptable values are 0 (default) to 25.5.

DCM-3 SERIAL INTERFACE Commands

Output Shaft Position Sensing Commands

Command	Description	Argument n and Information
cpsrotation n	Sets and/or displays the DCM-3 parameter for the expected output shaft direction for an increase in CPS-5 signal. This should be set to retract for increasing signal for all non-custom applications.	n = 0: Retract increasing n = 1: Extend increasing
cpsvat0pct n	Sets and/or displays the DCM-3 voltage setting used to determine 0% signal from the CPS-5. The CPS-5 calibration is defined by the actuator model. Refer to CPS-5 Calibration.	n = the desired length of travel in degrees. This value cannot exceed the maximum output shaft rotation of the actuator.
posisd n	Sets CPS Zero% through an alternate method. Use this command if the exact CPS-5 signal voltage at 0% shaft position is not known. The output shaft can be positioned to 0%, then execute this command with an argument of 0. CPS Zero% will be adjusted to match the CPS-5 signal voltage at that point. Travel does not change, so the 100% point will change.	n = the present actuator position in angular degrees.
posisp n	Sets Travel through an alternate method. Use this command if an exact angular Travel is not known. The output shaft can be positioned to 100%, then execute this command with an argument of 100. Travel will be adjusted to the correct number of degrees for this to be 100%. The 0% point does not change, and therefore the 0% point should be set first. Refer to OUTPUT SHAFT 0% POSITION for more information on the 0% point.	n = the present position in angular degrees.
travel n	Sets and/or displays the number of degrees that represents 100% travel. This command does not shift the 0% position. When increasing travel from a reduced travel setting, the 0% position might have to be changed first in order to keep the travel with the acceptable end points. The end points are defined by the CPS-5 voltage range.	n = the desired length of travel in degrees. This value cannot exceed the maximum output shaft rotation of the actuator.

Feedback Signal Commands

Command	Description	Argument n and Information
fdbk0pctma n Used with analog Feedback signals.	Sets and/or displays the mA value of the Feedback signal that represents the 0% output shaft position. May also be set for decreasing direction of Feedback.	n = the desired Feedback signal in mA at 0% output shaft position . The minimum value is 3.00 and the maximum value is at least 4.00 less than the Feedback signal value for the 100% output shaft position.
fdbk100pctma n Used with analog Feedback signals.	Sets and/or displays the mA value of the Feedback signal that represents the 100% output shaft position. May also be set for decreasing direction of Feedback.	n = the desired Feedback signal in mA at 100% output shaft position. The minimum value must be at least 4.00 greater than the Feedback signal value for the 0% output shaft position. The maximum value is 21.00.
fdbkfunc n Used with analog Feedback signals.	Sets and/or displays the curve used to calculate the Feedback signal.	n = "0": Linear (curve disabled) n = "1": Inverse Demand (curve enabled)
trimfdbk4 mA n Used with analog Feedback signals.	Trims the Feedback signal at 4 mA. The Feedback sourcing circuit is factory calibrated and normally does not require recalibration.	n = the present Feedback signal from the DCM-3 as measured in mA.
trimfdbk20mA n Used with analog Feedback signals.	Trims the Feedback signal at 20 mA. The Feedback sourcing circuit is factory calibrated and normally does not require recalibration.	n = the present Feedback signal from the DCM-3 as measured in mA.
iomode n Used with analog Feedback signals.	Sets and/or displays the function of a DCM-3 connector pin. The DCM-3 pin that is used to source the Feedback signal can instead be used to power an output shaft position-sensing potentiometer on models of Beck actuator that do not use the CPS-5. If the pin use parameter is not set to Feedback, the Feedback circuit is disabled. If the pin use parameter is set to Pot, 5 Vdc is output from this pin to power the potentiometer. Setting the parameter to None disables the Feedback and the potentiometer supply.	n = "0": None n = "1": Feedback enabled n = "2": Potentiometer power enabled

DCM-3 SERIAL INTERFACE Commands

Diagnostics and Information Commands

Command	Description	Argument n and Information
codes	Displays the present status of motor power inhibitors, pushbutton status, LED status, the process variable inside/outside limits status, analog signal measurement status, discrete input status, and alarm status. All information is in Bit-wise ORed hexadecimal notation. Each status word is decoded onscreen for convenience.	No argument.
reset n	The microcomputer performs the same reset sequence as when power is removed and reapplied.	n must equal "1" for the command to execute.
signals n	Displays the present DCM-3 readings of four signals: Position signal from CPS-5 Demand (analog systems) Feedback (analog systems) Torque.	If no argument, the signal readings are returned. n = "all": an extended set of data is returned.
stat	Displays information on the status of the actuator, including: Time / Date Demand Position Error (Demand minus Position) Step size Dead band Motor Status Motor Run Time Line Frequency Motor Starts Motor Reversals/Stalls Number of Over-Torque conditions Positive & Negative Peak Torque (%) CW and CCW Inhibitor Status Alarms	No argument.
temperature n (page 28)	Displays three values describing the ambient temperature in the actuator. Low extreme, present, high extreme. Can also change the temperature units.	If no argument, the temperatures are displayed in the active units. n = "F": change units to Fahrenheit n = "C": change units to Celsius
unstall (page 29)	Resets the Stall Protection alarm to restore power to the motor. If the motor is still physically stalled, the Stall Protection alarm will recur.	No argument.

MAINTENANCE Routine / Component Replacement

The Beck Group 14 actuator requires only minimal routine maintenance. Periodic visual inspections are recommended to verify that the connection to the valve is intact and operating normally. If vibration is present, check the electrical terminal connections and other hardware for tightness.

LUBRICATION

Periodic lubrication is not required on Beck actuators. However, during major maintenance outages, it is recommended that older actuators should be inspected to ensure that the gearing is not worn or damaged.



CAUTION

Before removing the gear housing assembly, block the valve stem to prevent the gear train from moving when the housing assembly is removed.

To inspect or lubricate the output gear only, remove the cover plate (1/2" bolt heads) on the side opposite the motor. The output gear is not field replaceable.

To inspect all the gears, first remove the motor from the housing, following the instructions on page 78. Then, remove the housing assembly from the body (1/2" bolt heads). Clean all parts thoroughly, removing as much old lubrication as possible. Examine the gear teeth for signs of excessive wear, scoring, or other damage. Check for excessive free play of gears on shafts. The assembly is not field repairable and should be returned to the factory if excessive wear is noted.

Before reassembly, recoat the teeth with a heavy layer of Fiske Lubriplate GR-132 or equivalent. GR-132 is an E.P. grease with polymer additives. To reinstall the gear housing, carefully position the housing on the body's alignment pins. Replace the bolts and tighten to 10 lb-ft (13.5 N•m).

Reattach the motor per the instructions on page 78.

This section covers replacement of many components of the Group 14 actuator. Note that some components are not field repairable.

If it should ever be necessary to replace the output gear, shaft, or output shaft bearings, a major overhaul is required and the actuator should be returned to the factory.

GASKETS

During routine service, inspect the gaskets and O-rings for wear or damage. In order to protect internal components, worn or damaged gaskets and O-rings should be replaced.

To remove the main gear cover, terminal compartment, or the motor gaskets, scrape all of the old adhesive and gasket material from the body housing and cover. Cement the new gasket to the actuator body using a gasket cement such as 3M #847 Rubber and Gasket Adhesive, or equivalent.

O-ring seals are used between the body and the top and bottom bearing plates. Before installing a new O-ring, lubricate it with light machine oil.

The large top cover is sealed with rubber foam gasket material, 5/16" (8 mm) in diameter. To replace this material, scrape the old gasket material and cement from the groove. Cement the new foam gasket into the groove with 3M #847 Rubber and Gasket Adhesive, or equivalent. Cut the ends of the material on an angle and cement them together with this same adhesive.

SEALS

Worn or damaged output shaft and motor shaft seals should be replaced to prevent damage to internal bearings and drive parts.

To remove the shaft seal, push the blade of a small screwdriver along the shaft and under the seal lip. CAUTION: The seal is approximately 1/4" wide. Do not force the screwdriver blade beyond the width of the seal; damage to the shaft bearing could result. Pry up on the seal and force it out of the housing. Clean the shaft and housing and press in the replacement seal with the closed side facing outward.

BEARINGS

There are some field replaceable bearings in the Group 14 actuator. Consult the factory for details.

MAINTENANCE Component Replacement

MOTOR

The control motor is not field-repairable. Disassembly of the motor will result in a loss of torque that can only be restored by returning the motor to the factory for remagnetizing.



CAUTION

Before removing the motor assembly, while the process is running, block the valve stem to prevent the gear train from moving when the motor is removed.

To remove the motor, first disconnect the motor wires in the terminal compartment of the actuator. The wiring is under the terminal board. Remove the black wire from the terminal post, cut the green motor wire near the green-yellow-red butt joint and disconnect the red wire from the re-green-blue butt connection. Remove the three 10-32 socket head cap screws that secure the motor. Carefully slide the motor out of the actuator body.

To install the motor, insert the three-wire sleeve through the wire hole in the motor mount and into the terminal compartment. Carefully slide the motor into the actuator body, rotate the motor shaft if necessary to engage the pinion with the first combination gear. Install the motor mounting hardware (10-32 screws at 20 lb-in (2.26 N•m)). Reconnect the motor wires.

NOTE: 14-100 models with 4 and 8 second timing have a spacer between the motor and gear module.

MOTOR RESISTOR AND CAPACITOR

The motor resistor assembly and capacitor are located in the top compartment beside the Calibar. To replace a resistor or capacitor, remove the top cover (15/16" bolt head). Remove the existing part and transfer the wires one at a time to the replacement part. Inspect the top cover gasket and replace if necessary. Replace the top cover. Tighten the top cover bolt just enough to compress the O-ring seal.

OVER-TRAVEL LIMIT AND AUXILIARY SWITCHES

Complete switch assemblies may be replaced. It is not possible to replace individual switches. To replace switch assemblies, remove the top cover (15/16" bolt head). Remove the #6-32 socket head cap screws holding the switch assembly to the plate.

Transfer the wires one at a time to the replacement assembly using the push-on lugs provided. Install the replacement assembly and note that it rotates around one screw to permit an adjustment of the cam-to-roller spacing and switch operating point. To properly set the switch, use a .030" (.76 mm) shim between the cam and switch lever and loosely position the switch assembly so that the switch is just actuated. The switch lever should be on the low or minimum radius portion of the cam when setting the switches. **DO NOT** overstress the switch lever. Tighten both screws to 10 lb-in (1.13 N•m) torque and remove the shim. When properly adjusted, the switch lever should remain in contact with the cam throughout the actuator travel.

ADDING SWITCHES

It is possible to add two additional switches to an actuator in the field. Consult the factory, giving the actuator model and serial number so that a correct list of parts required may be supplied to you.

Remove the top cover (15/16" bolt head). Install wiring onto the switch push-on lugs and route the wires into the actuator terminal area. Remove the terminal cover and solder wires to the underside of the terminal assembly according to the wiring diagram included with the new switch assembly. Install the new switch assembly and adjust according to the instructions above. See table on page 81 for switch assembly part numbers.

SELF-LOCKING MECHANISM (SLM)

In normal service, the SLM friction surface should not require replacement; however, a combination of excessive modulation and load can cause wear to the SLM mechanism. If the SLM has been damaged, rebuild kits are available (see table at right).

SLM Rebuild Kits typically consist of a spring, spring pin, thrust bearing, pinion, steel balls, locking disc, steel shims, control motor gasket, terminal joints, friction material liner and instruction sheet.

See the figure at right for identification of typical SLM components.

SLM KIT PART NUMBERS

Motor Part Number	SLM Rebuild Kit	Instruction Sheet
	GL181-134	
20-2702-31	12-8067-19	80-0016-09
20-2703-31	12-8067-19	80-0016-09
20-2703-34	12-8067-20	80-0016-09

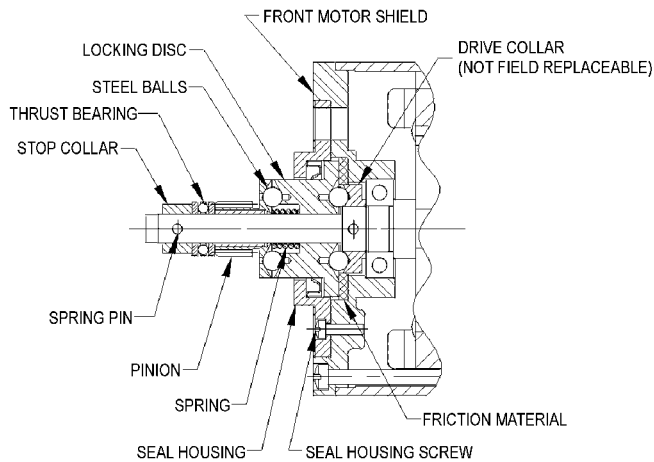

SLM Detail

Handswitch

To replace the Handswitch, remove the terminal cover, DCM-3 board and DCM-3 bracket. Clip the five wires from the old Handswitch. Remove the knob and the nut under the knob to remove the switch. Install the new Handswitch as shown in the figure below. Splice the wires color for color. Replace the DCM-3 bracket, board and the terminal cover. Torque bolts to 10 lb-ft (13.5 N•m).

NOTE: The AUTO position on the Handswitch knob must be straight up when the switch is fully clockwise. Handswitch part number 20-3300-27.

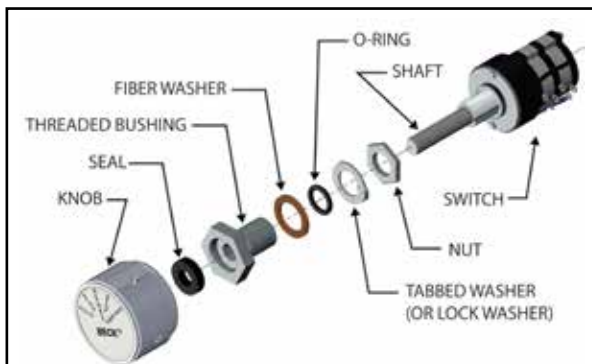

Handswitch Detail

DCM-3

Field service of the DCM-3 board is not recommended. The factory maintains a stock of replacement boards for immediate shipment. To replace the DCM-3 board, remove the terminal compartment cover (1/2" bolt heads). Loosen the four captive thumb screws holding the board to its mounting pads. Note the "L" shaped mounting bracket on the end of the board. To remove the board, pull the mounting bracket away from its mating surface with a gentle rocking motion. See image below.



DCM-3 Replacement

To install a DCM-3 board, lightly press the board connector into its receptacle until the mounting bracket is flush with its mounting surface. Tighten the four captive thumb screws and replace the compartment cover. Torque cover bolts to 10 lb-ft (13.5 N•m).

CPS-5

Field repair of the CPS-5 assembly is not recommended. The factory maintains a stock of replacement assemblies for immediate shipment. If it is necessary to replace the CPS-5, replace both the rotor and stator / circuit board assembly. When returning the CPS-5 to the factory for service, include the rotor and stator / circuit board assembly. Do not separate the stator or circuit boards from their mounting plates. The rotor should be held inside the stator with rubber bands for protection during shipment.

MAINTENANCE Component Replacement

To remove the CPS-5:

1. Run the actuator to its midpoint of travel with the local Handswitch. (If the standard rotation of 100° has been reduced to 80°, the midpoint of travel is 40°.)
2. Disconnect 120 Vac power to the actuator. Remove the terminal, DCM-3 compartment and control end covers (1/2" bolt heads).
3. Record the wire colors on the terminal block of the CPS-5 (see illustration, upper right), then disconnect the wires. The terminals are spring-loaded. To remove a wire, press the tip of a small screwdriver into the slot at the top of the small lever. Push down to open the spring-loaded contact and release the wire.
4. Pull the wires from the transformer (see illustration, middle right) back through the wire hole in the CPS-5.
5. Loosen and remove the 3 hex studs that clamp the CPS-5 in place. Ensure that the inboard hex stud is not loosened as the outboard stud is loosened.
6. Slide the CPS-5 stator assembly off the three mounting bolts.
7. Note the position of the rotor clamp, then loosen the rotor clamp screw and remove the rotor from the shaft.

To install the new CPS-5:

1. Remove the rotor from the replacement CPS-5 assembly. Slide the rotor, clamp end first, onto the control shaft as close to the mounting plate as possible. Leave the clamp loose. Position the clamp in the same general location as the one removed previously.
2. Slide the new CPS-5 assembly over the studs and rotor. Replace the hex nuts but do not tighten. Carefully slide the rotor back into the CPS-5 assembly. Twist the rotor while sliding to prevent damage to the assembly. Tighten hex nuts to 5 lb-ft (6.8 N•m).
3. Thread the wires through the wire holes in the CPS-5 and reconnect them to the transformer and terminal block.
4. Restore 120 Vac power to the actuator and connect a meter to the output.
5. Insert a 0.031" feeler gauge between the rotor clamp and stator. Position the clamp 0.031" from the stator.
6. Rotate the rotor (only a minor adjustment should be necessary) on the control shaft until the output voltage measured across TP4 and TP1 (see illustration at right) reads 50% (approx. 3 volts) of the signal span. Tighten clamp to 5 lb-in (0.56 N•m) torque.
7. Perform a position calibration procedure.

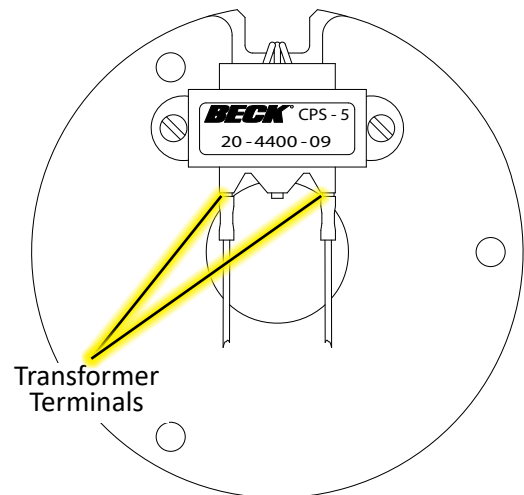
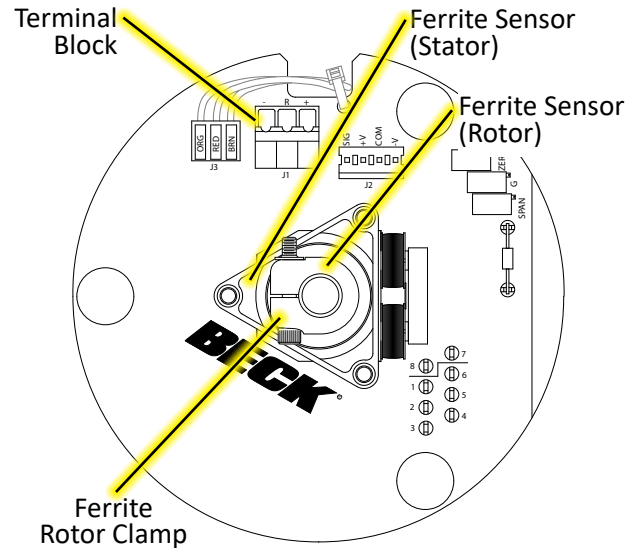

CPS-5 Components

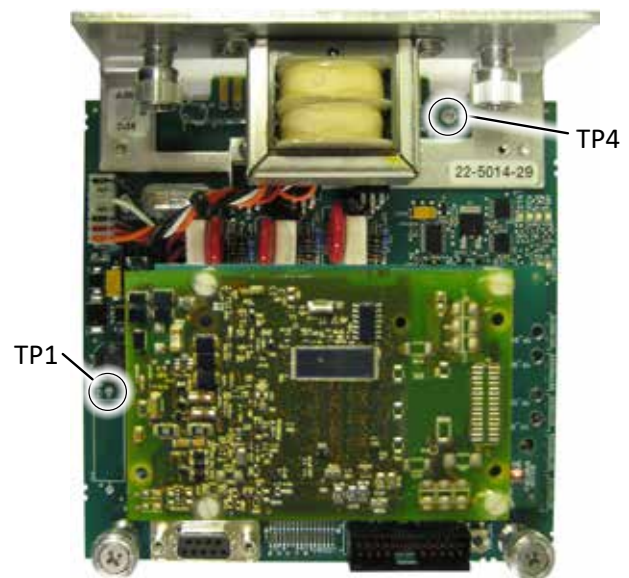

Location of DCM-3 Test Points TP1 & TP4

APPENDIX Spare Parts

RECOMMENDED SPARE PARTS

It is recommended that certain replacement parts be stocked for quick availability in the event that service of your Beck actuator is required. The types of parts are listed in the spare parts table below.

HOW TO ORDER SPARE PARTS

Select the needed parts from the spare parts list given below. Specify the actuator's model / serial number (example: 14-109-031891-01-02) given on the nameplate to allow the factory to verify the part selection. Parts may be ordered by mail, telephone or fax, with the confirming order sent to the factory (see back cover).

RECOMMENDED SPARE PARTS

DESCRIPTION	PART NUMBER
DCM-3 board	22-5014-29
Fuse, 7A, 125V (For use on DCM-3)	11-1372-26
CPS-5 assy.	20-4400-09
Fuse, 0.8A, 250V (Model 14-10_, 240V)	11-1370-16

DESCRIPTION	PART NUMBER
Overtravel limit switch assy. 4 switches (RET, EXT, S1, S2)	20-3202-20
Auxiliary switch assy. 2 switches (S3-S4)	20-3202-21
Motor assy., Capacitor, Resistor	See Below
Gasket set	20-3110-13

MOTORS, CAPACITORS, AND RESISTORS

Model No.	Motor				Capacitor		Resistor		Use Only With Timing ...	
	Part No.*	Current (Amps at 120 Vac, 60 Hz ^c)	Torque (N•m)	RPM	Freq. (Hz)	Part No.	Value (µf)	Part No.		Value (Ω)
14-109	20-2702-31	.44	1.5	72	60	14-2840-16	5	20-1971-13	220	10 sec. or higher
					50	14-2840-19	7	20-1971-13	220	10 sec. or higher
	20-2703-31	.72	3.0	72	60	14-2840-05	8	20-1971-12	110	10 sec. or higher
					50	14-2840-30	13	20-1971-12	110	10 sec. or higher
	20-2703-34**	.72	3.0	72	60	14-2840-05	8	20-1971-12	110	8 sec. or higher
					50	14-2840-30	13	20-1971-12	110	8 sec. or higher

* Motor replacement part numbers will include the suffix, "-KIT"; e.g., 20-2702-31-KIT.

** It is necessary to install a gear housing spacer with this module.

GEARS

MODEL NO.	SPUR GEAR RATIO / 1	NOMINAL SPEED sec./in. (sec./cm)		GEAR HOUSING ASSEMBLY
		60 Hz 72 RPM	50 Hz 60 RPM	
14-109	4.14	4 (1.6)	5 (2.0)	10-6670-36
	7.90	8 (3.1)	10 (3.9)	10-6670-26
	10.65	11 (4.3)	13 (5.1)	10-6670-24
	15.70	16 (6.3)	19 (7.5)	10-6670-13
	25.90	27 (10.6)	31 (12.2)	10-6670-23
	45.80	48 (18.9)	57 (22.4)	10-6670-07

APPENDIX Components

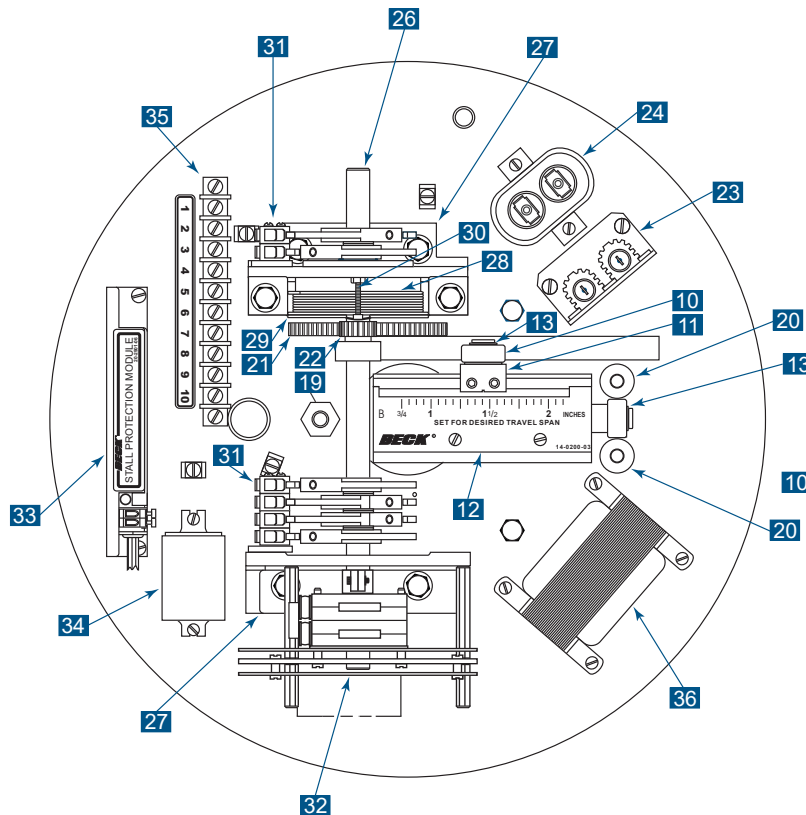

PARTS FOR MODEL 14-109 CONTROL ASSEMBLY AND DRIVE TRAIN

ITEM NO.	DESCRIPTION	ITEM NO.	DESCRIPTION
1	Top bearing plate with bushing and seals	18	Top bar
2	Seal for top bearing plate	19	Hex stud
3	Bottom bearing plate with bushing and seals	20	Guide bar (2)
4	Seal for bottom bearing plate	21	Sector-level gear assembly
5	Maingear assembly	22	Pinion
6	Mainshaft bearing	23	Resistor; select from table on p. 81
7	Cover plate	24	Capacitor; select from table on p. 81
8	Cover plate gasket	25	Tight-sealer
9	Shaft assembly	26	Shaft
10	Ball bearing (2)	27	Bracket (2)
11	Calibar slider	28	Spring
12	Calibar index	29	Mandrel
13	Retaining ring (2)	30	Switch shaft indicator
14	Motor assembly; select from table on p. 81 (sold only as complete assembly)	31	Switches; see table on p. 81
15	Gear housing assembly; select from table on p. 81 (sold only as complete assembly)	32	CPS
16	Top cover with gasket	33	Double-pole, double-throw relay (optional)
17	Top cover bolt	34	Auxiliary terminal strip
		35	Transformer (w/ fuse, if 240V model)

Note: To ensure exact replacement parts, include all nameplate data of the Beck actuator with the order.

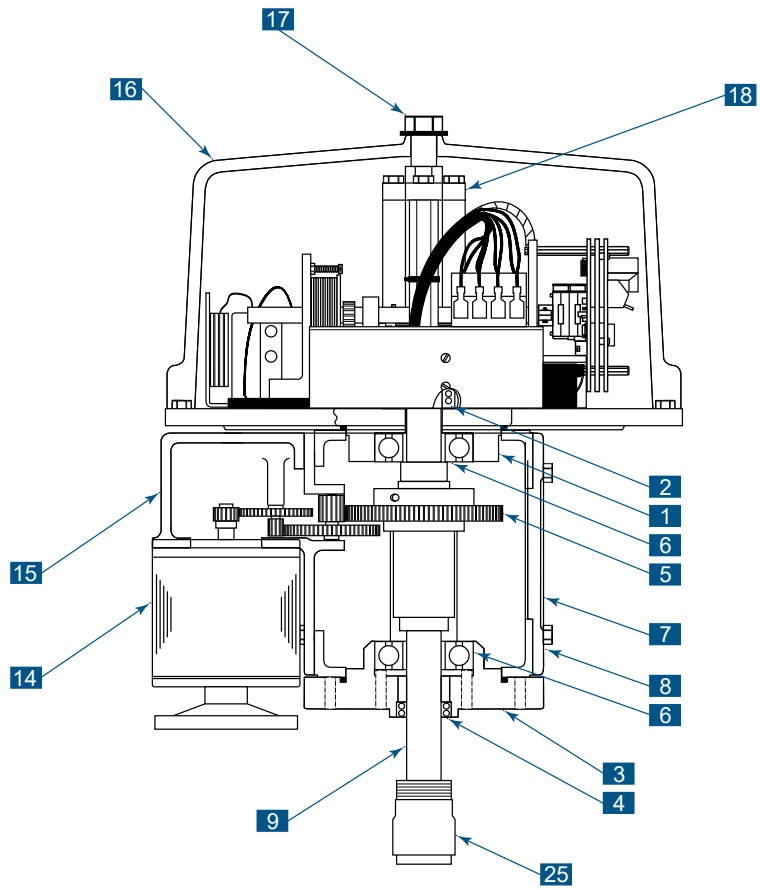

CONTROL ASSEMBLY AND DRIVE TRAIN

INDEX

Calibration Priority	32	Specifications, general	3
Communication Overview		Specification writing	85
Analog Control	12	Stall protection and annunciation	21
Foundation Fieldbus	11	Start-up instructions	14
HART	12	Stop/Limit indication	20
Component Replacement	77	Storage information	8
Components	82	Switch Adjustments	33
Control End	32	Switches	33
CPS-5 Calibration	32	Table of contents	2
DCM-3 Configuration	20	Temperature	6
DCM-3 Features	16	Troubleshooting Electronics w/ Foundation Fieldbus	62
Foundation Fieldbus Parameters	50	Troubleshooting Electronics w/ HART	66
Foundation Fieldbus Transducer Block	52	Troubleshooting, Local Interface	61
Gear Options	81	Unpacking	8
General Specifications	3	Valve Installation	9
Handswitch	15	Warranty	85
Handwheel	15	Wiring Connections	10
HART Menu Tree, DCM-3	37		
HART Menus, DCM-3	36		
HART Messages, DCM-3	46		
HART Parameters, DCM-3	44		
Maintenance	77		
Mounting	9		
Operation			
Parallel Connected	13		
Series Connected	13		
Operation, Modes of	15		
Outline Dimension Drawings	7		
Serial Interface Commands, DCM-3	69		
Serial Interface, DCM-3	68		
Services	85		
Service, How to Obtain	85		
Setting Auxiliary Switches	34		
Setting Over-travel Limit Switches	34		
Site surveys	85		
SLM	3, 78		
Spare Parts	81		

SERVICES

PRODUCT DEMONSTRATIONS

Each of Beck's Sales Engineers has access to a complete set of actuator models so that he can demonstrate virtually any of their features at your location. In order to arrange to see a Beck actuator in your plant or office, contact Beck's Sales Department.

SITE SURVEYS

Beck Sales Engineers are available to discuss your process control requirements. Often a visit to your location is the best way to gain a thorough understanding of your needs, in order to meet them most accurately and completely.

Mounting hardware, torque requirements, linkage, control signal information, and optional equipment can be analyzed most effectively at the work site. Beck's analysis at the job site can help ensure that specifications are accurate, especially in the case of complex applications.

APPLICATION REVIEWS

By sharing your needs with a Beck Sales Engineer you can take advantage of the best application advice for the type of control you

need. This review will yield a better understanding of the versatility of Beck actuators for your installations, as well as complete details on options and accessories to make the process as effective as possible.

SPECIFICATION WRITING

Beck provides specification writing assistance in order to help you specify and order the right actuators for your applications. Beck Sales Engineers will work with you to make it easier for you to obtain the proper equipment and give you confidence that no details are overlooked.

HOW TO OBTAIN SERVICE

Factory repair of actuators or subassemblies is available for both normal and emergency service. To assure prompt processing, contact the factory to receive a Returned Material Authorization (RMA) number. If a repair estimation is desired, please send the name and phone number of your contact for service authorization. It is helpful to include a description of the work desired with the shipment or, in the event of a problem, the malfunction being experienced.

THREE YEAR LIMITED EQUIPMENT WARRANTY

Beck warrants to Buyer that: (i) for a period of 3 years from the date of shipment, the Equipment manufactured by Beck shall materially conform to Beck's published standard specifications in effect as of the date of shipment; and (ii) the Beck Equipment will be free from defects in materials and workmanship. This warranty does not apply to normal wear and tear, or where Beck Equipment failure is a result of improper installation, improper storage, misuse or improper maintenance, or water ingress related to Buyer or its agents failing to apply the stated torque requirements to fasteners when attaching covers or failing to replace temporary conduit plugs as stated in the installation instructions, or entry through conduits.

During the Limited Warranty Period, Buyer shall notify Beck of any alleged warranty claim within 30 days from the date Buyer discovers, or upon reasonable inspection should have discovered, such alleged claim (but in any event prior to the end of the Limited Warranty Period), and Buyer shall return the Beck Equipment in question, at Buyer's expense, to Beck for evaluation, in compliance with the terms stated in the "Return of Equipment" article in the Sales Contract. If Beck determines that the Beck Equipment fails to conform to the limited warranty, then, at Beck's sole discretion and its expense (subject to Buyer's conformity with the warranty), Beck will either: (i) repair or replace the Beck Equipment, without charge, at Beck's factory, or (ii) refund the purchase price of such Beck Equipment, less any applicable discounts, rebates, or credits. In no event will Beck's liability exceed the contract price actually paid for such Beck Equipment subject to a warranty claim. Beck makes no warranty, express or implied, with respect to any Buyout Item. This limited warranty is not transferable or assignable to any transferees of the Beck Equipment.

THIS WARRANTY IS EXPRESSLY IN LIEU OF ANY OTHER EXPRESS OR IMPLIED WARRANTY, INCLUDING IMPLIED WARRANTIES OF MERCHANTABILITY AND FITNESS FOR A PARTICULAR PURPOSE, AND ALL OTHER OBLIGATIONS OR LIABILITIES OF BECK. BUYER ACKNOWLEDGES THAT: (i) BECK HAS MADE NO INDEPENDENT INVESTIGATION OF THE SUITABILITY OF THE EQUIPMENT FOR BUYER'S INTENDED USE OR EXISTING SYSTEMS; AND (ii) BUYER HAS NOT RELIED UPON ANY REPRESENTATION OR WARRANTY MADE BY BECK OR ANY OTHER PERSON ON BECK'S BEHALF, EXCEPT AS SPECIFICALLY PROVIDED IN THE SALES CONTRACT. THIS SECTION SETS FORTH BUYER'S SOLE AND EXCLUSIVE REMEDY FOR ANY BREACH OF THE LIMITED WARRANTY SET FORTH IN THIS SECTION.

NOTES

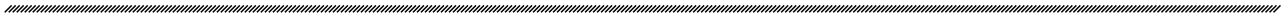

A 100% EMPLOYEE OWNED COMPANY

BECK

~ founded 1936 ~

SINCE 2021



HAROLD BECK & SONS, INC.

11 TERRY DRIVE • NEWTOWN, PENNSYLVANIA 18940 • USA

PHONE: 215-968-4600 • FAX: 215-860-6383 • E-MAIL: sales@haroldbeck.com

www.haroldbeck.com

Made in USA

