



INSTRUCTION MANUAL

For actuators equipped with DCM-3
models built after July 2016



INTRODUCTION

This manual contains the information needed to install, operate, and maintain Beck Model Group 29 Electric Actuators, manufactured by Harold Beck & Sons, Inc. of Newtown, Pennsylvania.

The Group 29 linear actuator is a powerful control package designed to provide precise position control of valves and other devices requiring up to 6,100 lb (27 134 N) of thrust.



NOTICE: This manual includes information that will make installation simple, efficient, and trouble free. Please read and understand the appropriate sections in this manual before attempting to install or operate your actuator.

TABLE OF CONTENTS

Product Description	4
General Specifications	6
Outline Dimension Drawings	8
Installation	10
General	10
Wiring	12
Start-up	16
Configuration & Setup	17
Switches	18
Digital Control Module (DCM-3)	20
HART® Interface	21
Configuration & Setup	21
Calibration	26
Communication	29
Alarm Messages	39
Local Interface	42
Configuration & Setup	42
Calibration <i>Demand</i>	45
Calibration <i>Position</i>	47
Calibration <i>Direction Change</i>	48
Serial Interface	49
Configuration & Setup	49
Commands	51
Maintenance	57
Services	59

PRODUCT DESCRIPTION

The Beck Group 29 linear valve actuator is engineered to provide precise, reliable control of all types of modulating globe valves. The Group 29 is available with microprocessor-based electronics to support advanced control features and flexibility. The Group 29 is also available in a model for open/close operation through direct AC control.

Ideally suited for process control applications in even the harshest environments, the Group 29 is easily mounted on most valves and handles valve thrust requirements up to 6,100 lb (27 134 N).

The Beck control motor is specially designed to work with the actuator's on-board control electronics. The motor will not coast or over-shoot, and will not overheat, even under continuous modulation. Beck motors have grease-sealed bearings and require no maintenance.

A ball screw design, along with an advanced actuator control algorithm and Beck motor, ensures repeatable modulation as precise as 0.1% of span.

An easy to turn, spoke-free Handwheel is incorporated into the design of Group 29 actuators to allow manual operation during installation or power outages. The Handwheel can be used to easily operate valves even under full load conditions.

Valves may also be operated at their individual locations with a built-in electric Handswitch.

Beck's Digital Control Module (DCM-3) provides precise actuator control in response to a modulating Demand input signal. It also provides intelligent calibration, easy setup changes, and diagnostic information. A HART® communications interface allows remote access of all features and information. A local interface provides quick pushbutton setup and diagnostics without the need for a handheld or remote device. A serial interface also allows for actuator configuration changes, actuator information reporting and to assist in troubleshooting.

Beck's CPS-4 Contactless Position Sensor provides accurate position measurement in demanding environmental conditions, with no contacting or wiping surfaces to wear or intermittently lose contact.

All Beck electric actuators have individual weatherproof enclosures to protect the main components. Group 29 actuators are also available for use in hazardous locations.

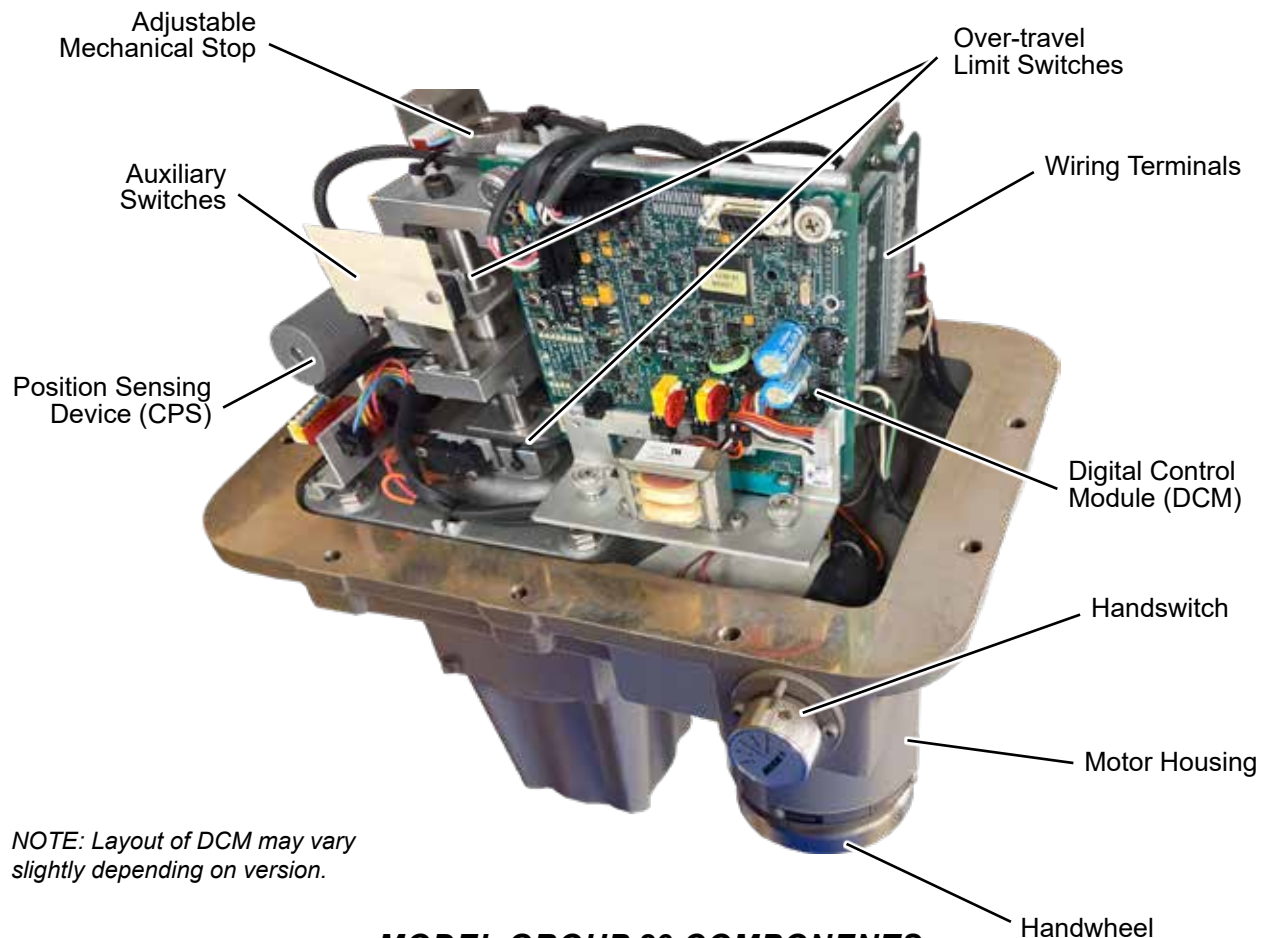

CONTROL & OPERATING FEATURES

In addition to actuator control, the microprocessor-based electronics provide a host of features and functions. Some of the advanced features include:

- Compatible with common asset management systems.
- Two-way digital communications via HART protocol or DB9 serial connection.
- Simplified calibration without any mechanical or electrical adjustment.
- Actuator diagnostics and operating statistics available locally or remotely.
- Easy configuration, setup and documentation of actuator operating parameters.
- Live thrust measurement and protection against excessive thrust.
- Stall protection with configurable stall time setting.
- The choice of linear, square or 20-segment custom input signal characterization.
- All operating parameters including internal temperature can be displayed via HART.
- Configurable action on loss of demand input signal.
- Read/write parameters including tag and descriptor information, last calibration date, and model and serial numbers are saved on board.
- Ability to restore all actuator calibration and setup information to the factory "as-built" configuration.

HAZARDOUS LOCATION ACTUATORS FOR GAS AND DUST AREA CLASSIFICATIONS (OPTIONAL)

Group 29 actuators are available approved for the following Protection Methods and Protection Concepts:

CSA (USA/Canada)

Class I, Division 1 & 2, Groups C & D T4A

Class II, Division 1, Groups E, F & G T4A

Class II, Division 2, Groups F & G T4A

Class III, Division 1 & 2 T4A

*Temperature codes based on an ambient temperature of -40°C to 40°C per NEC 500

Type 4X; IP66/IP68 (3 m/48 hrs.)

CE-ATEX (Europe)

CE  II 3 G Ex nC_c IIB 140°C (T3)

CE  II 3 D Ex tc IIIC T140°C

*T_{amb} = -40°C to 60°C ; IP66/IP68 (3 m/48 hrs.)
per ATEX Directive 94/9/EC

*NOTE: 29-600 actuators equipped with the 20-2201-43 motor have a low temperature rating of -20°C .

GENERAL SPECIFICATIONS

Output Thrust and Timing

Model No.*	Thrust (lbs.) [N]	Stroke Timing** (sec./in.)[sec./cm]	Minimum Stroke Length (in.)[mm]	Maximum Stroke Length (in.)[mm]
29-10_	1000 [4 450]	10 [3.9]	0.50 [13]	2 [51]
29-25_	1700 [7 565]	10 [3.9]	0.50 [13]	2 [51]
29-25_	2100 [9 345]	12.4 [4.9]	0.50 [13]	2 [51]
29-25_	2700 [12 015]	15 [5.9]	0.50 [13]	2 [51]
29-60_	2100 [9 345]	9.4 [3.7]	0.75 [19]	4 [102]
29-60_	2600 [11 570]	11.6 [4.6]	0.75 [19]	4 [102]
29-60_	3200 [14 240]	14 [5.5]	0.75 [19]	4 [102]
29-60_	4100 [18 245]	9.4 [3.7]	0.75 [19]	4 [102]
29-60_	5000 [22 250]	11.6 [4.6]	0.75 [19]	4 [102]
29-60_	6100 [27 145]	14 [5.5]	0.75 [19]	4 [102]

* "X" designates control options 3 or 9.

** Timings based on 60Hz power; 50Hz timing = 1.2 x 60Hz timing.

Actuator Power 120 V ac single-phase, 50 or 60 Hz
240 V ac single-phase, 50 or 60 Hz

Allowable Tolerance +10% / -15%

Max. Current and Power 29-100 -- .65A, 78W @ 120 V ac; .33A, 78W @ 240 V ac
29-250 -- 1.4A, 170W @ 120 V ac; .70A, 170W @ 240 V ac
29-600 -- 3.3A, 400W @ 120 V ac; 1.65A, 400W @ 240 V ac

Operating Conditions -40° to 185°F (-40° to 85°C)
0 to 100% relative humidity, non-condensing
Actuators designed for hazardous locations are available.

Communication Interface* HART protocol, local pushbutton/LEDs and DB9 Serial commands.

Demand Input Signal Range
(DCM-3)* 4-20 mA, 1-5 V dc

Minimum Step* 0.1% typical

Linearity* ±1% of span, max. independent linearity

Hysteresis* 0.25% of span at any point

Demand Input Signal
Characterization* Linear (actuator output shaft moves proportionally to input signal).
Square (actuator output shaft moves proportionally to square of input signal).
Twenty segment custom input signal characterization.

Position Feedback Signal* 4-20 mA or 1-5 V dc

Isolation* Demand input and position Feedback signals are isolated from ground and the ac power line. Signal buffering provides 24 V dc isolation between the Demand and Feedback signals.

Action on Loss of Power	Output shaft stays in last position.
Action on Loss of Input Signal (Power on)*	Stays in place or runs to any preset position (configurable).
Excessive thrust Protection (Optional)*	If the output thrust of the actuator exceeds 150% of the actuator rating, the motor will shut off (configurable from 25% to 150%).
Stall Protection*	If the motor tries to run in one direction for more than 300 seconds (configurable from 30 to 300 seconds), the motor will shut off.
Over-travel Limit Switches	Two Form C (Retract and Extend) provide over-travel protection (rated 6A, 120 V ac).
Auxiliary Switches (Field adjustable)	Two Form C and two Form A, rated for 1 A, 240 V ac.
Customer Wiring	Terminals accommodate up to 12 AWG (3.31 mm ²).
Handswitch	Permits local electrical operation, independent of Demand Input signal.
Handwheel	Provides manual operation without electrical power.
Motor	Does not coast or overshoot and will not overheat, even under continuous modulation.
Gear Train	High efficiency, precision-cut, heat-treated alloy steel and ductile iron spur gears.
Mechanical Stops	One fixed and one adjustable mechanical stop prevent over-travel during automatic or manual operation.
Enclosure	Precision-machined aluminum alloy casting, painted with corrosion-resistant polyurethane paint, provides a rugged, dust-tight, weatherproof enclosure. IP66/IP68 (3 m/48 hrs.); Type 4X ¹ enclosure. Actuators designed for hazardous locations are also available. »Internal water damage is not covered by warranty. ¹ Contact Beck at 215-968-4600 for model specific ratings.
Mounting Orientation	Any orientation—no limitations.
Standards**	CSA Listed; CE Compliant; UKCA Compliant

* Applicable to Option 9 model only.

** NOTE: May not be available with all options and models. For more information, please call Beck at 215-968-4600.

OUTLINE DIMENSION DRAWINGS

MODEL 29-100

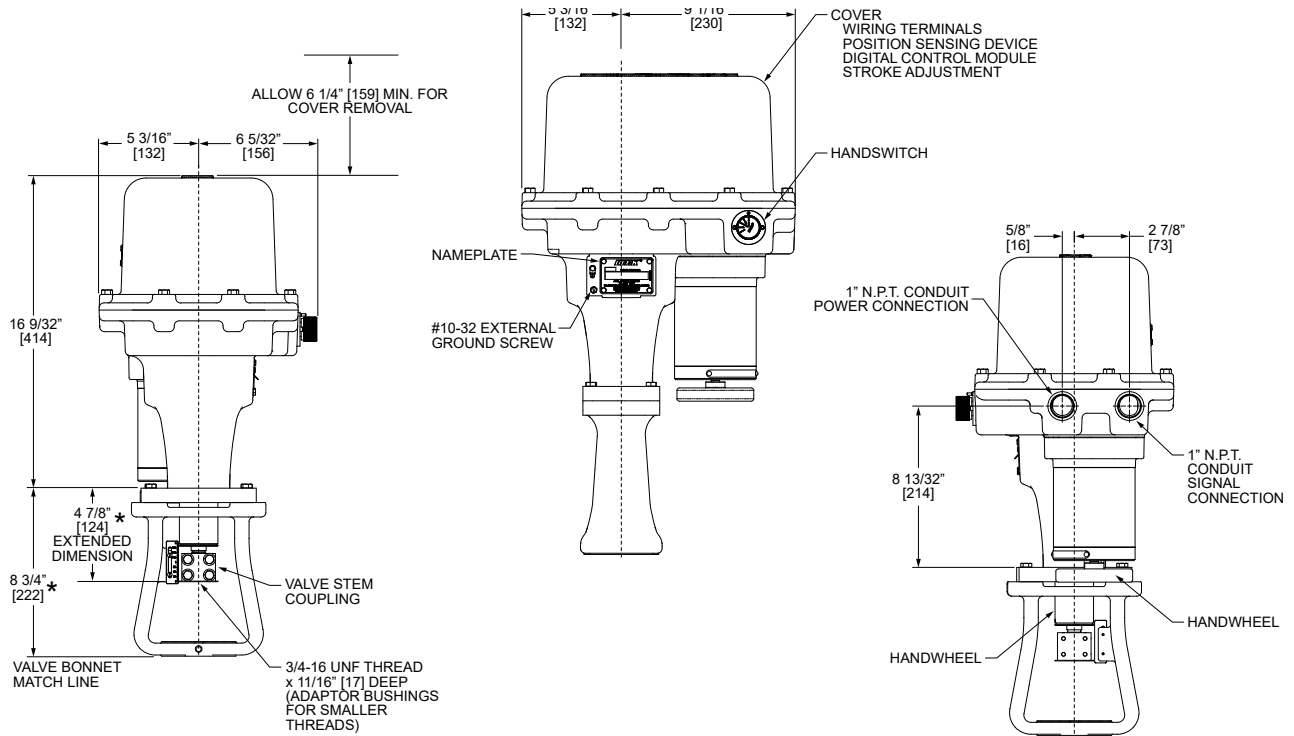

MODEL 29-250

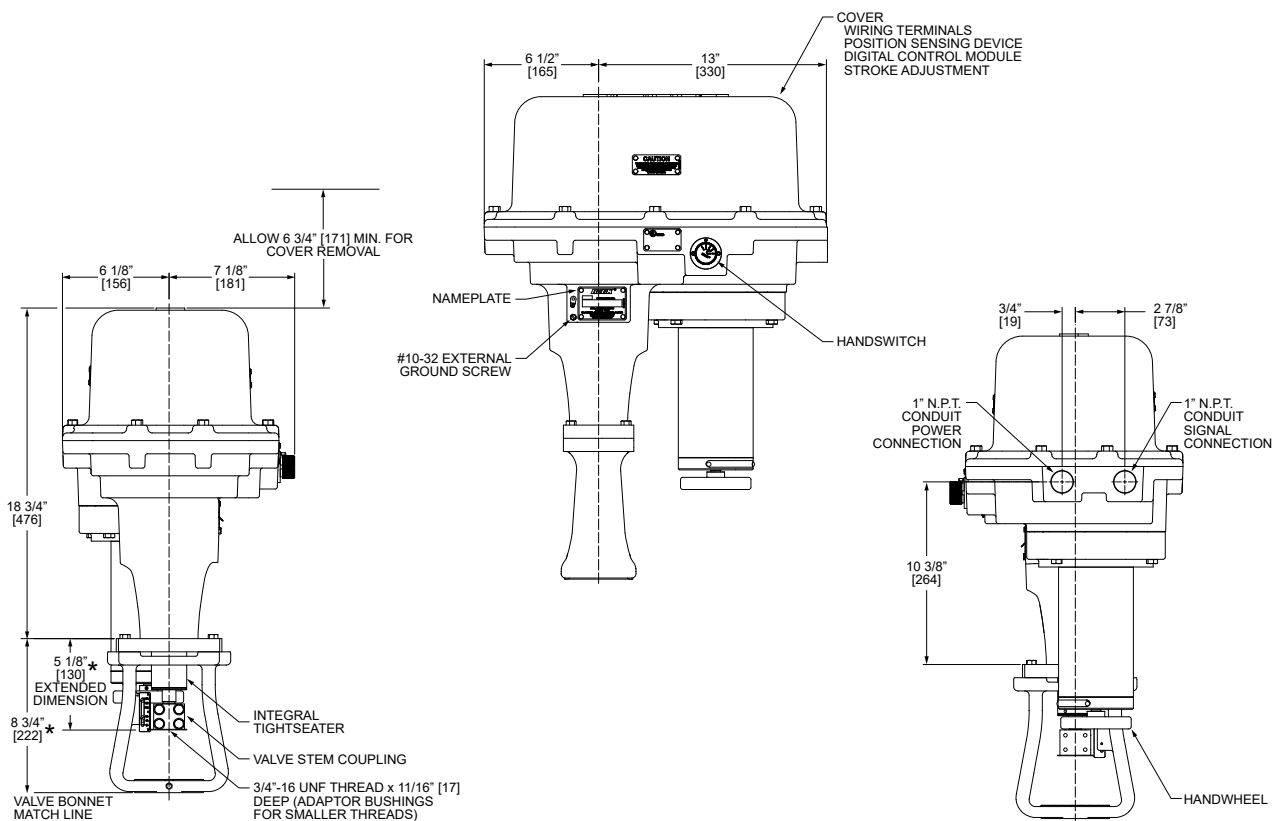

MODEL 29-600

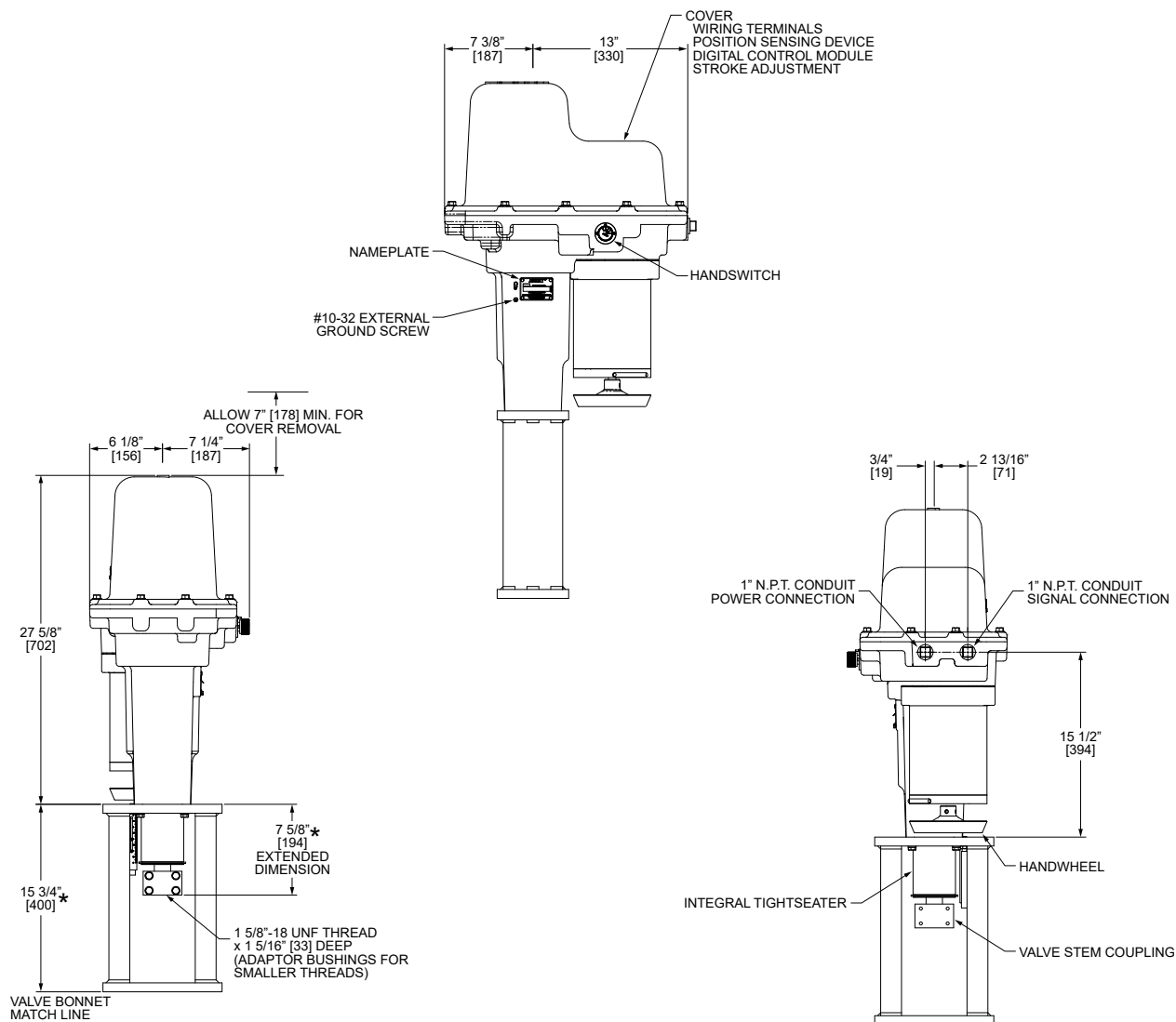

* TYPICAL MOUNTING FEATURE -- MAY VARY PER APPLICATION

ALL DIMENSIONS ARE IN INCHES AND [MM]

ALL DIMENSIONS ARE SUBJECT TO CHANGE

THE ORIENTATION BETWEEN THE ACTUATOR AND MOUNTING YOKE MAY NOT BE ROTATED

ACTUATOR INFORMATION & FASTENER GUIDE

BECK ACTUATOR MODEL NO.	ACTUATOR SHAFT TRAVEL RANGE IN. [MM]	APPROX. WEIGHT LBS. [KGS.]	FASTENER	SIZE (IN.)	TORQUE LB-FT [N·M]
29-100	1/2–2 [13–51]	94 [43]	Cover Screws	5/16-18	14 [19]
			Motor Screws		11 [15]
29-250	1/2–2 [13–51]	152 [69]	Cover Screws	3/8-16	30 [41]
			Motor Screws		15 [20]
29-600	3/4–4 1/2 [19–114]	220 [100]	Cover Screws	3/8-16	30 [41]
			Motor Screws		15 [20]

INSTALLATION General

STORAGE INFORMATION

The actuator should be stored in its shipping carton in a clean, dry area.

If it is necessary to store the actuator outdoors for a long period of time, it should be removed from its shipping carton and stored above ground. A waterproof cover should be securely fastened over the actuator. Do not stack actuators on top of one another. Stored actuators should be periodically checked to make sure no condensation has formed in the control compartments. Damage due to moisture while in storage is not covered by warranty.

UNPACKING

Group 29 actuators are shipped in standardized shipping containers. Actuators mounted on valves may be packed in cardboard containers or strapped to a skid and crated, depending on size. After unpacking, the wooden platform may be used to transport the actuator to the installation site.



WARNING

Installation and service instructions are for use by qualified personnel only. To avoid injury and electric shock, do not perform any servicing other than that contained in this manual. Please read and understand the appropriate sections in this manual before attempting to install or operate your actuator.



CAUTION

Hot surfaces! Surfaces of equipment may be at an elevated temperature depending on operating conditions and environment. Allow to cool before servicing.

INSTALLATION—MECHANICAL

Beck actuators can be furnished with valves mounted as unitized assemblies ready for pipeline installation.



CAUTION

Whenever an actuator is being mounted on a valve, it is good practice to remove the valve from service. Observe the following precautions:

- Know what fluid is in the line
- Wear the proper protective equipment
- Disconnect electrical power
- Depressurize the pipeline
- Refer to the valve maintenance manual for specific instructions

Installing the Actuator on a Valve or Removing the Actuator from a Valve

Consult the *Beck Valve Mounting Specification sheet* that was shipped with the actuator for detailed instructions.

Installing the Valve / Actuator Assembly

The Beck actuator can be mounted in any convenient orientation. There is no preferred operating position. See pages 8 and 9 for dimensions and cover removal clearance requirements.

Inspect the valve and pipe flanges to be sure they are clean. Be certain that other pipelines in the area are free from pipe scale or welding slag that could damage the gasket surfaces.

Carefully lift the assembly and position the valve in pipeline. Install and tighten flange bolts according to the valve and / or gasket manufacturer's instructions.

NOTE: The valve may have undergone temperature variations in shipment. This could result in seepage past the stem seals. Refer to the valve manufacturer's maintenance instructions for packing adjustments.

INSTALLATION—ELECTRICAL

NOTE: All Beck actuators are shipped from the factory ready for installation; no electrical adjustments are required before placing them in operation. Each actuator is set up and calibrated to the customer's specifications that were written into the equipment order.

Two 1" N.P.T. conduit entrances are provided for power and signal wiring to the actuator. Temporary plugs are installed in the conduit entrances at the factory for shipping only and are not intended for permanent use. Prior to actuator operation, all conduit entrances must be properly sealed in accordance with National Standards or Regulatory Authorities.

Wiring should be routed from below the actuator so that condensation and other contaminants flow away from the conduit entrances. Prior to actuator operation, all conduit entrances must be properly sealed in accordance with National Standards or Regulatory Authorities.

Terminal locations and connections for Option 9 actuators are described beginning on page 12 and a typical wiring schematic is provided on page 14 (Option 3 actuators have different terminal connections; see page 15 for typical wiring schematic).

Power and signal wires must be routed to the actuator separately and be either shielded cables or installed in conductive conduit and/or cable trays.

A large, clearly labeled terminal block is located under the actuator cover. Terminals are designed to accommodate one wire. Redundancy of the terminals (i.e., 1A, 2A, 3A, etc.) is provided for additional wiring connections, if necessary. See page 13 for terminal block detail.



CAUTION

Always close the cover immediately after installation or service to prevent moisture or other foreign matter from entering the actuator.

Refer to the wiring diagram furnished with your Beck actuator for proper AC power and signal connections. It is advisable to provide normal short circuit protection on the AC power line. A copy of the wiring diagram is shipped with each actuator and attached to the inside of the cover. If there is no wiring diagram available, you may obtain a copy from Beck by providing the serial number of your actuator.

Your Beck actuator has been supplied for 4–20 mA operation unless otherwise specified as 1–5 V dc operation at the time of order. To convert to 1–5 V dc operation, remove resistor R11 from the DCM-3 board (see illustration below). To convert to 4–20 mA operation, add a 250 ohm resistor to the DCM-3 board in the R11 location (shown below).

For maximum safety, the Beck actuator body should be grounded. Use the power and signal grounding terminals in the wiring compartment of the actuator.



R11
(located between
TP2 & TP3)

DCM-3

NOTE: Layout may vary slightly depending on DCM version.

INSTALLATION Wiring

TERMINAL CONNECTIONS

**Capacity: #12 AWG (3.31 mm²) wire
(see page 13)**

Input Power Terminals 1 and 2

Group 29 actuators are available configured for either 120 or 240 Vac, single-phase (refer to actuator nameplate for specific voltage rating). Input power connects to terminals 1 and 2; ground connects to an enclosure ground screw.

Form C Non-dedicated Switches Terminals 3 through 8

Group 29 actuators include two Form C “auxiliary” switches which are actuated by cams on the control shaft. These switches are useful for indicating actuator shaft position information to the plant control system. Connections to the switches are at terminals 3 through 8. The switch contacts are rated 250 Vac, 1 A.

System Alarm Terminals 9, 10 and 11

The alarm relay is 250 Vac, 1A with Form C contacts (terminal 10 is common). Terminals 10 and 11 should be used if the contacts are to open during alarm conditions and stay closed during normal operation. Terminals 9 and 10 should be used if the contacts are to close during alarm conditions and stay open during normal operation.

Handswitch Auto Indication Terminals 12 and 13

Indication for the position of the Handswitch is available at terminals 12 and 13. The switch contacts are Form A. When the Handswitch is in AUTO, the contacts are closed; and when the Handswitch is not in AUTO, the contacts are open. The contacts are rated 250 Vac, 1 A.

Form A Non-dedicated Switches Terminals 14 through 17

Group 29 actuators include two Form A “auxiliary” switches which are actuated by cams on the control shaft. These switches are useful for indicating actuator shaft position information to the plant control system. Connections to the switches are at terminals 14 through 17. The switch contacts are rated 250 Vac, 1 A.

Demand Signal Terminals 18 and 19

The DCM-3 monitors the signal at terminals 18 (–) and 19 (+), and changes the output shaft position to match the signal at these terminals.

Feedback Signal Terminals 20 and 21

The Feedback module transmits a signal on terminals 20 (–) and 21 (+) that is proportional to the actuator output shaft position.

Control Override Inputs Terminals 22 through 25

The override terminals are provided to override the standard analog demand input signal by means of relay logic input signals.



CAUTION

Do not connect an external voltage source to override terminals 22–25; an external voltage source may damage the DCM-3 circuitry.

Connecting terminal 23 (RET) to terminal 22 (COM) will cause the actuator shaft to retract. Similarly, the actuator shaft will extend when terminal 24 (EXT) is connected to terminal 22 (COM). The actuator will stop regardless of other input signals when terminal 25 (STOP) is connected to terminal 22 (COM).

The connection to terminal 22 is designed to be made through relay contacts or through a solid state switch capable of sinking at least 5 mA dc. When the circuit is open, terminals 23, 24, and 25 are 5 V dc with respect to terminal 22.

TERMINAL CONNECTIONS

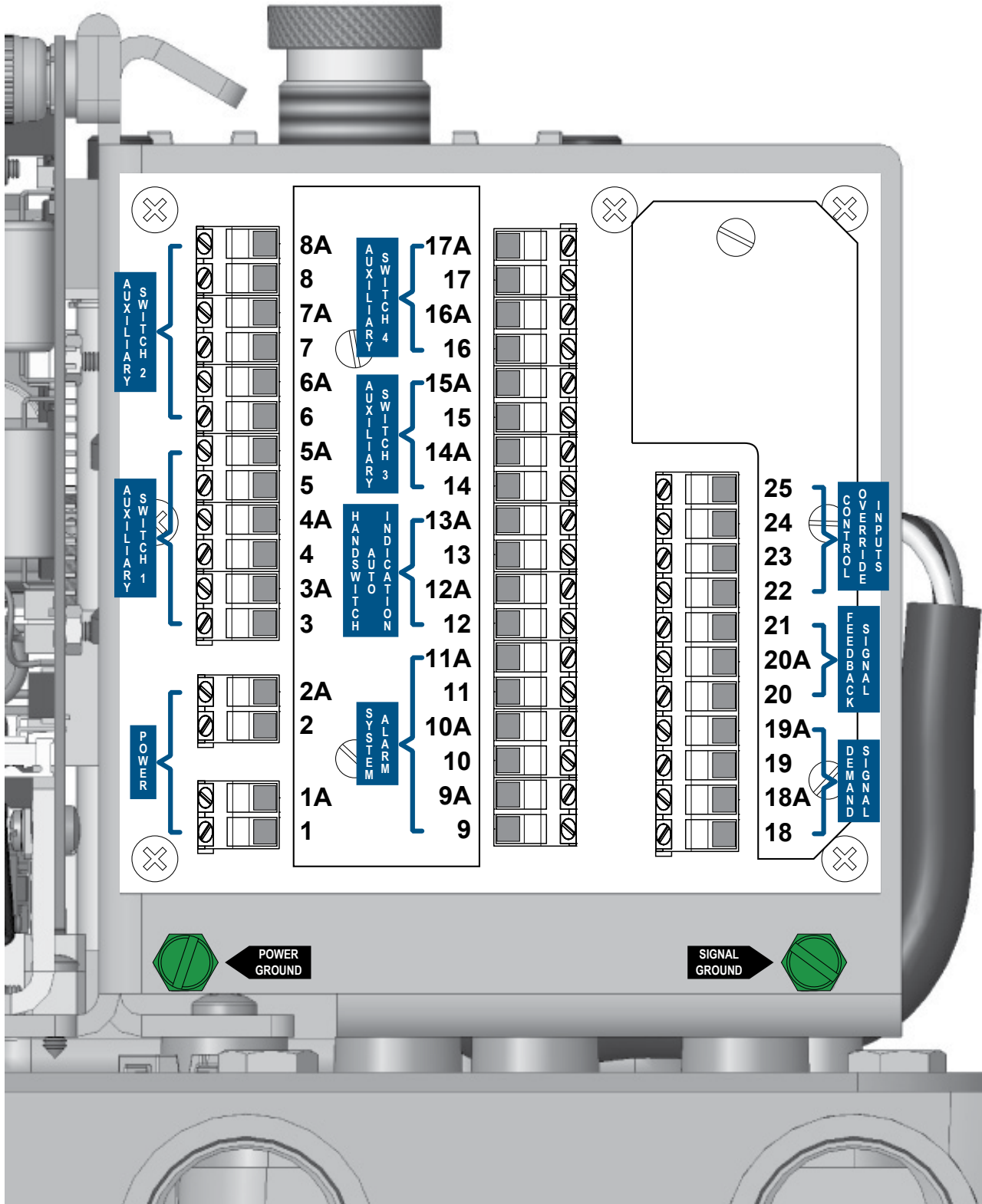

INSTALLATION Wiring

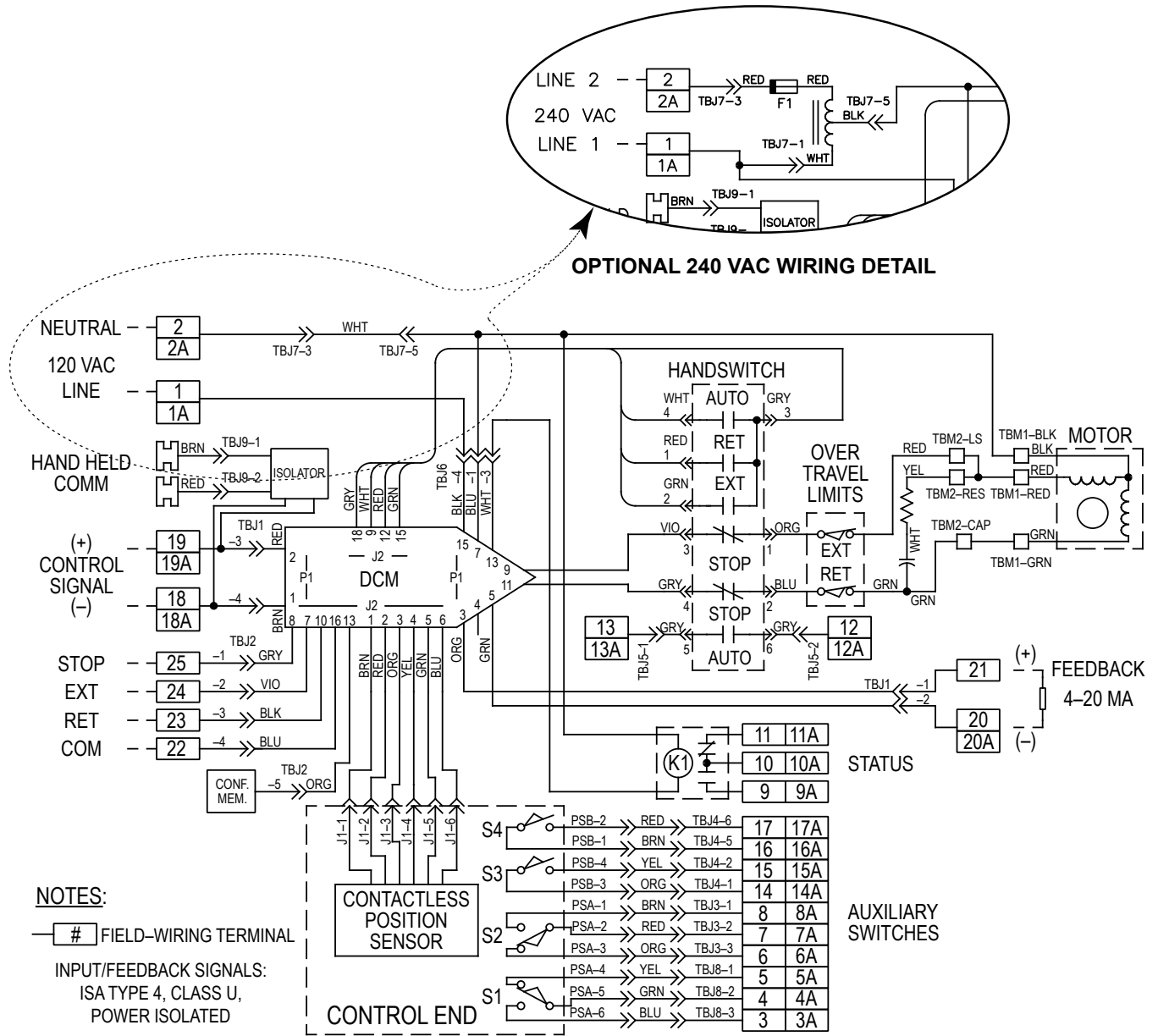

TYPICAL OPTION 9 WIRING SCHEMATIC

NOTE: A wiring schematic specific to each actuator is located under the wiring terminal cover.

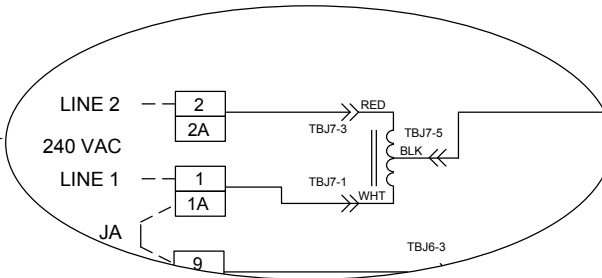

OPTIONAL 240 VAC WIRING DETAIL

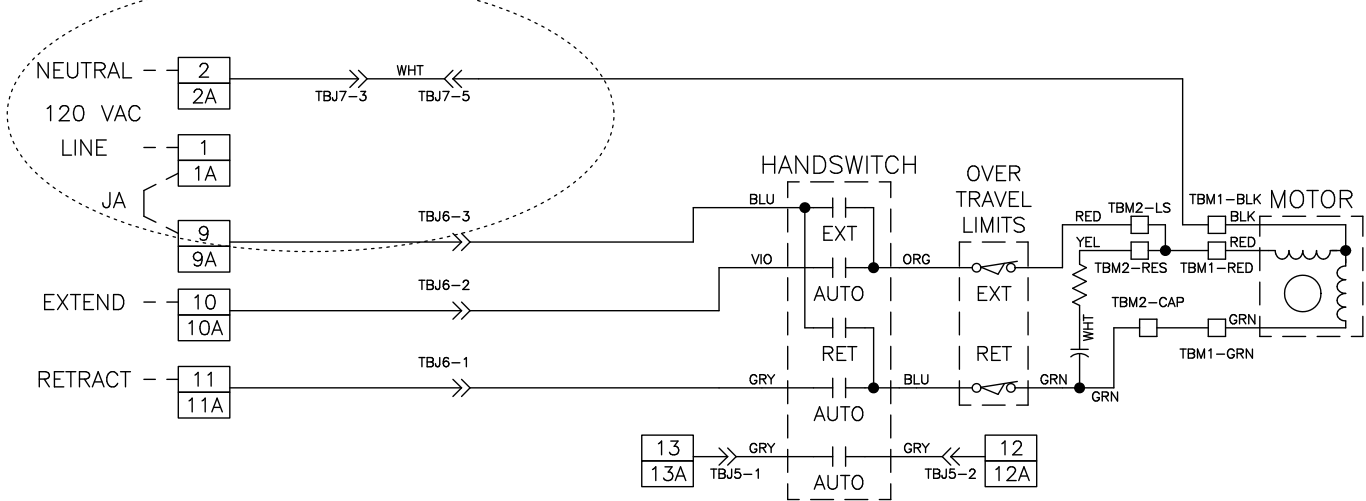

NOTES:

1. # FIELD-WIRING TERMINAL
2. REMOVE JUMPER JA TO PREVENT HANDSWITCH INITIATED MOTION

TERMINAL CONNECTIONS FOR REMOTE CONTROL:	
RET	LINE TO RETRACT
EXT	LINE TO EXTEND
STOP	NONE

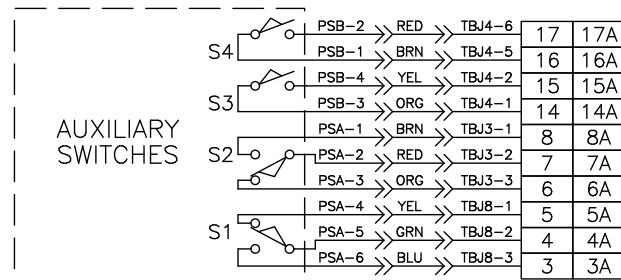

TYPICAL OPTION 3 WIRING SCHEMATIC

NOTE: A wiring schematic specific to each actuator is located under the wiring terminal cover.

INSTALLATION Start-up

BEFORE START-UP

NOTE: All Beck actuators are shipped from the factory ready for installation; no electrical adjustments are required before placing them in operation. Each actuator is set up and calibrated to the customer's specifications that were written into the equipment order. If your requirements have changed since the time of order, the following sections will provide the instruction necessary to reconfigure your actuator.

Confirm that the proper input power voltage is available. Check the **actuator** configuration to make certain the **actuator** matches the power and control system specifications (refer to the **actuator** nameplate). Inspect the **actuator** shaft-to-valve stem connection and **actuator**-to-valve mounting fasteners for correct installation and torque value.

AFTER POWER IS APPLIED

Using the Handswitch (see Outline Dimension Drawings, pages 8–9), run the **actuator** in the RETRACT and EXTEND direction. The **actuator** should run smoothly to each end of travel. If the **actuator** does not run smoothly, switch off power to the **actuator** and recheck the installation wiring.

If the above checks are satisfactory, move the Handswitch to AUTO and control the **actuator** with the Demand signal.



CAUTION

The actuator output shaft will reposition.

Vary the signal and ensure the **actuator** responds appropriately. If applicable, check the feedback signal to see if it is realistic for the **actuator** output shaft position. If the **actuator** does not respond as expected, check for alarm indications on the LEDs of the DCM-3 board or use a HART compatible communicator to check for error messages. **Actuator** status may also be viewed using the DB9 connector (see page 49 for details).

CONFIGURATION & SETUP

All Beck actuators are shipped completely calibrated to customer specifications, and are ready to be installed. If the need arises to change the actuator calibration, confirm that the actuator is installed correctly and operating properly before proceeding with the change. It is also helpful to verify the actuator configuration.

Calibration is performed using the DCM-3 HART interface, the DCM-3 pushbutton local interface, or the DCM-3 serial interface (via the DB9 connector for direct computer communication—see page 49 for details).

If using the HART interface and you are unfamiliar with the HART communicator, please review the Communications section of this manual before continuing.

There are four standard attributes that can be calibrated using the HART interface and communications tool or the serial interface: Position, Demand, Feedback, and Thrust. The local interface allows Position and Demand calibration.

Any actuator calibration changes made using any method can be reversed by using the "Restore to Factory" feature in the HART communicator menu. This feature restores all calibration and setup information to the "as shipped" values. Commands are also available to restore individual parameters.

CONFIGURATION PRIORITY

Group 29 actuators are equipped with one fixed mechanical stop and one adjustable mechanical stop with integral over-travel limit switches. All output shaft travel occurs within these stops, which are outside the electrical range of travel.

The over-travel protection switches are used to limit the electrical control range of the actuator and are factory-set for 101% of travel (unless otherwise specified at time of order). These switches are activated directly by actuator travel and are set 1/64" (.4 mm) before the mechanical stops. The switches are positioned to provide an electrical over-travel protection without opening in the normal operating range.

If there is a need to change the factory calibration and configuration of the actuator, it should be done in a priority sequence as follows:

1. If required, use the adjustment knob to simultaneously adjust the over-travel limit switch and mechanical stop at the RETRACT end of travel.
2. Make any required operating changes such as changing the direction of travel, action upon loss of signal, minimum actuator step size, etc.
3. If required, perform a actuator position calibration.
4. If required, perform a actuator demand calibration.
5. Verify that the actuator operates as desired.

For example, if the actuator is short-stroked (i.e., the full travel from 0–100% is reduced to less than the standard 100% travel—see the Short-stroking instructions in the appropriate DCM-3 section that follows), the adjustable over-travel protection switch (RETRACT) should be reset. Because the over-travel protection switch defines the actuator's maximum range, if it is to be reset, it should be adjusted before performing DCM-3 calibration procedures. Calibration procedures for these switches are the same regardless of the DCM-3 interface (i.e., HART, local or serial) utilized.

The auxiliary switches are cam operated and have no effect on DCM-3 operation; therefore, they can be adjusted at any time without affecting performance or calibration.

CONFIGURATION & SETUP Switches

SWITCH CALIBRATION

NOTE: Your Beck actuator was shipped from the factory ready for installation; no electrical adjustments are required before placing it in operation. Each actuator is set up and calibrated to the customer's specifications that were written into the equipment order.

Under normal operating conditions there is no need to recalibrate the actuator. However, if the application requirements change or are different than specified on the equipment order, the actuator should be recalibrated beginning with the switches, according to the following procedures.

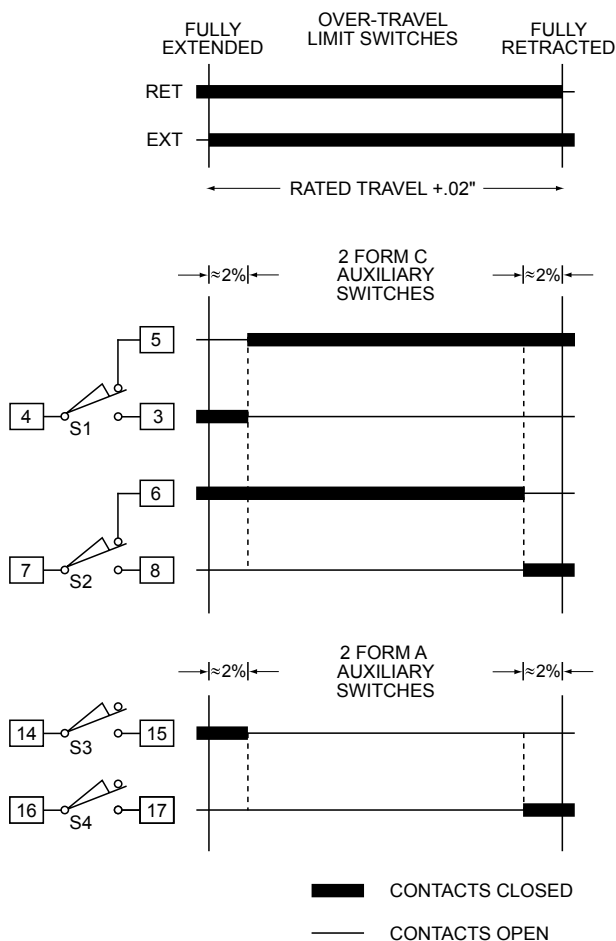

Standard Over-travel Limit and Auxiliary Switch Settings

Over-travel Limit Switch Adjustments

All Group 29 actuators are shipped with two over-travel limit switches. In Option 9 actuators, the switches provide electrical over-travel protection. In Option 3 actuators, the switches establish the actuator travel limits. The switches are set inside the range of the mechanical stops. The switches can be reset to provide over-travel protection (or limit travel) down to a minimum of approximately 45%.

Over-travel switches are triggered by adjustable screws that move with the output shaft. These over-travel limit switches are set at the factory relative to their respective mechanical stop. If a need exists to modify actuator travel, this may be accomplished through adjustment of the RETRACT limit switch by simply rotating the adjustment knob (see illustration below). Because the limit switch is integral to the mechanical stop, rotating the adjustment knob will also adjust the mechanical stop.

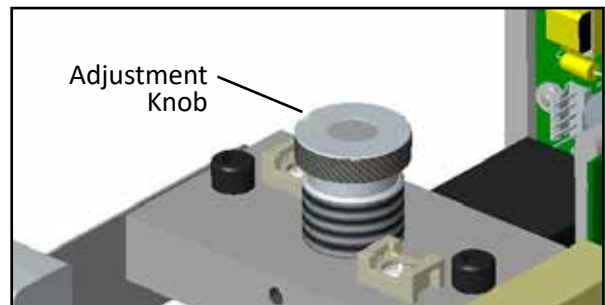

LOCATION OF ADJUSTMENT KNOB

Setting Auxiliary Switches

Standard switch settings for the 4 auxiliary switches are shown on the diagram on page 18. The operating point of auxiliary switches is defined as a percentage of output shaft travel. 100% is defined as the limit of shaft travel in the "RETRACT" direction. The heavy line indicates a closed circuit. Auxiliary switches are operated by cams which are clamped onto the control shaft. Use the following instructions to change the trigger point of auxiliary switches:

NOTE: In the following procedure, it is assumed that switch settings are to be adjusted so that contacts are open when the desired position is achieved.

1. Remove the cover (see outline dimensions beginning on page 8 for identification).
2. Move the output shaft to the desired position (the Handwheel may be used to make fine adjustments to the position of the output shaft).
3. Turn the Handswitch to the STOP position.
4. Disconnect power from the actuator and switch terminals.
5. Connect a continuity meter across the appropriate terminals as depicted in the diagram on page 18.
6. Rotate the appropriate cam using a 3/32" hex wrench (or similarly sized tool) in one of the cam adjustment slots (see drawing on this page for location of slots) until the meter shows continuity (the switch clicks audibly when the switch contact closes).
7. Disconnect the meter and reconnect power.
8. Move the actuator's output shaft in the desired direction so that the cam lobe moves away from the switch lever. If not correct, return to step 2 and reset the cam to the proper orientation.
9. Replace cover and tighten cover bolts to appropriate torque (see fastener guides beginning on page 9).

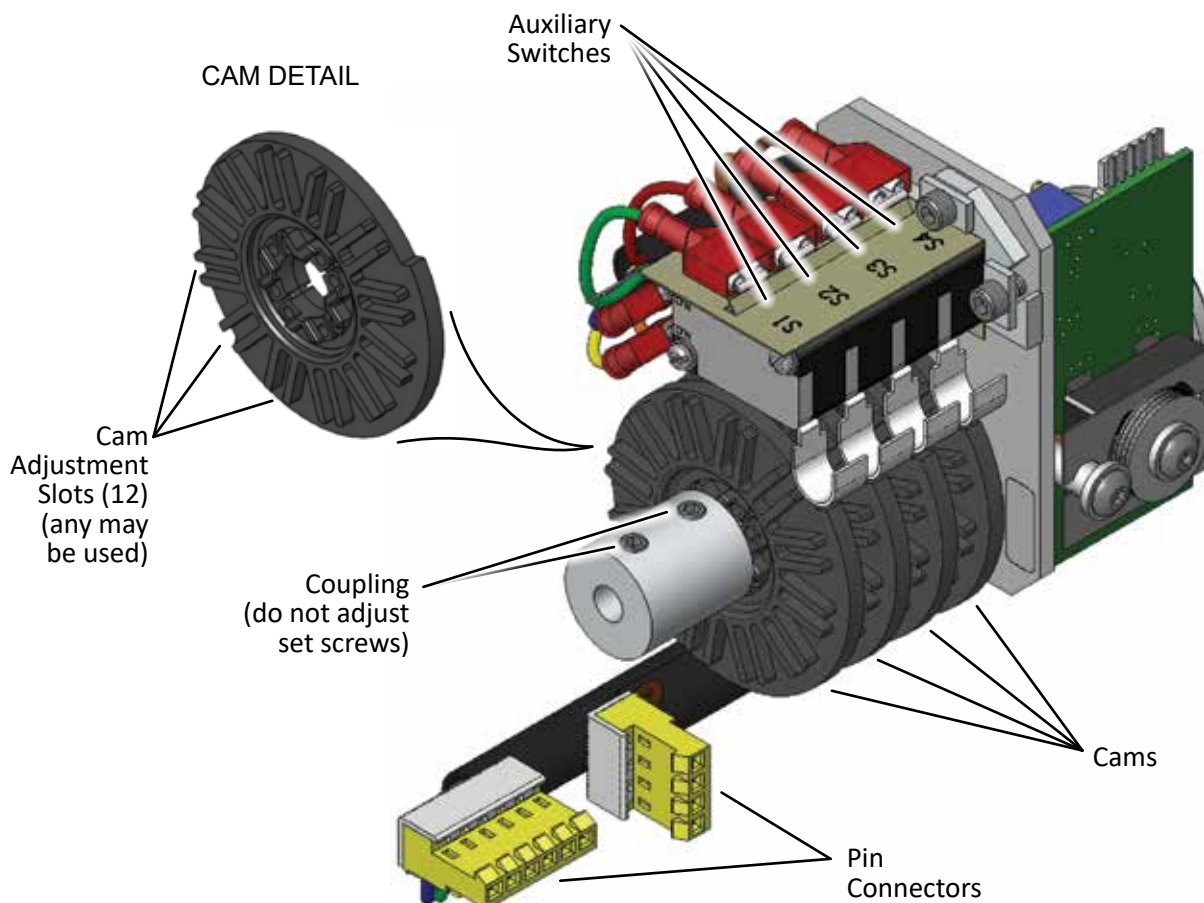

DIGITAL CONTROL MODULE (DCM-3)

All actuators are shipped configured to the customer's specifications and are ready to be installed. If the need arises to change the configuration of the actuator (i.e., change one or more of the setup parameters that define how the actuator operates), this is easily accomplished using one of the three following methods:

1. The HART interface and a communications tool (such as the 475 HART Communicator) as described in the Communications section (see page 29). The following section (beginning on page 21) explains how the actuator is configured using the HART interface and provides instructions for changing each particular setup parameter available. This section is intended to build upon the Communications section, which provides a detailed description of the HART Menu structure and defines all the parameters and commands.

If unfamiliar with the HART communicator and Beck actuators, please review the Communications section (beginning on page 29) before proceeding.

2. The local interface (using the pushbuttons located on the DCM-3). This method does not use HART protocol; therefore, to facilitate configuration modifications, the board has pushbuttons that allow basic configuration and diagnostic functions to be performed local to the actuator. Actuator direction of travel, span of travel and demand signal response can all be easily modified using this interface. Operating parameters less commonly modified can only be changed using the HART (aforementioned) or serial communications (described below).

3. The serial interface (using the DB9 connector on the DCM-3 for direct computer communication—see page 49 for details). The serial interface may be used for actuator configuration changes, actuator information reporting and to assist in troubleshooting.

If the HART interface is typically used, serial communications are simply an alternative to using the HART configuration. If the local interface is typically used, serial communications not only provide an alternate configuration method, but also provide access to parameters that cannot be changed using the local pushbuttons.

A number of configuration setup parameters can be changed to tailor the actuator's operation to the application needs. The following section provides instructions for changing these parameters using the HART interface via a HART Communicator connected to the actuator's HART

communication port (see page 4 for location). Reference the copy of the HART Menu structure (see page 30) when following these instructions. To change these parameters using the Serial Interface, see instructions beginning of page 49.

The DCM-3 default values for both the HART and Serial Interface are listed in the chart below. If not otherwise specified at the time of order, these are the values set in the DCM-3.

NOTE: The instructions on pages 21–41 are applicable to the HART interface only. The instructions on pages 42–48 are applicable to the local interface only.



CAUTION

Throughout the following instructions, some configuration changes will cause the actuator to reposition—this can adversely affect the process and cause potentially dangerous conditions.

DCM-3 HART and SERIAL INTERFACE DEFAULT VALUES

OPERATING PARAMETERS	HART INTERFACE		SERIAL INTERFACE	
	Variable Name	Default Value	Command	Default Value
Actuator Direction (Increasing Signal)	Actuator Dir	RET	drvdir	0 (RET)
Operation Mode	Op Mode	Follow	opmode	0 (Follow)
Thrust Zero	Thrust Null	*	thrust0k	*
Thrust Constant	Thrust Const	*	thrustconst	*
CPS Volts at 0%	CPS Zero	0.900	cpsvatzero	0.900
CPS Volts per 100%	CPS Span	3.000	cpsvspanab	3.000
Percent Travel	Deg Rot	100.00	travel	100.00
Demand LOS Threshold (mA)	DemLimLwr	3.20	demlos	3.20
Demand LOS Mode	LOS Mode	Stay	demlos	sip
Demand LOS Go To Position (%)	LOS Pos	50.00	demlosgtp	50.00
0% Demand (mA)	DemRngLwr	4.00	dem0pctma	4.00
100% Demand (mA)	DemRngUpr	20.00	dem100pctma	20.00
Stall Protection	--	--	Stallprot	1 (enabled)
Stall Time (Sec)	Stall Time	300	stalltime	300
Demand Function	Dem Curve	Linear	demfunc	linear
Step Size	Step Size	0.15	stepsize	0.15
IO Mode	Feedback	Enabled	iomode	1 (fdbk)
0% Feedback (mA)	FB RngLwr	4.00	fdbk0pctma	4.00
100% Feedback (mA)	FB RngUpr	20.00	fdbk100pctma	20.00
Thrust Enable	Thrust Snsr	Enabled	thrustenable	1 (enabled)
Over Thrust Protection	Ovt Prot	Enabled	ovtstop	0 (go)
Shut Down Thrust	ShutDwn Thrust	150	ovtstoplevel	150
Polling Address	Poll Addr	0	polladdr	0
Limit Alarm	LimitSwitch	Accept	limitalarm	0
Actuator Model	Model	29-109	drvmodel	15 (29-109)

*The specific numbers for these values are unique to each actuator and are determined during manufacture. These numbers are noted on a tag affixed under the cover within the control area.

HART INTERFACE Configuration & Setup

NOTE: These instructions are applicable to the DCM-3 HART interface. The instructions on pages 42–48 are applicable to the DCM-3 local interface.

ACTUATOR SHAFT TRAVEL

Actuator shaft travel refers to the direction the output shaft of the actuator moves in response to an increasing Demand input signal. The travel is either retract (RET) or extend (EXT). The control loop operation and physical design of the final control element determine the actuator travel suitable for an application. If the actuator travel needs to be changed, this is easily accomplished by changing the DCM-3 configuration.

Changing Actuator Shaft Travel

STEP 1 - From the HART® communicator “Online” menu, move to the “General Setup” menu and select the “Actuator Dir” parameter. This is accomplished by using the up and down arrow keys to select the appropriate item in each menu and then moving forward by pressing the right arrow key. Follow the Menu Tree (see page 30) to navigate.

STEP 2 - With the “Actuator Dir” parameter selected, press the right arrow key to display the two entry choices: “RET incr” and “EXT incr”. Use the up and down arrow keys to select the desired parameter.

STEP 3 - With desired parameter selected, push the F4 function key, which is defined as the **ENTER** key at the bottom of the display. Pushing this key enters the value and reverts the display back to the “General Setup” main menu.

STEP 4 - At the bottom of the “General Setup” menu, the F2 function key should now be defined as the **SEND** key. Push this key to execute the change.

Reducing Full Travel (Short-stroke Operation)

Typically, it is best to use the full 100% travel of the actuator in response to the 0–100% Demand input signal.

In certain applications, as a last resort, it may become necessary to reduce the full travel of the actuator. In these applications, the DCM-3 can be calibrated to accommodate reduced stroke. The recommended *minimum* full travel is 60%, although it is advisable to make the range as close to 100% as possible for the highest position resolution attainable with the CPS and to avoid possible reduction in thrust.

Reducing the full travel is referred to as “short-stroking” the actuator. This can be easily accomplished by using a HART communication device.

First, navigate to the Configuration menu. Select the General Setup submenu. Select the Travel parameter. Reduce the stroke by entering a percentage of full travel (not less than 60%) of the maximum travel of the actuator.

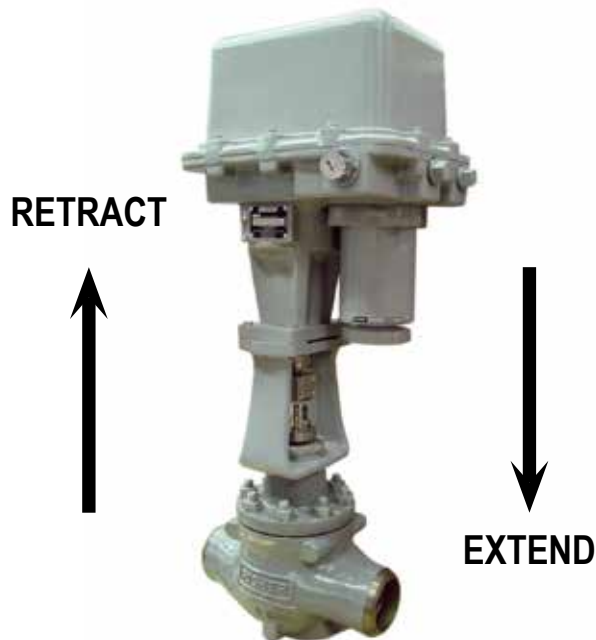

Direction of travel in response to an increasing Demand signal

HART INTERFACE Configuration & Setup

STEP SIZE

The step size is the incremental movement of the actuator shaft in response to signal changes. The step size is factory set at 0.15% unless otherwise specified at the time of order. The step size is adjustable from 0.1% to 2.5%. To adjust the step size, please follow the steps below.

Changing the Step Size

STEP 1 - From the HART® communicator “Online” menu, move to the “General Setup” menu and select the “StepSize” parameter. This is accomplished by using the up and down arrow keys to select the appropriate item in each menu and then moving forward by pressing the right arrow key. Follow the Menu Tree (see page 30) to navigate.

STEP 2 - With the “StepSize” parameter selected, press the right arrow key to display the modifiable entry box, and using the alphanumeric keypad, type in the desired dead band value. Values between 0.1% and 2.5% are valid.

STEP 3 - With the desired value correctly typed into the entry box, push the F4 function key which is defined as the **ENTER** key at the bottom of the display. Pushing this key enters the value and reverts the display back to the “General Setup” main menu.

STEP 4 - At the bottom of the “General Setup” menu, the F2 function key should now be defined as the **SEND** key. Push this key to execute the change.

STALL PROTECTION

The DCM-3 board provides protection of the actuator motor and gearing in the event of a stalled condition. The board accomplishes this by sensing that the actuator is unable to balance for a set period of time known as the “stall time”. If the DCM-3 is unable to balance the actuator for a period greater than the stall time, it shuts off power to the motor and prevents the actuator from continuing to operate against the stall. Resetting the actuator and restoring normal operation is achieved in several ways: Reversing the Demand signal to the actuator, performing a stall reset procedure (see Manual Operation Menu, page 30), performing a board reset procedure (see Diagnostics Menu, page 30), or cycling the actuator ac power.

Changing Stall Time

STEP 1 - From the HART® communicator “Online” menu, move to the “General Setup” menu and select the “Stall Time” parameter. This is accomplished by using the up and down arrow keys to select the appropriate item in each menu and then moving forward by pressing the right arrow key. Follow the Menu Tree (see page 30) to navigate.

STEP 2 - With the “Stall Time” parameter selected, again press the right arrow key to display the modifiable entry box, and using the alphanumeric keypad, type in the desired stall trigger time value. It is normally set to a maximum of 300 seconds, but can be changed to a minimum of 30 seconds.



WARNING

It is possible that the stall time can be set to a value less than the full travel time of some actuators. This could lead to false stall conditions when making very large changes. Typically, this would only occur during start-up, shut down or some other condition that might require a large change in Demand from the controller.

STEP 3 - With the desired value correctly typed into the entry box, push the F4 function key which is defined as the **ENTER** key at the bottom of the display. Pushing this key enters the value and reverts the display back to the “General Setup” main menu.

STEP 4 - At the bottom of the “General Setup” menu, the F2 function key should now be defined as the **SEND** key. Push this key to execute the change.



WARNING

Carefully follow the on-screen warnings and messages when proceeding, because changing actuator setup parameters can cause the actuator to reposition. This can adversely affect the process and cause potentially dangerous conditions.

POSITION FEEDBACK SIGNAL

DCM-3 boards are equipped with a Feedback Sourcing module that provides a 4–20 mA analog output signal that represents the actuator output shaft position in terms of 0–100% of full directional travel. This signal can be remotely monitored or used by a controller or indicator. The user has the option of enabling or disabling the signal. Normally, the signal should be enabled, but in a situation where the feedback is present, but unused (i.e., not wired to a load) a HART® alarm message will be present while communicating using the 475 Communicator. This message is helpful in alerting the user to open feedback wiring, but it is a nuisance when the feedback is purposely disconnected or unused. Disabling the feedback signal turns off the output and eliminates the message; which can also be eliminated by placing a load resistor (e.g., 250Ω) across the feedback terminals 20 & 21.

Enabling / Disabling Position Feedback Signal

STEP 1 - From the HART® communicator “Online” menu, move to the “Setup Checklist” menu and select the “Feedback” parameter. This is accomplished by using the up and down arrow keys to select the appropriate item in each menu and then moving forward by pressing the right arrow key. Follow the Menu Tree (see page 30) to navigate.

STEP 2 - With the “Feedback” parameter selected, press the right arrow key to display the two entry choices: “Enabled” or “Disabled”. Use the up and down arrow keys to select the desired parameter. “Enabled” enables the output signal, while “Disabled” disables the output.

STEP 3 - With desired choice selected, push the F4 function key which is defined as the **ENTER** key at the bottom of the display. Pushing this key enters the selected parameter and reverts the display back to the “Setup Checklist” main menu.

STEP 4 - At the bottom of the “Setup Checklist” menu, the F2 function key should now be defined as the **SEND** key. Push this key to execute the change. This change should not effect actuator positioning but, as with all configuration changes, **carefully follow the on-screen warnings and messages when proceeding.**

DEMAND SIGNAL CHARACTERIZATION

The Beck DCM-3 is designed to receive a 4–20 mA (1–5 V dc) input Demand signal and respond by repositioning the actuator output shaft in proportion to the signal. There are four ways in which the DCM-3 can interpret the Demand signal: Linear, Square Root, Dem Curve Special and Square. The Linear interpretation, which is most commonly employed, simply causes the actuator to position the output shaft in a one-to-one relationship with the Demand. For example, a 1% change in Demand always causes a 1% position response. The Square Root relationship produces a response proportional to the square root of the Demand Signal. The Dem Curve Special relationship allows a customized Demand curve to be setup through a special submenu. The Square relationship produces a non-linear actuator response proportional to the square of the Demand signal. For example, a 25% input Demand is interpreted as 0.25^2 or 0.0625 (6.25%). The square relationship helps to linearize flow response of final control elements that have quick opening characteristics.

Changing Characterization

STEP 1 - From the HART® communicator “Online” menu, move to the “Demand Setup” menu and select the “Dem Curve” parameter. This is accomplished by using the up and down arrow keys to select the appropriate item in each menu and then moving forward by pressing the right arrow key. Follow the Menu Tree (see page 30) to navigate.

STEP 2 - With the “Dem Curve” parameter selected, press the right arrow key to display the four entry choices: “Linear”, “Square Root”, “Dem Curve Special” or “Square”. Use the up and down arrow keys to select the desired parameter.

STEP 3 - With desired choice selected, push the F4 function key which is defined as the **ENTER** key at the bottom of the display. Pushing this key enters the selected parameter and reverts the display back to the “Demand Setup” main menu. If “Dem Curve Special” is selected, proceed to the “Dem Curve Special” sub-menu to setup the desired curve.

STEP 4 - At the bottom of the “Demand Setup” menu, the F2 function key should now be defined as the **SEND** key. Push this key to execute the change.

HART INTERFACE Configuration & Setup

LOSS OF DEMAND INPUT SIGNAL

The DCM-3 board has the capability of determining when the Demand input signal to the actuator is lost, and then responding in the method most appropriate for the application. There are three setup parameters that must be configured in order to define this capability: "LOS Mode", "LOS Pos" and "DemLimLwr". The "LOS Mode" parameter determines how the actuator should respond to the loss of the Demand input signal. It can be configured as "STAY" (which means the actuator holds its current position when the signal is lost) or "GO-TO-POSITION" (which means the actuator moves to a predetermined position). If the "Go-to-Pos" option is selected, the "LOS Pos" parameter is used to determine what output shaft position the actuator must achieve when the input is lost. Finally, a loss of signal is sensed by the DCM-3 when the signal drops below the value set by the "DemLimLwr" parameter. This value is represented in mA of the Demand input signal range. Therefore, the standard 3.2 mA value normally used for this parameter suggests that when the Demand input signal drops 5% below the calibrated 0% value, the DCM-3 senses a lost Demand input and executes the configured loss-of-signal action.

Changing Loss of Signal (LOS) Action

STEP 1 - From the HART® communicator "Online" menu, move to the "Demand Setup" menu and select the "LOS Mode" parameter. This is accomplished by using the up and down arrow keys to select the appropriate item in each menu and then moving forward by pressing the right arrow key. Follow the Menu Tree (see page 30) to navigate.

STEP 2 - With the "LOS Mode" parameter selected, press the right arrow key to display the two entry choices: "Stay" or "Go-to-Pos". Use the up and down arrow keys to select the desired parameter.

STEP 3 - With desired choice selected, push the F4 function key which is defined as the **ENTER** key at the bottom of the display. Pushing this key enters the selected parameter and reverts the display back to the "Demand setup" main menu. If the "Go-to-Pos" choice was selected, go to **STEP 4**, if "Stay" was selected, go to **STEP 6**.

STEP 4 - After entering "Go-to-Pos", select the "LOS Pos" parameter and use the right arrow key to display the modifiable entry block. Unless otherwise specified, this value is set to 50% at the factory. Using the alphanumeric keypad, enter the desired loss of signal position as a percentage of full output shaft travel. Values from -5% to 105% are valid.

STEP 5 - With desired value correctly typed into the entry box, push the F4 function key which is defined as the **ENTER** key at the bottom of the display. Pushing this key enters the value and reverts the display back to the "Demand Setup" main menu.

STEP 6 - At the bottom of the "Demand Setup" menu, the F2 function key should now be defined as the **SEND** key. Push this key to execute the change.



WARNING

Carefully follow the on-screen warnings and messages when proceeding, because changing actuator setup parameters can cause the actuator to reposition. This can adversely affect the process and cause potentially dangerous conditions.

Changing LOS Trip Point

STEP 1 - From the HART® communicator "Online" menu, move to the "Demand Setup" menu and select the "DemLimLwr" parameter. This is accomplished by using the up and down arrow keys to select the appropriate item in each menu and then moving forward by pressing the right arrow key. Follow the Menu Tree (see page 30) to navigate.

STEP 2 - With the "DemLimLwr" parameter selected, press the right arrow key to display the modifiable entry block. Using the alphanumeric keypad, enter the desired Demand signal lower limit value in mA outside of the Demand signal range.

STEP 3 - With desired value correctly typed into the entry box, push the F4 function key which is defined as the **ENTER** key at the bottom of the display. Pushing this key enters the value and reverts the display back to the "Demand Setup" main menu.

STEP 4 - At the bottom of the "Demand Setup" menu, the F2 function key should now be defined as the **SEND** key. Push this key to execute the change.

THRUST OPTIONS

DCM-3 boards have the capability to measure the actuator's thrust output. This, in turn, makes it possible to provide several thrust-related features. The features include a live display of the thrust output on the 475 HART® Communicator display or any other device capable of communicating and displaying HART® transmitted variables. Included is the ability to store peak thrust values within the DCM-3 and view them by accessing the device information menu. To protect the actuator gearing and related equipment, the actuator can be configured to shut off if the thrust exceeds a specified percentage (configurable from 25% to 150%) of the actuator thrust rating. And finally, the DCM-3 will provide a high thrust alarm, via HART® communications, that alerts the user to a high thrust condition when the thrust output exceeds a set value (normally set at 105% of the actuator rating, but may be set as low as 20%).

Enabling Thrust Functions

STEP 1 - From the HART® communicator "Online" menu, move to the "Thrust Setup" menu and select the "Trq/Thrust" parameter. This is accomplished by using the up and down arrow keys to select the appropriate item in each menu and then moving forward by pressing the right arrow key. Follow the Menu Tree (Figure 1, page 30) to navigate.

STEP 2 - With the "Trq/Thrust" parameter selected, press the right arrow key to display the two entry choices: "Enabled" or "Disabled". Use the up and down arrow keys to select the desired parameter. Enabling this parameter will activate the torque measurement features and displays, while disabling the parameter will turn them off.

STEP 3 - With the desired choice selected, push the F4 function key, which is defined as the **ENTER** key at the bottom of the display. Pushing this key enters the selected parameter and reverts the display back to the "Thrust setup" main menu. **Carefully follow the on-screen warnings and messages to return to normal operation.**

Enabling Over-thrust Protection

STEP 1 - From the HART® communicator "Online" menu, move to the "Thrust Setup" menu, make sure that the "Trq/Thrust" parameter is enabled (if not, enable it using the prior procedure) and select the "Ovt Prot" parameter. This is accomplished by using the up and down arrow keys to select the appropriate item in each menu and then moving forward by pressing the right arrow key. Follow the Menu Tree (Figure 1, page 30) to navigate.

STEP 2 - With the "Ovt Prot" parameter selected, press the right arrow key to display the two entry choices: "Enabled" or "Disabled". Use the up and down arrow keys to select the desired parameter. Enabling this parameter will activate the over-torque protection, while disabling the parameter will turn it off.

STEP 3 - With the desired choice selected, push the F4 function key, which is defined as the **ENTER** key at the bottom of the display. Pushing this key enters the selected parameter and reverts the display back to the "Thrust Setup" main menu.

STEP 4 - At the bottom of the "Thrust Setup" menu, the F2 function key should now be defined as the **SEND** key. Push this key to execute the change. This change should not effect actuator positioning but as with all configuration changes, **carefully follow the on-screen warnings and messages when proceeding.**

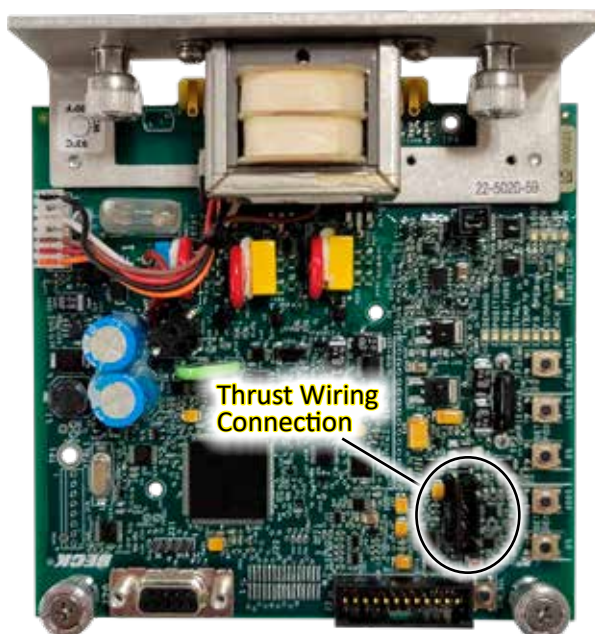

DCM-3 Board showing location of Thrust Wiring Connection

HART INTERFACE Calibration

POSITION

POSITION SENSOR SETUP

In order to correctly position the actuator output shaft in response to the input Demand signal, the DCM-3 board receives a position signal from the actuator's position sensor (CPS) and compares this actual position to the desired Demand input. This process requires that the DCM-3 interprets the CPS signal appropriately for the full range of desired travel. The "PositionSensrSetup" submenu is used to set the DCM-3 to accept the CPS position signal and interpret the appropriate 0–100% range.

All Beck actuators are shipped completely set and calibrated to the customer specifications and are ready for installation. Normally, no adjustments are necessary.

If, however, the position calibration needs to be changed, the "PositionSensrSetup" submenu must be used. The "PositionSensrSetup" is accessible through the "Configuration" menu.

The "PositionSensrSetup" submenu will allow resetting of the minimum travel position of the actuator (Set Pos 0%) and the CPS voltage at the minimum travel position (CPS Zero%). Online help is available through the communication device.

DEMAND

SIGNAL CALIBRATION

DCM-3 boards are designed to accept a 4–20 mA (or 1–5 V dc) analog Demand signal. Narrower spans within this range can also be accommodated for split range operation (see explanation following). The input comes calibrated from the factory for the full range unless otherwise specified. It is not necessary to calibrate the Demand input when the actuator is installed.

If the Demand must be changed, it is accomplished using a HART communication device.

First, navigate to the Configuration menu. Select the Demand Setup submenu. Through this submenu, the Demand range limits and curve specifications may be changed. Online help is available through the communication device.

Split Range Operation

It is sometimes desirable or necessary to have more than one final control element controlling a single process. Often, this type of control strategy requires that two to four Beck actuators each respond to different portions of one 4–20 mA Demand signal from the control system.

This type of operation is called split range operation. For example, consider the most common split range scenario—two actuators split ranged for 50% of the 4–20 mA Demand

signal input. Both actuators are wired in parallel to receive the same 4–20 mA signal (note that the total loop resistance should be 250 Ohms as specified by the HART® communications protocol. The 250 Ohm R11 resistor (see illustration below) must be removed from one of the two actuator DCM-3 boards to allow HART® communications. If more than two actuators are split ranged, the R11 resistor must be removed from all the DCM-3 boards but one), but each actuator's interpretation of the signal must be different. One actuator must interpret 4–12 mA as 0–100% Demand, and one actuator must interpret 12–20 mA as 0–100% Demand. This requires that the actuators have different Demand signal calibrations.

Split-ranging is easily accomplished by determining the break points (12 mA in the example above) and using a HART communication device.

First, navigate to the Configuration menu. Next, select the Demand Setup submenu. Change appropriate Demand range limit accordingly. In the example, one actuator's upper Demand range (DemRngUpr) would be changed from 20.00 mA to 12.00 mA; and the other actuator's lower Demand range (DemRngLwr) would be changed from 4.00 mA to 12.00 mA.

NOTE: Ensure that the L.O.S. (Loss of Demand input signal) settings of the actuators are appropriate for the new configuration. This would involve changing the appropriate Demand LOS limits (DemLimLwr or DemLimUpr). Typically, these settings are -5% and 105% of the Demand range.

DCM-3 Board showing Resistor R11 and Test Points TP1 & TP4

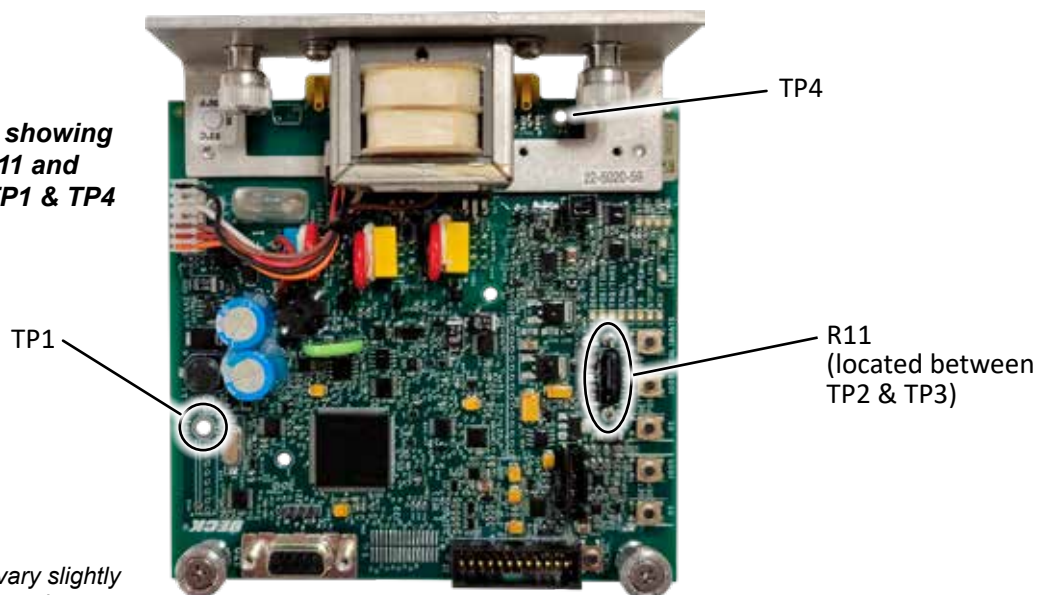

NOTE: Layout may vary slightly depending on DCM version.

HART INTERFACE Calibration

THRUST

THRUST MEASUREMENT

DCM-3 boards have the capability of measuring the actuator output thrust and providing several thrust-related features. The thrust measurement is calibrated to the actuator's rated output at the factory. There is normally no reason to recalibrate this feature in the field, unless a new DCM-3 board has been installed.

In the event that calibration is required, it is easily accomplished by using a HART communication device.

First, navigate to the Configuration menu. Next, select the Thrust Setup submenu. Select the Thrust Zero parameter, which will allow the 0% thrust value to be edited. Enter the number corresponding to the 0% thrust value that is shown on the inside of the DCM-3 cover. Next, select the Thrust Const parameter, and enter the number corresponding to the 100% thrust value that is shown on the inside of the DCM-3 cover. Online help is available through the communication device.

HART INTERFACE Communication

475 HANDHELD COMMUNICATOR WIRING CONNECTIONS

CONTROL ROOM

CONTROLLER DEMAND OUTPUT TO DRIVE TERMINATION

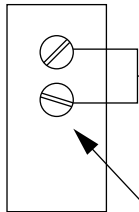

FIELD

FIELD JUNCTION BOX OR MARSHALLING CABINET

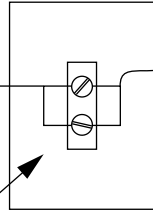

ACCEPTABLE COMMUNICATOR CONNECTION POINTS

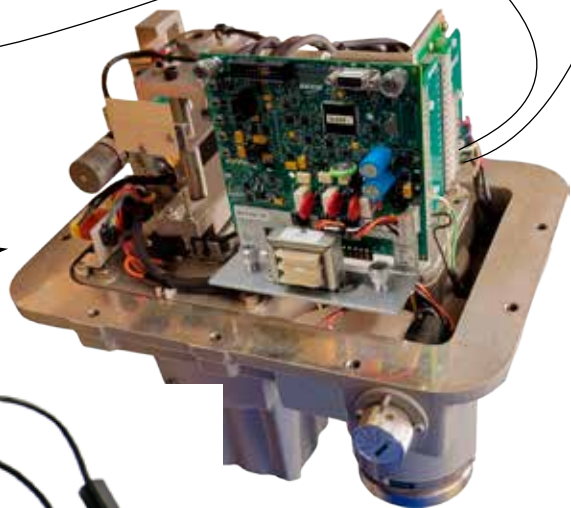
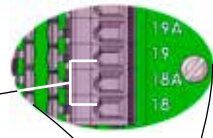

DEMAND SIGNAL TO DRIVE WIRING (TERMINAL 18 & 19)

POLARITY NOT IMPORTANT



HART INTERFACE Communication

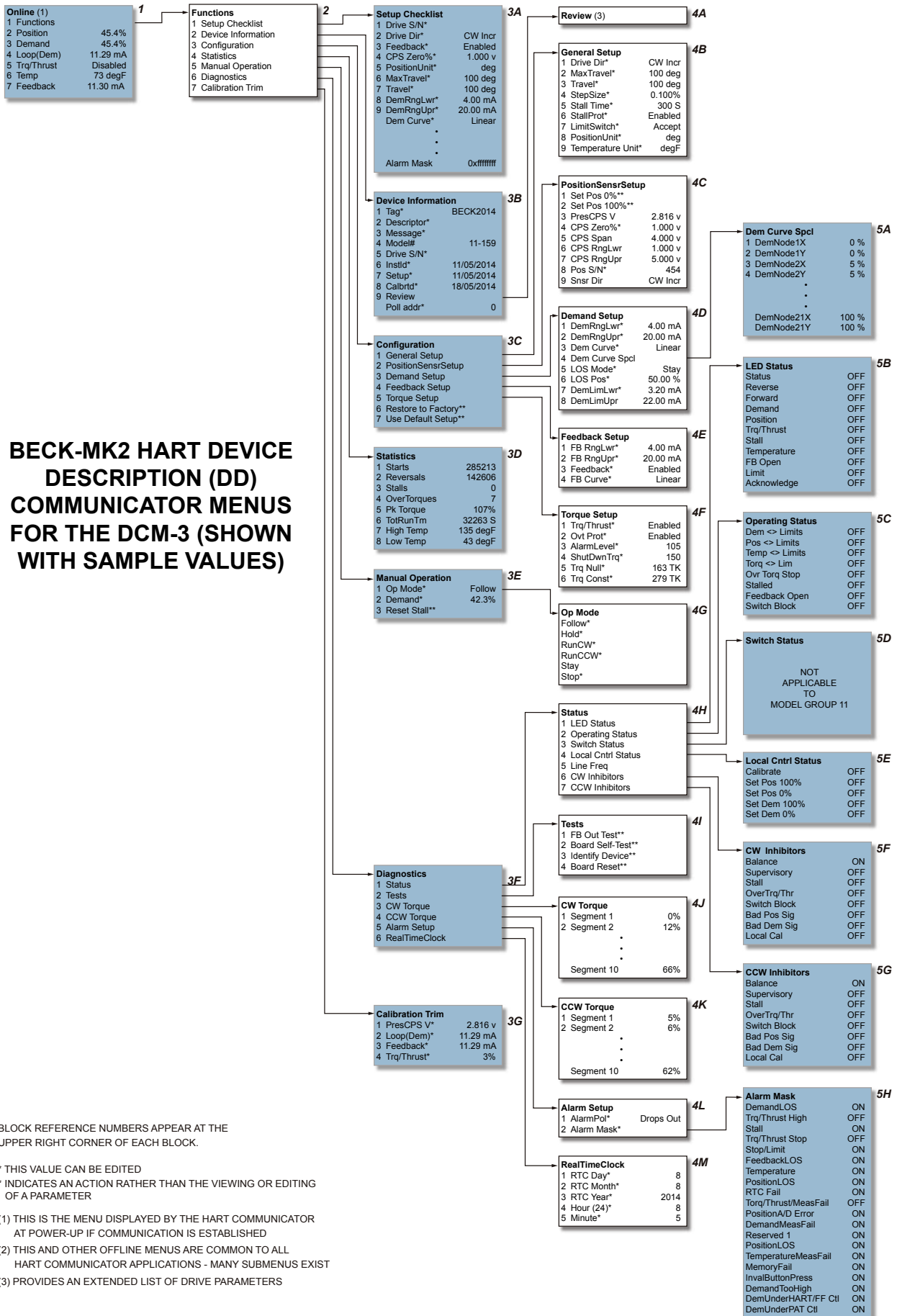

BECK-MK2 HART DEVICE DESCRIPTION (DD) COMMUNICATOR MENUS FOR THE DCM-3 (SHOWN WITH SAMPLE VALUES)

BLOCK REFERENCE NUMBERS APPEAR AT THE UPPER RIGHT CORNER OF EACH BLOCK.

* THIS VALUE CAN BE EDITED

** INDICATES AN ACTION RATHER THAN THE VIEWING OR EDITING OF A PARAMETER

- (1) THIS IS THE MENU DISPLAYED BY THE HART COMMUNICATOR AT POWER-UP IF COMMUNICATION IS ESTABLISHED
- (2) THIS AND OTHER OFFLINE MENUS ARE COMMON TO ALL HART COMMUNICATOR APPLICATIONS - MANY SUBMENUS EXIST
- (3) PROVIDES AN EXTENDED LIST OF DRIVE PARAMETERS

The DCM-3 board is the control center of the actuator. Actuator configuration and calibration are accessed and set through the DCM-3 board. Using the HART® interface requires a HART® compatible communicator. Typically, a universal model 475 HART® communicator is used, but any device, computer or controller capable of communicating with HART® devices and supporting the Beck DCM-3 device description can be used.

HART® INTERFACE

The figure on page 30 displays the interface menu tree for communicating with a DCM-3 using the BECK-MK2 Device Description. This menu tree summarizes possible setup options, features and available information.

HART® COMMUNICATORS FOR BECK-MK2

The BECK-MK2 Device Description requires a HART® Communicator that is fully HART 5 capable and has the ability to import Device Description Language Files (DDL) that are certified by the HART® Communications Foundation.

USING THE HART® COMMUNICATOR

The HART® Communicator leads should be connected in parallel with the analog Demand signal wiring (see figure on page 29). This allows the communicator to simultaneously communicate over the analog input wires. This does not disturb the analog command signal, or disrupt the DCM-3 functions. However, any program changes to the DCM-3 will momentarily suspend the operation of the board (maintains last state) while the change is implemented. Typically, this is only for a second or two.

With the communicator connected in parallel anywhere across the analog Demand wires, it is ready to communicate. Turn on the communicator and wait for communications to be established. Once communicating, the “Online” display (figure, page 30, menu block #1) will appear in the communicator window. If the actuator is multidropped with other devices on a single HART® network, the first display screen will list all devices and require a selection before the “Online” display is shown. The “Online” display provides online information about the present actuator operating conditions. Entering any of the menus shown in the figure on page 30 is accomplished by following the display and using the communicator’s arrow keys. **If the communicator is unable to communicate with the DCM-3, it will display the message, “No Device Found”. If this occurs, check to make sure the leads are securely connected to the Demand wiring and retry. If communications still do not occur, the communicator polling setup may be improperly set. Check the “utility” menu and make sure communications polling is set to “always poll”.**

A communicator keypad and display is shown on page 29. There are four sections: 1) the liquid crystal message display, 2) four function keys beneath the LCD display, 3) six navigational keys in the center section, 4) alphanumeric entry keys at the bottom. For a complete description of the communicator, please see the HART® Communicator manual that is shipped with the communicator.

The alphanumeric keys are used to type in entries. Whenever a selected menu or method requires a value or description to be entered, this key pad is used. Since each key represents four different characters, three shift keys are provided at the bottom of the pad. A particular alphanumeric character is selected by pushing the shift key then pushing the alphanumeric key.

HART INTERFACE Communication

MENU DESCRIPTIONS

(See figure on page 30)

Online Menu

(Block 1)

When communications are established with the communicator, the Online menu is displayed. This is the gateway to all the other menus and it also provides current information about the actuator. Numbered items 2 through 7 provide live, dynamic values of the actuator's output position in percent, the Demand signal to the actuator in percent, the Demand signal in milliamps, the present thrust output, the actuator temperature, and the external position feedback signal in milliamps. Select the first menu item, "Functions", to gain access to the Functions menu. Backing out of the Online menu (using the left arrow key) results in selection of the Offline menu.

Functions Menu

(Block 2)

From the Functions menu, any of the DCM-3 functional menus can be selected and accessed. There are seven functional areas: Setup Checklist, Device Information, Configuration, Statistics, Manual Operation, Diagnostics, and Calibration Trim.

The Setup Checklist (Block 3A) is a menu that allows the user to setup the most important items necessary for basic actuator operation. After completing the setup checklist, further setup can be accomplished using the configuration menu.

The other six functional areas and menus are described in more detail as follows.

Device Information Menu

(Block 3B)

The Device Information menu is strictly an informational page. By entering this menu, a selection of useful information can be viewed and/or edited. There are a total of ten information entries:

1. **Tag** - This 8 character entry can be used as a unique label that correlates to a field device label.
2. **Descriptor** - This entry is a 16 digit field that can be used to provide any description desired.
3. **Message** - This entry is a 32 digit field that can be used to provide any message desired.

4. **Model** - This entry displays the model number of the actuator in which the DCM-3 board is installed. It normally is set at the factory if the board is installed in a actuator. The user can edit the field if desired.
5. **Actuator S/N** - This entry displays the serial number of the actuator in which the DCM-3 board is installed. It normally is set at the factory if the board is shipped in a actuator. If the DCM-3 is shipped as a spare or replacement part, the "Actuator S/N" field will be blank. The user can edit the field if desired.
6. **Installed** - This is a date entry that is normally used to indicate the date that the actuator or DCM-3 board was installed. The date format is mm/dd/yyyy and it can be edited.
7. **Setup** - This is a date entry that is normally used to indicate the date that the DCM-3/ actuator setup was performed. Although this entry is viewed and can be edited in the "Device Information" menu, the user is prompted at the end of performing a "Setup" to enter a date. Entering the date at the prompt automatically updates the date displayed. The date format is mm/dd/yyyy, and it can be edited.
8. **Calibrated** - This is a date entry that is normally used to indicate the date that the DCM-3/actuator was last calibrated. Although this entry is viewed and can be edited in the "Device Information" menu, the user is prompted at the end of performing any "Calibration" method to enter a date. Entering the date at the prompt, automatically updates the date displayed here. The date format is mm/dd/yyyy, and it can be fully edited.
9. **Review** - Scrolls through all device information items, as well as all the other DCM-3 settings, without accessing each item individually. This is an excellent tool for quickly determining how a particular actuator is setup. To edit individual entries, the user must exit "Review" and proceed to the appropriate menu and item.
10. **Poll Address** - This entry can be edited; however, it is normally set to 0. A polling address from 1 to 15 can be entered if the actuator resides on a common HART® network with other HART® devices.

Configuration Menu (Block 3C)

The Configuration menu serves as the gateway to all of the actuator operating setup parameters. The user can select any of five different setup submenus that can be used to configure the actuator based on the physical layout and the desired operation. The five setup submenus are described below. In addition to these five setup menus, there is a "Restore to Factory" selection which resets the actuator configuration to its as-shipped settings. There is also a "User Default Setup" setting which resets the actuator configuration to the settings typical of the applicable actuator model type.

General Setup Submenu (Block 4B)

This menu sets actuator operating parameters. The nine parameter entries are as follows:

1. **Actuator dir** - Defines the rotation of the actuator output shaft, given an increasing Demand signal, looking into the output shaft. Options available are RET Incr (retract on increasing signal) or EXT Incr (extend).
When the actuator direction parameter is changed, the DCM-3 automatically reverses the analog position feedback signal such that it is 4 mA at the 0% input signal position and 20 mA at the 100% position. No recalibration of the CPS is required. This parameter is normally set to retract on an increasing Demand signal unless the user specified extend prior to shipment of the actuator.
2. **MaxTravel** - The maximum available travel distance of the output shaft in inches. This value is entered manually, and must correspond to the actuator design.
3. **Travel** - The number of inches of output shaft travel for 100% span. Edit this value to use a span shorter than the allowable "MaxTravel".
4. **StepSize** - The typical change in Demand signal that can occur before the output shaft will reposition (expressed in percent of span).
5. **Stall time** - The DCM-3 provides stall protection to the entire actuator by shutting off power to the motor and providing a HART® alarm. This entry configures the stall time required to trigger the stall protection. At the factory, stall time is normally set to 300 seconds, but can be edited and set for any value between 30 and 300 seconds. This value should be longer than the timing for full actuator travel.

6. **StallProt** - This entry is set as either "Enabled" or "Disabled". It is used to remove motor power if "Stall time" is reached.
7. **LimitSwitch** - This entry is set as either "Accept" or "Alert" and is used to define whether contacting a limit switch outside of the normal travel range (0% to 100%) will cause an error condition.
8. **PositionUnit** - Sets the numeric unit of measure for the output shaft position in inches ("in").
9. **Temperature Unit** - The unit of measure for temperature. May be set for Fahrenheit ("degF") or Celsius ("degC").

PositionSensrSetup Submenu (Block 4C)

This menu is where all position sensor and external position feedback signal setup is performed. The eight parameter entries are as follows:

1. **Set Pos 0%** - Selecting this parameter sets the present position of the actuator to the minimum travel position. Equivalent to pushing the SET POS 100% pushbutton.
2. **Set Pos 100%** - Selecting this item sets the present position of the actuator to the maximum travel position. Equivalent to pushing the SET POS 100% pushbutton.
3. **PresCPS V** - Displays the present value of the internal Position Sensor voltage, which may also be measured at TP4(+) and TP1(-) on the DCM-3 board. May be edited in the Calibration Trim menu for trimming the Position Sensor A/D converter.
4. **CPS Zero%** - Displays the CPS voltage at the zero percent output shaft position. May be edited to define the CPS voltage at the lowest operating point of travel.
5. **CPS Span** - Displays the CPS voltage span for the maximum allowable output shaft travel.
6. **CPS RngLwr** - Displays the CPS voltage at the lowest available point of travel. Normally set by the factory.
7. **CPS RngUpr** - Displays the CPS voltage at the highest available point of travel. Normally set by the factory.
8. **Pos S/N** - A number which uniquely identifies the position sensor. May be edited.
9. **Snsr Dir** - Displays which direction of output shaft movement will yield an increasing internal Position Sensor signal. Normally set at factory to "RET Incr" (signal increases as the output shaft retracts).

HART INTERFACE Communication

Demand Setup Submenu (Block 4D)

This menu is where all the Demand input signal related actuator parameters are set. The eight parameter entries are as follows:

1. **DemRngLwr** - The value of the Demand signal (in mA) that corresponds to 0%. Normally set to "4.00 mA", this value should be set above the "DemLimLwr" value.
2. **DemRngUpr** - The value of the Demand signal (in mA) that corresponds to 100%. Normally set to "20.00 mA", this value should be set below the "DemLimUpr" value.
3. **Dem Curve** - Allows a choice in the relationship between the applied Demand signal and the desired position of the output shaft. Choices are: Linear, Square Root, Dem Curve Special, & Square.
4. **Dem Curve Spcl** - When "Dem Curve" above is set to "Special", this command allows access to a submenu to setup the preferred Demand curve.
5. **Los Mode** - Sets the output shaft response to a loss of Demand signal condition. Can be set to "Stay" or "Go-to-Pos".
6. **Los Pos** - If "Los Mode" has been set to "Go-to-Pos", this parameter allows the user to define the position (in percentage of travel) to where the output shaft will move during Loss of Signal conditions. May be set between -5.00% and 105.00%.
7. **DemLimLwr** - Sets the minimum usable value of Demand. Below this value, the Loss of Signal condition will be set. Values between 0 mA and 12 mA may be selected. This value should be set lower than the low Demand Range ("DemRngLwr").
8. **DemLimUpr** - Sets the maximum usable value of Demand. This value should be set higher than the upper Demand Range ("DemRngUpr").

Feedback Setup Submenu (Block 4E)

This menu is where all the Feedback signal related actuator parameters are set. The four parameter entries are as follows:

1. **FBRngLwr** - The value of the Feedback signal (in mA) that corresponds to a 0% output shaft position. This value can range between 3.0 mA and 16.0 mA.
2. **FBRngUpr** - The value of the Feedback signal (in mA) that corresponds to a 100% output shaft position. This value can range between 7.0 mA and 21.0 mA.
3. **Feedback** - Enables or Disables the Feedback signal.
4. **FB Curve** - Allows a choice in the relationship between the applied Feedback signal and the actual position of the actuator. Choices are: Linear & Inverted Demand ("InvDem").

Thrust Setup Submenu (Block 4F)

This menu is where all the Thrust related actuator parameters are set. The five parameter entries are as follows:

1. **Trq/Thrust** - Enables or Disables thrust related functions.
2. **Ovt Prot** - Enables or Disables over-thrust protection, which will remove power from the motor if excessive thrust is detected.
3. **ShutDwnThrust** - Sets the value that, if exceeded, will cause the power to be removed from the motor (if "Ovt Prot" is enabled; see above). This will cause a shutdown alarm.
4. **Thrust Zero** - Sets the thrust value that corresponds to 0% thrust applied. This number is represented in "TK" units, and is noted on the label inside the DCM-3 cover (also referred to as "Thrust Zero").
5. **Thrust Const** - Sets the thrust value that corresponds to 100% thrust applied. This number is represented in "TK" units, and is noted on the label inside the DCM-3 cover.

Statistics Menu (Block 3D)

This menu is where all the actuator's stored operating statistics are available. There are eight different statistics available:

1. **Starts** - Logs and displays the total number of starts the actuator motor has made.
2. **Reversals** - Logs and displays the total number of times the motor started in a direction opposite to the previous start.
3. **Stalls** - Logs and displays the total number of stalled conditions the actuator has experienced. For the actuator to register a stall, the DCM-3 board must be unable to balance the actuator position against the Demand input signal for a period exceeding the **Stall Time** set in the General Setup menu.
4. **OverThrusts** - Logs and displays the total number of times that excessive thrust was detected at the output shaft.
5. **Pk Thrust** - Logs and displays the maximum thrust sensed at the output shaft.
6. **TotRunTm** - Logs and displays the total run time of the actuator motor in seconds.
7. **High temp** - Logs and displays the highest temperature in degrees Fahrenheit measured by a temperature sensor resident on the DCM-3 board.
8. **Low temp** - Logs and displays the lowest temperature in degrees Fahrenheit measured by a temperature sensor resident on the DCM-3 board.

Manual Operation Menu (Block 3E)

This menu is used to allow manual actuator operation with the HART® communicator. There are three manual operation procedures available:

1. **Op mode** (Block 4G) - This procedure allows the user to select the operating mode of the DCM-3. There are four possible choices: "Follow", "Hold", "Stay" and "Stop". The "Follow" mode is the normal state of operation and allows the DCM-3 to control the actuator operation by responding to the analog input Demand signal when the actuator Handswitch is in the automatic position. The "Hold" mode causes positioning according to the HART Interface Demand Value. The "Stay" mode causes the output shaft to remain stationary and maintain its present position. Note that in "Stay" mode, the Handwheel cannot be freely turned. The "Stop" mode removes power from the motor. Note that in "Stop" mode the Handwheel can be freely turned. All operating modes can be overridden by the actuator Handswitch.
2. **Demand** - This procedure sets the effective Demand signal. If **Op mode** is set to "Hold", entering a valid value (-5% to 105%) will control the motor. If **Op mode** is set to "Follow", the value will follow the Demand analog signal (unless an alarm condition exists).
3. **Reset Stall** - This procedure resets normal actuator operation after a stall condition has caused the actuator to shut down. Selecting this option and following the prompts will restore operation. Note that stall conditions can also be reset by simply reversing the input Demand signal or cycling the actuator ac power.

HART INTERFACE Communication

Diagnostics Menu (Block 3F)

This menu provides access to all the DCM-3 stored online diagnostic information about actuator operation. The menu provides six submenus accessing actuator statistics and online actuator status.

Status Submenu (Block 4H)

This menu provides access to six submenus displaying various actuator status settings: LED Status, Operating Status, Switch Status, Local Cntrl Status, RET Inhibitors, and EXT Inhibitors.

LED Status Submenu (Block 5B)

This menu displays the ON or OFF status of each of the LEDs on the DCM-3. See below.

LED NAME	HART NAME	DESCRIPTION
STAT	"Status"	"On indicates that an operating condition is inappropriate see Operating Status menu"
REV	"Reverse"	"ON indicates that the Demand signal is less than the Position signal"
FWD	"Forward"	"ON indicates that the Demand signal is greater than the Position signal"
DEM_ERR	"Demand"	"ON indicates that a Demand error condition exists check the operating mode settings"
POS_ERR	"Position"	"ON indicates that the Position signal may be out of range or saturated"
TORQ_ERR	"Trq/Thrust"	"ON indicates that the Thrust or Thrust sensor signal may be out of range or saturated"
STALL_ERR	"Stall"	"ON indicates that the motor may be stalled"
TEMP_ERR	"Temperature"	"ON indicates that a temperature fault exists"
FB_ERR	"FB Open"	"ON indicates that the feedback loop is open or out of range"
STOP_ERR	"Limit"	"ON indicates that a limit switch has been triggered"
ACKN_ERR	"Acknowledge"	"Acknowledge indicator is active"

Operating Status Submenu (Block 5C)

This menu displays the ON or OFF status of eight actuator parameters. See below.

CONDITION	DESCRIPTION
DEMAND_LOS	"The Demand Signal is outside of the intended limits (see Demand Setup menu)"
TRQ_THRUST_OVERRANGE	"The Thrust is greater than the output rating"
STALL	"Stall condition has been detected (see General Setup menu)"
OVERTRQ_THRUST_PROTECTION	"Motor power has been removed due to excessive output thrust"
STOP_OR_LIMIT	"Motor power is blocked check switches"
FEEDBACK_DISCONNECTED	"The Feedback signal is enabled but the loop is open"
TEMPERATURE_OVERRANGE	"The temperature is outside of -40F to 185F"
POSITION_OVERRANGE	"The Position signal is less than -5% or greater than 105%"

Switch Status Submenu (Block 5D)

This menu displays the ON or OFF status of the eight switch parameters: LV Lim EXT, LV Lim RET, OvrRd EXT, OvrRd RET, OvrRd Stop, HndSw EXT, HndSw RET, and HndSw AUTO. The Switch Status menu displays the status of the RET/EXT control override input, the STOP control override or if the Handswitch is in the RET/EXT or AUTO position.

Local Control Status Submenu (Block 5E)

This menu displays the ON or OFF status of five local interface actuator parameters: Calibrate, Set Pos 100%, Set Pos 0%, Set Dem 100%, and Set Dem 0%. The Local Control Status submenu indicates which buttons on the Local Control board are pressed.

RET Inhibitors Submenu (Block 5F)

This menu displays the ON or OFF status of the contributing sources of retract movement inhibitors of motor operation: Balance, Supervisory, Stall, OverTrq/Thr, Switch Block, Bad Pos Sig, Bad Dem Sig, Local Cal. See below.

CONDITION	DESCRIPTION
Balance	"ON indicates that the Demand and Position are at balance"
Supervisory	"ON indicates that the DCM is initializing"
Stall	"ON indicates a Stall condition"
OverTrq/Thr	"ON indicates that the motor is stopped due to excessive thrust"
Switch Block	"ON indicates that the Handswitch, Override, or Limit Switch is inhibiting movement"
Bad Pos Sig	"ON indicates that the Position signal is out of range"
Bad Dem Sig	"On indicates that the Demand signal is out of range"
Local Cal	"ON indicates that a Local Calibration button is pressed"

EXT Inhibitors Submenu (Block 5G)

This menu displays the ON or OFF status of the contributing sources of extend movement inhibitors of motor operation: Balance, Supervisory, Stall, OverTrq/Thr, Switch Block, Bad Pos Sig, Bad Dem Sig, Local Cal. See table above.

Tests Submenu (Block 4I)

This menu provides procedures that allow the user to test, identify and reset the DCM-3 board. They are as follows:

1. **FB out test** - This procedure allows the user to test the 4–20 mA position feedback output signal. Following the prompts through this procedure allows the user to physically verify the output signal value at 4 mA, 20 mA, and anywhere in between.
2. **Board self-test** - This procedure runs an automatic board test that verifies the health of the DCM-3 control board. It runs a checksum memory test and checks for the proper installation of the position sensor (CPS rotor). Running the test causes the actuator to reposition temporarily, so it should only be run offline. The CPS test runs automatically as part of some calibration and setup procedures. This test should be implemented only if a DCM-3 problem is suspected.

3. **Identify Device** - This command will cause the Acknowledge LED to blink for two seconds. Used to verify proper HART communications as well as an aid in identifying which actuator is being addressed when configuring multiple actuators for split range operation.
4. **Board reset** - This procedure resets the board without powering down the actuator. There are many communicator procedures that implement the reset procedure automatically to ensure the proper initialization of the DCM-3 board; however, manually implementing the reset procedure is not typically necessary.

RET Thrust Submenu (Block 4J)

This menu displays the thrust applied over ten segments of travel of the actuator shaft.

EXT Thrust Submenu (Block 4K)

This menu displays the thrust applied over ten segments of travel of the actuator shaft.

Alarm Setup Submenu (Block 4L)

This menu allows customization of alarm indication:

1. **AlarmPol** - This determines whether the alarm relay "Drops Out" or "Pulls In" to indicate an alarm.
2. **Alarm Mask** - This leads to a submenu where alarm conditions may be set.

Alarm Mask Submenu (Block 5H)

This menu allows alarm conditions to be ignored; such as DemandLOS, Stall FeedbackLOS, or other conditions which may occur under normal operation and that may prove a nuisance during normal HART operation.

HART INTERFACE Communication

RealTimeClock Submenu (Block 4M)

This menu allows the date and time to be set. The settings are as follows:

1. **RTC Day** - Numerical entry sets the day of the month.
2. **RTC Month** - Numerical entry sets the month.
3. **RTC Year** - Numerical (4 digit) entry sets the year.
4. **Hour (24)** - Numerical entry sets the hour of the day (1–24).
5. **Minute** - Numerical entry sets the minute of the hour.

Calibration Trim Menu (Block 3G)

This menu displays/sets actuator calibration values:

1. **PresCPS V** - Displays the present value of the internal Position Sensor voltage. This value can also be measured at TP4(+) and TP1(–) on the DCM-3 board. This value can be edited to trim the Position Sensor.
2. **Loop(Dem)** - Displays the Demand signal as measured at the field wiring terminals. When the Demand control loop signal is being overridden by a special mode of operation, the effective Demand will not correspond to the mA value. This value can be edited to trim the Demand to ensure accurate measurement of the analog signal. Demand can only be trimmed at 4.0 mA and 20.0 mA.
3. **Feedback** - Displays the mA signal representing the output shaft position as measured at the field wiring terminals. This value can be edited.
4. **Thrust** - Displays the load measured at the output shaft as a percentage. This value can be edited.

HART INTERFACE Alarm Messages

COMMON HART® MESSAGES

HART® protocol maintains both standard and device specific informational messages that are displayed on the 475 Handheld Communicator when various conditions occur. They can also be used to trigger alarms and messages in other

HART® compatible monitoring systems. These messages alert the user to various alarm conditions and make it much easier to diagnose problems. Below is a table of typical Beck actuator messages and message sequences. It does not include all possible messages, only the most common.

Handswitch and Limit Switch Messages

Message	Description
"Motor power is blocked, check switches"	This message will appear if a condition prevents current flow to the motor. Some of the most common conditions are: The actuator Handswitch is put in the STOP position; either of the actuator over-travel limit switches are open; or the motor control triacs fail.

Demand Signal and Process Variable Messages

Message	Description
"Process applied to the non-primary variable is outside the operating limits of the field device"	This is a standard HART®-defined message that appears whenever one of the three HART® non-primary variables (Demand signal, Thrust, Temperature) are outside their design or calibrated ranges. The Demand input signal to the actuator is typically the problem source; however, the message can also appear if either the thrust measurement (optional) or temperature measurement is outside the design or calibrated ranges. The Beck specific messages below provide more descriptive information.
"The Demand Signal is outside of the intended limits (see Demand Setup menu)"	This is a Beck-specific message that can appear after the HART®-defined message above. It specifically pinpoints the Demand input signal to the DCM-3 as the problem source, and indicates that the signal is outside the calibrated range limits. The lower limit is configurable as a percentage of the calibrated range (default is -5%). The upper range is the highest readable input voltage (5.5 VDC) expressed as a percentage of the calibrated range (e.g., approximately 112% for a 4–20 mA* or 1–5 V dc standard input range).
"Demand out of accurate measurement range"	This is a Beck-specific message that can appear after the "Demand signal out of range" message above. It further defines the demand signal problem by indicating that the signal is not only out of the calibrated range, but also out of the design range of the actuator. The lower and upper limits are 0.1 V dc and 5.55 V dc respectively.*

*Note that current input DCM-3 boards utilize a 250 Ohm input resistor to convert the current signal to voltage.

HART INTERFACE Alarm Messages

Demand Signal and Process Variable Messages (con't)

Message	Description
"The Torque/Thrust is greater than the output rating"	This is a Beck-specific message that can appear after the HART®-defined ("Process applied to the non-primary variable is outside the operating limits of the field device") message mentioned previously. It serves to further define the condition, and indicates that the actuator's thrust output is exceeding 105% of the calibrated thrust range of the actuator.
"Motor power has been removed due to excessive output thrust"	This Beck-specific message appears after the "Thrust is excessive" message if the thrust measurement has exceeded 150% of the calibrated range and thus gone into a protective mode of operation to prevent excessive thrust in the event of an obstruction or other problem. The actuator ceases driving against the load until the condition is reset. Although unlikely, it is possible to also get a "Actuator in stall" message (see misc. messages) with this message.
"The temperature is outside of -40F to 185F"	This is a Beck-specific message that can appear after the HART®-defined ("Process applied to the non-primary variable is outside the operating limits of the field device") message mentioned previously. It serves to further define the condition, and indicates that the actuator's internal temperature is outside the -40° to 195°F (-40° to 91°C) range.
"Demand Signal is out of limit"	The Demand Signal has exceeded its measurable limits and has entered saturation. The value reported for Demand does not reflect the actual value.
"Loop Current Detected while under HART/FF Control"	This is a Beck specific alarm message that alerts the user that analog current is present on the Demand terminals while operating the actuator using the HART configurator Manual Operation menu. It is used to avoid confusion when a board is left in one of the manual operation modes and is not properly restored to "FOLLOW" mode.
"Loop Current Detected while set for LOS PAT"	PAT mode (Proportional mode) is a special Demand mode where discrete logic inputs are used in place of the Analog Demand signal. When operating in PAT mode, no Demand current should be present. If current is detected, this alarm will be asserted.

Position Signal Messages

(The position signal is defined as the signal from the position sensor (CPS) to the DCM-3)

Message	Description
"Process applied to the primary variable is outside the operating limits of the field device"	This is a standard HART®-defined message that appears whenever the HART® primary variable (Position signal) is outside the design or calibrated range. The DCM-3 is designed to accept a maximum position signal range of 0.25 to 5.35 V dc, and can be calibrated anywhere within this range depending on the type of CPS and desired stroke of the actuator. Normally, new actuators would be calibrated for a 1–5 V dc position signal. Retrofit applications are typically calibrated for a 0.45–2.6 V dc range.

Message	Description
"Analog output 1 and its digital representation are outside the operating range limits, and not responding to input"	This is an additional standard HART®-defined message that appears whenever the HART® primary variable (Position signal) is outside the design or calibrated range. It accompanies the message above.
"The Position Signal is less than -5% or greater than 105%"	This is a Beck-specific message that appears after the HART®-defined messages above. It specifically pinpoints the position signal to the DCM-3 as the problem source, and indicates that the signal is outside the calibrated range limits. The upper and lower limits are -5% and 105% of the calibrated range respectively.
"Position signal in LOS"	This is a Beck-specific message that appears after the HART®-defined messages above. It specifically pinpoints the position signal to the DCM-3 as the problem source, and is intended to indicate a CPS or wiring failure. The message is triggered when the position signal is outside the minimum and maximum limits of 0.25 V dc and 5.35 V dc respectively. In this case, the LOS message above will also be present.
"Position out of accurate measurement range"	This is a Beck-specific message that appears after the HART®-defined messages previously mentioned. It specifically pinpoints the position signal to the DCM-3 as the problem source, and indicates that the signal is outside the 0.25–5.35 V dc design range. The LOS message above will also be present when this message is present.

Miscellaneous Messages

Message	Description
"The Feedback Signal is enabled but the loop is open"	This is a Beck-specific alarm message that alerts the user that external position feedback signal is installed and enabled, but not wired to an external load. If the signal is wired to an external load and this message appears, it implies that a wiring failure somewhere between the actuator and the monitoring device has occurred. If the DCM-3 board is equipped with the feedback module, but the signal is not being used, this message can be eliminated by disabling the feedback in the configuration.
"Stall condition has been detected (see 'Stall Time' in the 'General Setup' menu)"	This is a Beck-specific alarm message alerting the user that the actuator is in a stalled condition and is no longer trying to fight the load. This condition occurs if the actuator cannot reach the demand position in the time allotted by the stall time setting (configurable from 30–300 seconds, default 300 sec.). In actuators equipped with optional torque measurement, this message may not occur due to the pre-emptive action of overtorque protection.
"Feedback is in fixed mode"	The "FB Out Test" diagnostic allows the user to set Feedback to a fixed value, rather than the normal mode of having Feedback follow the Position value. If the Feedback value is left in the "fixed" mode, this error will be reported to alert the user that Feedback is not following the Position value.

LOCAL INTERFACE Configuration & Setup

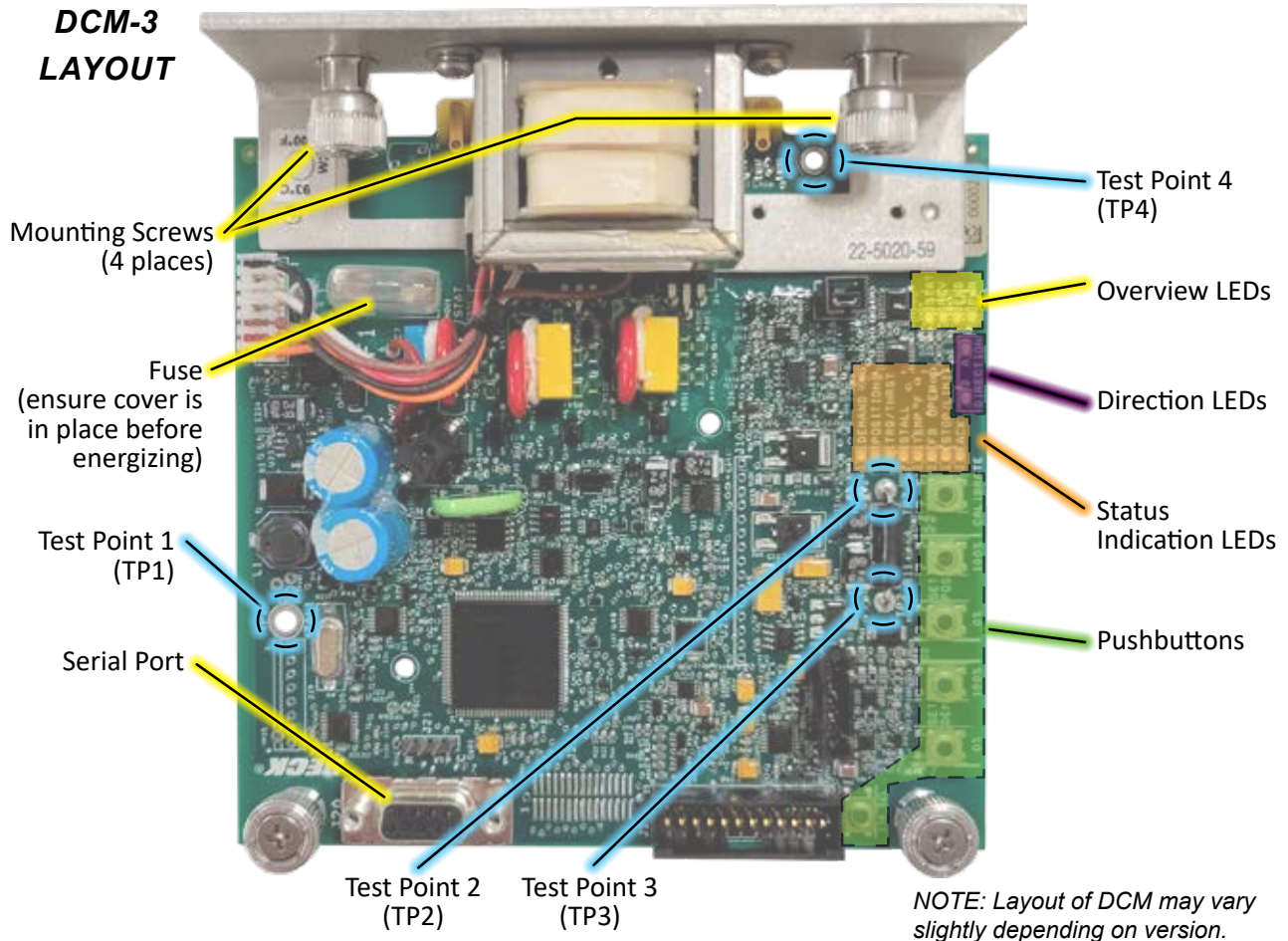

OVERVIEW LEDs

Located on the DCM-3 board (pictured above), these LEDs indicate the basic, real-time state of the actuator. A description of each LED follows.

STAT

This red LED illuminates during a system alarm. Explanation of the specific alarm is available through the Fieldbus or Serial interface. See the Troubleshooting section for additional information.

REV

This green LED illuminates when the actuator is receiving a Demand signal less than its position.

FWD

This green LED illuminates when the actuator is receiving a Demand signal greater than its position.

PWR

This green LED illuminates when power is applied to the actuator. This LED pulses from bright to dim indicating the DCM-3 is operational.



DIRECTION LEDs

These green LEDs indicate the direction of travel resulting from an increasing Demand signal.



A = EXT B = RET

STATUS INDICATION LEDS

When the "STAT" LED is lit, the applicable red indication LED(s) will light to reveal the actuator condition(s). An alarm is also available at terminal E. When the condition is corrected, the status will automatically reset.

DEMAND

Loss of the Demand input signal.

POSITION

The Position signal to the DCM-3 is out of the calibrated range limits. The lower limit is -5% and the upper limit is 105% of the calibrated range. May also indicate a film potentiometer or internal wiring failure.

TRQ/THRST

Indicates thrust has exceeded 150% of drive rating (configurable).

STALL

The actuator is in a stall condition and stall protection has been activated.

TEMP °F.

Actuator's internal temperature is outside of rating.

FB OPEN

External position Feedback signal is enabled, but not wired to an external load or the wiring has failed between the actuator and the monitoring device.

STOP/LIMIT

Handswitch is in "STOP" position or the actuator is at a limit and is not in balance.

ACK

Acknowledges when a calibration procedure has been completed.

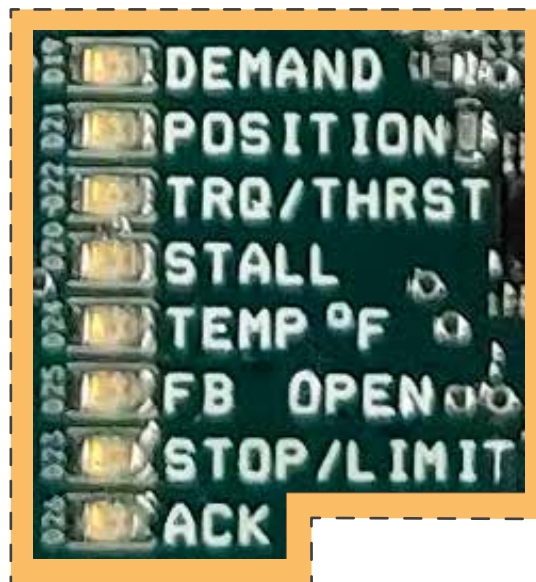

PUSHBUTTON CONTROLS

The five pushbuttons (pictured below) on the DCM-3 customer interface panel are used for calibration. When pressing a pushbutton, pressure should be maintained until the "ACK" LED is lit; this confirms receipt of the pushbutton command. See the Configuration/Calibration section of this manual for further explanation of calibration procedures.

CALIBRATE

This button must be pressed and held simultaneously with another pushbutton to perform a calibration.

SET POS 100%

Press to designate the current position of the output shaft as the 100% position for actuator movement (this will correspond to a 100% Demand signal).

SET POS 0%

Press to designate the current position of the output shaft as the 0% position for actuator movement (this will correspond to a 0% Demand signal).

SET DEM 100%

Press to designate the current Demand input signal as 100% Demand.

SET DEM 0%

Press to designate the current Demand input signal as 0% Demand.

DIR SEL

Press to change the direction in which the output shaft will rotate in response to an increasing Demand signal. The opposite direction LED will light (see p.24) when the pushbutton command is confirmed.



CAUTION

Pressing the following buttons may change calibration and cause the actuator to reposition.

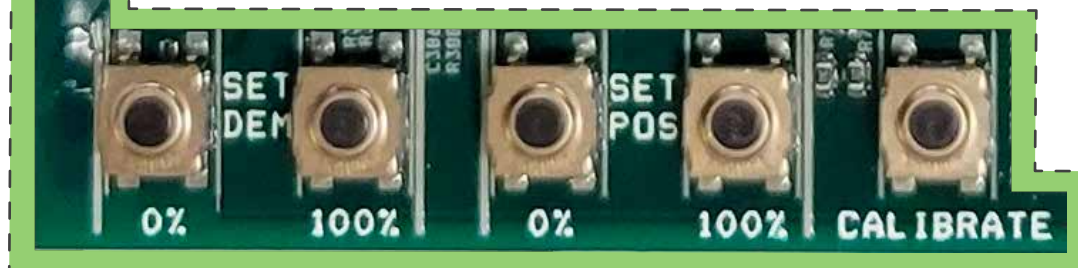

LOCAL INTERFACE Configuration & Setup

LOSS OF DEMAND INPUT SIGNAL (L.O.S.)

When the Demand input signal drops to approximately 3.2 mA (~5% of span below the minimum signal), the DCM-3 considers the Demand input signal to be invalid. DCM-3s are typically configured to stop the actuator during L.O.S. conditions, but may be configured to run the actuator to a predetermined position (GTP or Go To Position). If GTP is selected, a time delay before movement to that position may be set, also (see page 53). Under the L.O.S. condition, the "STAT" and "DEMAND" LEDs will light and an alarm condition will result at terminals 9, 10 and 11 (see page 12). When the input signal is corrected, the actuator will automatically resume normal operation.

POSITION: CONTACTLESS POSITION SENSOR (CPS)

The CPS provides the DCM-3 with a continuous feedback signal proportional to the position of the actuator's output shaft.

The position sensing function of the CPS is provided by a ferrite magnetic sensing element. An electronic circuit translates the signal from the ferrite magnetic sensor into a position signal used by the DCM-3 to control the actuator. The typical output voltage of the CPS ranges from 1.034 V at the EXT end of travel, to 3.966 V at the RET end of travel. This specific signal is not available for external connections. If the Position signal is outside the anticipated range, the "STAT" and "POSITION" LEDs will light, and an alarm condition will result at terminals 9, 10 and 11 (see page 12). When the Position signal is corrected, the actuator will automatically resume normal operation.

THRUST PROTECTION

DCM-3s are equipped with a thrust sensing module that will light the "STAT" and "TRQ/THRST" LEDs in the event excessive thrust is detected, and an alarm condition will result at terminals 9, 10 and 11 (see page 12). This alarm is normally set to activate when thrust exceeds 105% of the actuator rating. Thrust above 150% of the actuator rating will cause the DCM-3 to prevent the actuator from operating in the direction of the high thrust. When the over-thrust condition is corrected, the actuator will automatically resume normal operation.

STALL PROTECTION AND ANNUNCIATION

If the actuator output shaft cannot reach a desired position within the configured time, the DCM-3 shuts off power to the motor and the "STAT" and "STALL" LEDs will light, and an alarm condition will result at terminals 9, 10 and 11 (see page 12). The stall condition timing is factory configurable from 300 seconds to as low as 30 seconds and is set according to the specification at time of order (factory default setting is 300 seconds).

A sensed stall condition is cleared by either reversing the Demand input signal from the controller (such that the actuator tries to run in the direction opposite the blocked direction) or switching the actuator power off and on. When the stall condition is cleared, the actuator will automatically resume normal operation.

TEMPERATURE

DCM-3s are equipped with a temperature sensing circuit. The "STAT" and "TEMP °F" LEDs will light when the actuator's ambient temperature exceeds the rating of the actuator (185°F. / 85°C.), and an alarm condition will result at terminals 9, 10 and 11 (see page 12).

FEEDBACK SIGNAL

A feedback sourcing module in the DCM-3 provides a 4–20 mA analog output signal that represents the actuator output shaft position in terms of 0–100% of full rotational travel. This signal can be remotely monitored or used by a controller or indicator. The "STATUS" and "FB OPEN" LEDs will light if the function is enabled and there is no current in the loop, and an alarm condition will result at terminals 9, 10 and 11 (see page 12). Using the serial interface, the Feedback signal may also be set for reversed (decreasing direction) of travel, where the typical 4 mA value represents 100% of travel and 20 mA, 0% travel (see page 54, "fdbk0pctma" & "fdbk100pctma").

The Feedback signal can be disabled at the factory or in the field using the DCM-3 HART or serial interface.

STOP/LIMIT INDICATION

The "STAT" and "STOP/LIMIT" LEDs will light if the actuator is at a limit and is not in balance.

LOCAL INTERFACE Calibration (Demand)

DCM-3 boards are designed to accept a 4–20 mA (or 1–5 V dc) analog Demand signal. Narrower spans within this range can also be accommodated for split range operation (see page 44). The input comes calibrated from the factory for the full range, unless otherwise specified by the customer. It is not necessary to calibrate the Demand input when the actuator is installed; however, it can be easily accomplished using the pushbutton controls and a signal source. Following this procedure is only necessary if the factory settings are inappropriate.

Calibration Procedure

1. Remove the cover (see outline dimensions beginning on page 8).
2. Ensure the Handswitch is in the “STOP” position. This will prevent the actuator from repositioning during this procedure.
3. Apply the desired 0% Demand input signal to the actuator (e.g., 4 mA for 4–20 mA input).
4. Press and hold the “CALIBRATE” pushbutton on the DCM-3, then press the “SET DEM 0%” pushbutton until the “ACKNOWLEDGE” LED is lit.*
5. Apply the desired 100% Demand input signal to the actuator (e.g., 20 mA for 4–20 mA input).
6. Press and hold the “CALIBRATE” pushbutton on the DCM-3, then press the “SET DEM 100%” pushbutton until the “ACKNOWLEDGE” LED is lit.*
7. Turn the Handswitch to the “AUTO” position.
NOTE: The actuator may reposition.
8. Run the actuator through its full operating range to ensure proper response to the Demand input signal.
9. Replace the cover and tighten the cover bolts to 14 lb-ft (19 N•m) torque.

* If the “ACKNOWLEDGE” LED does not light, but the “DEMAND” LED does light, the signal is out of acceptable range and was not accepted by the DCM-3. This is typically caused by trying to set 0% and 100% values too closely together (i.e., less than 4 mA difference).

LOCAL INTERFACE Calibration (Demand)

SPLIT RANGE OPERATION

In applications where it is necessary (or preferable) to have more than one final control element controlling a single process, two to four Beck actuators may be set up to respond to different portions of the Demand signal from the control system. The most common arrangement involves two actuators; each operating on different halves of the input signal range. For example, if a 4–20 mA control signal is used, the first actuator would move 100% of its stroke on a signal range of 4–12 mA, while the second operates on the 12–20 mA range.

To set up a split range operation, follow the steps listed below (see page 41 for location of pushbutton controls).

1. Remove the cover (see outline dimensions beginning on page 8).
2. Ensure the Handswitch is in the “STOP” position. This will prevent the actuator from repositioning during this procedure.
3. Apply the desired 0% Demand input signal to the actuator. (Following the example above, the minimum signal for the first actuator would be 4 mA. The second actuator’s minimum signal would be 12 mA).
4. Press and hold the “CALIBRATE” pushbutton, then press the “SET DEM 0%” pushbutton until the “ACKNOWLEDGE” LED is lit.*
5. Apply the desired 100% Demand input signal to the actuator. (Following the example above, the maximum signal for the first actuator would be 12 mA. The second actuator’s maximum signal would be 20 mA).
6. Press and hold the “CALIBRATE” pushbutton, then press the “SET DEM 100%” pushbutton until the “ACKNOWLEDGE” LED is lit.*
7. Repeat this process for the remaining actuators to be split-ranged.
8. Run the actuator through its full operating range to ensure proper response to the Demand input signal.
9. Replace the cover. Tighten the cover bolts to 14 lb-ft (19 N•m) torque.

* If the “ACKNOWLEDGE” LED does not light, but the “DEMAND” LED does light, the signal is out of acceptable range and was not accepted by the DCM-3. This is typically caused by trying to set 0% and 100% values too closely together (i.e., less than 4 mA difference).

SQUARE FUNCTION

Beck actuators can be set-up to position the output shaft proportionally to the square of the input signal (see table below). This function is factory configurable, or can be configured in the field using the HART or serial interface.

Input Signal (mA)	Standard Output (% of Span)	Square Function Actual Output Position (% of Span)
4.0	0	0
5.6	10	1
12.0	50	25
15.2	70	49
18.4	90	81
20.0	100	100

LOCAL INTERFACE Calibration (Position)

In order to correctly position the actuator output shaft in response to the Demand input signal, the DCM-3 receives a position signal from the actuator's position sensor and compares this actual position to the Demand input. This process requires that the DCM-3 interprets the position signal appropriately for the full range of desired travel. This procedure will calibrate the DCM-3 to accept the position signal and interpret the appropriate 0–100% range.

Calibration Procedure

1. Remove the cover (see outline dimensions beginning on page 8).
2. Position the actuator at the desired minimum position (i.e., the desired physical position of the actuator's output shaft corresponding to the 0% Demand input signal).
3. Ensure the Handswitch is in the "STOP" position. This will prevent the actuator from repositioning during this procedure.
4. Press and hold the "CALIBRATE" pushbutton on the DCM-3, then press the "SET POS 0%" pushbutton until the "ACKNOWLEDGE" LED is lit.*
5. Position the actuator at the desired maximum position (i.e., the desired physical position of the actuator's output shaft corresponding to the 100% Demand input signal).
6. Ensure the Handswitch is in the "STOP" position. This will prevent the actuator from repositioning during this procedure.
7. Press and hold the "CALIBRATE" pushbutton on the DCM-3, then press the "SET POS 100%" pushbutton until the "ACKNOWLEDGE" LED is lit.*
8. Verify that the actuator's 0% and 100% positions are correct. If not, repeat this procedure.
9. Replace the cover and tighten the cover bolts to 14 lb-ft (19 N•m) torque.

* If the "ACKNOWLEDGE" LED does not light, but the "POSITION" LED does light, the signal is out of acceptable range and was not accepted by the DCM-3.

SHORT-STROKE OPERATION (Reducing Full Travel)

Typically, it is best to use the full travel of the actuator in response to the 0–100% Demand input signal. However, in certain applications it may become necessary to reduce this response to less than full travel. In these applications, the DCM-3 can be calibrated to accommodate reduced stroke. The minimum full stroke travel is 45% (although travel this short is not recommended—it is ideal to make the range as close to 100% as possible for the highest position resolution attainable with the CPS).

Reducing the full travel is referred to as "short-stroking" the actuator. This can be accomplished by using the DCM-3 customer interface panel.

LOCAL INTERFACE Calibration (Direction Change)

DIRECTION OF OUTPUT SHAFT TRAVEL (RET vs. EXT)

The direction of output shaft travel is determined by observing the output shaft (see illustration below). Direction of travel is defined as the direction of output shaft travel produced by an increasing Demand signal. Unless otherwise specified at the time of order, the output shaft is factory set to retract in response to an increasing signal.

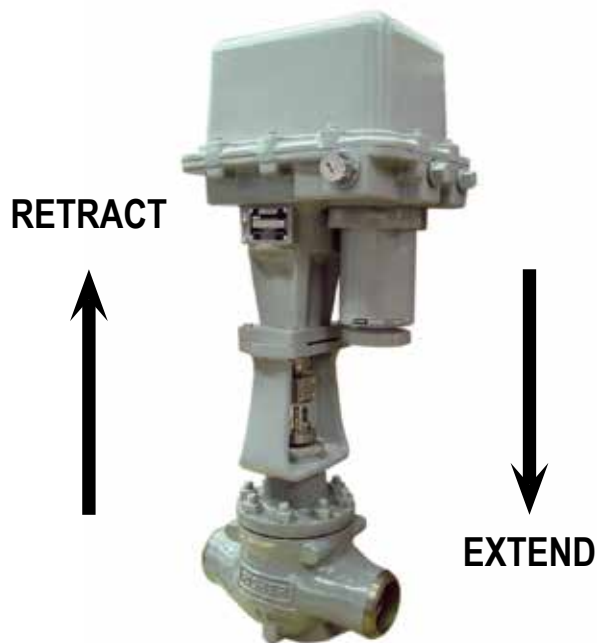

Direction of travel in response to an increasing Demand signal

Changing the direction of output shaft travel is easily accomplished using the DCM-3 local interface (see page 43 for location of pushbutton controls). Follow the steps below.

1. Remove the cover (see outline dimensions beginning on page 8).
2. Press and hold the "CALIBRATE" pushbutton, then press the "DIR SEL" pushbutton until the (opposite) "DIRECTION" LED is lit.

—OR—

2. Position the actuator at the current 0% position.
3. Press and hold the "CALIBRATE" pushbutton, then press the "SET POS 100%" pushbutton until the "ACKNOWLEDGE" LED is lit.*

—OR—

2. Position the actuator at the current 100% position.
3. Press and hold the "CALIBRATE" pushbutton, then press the "SET POS 0%" pushbutton until the "ACKNOWLEDGE" LED is lit.*
4. Ensure the actuator operates as desired.
5. Replace the cover and tighten the cover bolts to 14 lb-ft (19 N•m) torque. Reset travel index.

* If the "ACKNOWLEDGE" LED does not light, but the "POSITION" LED does light, the change was not accepted by the DCM-3.

NOTE: When any of the above procedures is performed, both the 0% and 100% positions are automatically set.

SERIAL INTERFACE Configuration & Setup

COMMUNICATIONS

The Beck Digital Control Module (DCM-3) is equipped with a Serial interface which allows for direct communication with a computer. Using a standard DB9 to USB cable, connect the DCM-3 to the computer using the DCM-3's DB9 connector (see below for location) and one of the computer's USB ports. Note: If your computer is equipped with an active COM port, a DB9 to DB9 cable may be utilized. See below for part numbers of cables available from Beck.

Once connected, communication can be established between the DCM-3 and the computer using a terminal emulation program, such as HyperTerminal®. This method of communication will allow for configuration, calibration and verification of actuator DCM-3 settings without the use of custom software applications.



DB9
Connector

Beck Serial Communications Cables



DB9 to USB-A
P/N 20-0511-60



DB9 to DB9
P/N 20-0511-14

*Note cables may differ in appearance from depiction.

SERIAL INTERFACE Configuration & Setup

HYPERTERMINAL® SOFTWARE

HyperTerminal is the standard ASCII terminal emulation software provided with Microsoft® Windows®. If using HyperTerminal, the following instructions will assist in setup. Note that some variation to these instructions may be necessary depending on the version of HyperTerminal being used.

Once the computer has been plugged into the DCM-3, access HyperTerminal by clicking first on "Start", then "Programs", then "Accessories", then "Communications", then "HyperTerminal".

Double-click on the "Hypertrm.exe" icon to start the program. Once HyperTerminal is running, it is necessary to set up a file with the proper settings to communicate with the DCM-3. Proceed as follows:

1. If prompted to install a modem, answer "no". Proceed to enter a name (e.g., "DCM-3") and select an icon (any will suffice) in the "Connection Description" box. Click the "OK" button.
2. The "Connect to" box should open next. At the bottom of the box, set the "Connect using" selection to the computer COM port that has been connected to the DCM-3. Click the "OK" button.
3. The COM port properties box should open next. This is where the communication settings are established. The correct settings are:
 - a. Bits per second = "1200"
 - b. Data bits = "8"
 - c. Parity = "none"
 - d. Stop bits = "1"
 - e. Flow control = "none"
4. With the appropriate settings entered from Step 3, above, click "OK". Communications should now be enabled.
5. Press the "Enter" key twice. "Ok" should be displayed indicating that HyperTerminal is communicating with the DCM-3.

COMMANDS AND ARGUMENTS

Commands can be used for a variety of functions, which include changing the operating configuration of the actuator, verifying operation settings, calibration, and accessing diagnostic information. There are essentially four different types of commands:

1. Dual-purpose commands. These commands can be used to either modify actuator configuration settings or display the settings already set in the actuator. In order to set or make a change to the settings, the command requires an argument (*n*). If the command is used for display purposes only, the argument is omitted. Examples of these commands include "deadband" and "demlos".
2. Display only commands. These commands are used to display diagnostic or operating information like present signal values. No arguments are required. Examples include the "stat" command and the "signals" command.
3. Set only commands. These commands serve only to make a parameter change. Typically, they apply to the actuator calibration. This type of command requires an argument, but unlike dual-purpose commands, they return an error message when entered without an argument. Examples include the "dem0pctma" and "posisp" commands.
4. Execute action commands. These commands serve to reset, enable or disable features. Entering these commands produces an immediate action. Examples include the "restoremodes" and "thrustenable" command.

The available commands are listed on page 51 and each is described in more detail on pages 52 through 56. The command description explains the use or uses of the command, while the argument column describes the applicable arguments for those commands that require them. In the command tables, arguments are denoted as *n*. Note that the commands described as "sets and/or displays" signify dual purpose commands that can be used with or without an argument for setting or verifying configuration settings.

SERIAL INTERFACE Commands

LIST OF SERIAL COMMANDS

The following is a list of serial commands available through the DB9 interface. Error codes associated with these commands are listed on page 56.

General Configuration Commands (p. 52)

- stepsize
- drvdir
- stalltime
- sernum

Reset Factory Settings Commands (p. 52)

- restoremodes
- harttype

Demand Signal Commands (p. 52 & 53)

- dem0pctma
- dem100pctma
- trimdem4ma
- trimdem20ma
- demfunc
- demlos
- demlosgtp
- demlosgtp delay

Position & Feedback Signal Commands (p. 54)

- posis
- fdbk0pctma
- fdbk100pctma
- trimfdbk4ma
- trimfdbk20ma
- fdbkfunc
- travel

Thrust Sensing Commands (p. 54 & 55)

- thrust0k
- thrustconst
- thrust0pct
- thrustenable
- ovtstop
- ovtstoplevel

Diagnostic and Information Commands (p. 55)

- signals
- stat
- tempf
- thrust

SERIAL INTERFACE Commands

Note: For specific information on the following functions, see the appropriate sections of the manual.

General Configuration Commands

Command	Description	Argument <i>n</i> and Information
drvdir <i>n</i>	Sets/displays the actuator output shaft direction resulting from an increasing Demand signal.	<i>n</i> = "0": Retract <i>n</i> = "1": Extend
sernum <i>n</i>	Sets the actuator Serial number.	<i>n</i> = Serial number
stalltime <i>n</i>	Sets/displays time the actuator runs in one direction before stall alarm is activated.	<i>n</i> = seconds: acceptable range is 30–450 seconds.
stepsize <i>n</i> %	Sets/displays the size of one incremental movement of the output shaft.	<i>n</i> = % of travel desired: acceptable range is 0.10%–2.5%. Include the "%" symbol after the number, otherwise the unit of measure will be inches.

Reset Factory Settings Commands

Command	Description	Argument <i>n</i> and Information
restoremodes 1	Resets the actuator configuration back to the original factory settings.	No additional argument required.
harttype <i>n</i>	Sets and/or displays the DCM-3 HART device type.	<i>n</i> = "1" (ESR-D); <i>n</i> = "10" (DCM-3); or <i>n</i> = "239" (BECK-MK2)

Demand Signal Commands

Command	Description	Argument <i>n</i> and Information
dem0pctma <i>n</i>	Sets the Demand signal value that corresponds to 0% actuator position.	<i>n</i> = the Demand signal as a decimal in milliamps. The minimum acceptable value is 0.50 mA. The maximum acceptable value is 100% Demand less 4.00 mA. For example, if the 100% Demand signal is 20.00 mA, then the 0% Demand signal must be 16.00 mA or less.
dem100pctma <i>n</i>	Sets the Demand signal value that corresponds to 100% actuator position.	<i>n</i> = the Demand signal as a decimal in milliamps. The minimum acceptable value is the Demand at 0% plus 4.00 mA. For example, if the 0% Demand signal is 4.00 mA, then the 100% Demand signal must be 8.00 mA or greater. The maximum acceptable value is 21.00 mA.
trimdem4ma 4	Calibrates the Demand signal at 4 mA. This command should only be used when the Demand signal at the actuator is 4 mA. If the Demand signal at the actuator is greater or less than 4 mA, an error will be returned. Note: This parameter is factory configured and normally does not require recalibration.	A 4 mA Demand signal must be present at actuator terminals 18 & 19.

Demand Signal Commands

Command	Description	Argument <i>n</i> and Information
trimdem20ma 20	Calibrates the Demand signal at 20 mA. This command should only be used when the Demand signal at the actuator is 20 mA. If the Demand signal at the actuator is greater or less than 20 mA, an error will be returned. Note: This parameter is factory configured and normally does not require recalibration.	A 20 mA Demand signal must be present at actuator terminals 18 & 19.
demfunc <i>n</i>	Sets and/or displays the Demand signal input characterization function. The DCM-3 provides linear, square root, special curve or square function characterization.	<i>n</i> = "0" (linear) <i>n</i> = "1" (square root) <i>n</i> = "4" (special curve) <i>n</i> = "5" (square).
demlos <i>n</i>	Sets and/or displays the Demand signal threshold below which the DCM-3 recognizes that the signal is lost. The threshold is entered as a value in mA. This command also sets and/or displays the action initiated by the actuator during LOS (Loss Of Signal). LOS action options are "sip" (stay in place) or "gtp" (go to position). Note that the command always reports both settings, but only sets one argument at a time. The command must be used twice to set the threshold and action. If the action is "gtp", then the command <i>demlosgtp</i> (see below) must also be set. The option "pat" is also available to prevent error messages if the DCM-3 is not being used with a Demand signal.	<i>n</i> = the Demand signal in mA below which LOS occurs. For example, in a 4–20 mA actuator, if the desired LOS is 5% below the minimum signal, then <i>n</i> = "3.20" mA. — OR — <i>n</i> = "sip", "gtp" or "pat". Note: <i>n</i> values must be set separately.
demlosgtp <i>n</i>	Sets and/or displays the position to which the actuator will run upon loss of the Demand signal (LOS). This command has no effect if the actuator is set to "sip" (stay in place).	<i>n</i> = the desired position of the actuator expressed as a percentage of actuator travel (e.g., if the desired LOS position is 50%, then <i>n</i> = "50.00").
demlosgtp delay <i>n</i>	Sets the time delay in seconds before the actuator will move to the position set in "demlosgtp". Entering this command without an argument will return the present gtp and delay settings.	<i>n</i> = time delay in seconds. Acceptable values are 0 (default) to 25.5.

SERIAL INTERFACE Commands

Note: For specific information on the following functions, see the appropriate sections of the manual.

Position and Feedback Signal Commands

Command	Description	Argument <i>n</i> and Information
travel <i>n</i>	Sets and/or displays the value that represents 100% travel.	<i>n</i> = the desired length of travel in degrees.
fdbk0pctma <i>n</i>	Sets and/or displays the mA value of the Feedback signal that represents the 0% actuator position. May also be set for decreasing direction of Feedback; i.e., see argument and information for "fdbk100pctma", but 0% would be the maximum value.	<i>n</i> = the desired Feedback signal for 0% actuator position in mA. The minimum value is 3 mA ("3.00") and the maximum value is at least 4 mA less than the Feedback signal value for the 100% actuator position.
fdbk100pctma <i>n</i>	Sets and/or displays the mA value of the Feedback signal that represents the 100% actuator position. May also be set for decreasing direction of Feedback; i.e., see argument and information for "fdbk0pctma", but 100% would be the minimum value.	<i>n</i> = the desired Feedback signal for 100% actuator position in mA. The minimum value must be at least 4 mA greater than the Feedback signal value for the 0% actuator position. The maximum value is 21mA ("21.00").
fdbkfunc <i>n</i>	Sets and/or displays whether or not the actuator Feedback signal is enabled.	<i>n</i> = "0" (no feedback) or "1" (feedback).
posis <i>n</i>	Sets the point of actuator travel in relation to the actuator's current position. This command should only be used when the actuator is at a known position of travel.	<i>n</i> = the present actuator position as a degree of full actuator travel to establish where the 0% point of travel should be.
trimfdbk4ma <i>n</i>	Trims the Feedback signal at 4 mA. If the Feedback signal is not within 1 mA of 4 mA, an error will be returned. Note: The Feedback sourcing circuit is factory calibrated and normally does not require recalibration.	<i>n</i> = the present Feedback signal from the actuator as measured in mA at terminals 16 & 17. The minimum value is 3 mA ("3.000") and the maximum value is 5 mA ("5.000").
trimfdbk20ma <i>n</i>	Trims the Feedback signal at 20 mA. If the Feedback signal is not within 1 mA of 20 mA, an error will be returned. Note: The Feedback sourcing circuit is factory calibrated and normally does not require recalibration.	<i>n</i> = the present Feedback signal from the actuator as measured in mA at terminals 16 & 17. The minimum value is 19 mA ("19.000") and the maximum value is 21 mA ("21.000").

Thrust Sensing Commands

Command	Description	Argument <i>n</i> and Information
thrust0k <i>n</i>	Assigns the count value to be associated with 0 thrust. This number is unique to each actuator.	<i>n</i> = the zero thrust value in counts. This number is determined during manufacture and is noted on a tag affixed to the actuator body within the electronics compartment.
thrustconst <i>n</i>	Assigns the count value to be associated with the thrust span. This number is unique to each actuator.	<i>n</i> = the thrust span value in counts. This number is determined during manufacture and is noted on a tag affixed to the actuator body within the electronics compartment.

Command	Description	Argument <i>n</i> and Information
thrustenable <i>n</i>	Enables or disables the thrust measurement feature of the actuator.	<i>n</i> = "0" (disabled) or "1" (enabled).
thrust0pct <i>n</i>	This is an alternate method for setting thrust0k and is useful when the correct thrust0k value is unknown. To use this command, remove all load from the output shaft, then execute thrust0pct with argument "0" to let the DCM-3 know that the thrust should be at 0%.	<i>n</i> = "0".
ovtstop <i>n</i>	Sets/displays whether motor power will be removed during severe overthrust conditions. Thrust sensing must be enabled.	<i>n</i> = "0" (disabled) or "1" (enabled).
ovtstoplevel <i>n</i>	Sets/displays the thrust magnitude associated with severe output shaft thrust conditions.	<i>n</i> = allowable thrust magnitude (without stopping motor) in percentage of actuator rating. May be set from 25% to 150% (factory setting is 150%).

Diagnostic and Information Commands

Command	Description	Argument <i>n</i> and Information
signals	Displays the present Position signal of the actuator in volts and the Demand signal in milliamps.	No argument.
stat	Displays information on the status of the actuator, including: Time / Date Demand (% and settings) Position (% / inches) Error (%) Stepsize (inches / %) Deadband (inches / %) Motor Status Run Time Line Frequency Starts (ext./ret./total) Reversals/Stalls Overloads Positive & Negative Peak Load (%) Positive & Negative Peak Thrust (% / inches) Extend and Retract Inhibit Setting Alarms	No argument.
tempf	Displays measured temperatures in the actuator (°F.): Low extreme Present temperature High extreme	No argument.
thrust	Displays the actuator's present thrust measurement as a percentage of rated thrust.	No argument.

SERIAL INTERFACE Commands

Command Error Codes

When an error is encountered using the serial commands, an "ERROR XX" message is returned. The table below provides a description of the error codes ("XX").

Code	Description	Information
2	Invalid selection	Displayed when an unknown command has been entered.
3	Value too big	Displayed when an entered numeric value exceeds expected parameters.
4	Value too small	Displayed when an entered numeric value is less than expected parameters.
5	Data length error	Displayed when the wrong number of arguments is entered.
6	General error	Displayed when a combination of circumstances prevents a better description of the error.
9	Process too high	Displayed when the entered value exceeds acceptable parameters when calibrating a 0% value.
10	Process too low	Displayed when the entered value is less than acceptable parameters when calibrating a 100% value.
14	Span too small	Displayed when entered values for a 0% point and a 100% point are too close.
32	Busy	Displayed when a memory store is requested and another memory store is already in process.
64	Not implemented	Displayed when an entered command is defined, but cannot be implemented.

MAINTENANCE

ROUTINE

Beck actuators require only a minimum of routine maintenance. A visual inspection is in order to verify that the connection to the final control element is intact and operating normally. If vibration is present, check the electrical terminal connections and fasteners for tightness.

Lubrication

Periodic lubrication is not required on Beck actuators. However, it is recommended that during major shutdowns or outages, the actuators in the most severe applications be inspected.



WARNING	
Disconnect power before proceeding.	
Before removing the motor assembly, block the valve stem to prevent the gear train from moving when the motor is removed.	

To inspect the gears, remove the motor assembly (5/16" bolt heads). Carefully pull the motor away from the actuator body (it will be necessary to remove the top cover and cut the wire tie which holds the motor wires in place). Remove all old lubrication from the accessible gearing. Examine the gear teeth and shafts for indication of excessive wear, scoring or other damage. If evidence of damage is present, the actuator should be returned to the factory for a detailed examination of all gearing, which requires complete disassembly of the actuator (see "HOW TO OBTAIN SERVICE" on the inside back cover).

If there is no evidence of damage to the gearing, recoat the teeth and shaft bores of all gears with a heavy layer of Mobiltemp SHC 32 or equivalent.

Carefully replace the motor. Tighten the motor bolts to 11 lb-ft (15 N•m) torque. Rebundle the motor wires with a wire tie. Replace the top cover and tighten cover bolts to 14 lb-ft (19 N•m) torque.

MOTORS, RESISTORS, & CAPACITORS

Model Number	Motor					Capacitor		Resistor	
	Part Number	Current (Amps at 120 Vac, 60 Hz ^b)	Torque (N•m)	RPM	Freq. (Hertz)	Part Number	Value (µf)	Part Number	Value (Ω)
29-10_	20-2703-46	.71	3.3	72	60	14-2840-05	8	20-1971-32	110 ^a
					50	14-2840-30	13	20-1971-32	110 ^a
29-25_	20-2703-47	1.2	6.0	72	60	14-2840-17	15	20-1971-33	55 ^a
					50	14-2840-22	21	20-1971-33	55 ^a
29-60_	20-2201-42	1.3	7.0	72	60	14-2840-17	15	20-1971-34	75 ^a
					50	14-2840-23	20	20-1971-34	75 ^a
	20-2201-46	2.3	14.0	72	60	14-2840-15	25	20-1971-35	37.5 ^a
					50	14-2840-24	33	20-1971-35	37.5 ^a
	20-2201-43	3.3	14.0	120	60	14-2840-33	31	20-1971-37	18 ^a
					50	14-2840-32	39	20-1971-36	24 ^a

^a This is a resistor assembly.

^b 50 Hz currents do not exceed 120% of the 60 Hz levels.

MAINTENANCE

COMPONENT REPLACEMENT

The following table lists the components of the Group 29 actuator that are field-replaceable. Each of these components is available as a customer replacement kit, which includes the component(s), necessary hardware and detailed instructions.

CUSTOMER REPLACEMENT KITS / PARTS

Customer Kit / Part	Part No.
3.0 N•m Motor w/ SLM (Motor 20-2703-46)	20-2703-46-KIT
Resistor/Capacitor (60 Hz)	12-8063-11
Resistor/Capacitor (50 Hz)	12-8063-12
Self Locking Mechanism (SLM)	12-8063-34
6.0 N•m Motor w/ SLM (Motor 20-2703-47)	20-2703-47-KIT
Resistor/Capacitor (60 Hz)	12-8063-13
Resistor/Capacitor (50 Hz)	12-8063-14
Self Locking Mechanism (SLM)	12-8063-24
7.0 N•m Motor w/ SLM (Motor 20-2201-42)	20-2201-42-KIT
Resistor/Capacitor (60 Hz)	12-8063-15
Resistor/Capacitor (50 Hz)	12-8063-16
Self Locking Mechanism (SLM)	12-8063-44
14.0 N•m Motor w/ SLM (Motor 20-2201-46)	20-2201-46-KIT
Resistor/Capacitor (60 Hz)	12-8063-17
Resistor/Capacitor (50 Hz)	12-8063-18
Self Locking Mechanism (SLM)	12-8063-44
14.0 N•m Motor w/ SLM (Motor 20-2201-43)	20-2201-43-KIT
Resistor/Capacitor (60 Hz)	12-8063-35
Resistor/Capacitor (50 Hz)	12-8063-36
Self Locking Mechanism (SLM)	12-8063-44

Customer Kit / Part	Part No.
Handswitch (Option 3) (Handswitch 20-3310-15)	12-8063-19
Handswitch (Option 9) (Handswitch 20-3310-16)	12-8063-20
Limit Switch	12-8063-55
Digital Control Module (DCM)	12-8062-28
Fuse, 7A, 125V (for use on DCM)	11-1372-26
Fuse (F1) w/ 240V option, 0.6A, 250V	11-1370-14
Control End (Option 3) (23-2501-05)	12-8063-25
Control End (Option 9) (23-2500-55)	12-8063-05
Switch Assembly, CPS-4 (20-3200-21)	12-8063-06
PC Board, CPS-4	12-8063-07
Coupling, Control End	12-8063-08
Gasket Kit (Model 29-10_)	12-8063-09
Gasket Kit (Model 29-25_)	12-8063-29
Gasket Kit (Model 29-60_)	12-8063-49

HOW TO ORDER SPARE PARTS

Customer replacement kits may be purchased for spare parts. Contact your Beck Sales Engineer for recommended replacement parts particular to your application. Parts may be ordered by mail, telephone, fax or e-mail, with the confirming order sent to the factory (see inside back cover).

SERVICES

PRODUCT DEMONSTRATIONS

Each of Beck's Sales Engineers has access to a complete set of actuator models so that he can demonstrate virtually any of their features at your location. In order to arrange to see a Beck actuator in your plant or office, contact Beck's Sales Department.

SITE SURVEYS

Beck Sales Engineers are available to discuss your process control requirements. Often a visit to your location is the best way to gain a thorough understanding of your needs, in order to meet them most accurately and completely.

Mounting hardware, torque requirements, linkage, control signal information, and optional equipment can be analyzed most effectively at the work site. Beck's analysis at the job site can help ensure that specifications are accurate, especially in the case of complex applications.

APPLICATION REVIEWS

By sharing your needs with a Beck Sales Engineer you can take advantage of the best application advice for the type of control you

need. This review will yield a better understanding of the versatility of Beck actuators for your installations, as well as complete details on options and accessories to make the process as effective as possible.

SPECIFICATION WRITING

Beck provides specification writing assistance in order to help you specify and order the right actuators for your applications. Beck Sales Engineers will work with you to make it easier for you to obtain the proper equipment and give you confidence that no details are overlooked.

HOW TO OBTAIN SERVICE

Factory repair of actuators or subassemblies is available for both normal and emergency service. To assure prompt processing, contact the factory to receive a Returned Material Authorization (RMA) number. If a repair estimation is desired, please send the name and phone number of your contact for service authorization. It is helpful to include a description of the work desired with the shipment or, in the event of a problem, the malfunction being experienced.

THREE YEAR LIMITED EQUIPMENT WARRANTY

Beck warrants to Buyer that: (i) for a period of 3 years from the date of shipment, the Equipment manufactured by Beck shall materially conform to Beck's published standard specifications in effect as of the date of shipment; and (ii) the Beck Equipment will be free from defects in materials and workmanship. This warranty does not apply to normal wear and tear, or where Beck Equipment failure is a result of improper installation, improper storage, misuse or improper maintenance, or water ingress related to Buyer or its agents failing to apply the stated torque requirements to fasteners when attaching covers or failing to replace temporary conduit plugs as stated in the installation instructions, or entry through conduits.

During the Limited Warranty Period, Buyer shall notify Beck of any alleged warranty claim within 30 days from the date Buyer discovers, or upon reasonable inspection should have discovered, such alleged claim (but in any event prior to the end of the Limited Warranty Period), and Buyer shall return the Beck Equipment in question, at Buyer's expense, to Beck for evaluation, in compliance with the terms stated in the "Return of Equipment" article in the Sales Contract. If Beck determines that the Beck Equipment fails to conform to the limited warranty, then, at Beck's sole discretion and its expense (subject to Buyer's conformity with the warranty), Beck will either: (i) repair or replace the Beck Equipment, without charge, at Beck's factory, or (ii) refund the purchase price of such Beck Equipment, less any applicable discounts, rebates, or credits. In no event will Beck's liability exceed the contract price actually paid for such Beck Equipment subject to a warranty claim. Beck makes no warranty, express or implied, with respect to any Buyout Item. This limited warranty is not transferable or assignable to any transferees of the Beck Equipment.

THIS WARRANTY IS EXPRESSLY IN LIEU OF ANY OTHER EXPRESS OR IMPLIED WARRANTY, INCLUDING IMPLIED WARRANTIES OF MERCHANTABILITY AND FITNESS FOR A PARTICULAR PURPOSE, AND ALL OTHER OBLIGATIONS OR LIABILITIES OF BECK. BUYER ACKNOWLEDGES THAT: (i) BECK HAS MADE NO INDEPENDENT INVESTIGATION OF THE SUITABILITY OF THE EQUIPMENT FOR BUYER'S INTENDED USE OR EXISTING SYSTEMS; AND (ii) BUYER HAS NOT RELIED UPON ANY REPRESENTATION OR WARRANTY MADE BY BECK OR ANY OTHER PERSON ON BECK'S BEHALF, EXCEPT AS SPECIFICALLY PROVIDED IN THE SALES CONTRACT. THIS SECTION SETS FORTH BUYER'S SOLE AND EXCLUSIVE REMEDY FOR ANY BREACH OF THE LIMITED WARRANTY SET FORTH IN THIS SECTION.

A 100% EMPLOYEE OWNED COMPANY

BECK

- founded 1936 -

SINCE 2021



HAROLD BECK & SONS, INC.

11 TERRY DRIVE • NEWTOWN, PENNSYLVANIA 18940 • USA

PHONE: 215-968-4600 • FAX: 215-860-6383 • E-MAIL: sales@haroldbeck.com

www.haroldbeck.com

Made in USA

