

80-2900-04
Rev. 01.1
SUPPLEMENT TO MANUAL:
• 80-2900-03 (Group 29)



GROUP 29 FOUNDATION FIELDBUS SUPPLEMENT

The instructions and procedures for the Installation, Operation, Calibration and Maintenance of Beck Group 29 Actuators are the same as listed in the above manual, except for the differences pertaining to the Foundation Fieldbus interface which are detailed herein.



DCM-2 Features / Configuration

DCM-2 FOR FOUNDATION FIELDBUS (P/N 22-5012-29)

The Foundation Fieldbus version of the DCM-2 includes a fieldbus-powered interface to permit fieldbus access to the DCM-2 operational parameters.

Foundation Fieldbus compatible DCM-2's must be connected to a Foundation Fieldbus compatible control system. All configuration, setup and diagnostics must be done through the fieldbus interface. The Foundation Fieldbus DCM-2 does not have a local configuration interface or the associated status LED's.

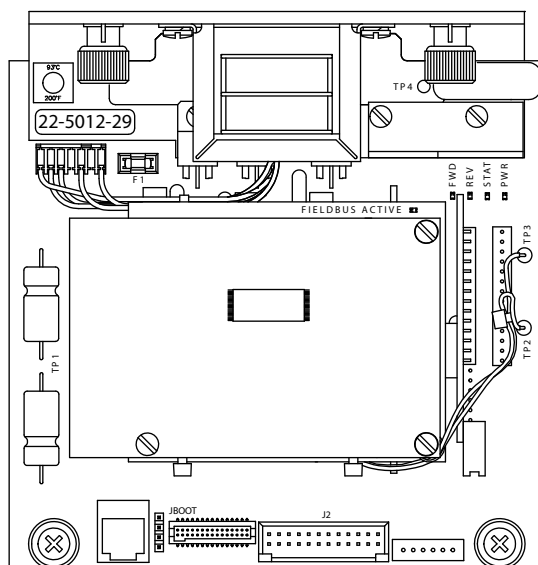

DCM-2 W/ FOUNDATION FIELDBUS

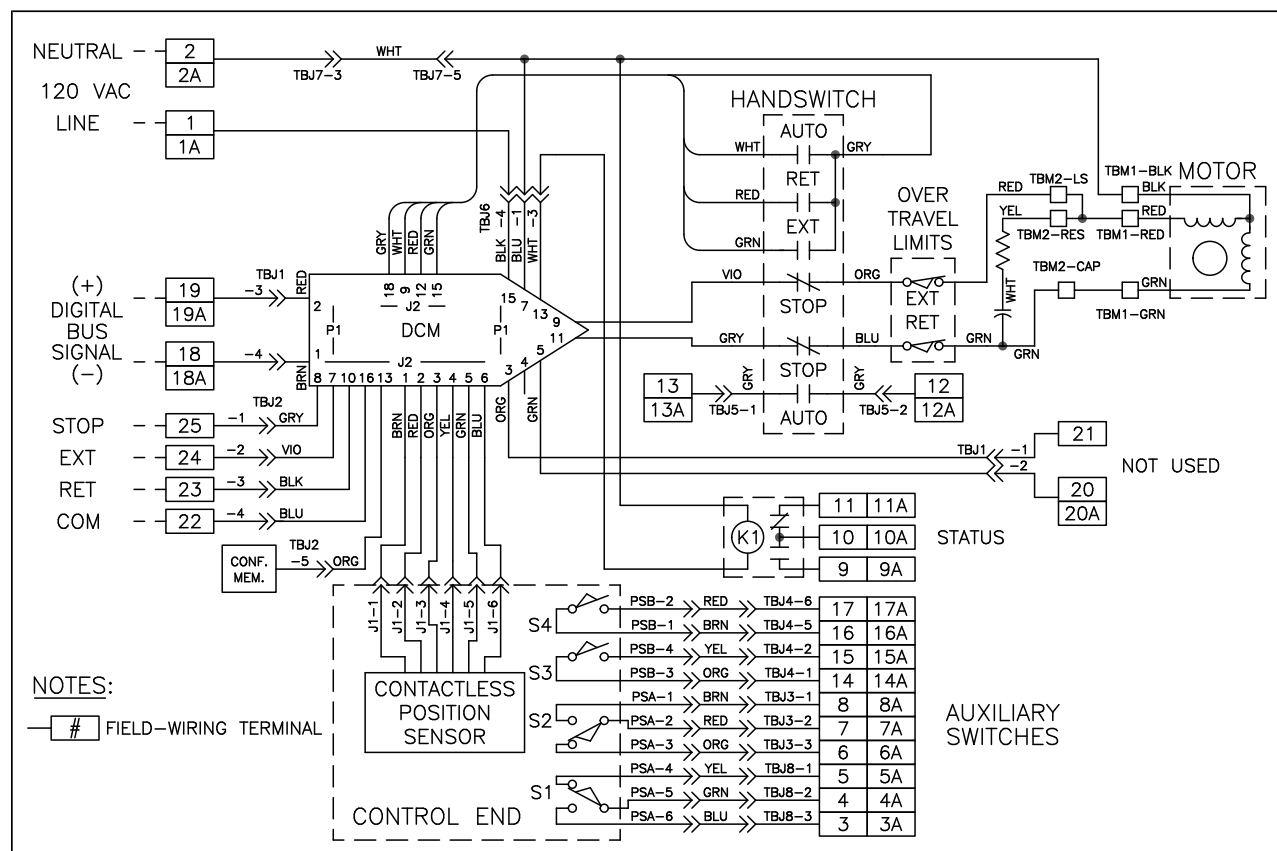

TYPICAL WIRING DIAGRAM

FOUNDATION FIELDBUS COMMUNICATION OVERVIEW

The Fieldbus Foundation defines a large list of predefined blocks and the methods for using them. The Beck DCM-2 includes five blocks: One Resource Block, one Transducer Block and three function blocks.

1. Resource Block

This block is a fieldbus requirement, and is not directly used to control the Beck actuator. This block is a standard block as defined by Fieldbus Foundation, and resembles all other standard Resource Blocks.

For typical automatic operation, this block must be in Auto mode.

2. Transducer Block

This block is a fieldbus requirement, and is generally not directly used in controlling the Beck actuator. The Transducer Block is used to read and write actuator-specific calibration, configuration, and status information. Calibration and configuration information will have a significant effect on the operation of the actuator. For example, the actuator stroke direction corresponding to an increasing set point is determined by a setting in this block.

When installing the actuator pay particular attention to Drive Dir to configure the direction of actuator movement in response to an increasing actuator set point.

For typical automatic operation, this block must be in Auto mode, and the Op Mode parameter (DRIVE_OPERATING_MODE) set to Hold.

3. Analog Output (designated Channel 1)

This is a standard Analog Output function block as defined by Fieldbus Foundation, and it is used to control the Beck actuator. Because it is a standard Analog Output block, it resembles all other standard Analog Output blocks.

Apply the actuator set point (positioning Demand) to CAS_IN. The actuator set point is typically scaled in "percent". This set point is propagated to Transducer Block variable "Demand" (DEMAND_VALUE).

For typical modulating automatic operation, set Channel to 1, set SHED_OPT to NormalShed_NormalReturn, and set the mode to Cas|Auto.

4. Analog Input (designated Channel 2)

This is a standard Analog Input function block as defined by Fieldbus Foundation, and is used in this Beck application to input the thrust load on the actuator's output shaft into the Fieldbus network.

The measurement units are percent. Calibration of the thrust sensor is established by the Transducer Block.

For typical operation, set Channel to 2, and set L_TYPE to Indirect.

5. Analog Input (designated Channel 3)

This is a standard Analog Input function block as defined by Fieldbus Foundation, and is used to import the internal temperature, as measured by the actuator's temperature sensor, into the Fieldbus network.

Minimum and maximum recorded temperatures can be viewed in the Transducer Block. For typical operation, set Channel to 3, and set L_TYPE to Indirect.

CHANGING PARAMETER VALUES

Foundation Fieldbus distinguishes between parameters that are read-write and parameters that are read-only. There is also a technique of writing parameters as a command action. The command actions write values but do not read values. The Beck DD uses these three parameter classifications.

Parameters that are read-only cannot be written at any time. If the fieldbus access tools provide for automatic updating of values, the values should update without manual intervention. The Beck DCM-2 always provides up-to-date parameter information.

Parameters that are read-write can be changed by the technician, but changes have restrictions.

Some fieldbus access tools may apply restrictions based on user names or passwords. The Beck DCM-2 does not implement restrictions of this sort.

Foundation Fieldbus allows most changes to be blocked unless the mode of the block is set to OOS (Out of Service). The Beck DD uses this OOS requirement to protect the system from changes during loop operation. Therefore, parameter writes are blocked unless the mode is set to OOS.

FOUNDATION FIELDBUS *Device Parameters*

COMMONLY USED ACTUATOR SETTINGS & VALUES AVAILABLE THROUGH THE FOUNDATION FIELDBUS TRANSDUCER BLOCK

ACTUATOR SETTINGS & VALUES	TRANSDUCER BLOCK PARAMETER
RESTORE FACTORY CONFIGURATION	Reset Settings & Select Recall Factory Settings
SET THE ACTUATOR MINIMUM STEP SIZE	StepSize
TEMPERATURE SENSING INFORMATION	
Present temperature	Ambient Temp
Temperature extremes	High and Low under Ambient Extreme
Select unit of measure	Temp Unit
STOP/LIMIT ALARMING	
Observe status of the alarm	DCM BIST
Change alarm behavior	LimitSwitch
STALL PROTECTION SETTINGS	
Enable or disable stall protection	StallProtect
Select stall time setting	Stall Time
Read number of stalls logged	Stalls
Reset actuator that is in a "stall" condition	Reset Stall
THRUST SENSING SETTINGS	
Enable or disable the thrust setting feature	Trq/Thr
Read present thrust value	Trq/Thr %
Enter 0% thrust	Trq/Thr Null
Enter span value	Trq/Thr Const
THRUST ALARM SETTINGS	
Set alarm threshold in % of span	Trq/Thr AlarmLevel
Set protection threshold in % of span	Trq/Thr Sht Dn Level
Enable or disable thrust protection	Trq/Thr Protect
THRUST STATISTICS INFORMATION	
Read peak thrust history	Peak Trq/Thr
Read thrust profile vs. position history	CW Trq/Thr or CCW Trq/Thr
ALARM (RELAY) OUTPUT HISTORY CONFIGURATION SETTINGS	
Set alarm polarity (i.e., energize or de-energize on alarm)	Polarity
Select the alarms annunciated at terminal "E"	Mask 1 and Mask 2
DEMAND VS. POSITION CHARACTERIZATION MODE SELECTION	Demand Curve
DEMAND OPERATING MODE (can be set to): "Hold" (correct mode for modulating control with Foundation Fieldbus) "RunCW" (diagnostic mode - should only be used for testing) "RunCCW" (diagnostic mode - should only be used for testing) "Stop" (removes power from the motor)	Op Mode
SETTING A CUSTOM DEMAND CHARACTERIZATION CURVE	DemNode 1 through DemNode 21
OUTPUT SHAFT POSITION SENSING	
Confirm DCM-2 is set for correct Maximum Travel	MaxTravel
Confirm DCM-2 expects CPS-2 signal to increase as shaft rotates CW	Snsr Dir
Confirm correct signal ranges	CPS RngLwr and CPS RngUpr
TRAVEL OF ACTUATOR SHAFT PER 100% DEMAND SETTING	Travel
SET OUTPUT SHAFT 0% POSITION	CPS Zero %
SET DIRECTION OF OUTPUT SHAFT ROTATION FOR INCREASING DEMAND (EXT. VS. RET.)	Drive Dir
OUTPUT SHAFT POSITION FEEDBACK VALUE	Position or PV (in Analog Output Block)

COMPLETE PARAMETER LISTING

Two presentations of the Transducer Block parameters are shown on the following pages. The first listing is in the order the data is listed in the DD. The second listing is an index to allow a person to find a parameter by label, then from that identify the data in the first listing.

In the first listing, the Relative Index column is for reference purposes only, and does not indicate an exact line count or computer index-value.

Parameters that are members of records are shown by the record index followed by the parameter label. Parameters that are not members of records are shown simply as the label name.

In the second listing, the parameters are shown in alphabetical order. The Relative Index-value can be used to find the parameter in the first listing.

CONTROLLING THE ACTUATOR: ANALOG OUT

The Analog Out (AO) function block provides cascade control of the actuator. Because this is a standard Foundation Fieldbus AO function block, the operation of the block is the same as other standard AO blocks.

Two of the AO parameters are particularly important in the Beck application: CAS_IN and PV. CAS_IN is read by the DCM-2 as the Demand signal. PV is read from the DCM-2 as the actual position of the output shaft.

Both the Demand and the actual shaft position are also available in the Transducer Block for reference. Demand is available as Demand % (reference line 15), and the actual output shaft position is available as Position % (reference line 13).

Additionally, the Transducer Block contains other parameters related to the Demand and Position. Some of the parameters modify the actuator performance and some of the parameters give additional details.

One of the most important Transducer Block parameters is the parameter for determining the rotation direction of the output shaft in response to an increasing Demand signal. This parameter is in the Info 2 record, and is called Drive Dir. The formal name is Info 2: Drive Dir.

These related parameters are informational:

Demand Unit
 Position Unit
 Position(deg/in/mm)
 CPS Ranges:CPS Output Unit
 CPS Ranges:CPS Span
 MaxTravel(deg/in/mm)
 Position Limits: PosLwrLim
 Position Limits: PosUpLim
 Position Sense:Pres V
 Position Sense:Unit
 SigDif:DemPosDiff
 SigDif:DemPosDiff Unit
 Unit Select(deg/in/mm)

These parameters change the operation:

Op Mode
 CPS Ranges:CPS Zero%
 CPS Ranges:CPS RngLwr
 CPS Ranges:CPS RngUp
 Demand Source
 Demand Curve
 Info 2:Drive Dir
 Info 2:StepSize
 Info 2:Max Error
 Snsr Dir
 Travel(deg/in/mm)

FOUNDATION FIELDBUS *Transducer Block*

Transducer Block Cross Reference

Transducer Block Index	Record Name (if applicable): Parameter Label	Use
1	ST_REV	fieldbus use, no Beck use
2	TAG_DESC	fieldbus use, no Beck use
3	STRATEGY	fieldbus use, no Beck use
4	ALERT_KEY	fieldbus use, no Beck use
5	MODE_BLK	typically Auto or CASCADE
6	BLOCK_ERR	fieldbus use
7	EVENT_UPDATE	fieldbus use
8	BLOCK_ALM	fieldbus use
9	TRANSDUCER_DIRECTORY	fieldbus use
10	TRANSDUCER_TYPE	fieldbus use
11	XD_ERROR	fieldbus use
12	COLLECTION_DIRECTORY	fieldbus use
13	Position %	present actuator position
14	Position Unit	unit of measure for Position %
15	Demand %	present actuator Demand
16	Demand Unit	unit of measure for Demand %
17	Op Mode	Demand Operating Mode
18	Trq/Thr %	present output shaft Thrust load
19	Trq/Thr Unit	unit of measure for output shaft Thrust
20	Ambient Temp	present DCM-2 temperature
21	Temp Unit	unit of measure for Ambient temperature
22-1	Inhibits: CCW 2 Inhibitor	not used in Group 29
22-2	Inhibits: CCW 1 Inhibitor	reason motor is not rotating output shaft CCW
22-3	Inhibits: CW 2 Inhibitor	not used in Group 29
22-4	Inhibits: CW 1 Inhibitor	Reason motor is not rotating output shaft CW
22-5	Inhibits: LED Status	allows remote checking of which LED's on the DCM-2 are illuminated
22-6	Inhibits: Switch Status	not used in Group 29
23-1	DCM BIST: Operating Status	summary of process-related conditions
23-2	DCM BIST: BIST 1	built-in self-test results
23-3	DCM BIST: BIST 2	built-in self-test results
23-4	DCM BIST: BIST 3	built-in self-test results
23-5	DCM BIST: analog_output_fixed1	not used in Group 29
23-6	DCM BIST: Analog Sig Saturated	analog signals are out of measurement range
24-1	SigDif: DemPosDiff Unit	unit of measure for DemPosDiff
24-2	SigDif: DemPosDiff	the difference between the Demand and the Position
25-1	Statistics: TotalRunTm	total amount of time the motor has been powered
25-2	Statistics: OverTrqs/Thrusts	total number of times the first level of alarm has been reached
25-3	Statistics: Peak Trq/Thr	the highest recorded torque on the output shaft
25-4	Statistics: Reversals	the total number of times the motor has started in the direction opposite to the previous start
25-5	Statistics: Stalls	the total number of times the stall timer has timed out
25-6	Statistics: Starts	the total number of motor starts
25-7	Statistics: LastRun	the duration of the last motor movement
25-8	Statistics: Set up OverTrqs/Thrusts	the number of over-thrusts during the installation period
25-9	Statistics: Set up Peak Trq/Thr	the peak thrust during the installation period
26-1	Ambient Extreme: High	highest temperature recorded in the DCM-2 compartment
26-2	Ambient Extreme: Low	lowest temperature recorded in the DCM-2 compartment

Transducer Block Index	Record Name (if applicable): Parameter Label	Use
27-1	Ambient Rating: Temp Lwr Lim	temperature allowed before alarm asserted
27-2	Ambient Rating: Temp Up Lim	temperature allowed before alarm asserted
28	Position(deg/in/mm)	Position % (Relative Index 13) expressed in engineering units of degrees
29	Unit Select(deg/in/mm)	unit of measure for Position (Relative Index 28)
30-1	Position Sense: Unit	unit of measure for DCM-2 sensing circuit that receives the signal from the CPS-2, always volts
30-2	Position Sense: Pres V	displays the output shaft position voltage signal at the DCM-2 from the CPS-2
31-1	CPS Ranges: CPS Output Unit	unit of measure for CPS-2 output signal to the DCM-2, always volts
31-2	CPS Ranges: CPS Zero%	this is the voltage from the CPS-2 to the DCM-2 that the DCM-2 will interpret as 0% output shaft position
31-3	CPS Ranges: CPS Span	the voltage span from the CPS-2 for the maximum rotation of the output shaft—this is simply the upper range voltage minus the lower range voltage
31-4	CPS Ranges: CPS RngLwr	the CPS-2 voltage signal corresponding to the CCW end of rotation when Travel is set to the maximum rotation
31-5	CPS Ranges: CPS RngUp	the CPS-2 voltage signal corresponding to the CW end of rotation when Travel is set to the maximum rotation
32-1	Position Limits: PosLwrLim	Position Lower Limit, the signal in percent allowed before an alarm is asserted
32-2	Position Limits: PosUpLim	Position Upper Limit, the signal in percent allowed before an alarm is asserted
33	Snsr Dir	the direction of output shaft rotation that causes the CPS-2 signal to increase—should always be CW except in some custom configurations
34	MaxTravel(deg/in/mm)	the maximum output shaft rotation for this model of actuator
35	Travel(deg/in/mm)	amount of output shaft rotation for 100% signal change
36-1	CW Trq/Thr: 1	max torque, output shaft rotating CW, seg 1
36-2	CW Trq/Thr: 2	max torque, output shaft rotating CW, seg 2
36-3	CW Trq/Thr: 3	max torque, output shaft rotating CW, seg 3
36-4	CW Trq/Thr: 4	max torque, output shaft rotating CW, seg 4
36-5	CW Trq/Thr: 5	max torque, output shaft rotating CW, seg 5
36-6	CW Trq/Thr: 6	max torque, output shaft rotating CW, seg 6
36-7	CW Trq/Thr: 7	max torque, output shaft rotating CW, seg 7
36-8	CW Trq/Thr: 8	max torque, output shaft rotating CW, seg 8
36-9	CW Trq/Thr: 9	max torque, output shaft rotating CW, seg 9
36-10	CW Trq/Thr: 10	max torque, output shaft rotating CW, seg 10
37-1	CW Trq/Thr Pos: 1	position in seg 1 where max torque was measured
37-2	CW Trq/Thr Pos: 2	position in seg 2 where max torque was measured
37-3	CW Trq/Thr Pos: 3	position in seg 3 where max torque was measured
37-4	CW Trq/Thr Pos: 4	position in seg 4 where max torque was measured
37-5	CW Trq/Thr Pos: 5	position in seg 5 where max torque was measured
37-6	CW Trq/Thr Pos: 6	position in seg 6 where max torque was measured
37-7	CW Trq/Thr Pos: 7	position in seg 7 where max torque was measured
37-8	CW Trq/Thr Pos: 8	position in seg 8 where max torque was measured
37-9	CW Trq/Thr Pos: 9	position in seg 9 where max torque was measured
37-10	CW Trq/Thr Pos: 10	position in seg 10 where max torque was measured
38-1	CCW Trq/Thr: 1	max torque, output shaft rotating CCW, seg 1
38-2	CCW Trq/Thr: 2	max torque, output shaft rotating CCW, seg 2

FOUNDATION FIELDBUS *Transducer Block*

Transducer Block Index	Record Name (if applicable): Parameter Label	Use
38-3	CCW Trq/Thr: 3	max torque, output shaft rotating CCW, seg 3
38-4	CCW Trq/Thr: 4	max torque, output shaft rotating CCW, seg 4
38-5	CCW Trq/Thr: 5	max torque, output shaft rotating CCW, seg 5
38-6	CCW Trq/Thr: 6	max torque, output shaft rotating CCW, seg 6
38-7	CCW Trq/Thr: 7	max torque, output shaft rotating CCW, seg 7
38-8	CCW Trq/Thr: 8	max torque, output shaft rotating CCW, seg 8
38-9	CCW Trq/Thr: 9	max torque, output shaft rotating CCW, seg 9
38-10	CCW Trq/Thr: 10	max torque, output shaft rotating CCW, seg 10
39-1	CCW Trq/Thr Pos: 1	position in seg 1 where max torque was measured
39-2	CCW Trq/Thr Pos: 2	position in seg 2 where max torque was measured
39-3	CCW Trq/Thr Pos: 3	position in seg 3 where max torque was measured
39-4	CCW Trq/Thr Pos: 4	position in seg 4 where max torque was measured
39-5	CCW Trq/Thr Pos: 5	position in seg 5 where max torque was measured
39-6	CCW Trq/Thr Pos: 6	position in seg 6 where max torque was measured
39-7	CCW Trq/Thr Pos: 7	position in seg 7 where max torque was measured
39-8	CCW Trq/Thr Pos: 8	position in seg 8 where max torque was measured
39-9	CCW Trq/Thr Pos: 9	position in seg 9 where max torque was measured
39-10	CCW Trq/Thr Pos: 10	position in seg 10 where max torque was measured
40	Trq/Thr	whether the thrust sensing function is enabled
41	Trq/Thr AlarmLevel	the output shaft thrust that is interpreted as an over-thrust
42	Trq/Thr Shut Dn Level	the output shaft thrust that is interpreted as a severe over-thrust
43	Trq/Thr Sensor Unit	unit of measure for thrust alarm levels, always percent
44-1	Trq/Thr Range: Trq/Thr Null	the internal DCM-2 signal associated with 0% output shaft thrust
44-2	Trq/Thr Range: Trq/Thr Const	the internal DCM-2 signal span associated with the output shaft thrust
45	Trq/Thr Cal Unit	a custom unit defined for the DCM-2 internal thrust signal
46	Drive S/N	the serial number as shown on the actuator nameplate
47	Model#	a field that is created within the DCM-2 by examining Drive S/N—if this does not match the model of the actuator, change Drive S/N
48	Type	a broad classification of DCM-2 type based on Drive S/N
49-1	Info 1: Shaft Dir	not used on Group 29
49-2	Info 1: Geometry	classification of output shaft movement: linear or rotary
49-3	Info 1: Embed Mem	not used on Group 29
49-4	Info 1: groupNumber	Beck Group number based on Drive S/N
49-5	Info 1: HandSwType	identifies whether Handswitch is a full power bypass of the DCM-2 or a low voltage input to the DCM-2
49-6	Info 1: LimSwType	identifies whether the over-travel limit switches act to block motor power or are low voltage inputs to the DCM-2
49-7	Info 1: modelNumber	model number based on Drive S/N
49-8	Info 1: Gear Ratio	not used on Group 29
49-9	Info 1: Gear Units	not used on Group 29
49-10	Info 1: Motor Poles	not used on Group 29
49-11	Info 1: Pole Units	not used on Group 29
49-12	Info 1: OutRating	not used on Group 29
49-13	Info 1: Output Units	not used on Group 29
49-14	Info 1: StrainGage	not used on Group 29
49-15	Info 1: StrainUnits	not used on Group 29

Transducer Block Index	Record Name (if applicable): Parameter Label	Use
49-16	Info 1: ScrewTrav	not used on Group 29
49-17	Info 1: ScrewTravUnits	not used on Group 29
50-1	Info 2: LocalCntrl	not used on Group 29 for Foundation Fieldbus
50-2	Info 2: LOS Mode	not used on Group 29 for Foundation Fieldbus
50-3	Info 2: LOS Pos	not used on Group 29 for Foundation Fieldbus
50-4	Info 2: LimitSwitch	modifies the behavior of Stop/Limit alarm
50-5	Info 2: Trq/Thr Protect	whether the actuator motor will be turned off on severe overthrust conditions
50-6	Info 2: StepSize	the typical smallest Demand change that will cause an output shaft movement
50-7	Info 2: Max Error	if the Demand signal doesn't change and a technician moves the Handwheel back and forth, this is the theoretical maximum movement translated to the output shaft
50-8	Info 2: Drive Dir	the direction the output shaft moves in response to an increasing Demand signal
50-9	Info 2: Stall Time	the amount of time the motor will run before Stall Protection
50-10	Info 2: Handswitch	the Handswitch is always enabled
51	StallProtect	whether actuator motor will be turned off if the Stall Time counter expires
52-1	Info 3: Flag Status	a copy of some data from the DCM BIST parameters
52-2	Info 3: Operating Status Alt	a copy of some data from the DCM BIST parameters
52-3	Info 3: Present Freq	not used on Group 29
52-4	Info 3: DC Volts	not used on Group 29
52-5	Info 3: Line Freq	the power line frequency as measured by the DCM-2
53	Power	the Group 29 is designed for 1-phase power
54	Max Freq	not used on Group 29
55	MaxTravelTm	not used on Group 29
56	Feedback	with fieldbus, only used for special retrofit applications
57-1	Alarm Contact: Polarity	whether the solid state relay opens on alarm or closes on alarm
57-2	Alarm Contact: Mask 1	which alarms cause the solid state relay to change state
57-3	Alarm Contact: Mask 2	which alarms cause the solid state relay to change state.
58	Demand Source	in Group 29 fieldbus applications, should read HART/FF
59	Demand Curve	whether Demand is interpreted as linear or a curve
60-1	DemNode1: DemNode1X	allows setting the Demand characterization node
60-2	DemNode1: DemNode1Y	allows setting the Demand characterization node
61-1	DemNode2: DemNode2X	allows setting the Demand characterization node
61-2	DemNode2: DemNode2Y	allows setting the Demand characterization node
62-1	DemNode3: DemNode3X	allows setting the Demand characterization node
62-2	DemNode3: DemNode3Y	allows setting the Demand characterization node
63-1	DemNode4: DemNode4X	allows setting the Demand characterization node
63-2	DemNode4: DemNode4Y	allows setting the Demand characterization node
64-1	DemNode5: DemNode5X	allows setting the Demand characterization node
64-2	DemNode5: DemNode5Y	allows setting the Demand characterization node
65-1	DemNode6: DemNode6X	allows setting the Demand characterization node
65-2	DemNode6: DemNode6Y	allows setting the Demand characterization node
66-1	DemNode7: DemNode7X	allows setting the Demand characterization node
66-2	DemNode7: DemNode7Y	allows setting the Demand characterization node
67-1	DemNode8: DemNode8X	allows setting the Demand characterization node
67-2	DemNode8: DemNode8Y	allows setting the Demand characterization node

FOUNDATION FIELDBUS *Transducer Block*

Transducer Block Index	Record Name (if applicable): Parameter Label	Use
68-1	DemNode9: DemNode9X	allows setting the Demand characterization node
68-2	DemNode9: DemNode9Y	allows setting the Demand characterization node
69-1	DemNode10: DemNode10X	allows setting the Demand characterization node
69-2	DemNode10: DemNode10Y	allows setting the Demand characterization node
70-1	DemNode11: DemNode11X	allows setting the Demand characterization node
70-2	DemNode11: DemNode11Y	allows setting the Demand characterization node
71-1	DemNode12: DemNode12X	allows setting the Demand characterization node
71-2	DemNode12: DemNode12Y	allows setting the Demand characterization node
72-1	DemNode13: DemNode13X	allows setting the Demand characterization node
72-2	DemNode13: DemNode13Y	allows setting the Demand characterization node
73-1	DemNode14: DemNode14X	allows setting the Demand characterization node
73-2	DemNode14: DemNode14Y	allows setting the Demand characterization node
74-1	DemNode15: DemNode15X	allows setting the Demand characterization node
74-2	DemNode15: DemNode15Y	allows setting the Demand characterization node
75-1	DemNode16: DemNode16X	allows setting the Demand characterization node
75-2	DemNode16: DemNode16Y	allows setting the Demand characterization node
76-1	DemNode17: DemNode17X	allows setting the Demand characterization node
76-2	DemNode17: DemNode17Y	allows setting the Demand characterization node
77-1	DemNode18: DemNode18X	allows setting the Demand characterization node
77-2	DemNode18: DemNode18Y	allows setting the Demand characterization node
78-1	DemNode19: DemNode19X	allows setting the Demand characterization node
78-2	DemNode19: DemNode19Y	allows setting the Demand characterization node
79-1	DemNode20: DemNode20X	allows setting the Demand characterization node
79-2	DemNode20: DemNode20Y	allows setting the Demand characterization node
80-1	DemNode21: DemNode21X	allows setting the Demand characterization node
80-2	DemNode21: DemNode21Y	allows setting the Demand characterization node
81	Device Status	a copy of some data from the DCM BIST parameters
82-1	Misc Status: analog_output_fixed2	not used on Group 29 for Foundation Fieldbus
82-2	Misc Status: analog_output_fixed3	not used on Group 29 for Foundation Fieldbus
82-3	Misc Status: analog_output_saturated2	not used on Group 29 for Foundation Fieldbus
82-4	Misc Status: analog_output_saturated3	not used on Group 29 for Foundation Fieldbus
82-5	Misc Status: xmtr_specific_status_4	not used on Group 29 for Foundation Fieldbus
82-6	Misc Status: xmtr_specific_status_5	not used on Group 29 for Foundation Fieldbus
83-1	Installed Features: Pot Supply	not used on Group 29 for Foundation Fieldbus
83-2	Installed Features: FB Out	not used on Group 29 for Foundation Fieldbus
83-3	Installed Features: Trq/Thr Snr	not used on Group 29 for Foundation Fieldbus
84	Board Mfd	a reference manufacture date entered by Beck, has no affect on actuator operation
85	Calbrtd	the calibration date has no affect on actuator operation
86	Setup	the setup date has no affect on actuator operation
87-1	RT Clock: Day	real time clock, day of month, has no affect on actuator operation
87-2	RT Clock: Month	real time clock, month, has no affect on actuator operation
87-3	RT Clock: Year	real time clock, year, has no affect on actuator operation
87-4	RT Clock: Hour (24)	real time clock, hour (24 hour format), has no affect on actuator operation
87-5	RT Clock: Minute	real time clock, minute, has no affect on actuator operation

Transducer Block Index	Record Name (if applicable): Parameter Label	Use
87-6	RT Clock: Second	real time clock, second, has no affect on actuator operation
87-7	RT Clock: rtc_status	not used on Group 29 for Foundation Fieldbus
88-1	Beck Software Info: DCM Software Rev	number used by Beck for version tracking purposes
88-2	Beck Software Info: Checksum	number used by Beck for version tracking purposes
89	Device ID	number used by Beck for DCM-2 tracking purposes
90	Status	a text message sent from the DCM-2 to summarize DCM-2 status
91	Reset Settings	reset the DCM-2 microcomputer
92	Write Protect	allows or prevents changes to the DCM-2 configuration
93	Reset Changed Flag	resets the “configuration changed” flag in Device Status, has no effect on actuator performance
94	Perform Test	instructs the DCM-2 to check various power and sensing circuits—this test should not be run unless sudden output shaft movements are allowable
95	Reset	this reset simulates switching the power off and back on
96	Identify	causes an LED on the DCM-2 to flash to indicate the DCM-2 has received the command
97	Reset Stall	a method for resetting the Stall alarm

RESETTING THE DCM-2

There are three methods which may be used to reset the DCM-2:

1. **Recall Factory Settings.** Returns the DCM-2 to the configuration as shipped from the factory.
2. **Use Model Defaults.** Updates the DCM-2 configuration based on the actuator model number.
3. **Reset Board.** Simulates the effect of switching the power off and back on.

FOUNDATION FIELDBUS *Transducer Block*

Transducer Block Cross Reference

Label	Transducer Block Index
ALERT_KEY	4
Ambient Temp	20
Analog Sig Saturated	23-6
analog_output_fixed1	23-5
analog_output_fixed2	82-1
analog_output_fixed3	82-2
analog_output_saturated2	82-3
analog_output_saturated3	82-4
BIST 1	23-2
BIST 2	23-3
BIST 3	23-4
BLOCK_ALM	8
BLOCK_ERR	6
Board Mfd	84
Calbrtd	85
CCW 1 Inhibitor	22-2
CCW 2 Inhibitor	22-1
CCW Trq/Thr	38-1
CCW Trq/Thr Pos	39-1
Checksum	88-2
COLLECTION_DIRECTORY	12
CPS Output Unit	31-1
CPS RngLwr	31-4
CPS RngUpr	31-5
CPS Span	31-3
CPS Zero%	31-2
CW 1 Inhibitor	22-4
CW 2 Inhibitor	22-3
CW Trq/Thr	36-1
CW Trq/Thr Pos	37-1
Day	87-1
DC Volts	52-4
DCM Software Rev	88-1
Demand %	15
Demand Curve	59
Demand Source	58
Demand Unit	16
DemNode10X	69-1
DemNode10Y	69-2
DemNode11X	70-1
DemNode11Y	70-2
DemNode12X	71-1
DemNode12Y	71-2
DemNode13X	72-1
DemNode13Y	72-2
DemNode14X	73-1
DemNode14Y	73-2
DemNode15X	74-1
DemNode15Y	74-2

Label	Transducer Block Index
DemNode16X	75-1
DemNode16Y	75-2
DemNode17X	76-1
DemNode17Y	76-2
DemNode18X	77-1
DemNode18Y	77-2
DemNode19X	78-1
DemNode19Y	78-2
DemNode1X	60-1
DemNode1Y	60-2
DemNode20X	79-1
DemNode20Y	79-2
DemNode21X	80-1
DemNode21Y	80-2
DemNode2X	61-1
DemNode2Y	61-2
DemNode3X	62-1
DemNode3Y	62-2
DemNode4X	63-1
DemNode4Y	63-2
DemNode5X	64-1
DemNode5Y	64-2
DemNode6X	65-1
DemNode6Y	65-2
DemNode7X	66-1
DemNode7Y	66-2
DemNode8X	67-1
DemNode8Y	67-2
DemNode9X	68-1
DemNode9Y	68-2
DemPosDiff	24-2
DemPosDiff Unit	24-1
Device ID	89
Device Status	81
Drive Dir	50-8
Drive S/N	46
Embed Mem	49-3
EVENT_UPDATE	7
FB Out	83-2
Feedback	56
Flag Status	52-1
Gear Ratio	49-8
Gear Units	49-9
Geometry	49-2
groupNumber	49-4
Handswitch	50-10
HandSwType	49-5
High	26-1
Hour (24)	87-4
Identify	96

Label	Transducer Block Index
LastRun	25-7
LED Status	22-5
LimitSwitch	50-4
LimSwType	49-6
Line Freq	52-5
LocalCntrl	50-1
LOS Mode	50-2
LOS Pos	50-3
Low	26-2
Mask 1	57-2
Mask 2	57-3
Max Error	50-7
Max Freq	54
MaxTravel(deg/in/mm)	34
MaxTravelTm:	55
Minute	87-5
MODE_BLK	5
Model#	47
modelName	49-7
Month	87-2
Motor Poles	49-10
Op Mode	17
Operating Status	23-1
Operating Status Alt	52-2
Output Units	49-13
OutRating	49-12
OverTrqs/Thrusts	25-2
Peak Trq/Thr	25-3
Perform Test	94
Polarity	57-1
Pole Units	49-11
Position %	13
Position Unit	14
Position(deg/in/mm)	28
PosLwrLim	32-1
PosUprLim	32-2
Pot Supply	83-1
Power	53
Pres V	30-2
Present Freq	52-3
Reset	95
Reset Changed Flag	93
Reset Settings	91
Reset Stall	97
Reversals	25-4
rtc_status	87-7
ScrewTrav	49-16
ScrewTravUnits	49-17
Second	87-6
Set up OverTrqs/Thrusts	25-8

Label	Transducer Block Index
Set up Peak Trq/Thr	25-9
Setup	86
Shaft Dir	49-1
Snsr Dir	33
ST_REV	1
Stall Time	50-9
StallProtect	51
Stalls	25-5
Starts	25-6
Status	90
StepSize	50-6
StrainGage	49-14
StrainUnits	49-15
STRATEGY	3
Switch Status	22-6
TAG_DESC	2
Temp Lwr Lim	27-1
Temp Unit	21
Temp Upr Lim	27-2
TotalRunTm	25-1
TRANSDUCER_DIRECTORY	9
TRANSDUCER_TYPE	10
Travel(deg/in/mm)	35
Trq/Thr	40
Trq/Thr %	18
Trq/Thr AlarmLevel	41
Trq/Thr Cal Unit	45
Trq/Thr Const	44-2
Trq/Thr Null	44-1
Trq/Thr Protect	50-5
Trq/Thr Sensor Unit	43
Trq/Thr Shut Dn Level	42
Trq/Thr Snsr	83-3
Trq/Thr Unit	19
Type	48
Unit	30-1
Unit Select(deg/in/mm)	29
Write Protect	92
XD_ERROR	11
xmtr_specific_status_4	82-5
xmtr_specific_status_5	82-6
Year	87-3

TROUBLESHOOTING *Electronics*

TROUBLESHOOTING USING FF

In automatic control, the actuator should run the motor to position the output shaft in relation to the Demand signal. If the output shaft does not reach the desired location, there are three questions to answer:

1. Check the Demand signal. Is the DCM-2 receiving the correct Demand signal?
2. Check the shaft position. Does the DCM-2 think the output shaft position matches the Demand signal?
3. If the position doesn't match the Demand, why doesn't the DCM-2 run the motor?

FIRST CHECKS

The Foundation Fieldbus version of the DCM-2 includes a fieldbus-powered interface to permit fieldbus access to the DCM-2 operational parameters. Whenever fieldbus signaling voltage is available on the fieldbus, this interface will respond to fieldbus communication, but access to the DCM-2 parameters requires that 120V ac (or 240V ac, if appropriate) is available at the actuator power terminals.

All configuration and diagnostic settings are controlled by the fieldbus network. Therefore, the Foundation Fieldbus DCM-2 does not have a local configuration interface or the associated status LED's. It does have the standard Overview LED's and the RS-232 connector (J20) (see Instruction Manual 80-2900-03 for details).

If the fieldbus connections are correct and the AC power connections are absent, the actuator will appear on the network, but the fieldbus function blocks will not update properly and the Transducer Block will not go into Auto. If the AC power connections are correct and the fieldbus connections are absent, the actuator will not operate as expected and will not appear on the network.

If the fieldbus connections are correct and the AC power connection is correct, the actuator should appear on the network, the DCM-2 FIELDBUS ACTIVE LED should blink, and the DCM-2 PWR LED should pulse. If the LED's are not as described, the DCM-2 is not operating properly.

For the DCM-2 to respond properly to the Demand signal, the Resource Block and Transducer Block must both be in Auto mode, and the Analog Output Block must be in Cascade mode. Refer to Foundation Fieldbus Communication Overview (page 3).

CHECKING DEMAND

In Foundation Fieldbus systems, Demand is communicated to the DCM-2 as a percentage value through the CAS_IN input of the Analog Output function block. Using a communicator, the Demand should be readable as the process applied to that signal line. Also, the status of the CAS_IN signal should be Good.

For the CAS_IN signal line to be accepted by the Analog Output function block, the Analog Output Function Block must be in Cascade mode. Make certain the Beck Resource Block and Transducer Block modes are both Auto.

With the proper signal applied to the Analog Output block and the proper modes, the Demand value should be readable in the Transducer Block as Demand %. Also, the OpMode parameter in the Transducer Block should read Hold.

If these conditions are not as described, the DCM-2 is not accepting the correct Demand signal. Refer to Foundation Fieldbus Communication Overview (page 3).

CHECKING SHAFT POSITION

The output shaft position can be read as the PV parameter of the Analog Output Block, and can be read as Position % in the Transducer Block.

Does Position % match Demand %? The exactness of the match is controlled by the parameter Step Size. If they match, the DCM-2 is not running the motor because the signals appear to match.

If the signals match, the next question is whether Position % is correct for the actual output shaft position. Refer to Instruction Manual 80-2900-03. The CPS-2 signal voltage as measured by the DCM-2 is available in the Transducer Block as parameter Position Sense. The actual voltage can be measured with a voltage meter between test points TP4(+) and TP1(-). Refer to Instruction Manual 80-2900-03.

POSITION AND DEMAND MISMATCH

If the shaft position and the Demand do not match and the motor is not running, then some factor is preventing the DCM-2 from running the motor. The fieldbus interface provides extensive information for finding this factor.

The Transducer Block contains two parameters that summarize why the motor is not running: one parameter for CW and one for CCW. The parameter names are CW Inhibitor and CCW Inhibitor. If the parameter is 0 (has no bits set), the motor should run in that direction. If the parameter is not 0, the DCM-2 will not try to run the motor in that direction. The bits that show in the parameter are the reasons the motor is not running in that direction.

INHIBITORS

Label	Cause of Motor Not Running
OverTrq/Thrust	Excessive thrust load on output shaft
Balance	Demand indicates motor should not run this direction
Stall	Stall
Supervisory	The DCM-2 is initializing
Switch Block	Not used on Group 29 actuators
Bad Pos Sig	The Position signal from the CPS-2 is not acceptable
Bad Dem Sig	Not used on fieldbus systems
Local Cal	Not used on fieldbus systems

If the inhibitor parameter is 0 but the motor is not running, power to the motor is being blocked by something over which the DCM-2 microcomputer has no control. Possibility 1 (listed below) should lead to a Stall alarm. The other possibilities should create a Stop/Limit alarm.

1. The motor is stalled, and cannot rotate. This condition is unlikely if the motor operated properly with the Handswitch.
2. The Handswitch or an Over-travel Limit Switch is preventing power from reaching the motor. Make certain the Handswitch is in AUTO. The Handswitch and the DCM-2 both use the same over-travel limits, so if the limits do not prevent Handswitch operation, they should not prevent DCM-2 operation.
3. Ensure the wiring is correct according to the wiring diagram specific to your actuator (attached to the inside of the cover).
4. The output section of the DCM-2 is not delivering power to the motor.
5. The DCM-2 fuse is cleared. This fuse is rated at more than twice the motor current, and the Beck motor has no significant inrush current. Therefore, only in very rare circumstances is the fuse cleared. These circumstances are generally wiring errors during customer installation. For the fuse location, refer to Instruction Manual 80-2900-03.

TROUBLESHOOTING *Electronics*

BUILT-IN SELF-TEST (BIST)

The DCM-2 microcomputer continuously runs diagnostic routines in the background. These routines look for situations that could indicate the DCM-2 is not working reliably. Examples of tests are:

- whether a power failure has occurred
- if the motor should be running, is there motor current?
- does the temperature sensor appear to be functioning properly?

There are many built-in self-test routines. To simplify identifying test results, the tests are separated into the following five categories.

BIST: OPERATING STATUS

The Operating Status parameter is a summary of whether process-related conditions are inside or outside of anticipated limits.

- 9 Position:** caused by the CPS-2 signal being outside the range anticipated by the DCM-2.
- 10 Temperature:** the ambient temperature of the DCM-2 is outside of the rating.
- 11 Torque:** the first alarm level of thrust is being exceeded.
- 12 Over-Torque Stop:** over-thrust protection is preventing the DCM-2 from running the motor.
- 13 Stalled:** a Stall alarm is active.
- 14 Feedback Open:** the Feedback signal is enabled, but cannot flow the proper current.
- 15 Switch Block:** the DCM-2 cannot power the motor due to an electro-mechanical switch. Check the Handswitch and over-travel limit switches.

BIST: BIST 1

Real Time Clock hardware failure

The data in the Real Time Clock appears invalid.

Torque/Thrust sensing error

The DCM-2 circuitry for measuring the Thrust signal does not appear to be functioning properly. Check the Thrust sensing cable.

Position sensing error

The DCM-2 circuitry for measuring the CPS-2 signal does not appear to be functioning properly.

Demand processing error

The Demand signal appears to have a data format error.

FRAM Memory has failed

The continuous built-in self-test cannot verify the memory for statistics information is operating properly.

Position signal in LOS

The DCM-2 is reading a CPS-2 signal that is outside of the range associated with a functional CPS-2.

Temperature A/D Fail

The DCM-2 circuitry for measuring the ambient temperature does not appear to be functioning properly.

Memory failure

The continuous built-in self-test cannot verify the microcomputer is operating properly.

BIST: BIST 2**Local control activity detected**

Not applicable to the fieldbus DCM-2.

Demand Setting is out of limit

The Demand signal appears too high, and probably has a data format error.

Current Overlimit

Not used in Group 29.

Power Source Not Nominal

Not used in Group 29.

BIST: BIST 3**Loop Current Detected while under HART/FF Control**

The microcomputer configuration does not appear valid for Foundation Fieldbus.

BIST: ANALOG SIG SATURATED**Position out of accurate measurement range**

The DCM-2 is reading a CPS-2 signal that is outside of the range for accurate measurements.

Demand out of accurate measurement range

The Demand signal appears too low or too high, and probably has a data format error.

Temperature out of accurate measurement range

The DCM-2 ambient temperature reading is extreme to the point of uncertainty.

Torque/Thrust out of accurate measurement range

The DCM-2 is not able to read a valid signal from the Thrust sensor. Check the Thrust sensing cable.

NOTES



HART
COMMUNICATION PROTOCOL



BECK[®]

HAROLD BECK & SONS, INC.

Made in USA



11 TERRY DRIVE • NEWTOWN, PENNSYLVANIA 18940 • USA
PHONE: 215-968-4600 • FAX: 215-860-6383 • E-MAIL: sales@haroldbeck.com
www.haroldbeck.com