

BECK®

INSTRUCTION MANUAL



INTRODUCTION

Providing up to 30 lb-ft (41 N•m) of torque, the Group 31 actuator is designed for operation with quarter-turn valves (typically up to 4 inches or 102 mm) or small dampers and may be direct coupled or connected by means of a linkage. The Group 31 actuator provides a weatherproof enclosure, and is also available approved for use in hazardous locations. Group 31 actuators may be mounted in any orientation.

The Group 31 actuator is a compact, in-line assembly made up of two main sections: The output section and the control module. The output section consists of the gear train and motor. The control module contains the motor control, feedback signal electronics, switches and wiring terminal board. This module is enclosed and sealed by a bolted cast aluminum cover and gasket (or a threaded aluminum cover and O-ring on hazardous location approved actuators). Customer power and control wires are brought to the terminal board through two 3/4" N.P.T threaded conduit entrances located on the output section.

HAZARDOUS LOCATION ACTUATORS FOR GAS AND DUST AREA CLASSIFICATIONS (OPTIONAL)

Group 31 Actuators are available approved for the following Protection Methods and Protection Concepts, suitable for use in:

CSA (USA/Canada)

Class I, Division 1 & 2, Group D
 Class II, Division 1, Groups E, F & G
 Class II, Division 2, Groups F & G
 Class III, Division 1 & 2
 Type 4; IP66

CE-ATEX (Europe); UKCA (United Kingdom)



CE  II 3 G Ex nC IIA T4
 CE  II 3 D Ex tc IIIC T102°C
 Tamb = -40°C to 65°C; IP66
 per ATEX Directive 94/9/EC

TABLE OF CONTENTS

Product Description	
Outline Dimensions	4
Mounting Options	5
General Specifications	7
Installation	9
Power and Signal Wiring	11
Actuator Mounting	13
Mechanical Stops	13
Installing an Actuator	14
Direct Coupling	14
Linkage Connection	15
Start-up Instructions	17
Calibration	
Switches	18
Changing Direction of Travel	20
Feedback Signal	22
Input Signal	24
Maintenance	
Troubleshooting	28
Level 1 Maintenance	30
Level 2 Maintenance	32
Level 3 Maintenance	35
Recommended Spare Parts	37
Index	38
List of Figures	38
List of Tables	38
Services	39
Warranty	39

PRODUCT DESCRIPTION

OUTLINE DIMENSIONS FOR BASIC ACTUATOR

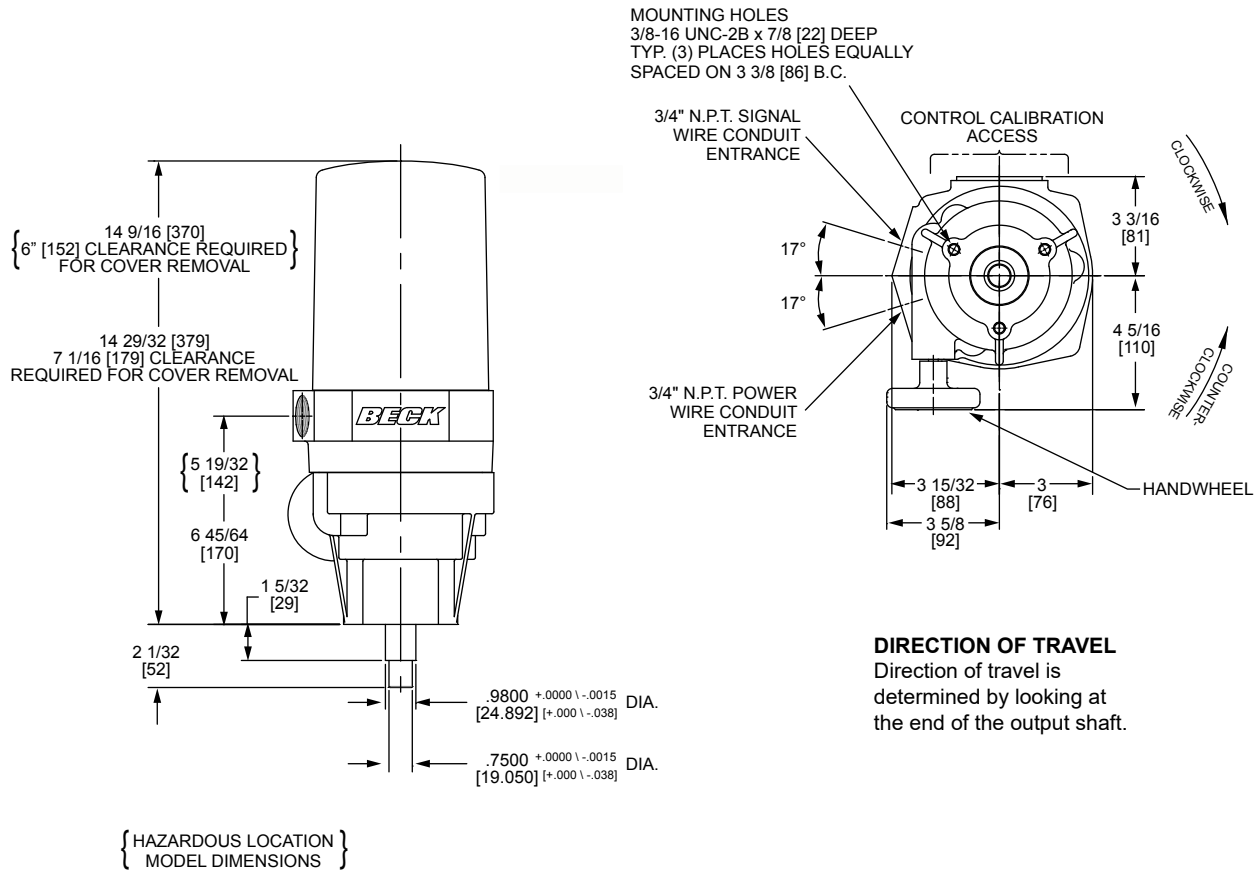

All dimensions are in inches and [mm] unless otherwise specified.
 Threads and tapped holes are specified as Unified Thread sizes only.
 Conduit pipe threads per American National Standard Taper Pipe Threads (N.P.T.).

FACTORY-MOUNTED ASSEMBLIES

Beck can supply Group 31 actuators factory mounted to new valves or dampers and shipped as a unitized package ready for pipeline installation. A Beck designed coupling or linkage assembly connects the actuator to the final control element and permits easy field adjustment with reliable transmission of actuator torque.

The actuator can also be supplied separately with a yoke or bracket designed for your installation.

MOUNTING OPTION A
 YOKE MOUNTING WITH COUPLING CONNECTION
 AND STANDARD MECHANICAL STOP

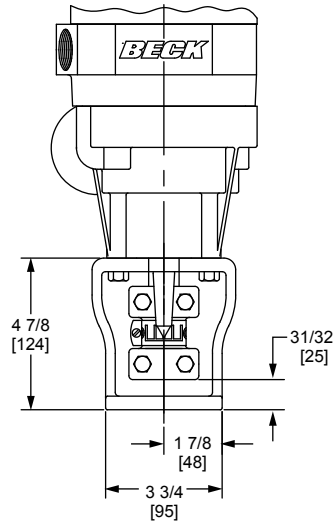

MOUNTING OPTION B
 BRACKET MOUNTING WITH CRANK ARM ASSEMBLY
 AND STANDARD MECHANICAL STOP

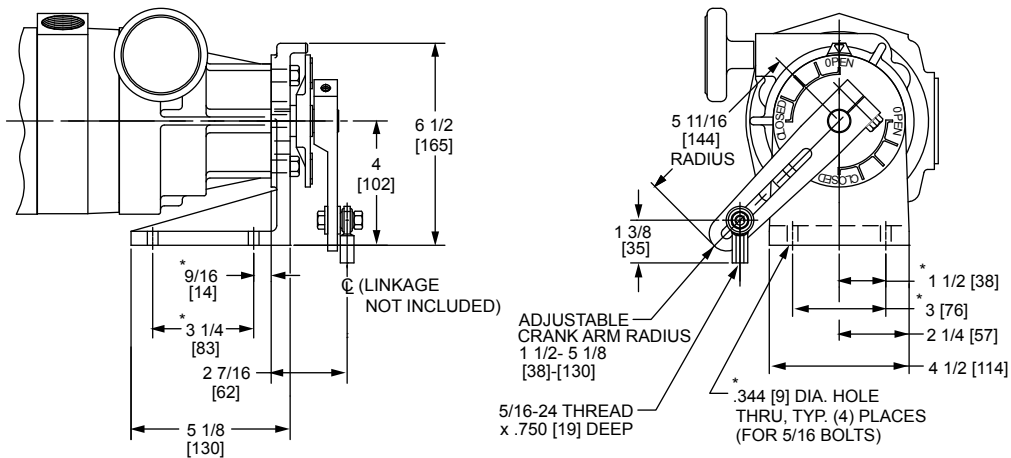

* Standard dimension shown for mounting bracket, .344 dia. hole thru, typ.4 places for 5/16 bolts (consult factory if different bolt hole pattern is needed).

NOTE: All dimensions are in inches and [mm] and are subject to change.

PRODUCT DESCRIPTION

MOUNTING OPTION C BASIC ACTUATOR WITH CRANK ARM ASSEMBLY AND MECHANICAL STOP KIT

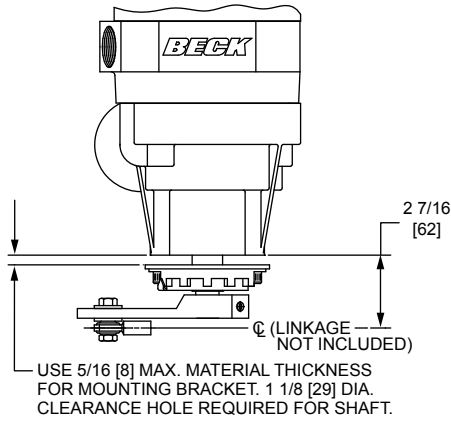

MOUNTING OPTION D BASIC ACTUATOR WITH MECHANICAL STOP KIT

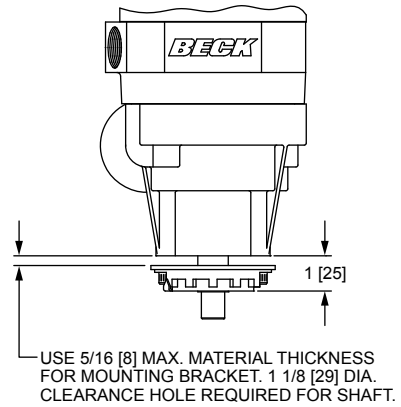

TYPICAL CRANK ARM ASSEMBLY (10-3492-02 SHOWN)

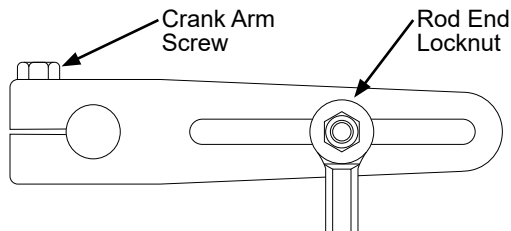

FRONT VIEW

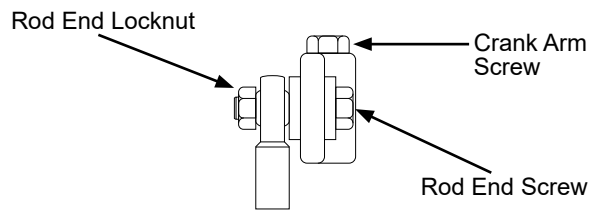

SIDE VIEW

MOUNTING OPTION E YOKE AND BASE MOUNTING WITH COUPLING CONNECTION AND STANDARD MECHANICAL STOP

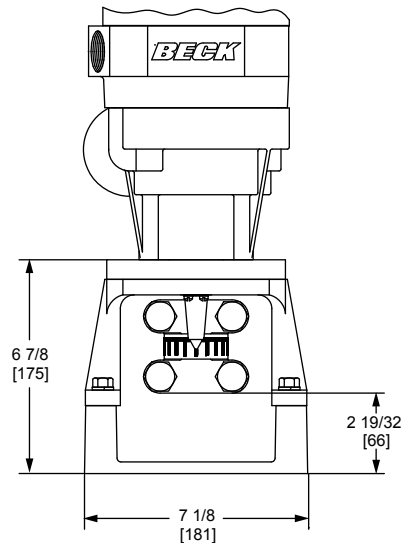

NOTE: All dimensions are in inches and [mm] and are subject to change.

Recommended Screw Torques

Description	Screw Size (in.) / Type	Torque	
		lb-ft	N•m
Crank Arm Screw	5/16-24x1 3/8 L Hex Head (grade 5)	20	27
Rod End Screw	5/16-24x1 3/8 L Hex Head (grade 5)	20*	27*
Rod End Lock Nut	5/16-24 Hex Head (zinc plated)	20*	27*
Coupling Screw	3/8-24x1 1/4 L Hex Head (grade 8)	35	47
Mounting Bracket Screw	3/8-16x1 L Hex Head (zinc plated)	20	27
Stop Collar Clamp Screw	3/8-16x7/8 L Socket Head	22	30

*Apply 90% of specified torque when optional Stainless Steel fasteners are used.

GENERAL SPECIFICATIONS

Input Power	120 V ac single phase, 50 or 60 Hz
Allowable Tolerance	+10% / -15%
Max. Current & Power	0.5A, 60W @ 120 Vac
Output Torque	30 lb-ft (41 N•m) at 24 second timing
Timing Options	60 cycle power: 24 sec/90° 50 cycle power: 22 sec/90° or 29 sec/90°
Operating Temperature	-40°F to 150°F (-40°C to 65°C), 0 to 100% relative humidity, non-condensing
Motor Control	Two types of motor control are available: 1) 120 V ac contact closure -- control options 1 and 2. Motor is energized by 120 V ac line current from a remote controller or manual switches. 2) Milliamp modulating -- control option 3. Consists of feedback potentiometer, feedback signal circuit, error amplifier and two electronic output switches. Differences between the feedback signal and input signal are amplified, activating the electronic output switch necessary to drive the motor in the proper direction to force the signal differential to zero.
Input Signal (Option 3)	4-20 mA or 1-5 V dc
Signal Span Adj.	50 to 125% of 4 V span
Signal Zero Adj.	Up to 120% of Span Split Signal Range: 4-12 mA or 12-20 mA
Deadband	1.0% of Span
Sensitivity	0.2% of Span
Feedback Signal (Options 2 & 3)	4-20 mA or 1-5 V dc
Output Stability for Temperature Change	±0.03%/°C of Span for -40°C to 50°C
Stall Relay Contacts (Option 3)	Form A, 10 volt-amperes at 120 V ac or dc
Feedback may be configured as a two wire transmitter or as a four wire active signal source. Two wire systems require a customer supplied external power supply. Four wire systems require 120 V ac supply to the actuator.	
Action on loss of input signal (Option 3)	Stays in place or moves to predetermined position with ac power supplied.
Action on loss of power	Stays in place.
Action on stall (Option 3)	Relay contacts open after 68 seconds of stall, remote signal available. Power to motor is turned off.

GENERAL SPECIFICATIONS

Switches	Cam controlled, field adjustable. Two limit switches (S3 & S4) open the motor circuit at end-of-travel limits. Two auxiliary switches (S1 & S2) provide external signaling as specified through connections made at the terminal board. All four switches are SPDT and are rated for 1 amp at 120 V ac.
Handswitch (Option 3)	Permits local electrical operation, independent of controller signal. The Handswitch is located beneath the control module cover on the control board. See "S1", Figure 9, p.26 for location on the control board.
Handwheel	Provides manual operation without electrical power. Non-rotating during automatic operation, does not require declutching mechanism.
Motor	120 V ac, single-phase, no burnout, non-coasting. Capable of 60 starts per minute.
Gear Train	Precision cut, heat-treated alloy steel and ductile iron. Self-locking and self-releasing, able to hold position at 150% rated torque.
Mechanical Stops	Prevent overtravel during automatic or manual operation. Mechanical Stops are external to the actuator.
Actuator Net Weight	25 lbs. (11 kg)
Max. Overhung Load	500 lbs. (227 kg)
Enclosure	Precision machined aluminum alloy castings, painted with corrosion resistant polyurethane paint, provide a rugged, dust-tight, weatherproof enclosure. Rated Type 4X, IP66*. Actuators designed for hazardous locations are also available.
Mounting Orientation	Can be mounted in any orientation.
Standards*	CSA Certified; CE Compliant; UKCA Compliant

*NOTE: May not be available with all options and models. For more information, please call Beck at 215-968-4600.

TABLE 1: SUMMARY OF GROUP 31 MODEL NUMBERS AND FEATURES

Beck Actuator Model #	Output Torque		Timing Sec./90°	Control Option	Hand-switch	Hand-wheel	Input Signal	Feedback Signal	Loss of Signal Function	Stall Sensing & Annunc'n
	(lb-ft)	(N•m)								
31-250	30	41	24	1	No	Yes	120 V ac	None	No	No
31-350	30	41	24	2	No	Yes	120 V ac	4-20 mA or 1-5 V	No	No
31-M50	30	41	24	3	Yes	Yes	4-20 mA or 1-5 V	4-20 mA or 1-5 V	Yes	Yes

INSTALLATION

SAFETY PRECAUTIONS



WARNING

Installation and service instructions are for use by qualified personnel only. To avoid injury and electric shock, do not perform any servicing other than that contained in this manual. Please read and understand the appropriate sections in this manual before attempting to install or operate your actuator.



CAUTION

Hot surfaces! Surfaces of equipment may be at an elevated temperature depending on operating conditions and environment. Allow to cool before servicing.

STORAGE INFORMATION

Beck actuators should be stored in their shipping cartons in a clean, dry area.

If it is necessary to store actuators outdoors for a long period of time, they should be stored above ground and covered with a waterproof cover. Do not stack cartons. Stored actuators should be checked periodically to ensure no condensation has formed in electronic and terminal compartments. Moisture damage while in storage is not covered by warranty.

UNPACKING

Group 31 actuators are shipped in standardized cardboard shipping containers and secured to a wooden platform.

INSTALLATION—ELECTRICAL

NOTE: All Beck actuators are shipped from the factory ready for installation. Each actuator is set-up and calibrated to the customer's specifications that were written into the equipment order. Electrical adjustments are generally not required before placing the actuator in operation.

Two N.P.T. conduit connections are provided for power and signal wiring to the actuator. Temporary plugs are installed in the conduit entrances at the factory for shipping only and are not intended for permanent use.

One 3/4" conduit is provided for signal wiring connections, and the other 3/4" conduit is provided for power and auxiliary switch connections. Conduits should be routed from below the actuator so that condensation and other contaminants flow

away from the conduit. Prior to actuator operation, all conduit entrances must be properly sealed in accordance with National Standards or Regulatory Authorities.

Power and signal wires must be routed to the actuator separately and be either shielded cables or installed in conductive conduit and/or cable trays.

Shielded, twisted pair cables should be used for signal connections to avoid being affected by electrical noise. These signal wires, based on Noise Susceptibility Level (NSL) per IEEE-518, fall into the level 1 classification. A braided shield will be more effective than a wrapped foil shield. Signal wire shields should be connected to the actuator casting grounding screw. If grounding at the signal source is required, then the shield should not be grounded at the actuator. Raceways such as conduits and trays have to be grounded at both ends to properly meet immunity requirements.

A clearly labeled terminal block on the top of the actuator is enclosed in a gasketed metal enclosure. Terminals will accommodate up to 12 AWG (3.31 mm²) wiring.



CAUTION

Always close covers immediately after installation or service to prevent moisture or other foreign matter from entering the actuator.

Refer to the wiring diagram furnished with your Beck actuator for proper AC power and signal connections. It is advisable to provide normal short circuit protection on the AC power line. A copy of the wiring diagram is shipped with each actuator and is fastened to the inside of the control end cover. If there is no wiring diagram available, you may obtain a copy from Beck by providing the serial number of your actuator.

Your Beck actuator has been supplied to match the signal source in your control loop. If it does not match, a 250 ohm input resistor may be added or removed to obtain the proper match. Consult the factory for details.

For maximum safety, and to comply with national and international standards, the Beck actuator body is required to be grounded. Use one of the two grounding terminals in the wiring compartment of the actuator to make this connection. Wire size 12 AWG (3.31 mm²) is recommended for this purpose.

INSTALLATION

COVER REMOVAL (HAZARDOUS LOCATION MODELS)

The control module cover may be removed by unscrewing it from the output section. To loosen, place the shaft of a large screwdriver between two lugs on the end of the cover and twist counterclockwise.

NOTE: The cover and output section threads are lubricated to permit easy removal of the cover. Do not wipe these threads clean. If it is necessary to replace the lubricant, use a thread lubricating compound such as Loctite Anti-Seize.



COVER REMOVAL (STANDARD MODELS)

The control module cover may be removed by loosening the four captive bolts (1/2" bolt heads) at the corners of the base of the cover.



POWER AND SIGNAL WIRING

The Group 31 actuator has a pair of 3/4" NPT threaded holes for signal and power conduit connection. A sealant must be used on threaded conduit connections to keep out moisture. Conduits should be routed from below the actuator so that condensation and other contaminants entering the conduit cannot enter the actuator.

All signal and power connections are made on the terminal board. Typical wiring connections for each Group 31 control option are described below. A specific wiring diagram is affixed to each actuator shipped.

All actuators are furnished with two auxiliary switches. Wiring connections for these are described separately. In addition, a safety ground is required for all actuators and is located on the baseplate of the control module.

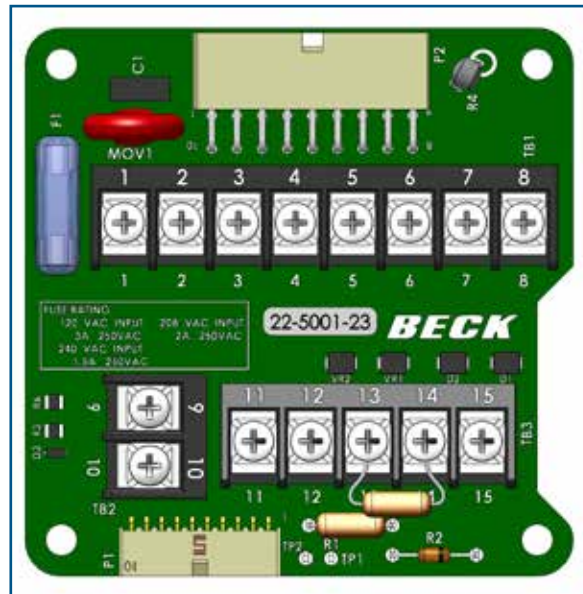

(Option 3 Terminal Board Shown)

NOTE: Customer wiring inside the control module must be properly dressed and routed to prevent damage to wires from the control module cover.

Figure 1

Option 1, Open/Close

Direct AC Control

Customer must supply three wires to directly control the actuator motor direction: One 120 V ac line to run Forward (terminal 10), one 120 V ac line to run Reverse (terminal 9), and one neutral (terminal 2).

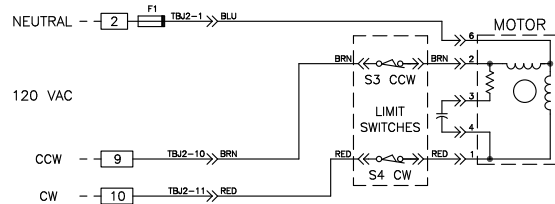

Option 2, Modulating

Direct AC Control with Loop Powered Position Feedback Signal

Customer must supply three wires to directly control the actuator motor direction: One 120 V ac line to run Forward (terminal 10), one 120 V ac line to run Reverse (terminal 9), and one neutral (terminal 2). Customer may supply two additional wires to monitor a loop powered position feedback signal. The loop powered position feedback signal must be connected to a "2-wire" type analog input that provides a dc voltage over the signal wires (a dc voltage power supply must be wired in series with the signal wiring). If the dc supply is 24 to 35 volts, connect to terminal 14 (-) and to terminal 15 (+). If the dc supply is 36 to 45 volts, reverse polarity and connect to terminal 14 (+) and to terminal 15 (-).

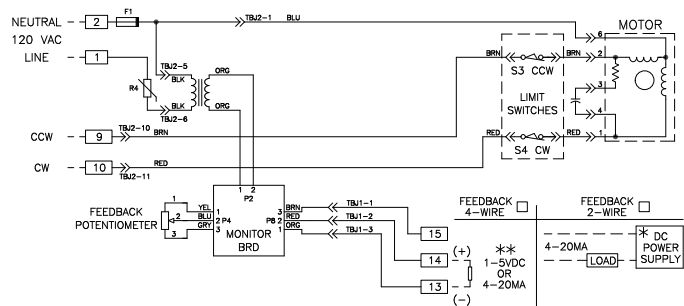

INSTALLATION

Direct AC Control with Actuator Powered Position Feedback Signal

Customer must supply three wires to directly control the actuator motor direction: One 120 V ac line to run Forward (terminal 10), one 120 V ac line to run Reverse (terminal 9), and one neutral (terminal 2). Customer may supply two additional wires to monitor the analog position feedback signal: Connect to terminal 13 (-) and to terminal 14 (+). If position feedback monitoring is desired, a 120 V ac line must be connected to terminal 1. The actuator's feedback circuit power supply

is derived from this 120 V ac line, therefore the feedback signal must be wired to a "4-wire" type, non-powered analog input.

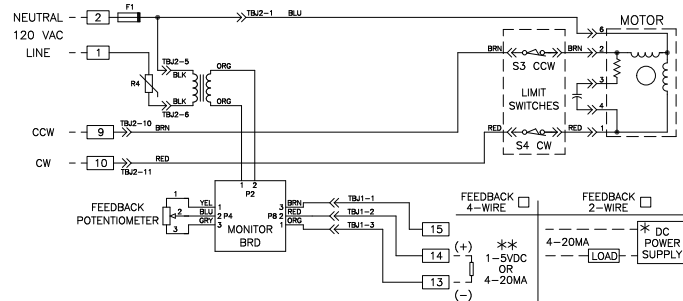

Option 3, Modulating Analog Position Control with Loop Powered Position Feedback Signal

Customer must supply two wires to power the actuator: One 120 V ac line (terminal 1), and one neutral (terminal 2). Customer must supply two wires for the analog input control signal: Connect to terminal 11 (-) and to terminal 12 (+). The loop powered position feedback signal must be connected to a "2-wire" type analog input that provides a dc voltage over the signal wires (a dc voltage power supply must be wired in series with the signal wiring). If the dc supply is 24 to 35 volts, connect to terminal 14 (-) and to terminal 15 (+). If the dc power supply is 36 to 45 volts, reverse polarity and connect to terminal 14 (+) and to terminal 15 (-).

neutral (terminal 2). Customer must supply two wires for analog control: Connect to terminal 11 (-) and to terminal 12 (+). Customer may supply two additional wires to monitor the analog position feedback signal: Connect to terminal 13 (-) and to terminal 14 (+). The actuator's feedback circuit power supply is derived from the 120 V ac line, therefore the feedback signal must be wired to a "4-wire" type, non-powered analog input.

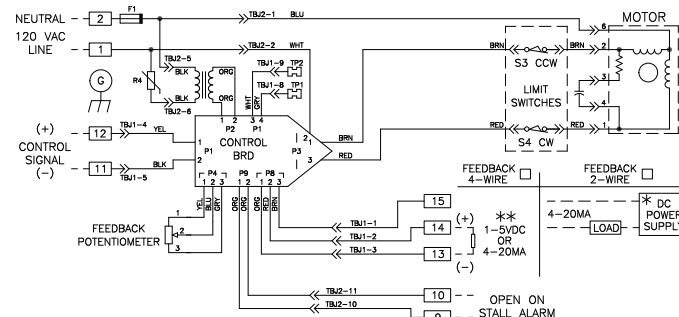

Analog Position Control with Actuator Powered Position Feedback Signal

Customer must supply two wires to power the actuator: One 120 V ac line (terminal 1), and one

Auxiliary Switches

Customer connections to the auxiliary switches are on the terminal board. Switch 1 connects to terminals 6, 7 and 8. Switch 2 connects to terminals 3, 4 and 5. Each switch is form C, rated for 1 amp at 120 V ac. There is no electrical connection between the two switches. S1 is factory set to operate 5 degrees before the CCW travel limit. S2 is factory set to operate 5 degrees before the CW travel limit. CCW and CW as viewed when looking into the output shaft. See p.20 for additional information about setting the auxiliary switches.

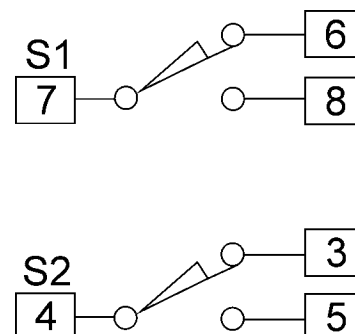

ACTUATOR MOUNTING

If your actuator includes a standard mechanical stop pin or a mechanical stop kit, the stop must be installed and adjusted prior to mounting the actuator to the driven shaft. If your actuator does not include a mechanical stop, skip directly to "INSTALLING AN ACUATOR", p.14.

MECHANICAL STOPS

The Group 31 actuator may be equipped with mechanical stops to prevent overtravel during automatic or manual operation. The mechanical stops prevent the output shaft from rotating more than 100 degrees. Unless otherwise specified at the time of order, Group 31 Option 2 & 3 actuators are shipped with the travel limit switches preset to 91 degrees of output rotation (90° for Option 1). This leaves approximately 5 degrees of shaft rotation between the limit switch and the mechanical stop at each end of travel.

Two types of mechanical stops are used on the Group 31. The standard mechanical stop is incorporated into mounting options A & B and is used for most Beck factory-mounted assemblies. It does not require any adjustment. An optional mechanical stop kit is available for use with a customer supplied mounting bracket or for nonstandard factory-mounted assemblies.

Standard Mechanical Stop, Installation and Adjustment (Mounting Options A & B, as shown on p.5; and Mounting Option E, p.6)

1. Position the actuator Handwheel and conduit connections in the desired orientation relative to the bracket or yoke. Turn the Handwheel until the mechanical stop pin in the output shaft is aligned with the slot in the bracket or yoke.
2. Bolt the actuator to the bracket or yoke and tighten the mounting bolts to 20 lb-ft (27 N•m).
3. Remove the control module cover.
4. Turn the Handwheel to position the pin to either the CW mechanical stop or the CCW mechanical stop (whichever location gives you access to the switch-cam shaft gear). Refer to the outline dimension drawings on p.4 for clockwise and counterclockwise travel direction.
5. Turn the Handwheel 1 turn off the mechanical stop (6-7 degrees of output shaft rotation).
6.
 - a. If the mechanical stop pin is at the CCW limit, grasp the cam assembly and rotate left to right until the S3 switch lever moves

from the low portion of the cam to the high portion of the cam. Tighten the set screw, if applicable.

- b. If the mechanical stop pin is at the CW limit, grasp the cam assembly and rotate right to left until the S4 switch lever moves from the low portion of the cam to the high portion of the cam. Tighten the set screw, if applicable.
7. Using the Handwheel, move the output shaft until the limit switch (either S3 or S4) just operates. Check for clearance between the mechanical stop pin and the bracket. Using the Handwheel, move the output shaft to the opposite limit switch (either S3 or S4) until the switch just operates. Check for clearance between the mechanical stop pin and the bracket. The travel from the point where the switches actuate until the pin contacts the mechanical stop should be approximately equal at both ends of travel.
 8. Connect 120 V ac power to the actuator and check operation in manual and automatic modes. Readjust the switch-cam shaft gear if necessary.
 9. Replace the control module cover and proceed to "INSTALLING AN ACTUATOR", p.14.

Mechanical Stop Kit, Installation and Adjustment (Mounting Options C & D, as shown on p.6)

Figure 2 depicts the parts of the mechanical stop kit as referenced in the following procedure.

Continued

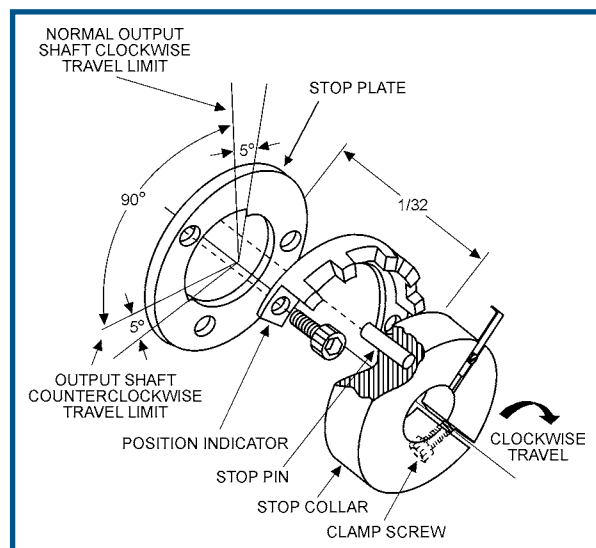

MECHANICAL STOP KIT

Figure 2

INSTALLATION

MECHANICAL STOP KIT, INSTALLATION AND ADJUSTMENT, CONT'D.

NOTE: The following procedure assumes a clockwise actuator operation.

1. Align the actuator with the mounting bracket, then align the stop plate and position indicator on the opposite side of the bracket. Bolt together.
2. Connect 120 V ac power to the actuator.
3. Run the actuator output shaft until it is stopped by the forward travel limit switch.
4. Position the stop collar so that it is approximately 5 degrees from the forward travel end of the mechanical stop as shown in Figure 2. Allow approximately 1/32" (0.8 mm) between the stop collar and stop plate.
5. Using a 5/16" hex wrench, tighten the stop collar clamp screw to 22 lb-ft (30 N•m) torque.
6. Operate the actuator to check that the output shaft travels through the proper range of motion.

If the actuator will travel in one direction only, check the travel limit switches. If one of the limit switch levers is up on the high portion of its cam, the actuator will not run in that direction.

If the actuator will not run in either direction, both travel limit switch levers are up on the high portion of their cams.

To correct, loosen the stop collar clamp screw, rotate the actuator output shaft with the Handwheel until the switches are on the low portion of their cams. Repeat steps 3 to 6.

If the actuator output shaft travels only a short distance in either direction and then stalls, the stop pin has been set at the wrong end of the slot in the stop plate. Loosen the stop collar clamp screw and rotate the stop collar until the stop pin is at the opposite end of the stop plate slot. Repeat steps 3 to 6.

INSTALLING AN ACTUATOR

The Group 31 actuator may be direct coupled to the shaft of the driven load, or connected to the load with a linkage. Procedures for each method follow.

The actuator may be mounted in any orientation. If your actuator includes a mechanical stop, the stop must first be installed and adjusted before proceeding with actuator installation (see "MECHANICAL STOPS", p.13).

NOTE: If your actuator was supplied with custom mounting hardware (from Beck), refer to your Valve Mounting Specification (VMS) sheet for customized installation instructions.

Direct Coupling, Installation and Adjustment

The Group 31 actuator output shaft can be coupled directly to the shaft of the driven load. In direct coupled applications, the torque required throughout motion range of the driven load must be less than the rated output torque of the actuator. This is particularly true for valves where seating torques may be relatively large or operating pressures are high.



EXAMPLE OF A DIRECT COUPLING

Figure 3

The actuator must be mounted to a bracket that will position the output shaft in line with the driven shaft. A split, clamp type coupling is normally used to couple the output shaft to the driven shaft. A Beck designed coupling with an adjustable position indicator is available. This coupling can be designed to fit on a variety of shaft sizes and types.

1. Mount the actuator to the mounting bracket (if not yet mounted).
2. Mount the actuator and mounting bracket to the final control element. Loosely tighten the mounting bracket bolts.
3. Connect 120 V ac power to the actuator (if not yet connected).
4. Run the actuator output shaft to the full reverse (minimum input signal) position.
5. Rotate the driven shaft to the full reverse position.

-
6. Assemble the coupling halves over the shafts and tighten the coupling bolts. (On the Beck designed coupling, the bolt torque is 35 lb-ft (47 N•m)).
 7. Cycle the actuator several times to allow the mounting bracket to position itself for good shaft to shaft alignment. Tighten the mounting bracket bolts.
 8. Place the position indicator band on the coupling so that it correctly indicates the position of the driven shaft. Clamp the indicator using a #6-32 screw and hex nut.

Linkage, Installation and Adjustment

Linkage connection to the driven shaft can be used if space is not available for direct coupling. Linkage coupling is also useful if you wish to characterize, or apply high seating torque to the driven shaft. The Group 31 actuator bracket must be bolted securely to a rigid mounting surface that will not bend when full linkage forces are applied.

In general, the best control of the driven shaft will result when the linkage is selected so that the full 90 degree travel of the actuator is used. This is true even if the driven shaft may travel less than 90 degrees. The requirements for a good linkage are:

1. It must be rigid enough to carry the link thrust without bending or deforming.
2. It should have a built-in means of adjustment so that the length of the connecting link can be changed a small amount.
3. Rod end bearings similar to the ones furnished on the Beck crank arm should be used at both ends of the connecting link. This type of device permits small angular misalignments, and helps prevent binding of the linkage.
4. The radius of the Beck crank arm must be calculated so that the crank arm will move the driven shaft lever through the correct arc as the actuator moves from 0 to 90 degrees.
5. Starting angles of the crank arm and driven lever and relative positions throughout the travel must be predetermined to calculate the proper length of the connecting links. A Beck LinkAssist™ computer printout can be furnished which provides details of all these variables. The Beck crank arm is not restricted by keyways or splines. Small or large adjustments to its position on the shaft are possible.

6. The actuator and driven shaft should be parallel and the linkage should be in a plane perpendicular to the shafts.

The following procedure is recommended to install the actuator and connect the linkage to the driven shaft:

1. Mount the actuator to the mounting bracket (if not yet mounted).
2. Rotate the driven shaft to the full reverse (valve or damper closed) position.
3. Set the driven shaft lever to its predetermined starting angle in relation to the driven shaft and actuator shaft centerline.
4. Adjust the connecting link to the predetermined length.
5. Connect the connecting link to the driven lever at the predetermined radius.
6. Connect 120 V ac power to the actuator (if not yet connected).
7. Run the actuator output shaft to its full reverse limit.
8. Slide the Beck crank arm onto the actuator output shaft. Do not tighten the clamping bolt.
9. Set the crank pin on the Beck crank arm to the predetermined radius.
10. Swing the crank arm into position to assemble the connecting link to the crank arm pin.
11. Tighten the crank arm clamping bolt to 20 lb-ft (27 N•m).
12. Lubricate rod end bearings.

Carefully move the actuator output shaft to the full forward (maximum input signal) position. Check that no binding occurs between the linkage, crank arm, driven shaft lever and surrounding obstructions. Also observe that the driven shaft rotates the proper amount. With the Auto-Manual switch (S2) set to Manual (M) (see page 17), check that the actuator reaches the forward limit switch and shuts off.

If binding in the linkage occurs due to excessive travel of the driven lever, reduce the crank pin radius rather than adjusting the connecting link length. Loosen the Beck crank arm clamping bolt and adjust the crank pin as necessary.

For an input control signal change, do not adjust the linkage. The span adjustment on the control board is used to adjust the amount of actuator rotation when a change in maximum input signal or span is required.

INSTALLATION

LINKAGE KITS AVAILABLE

Beck hex linkage kits are made to accommodate a wide variation in linkage lengths without having to modify end fittings. This adaptability makes it possible to order the actuator with the essential linkage end connections even though the exact linkage length may not be known until the actuator is mounted in place.

Linkage kits are also available in stainless steel for use in corrosive environments.

Hex Linkage kits are available for applications with linkage length requirements between 9" (229 mm) and 21" (533 mm). Each hex linkage kit comes complete with a rod end, studs, threaded hex bar, and jam nut hardware.

To order hex linkage kits, first obtain the approximate overall linkage length "A" in the hex linkage figure below. Select the kit part number from the corresponding table. For lengths beyond those listed in the table, contact your Beck sales engineer.



EXAMPLE OF A LINKAGE CONNECTION

Figure 4

Hex Linkage

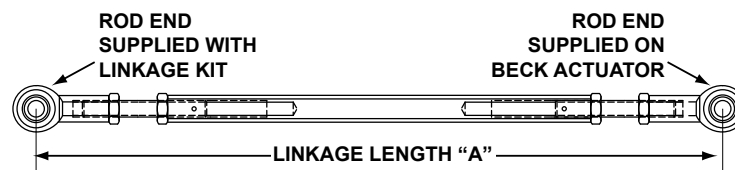

HEX LINKAGE KITS

Beck Actuator Model No.	Linkage Length "A"	Linkage Kit Part No.	Stainless Steel Linkage Kit Part No.	Hex Size	Rod End Thread
31-2__	9-12" (229-305 mm)	14-7990-22	14-7990-40	7/16" (11.11 mm)	5/16-24 UNF
31-3__	12-15" (305-381 mm)	14-7990-24	14-7990-42		
31-M__	15-18" (381-457 mm)	14-7990-26	14-7990-44		
	18-21" (457-533 mm)	14-7990-10	14-7990-30		

START-UP INSTRUCTIONS

NOTE: Beck actuators are shipped ready for installation—no calibration or switch adjustments are required. The procedures below are provided in the event that the application requirements are different from those originally specified.

(Note: If the limit switches have not yet been set in relation to the mechanical stop, refer to the appropriate section on p.13.)

After the wiring connections are made and the actuator is mounted, the actuator is ready to be tested for proper operation. See the graphic on the previous p. for component locations.

Turn on the power supply.

For Options 1 and 2, turn on the actuator 120 V ac control signal and observe that the output shaft travels through its desired stroke and moves in the proper direction. If the direction of travel is wrong, check the wiring connections and verify that the control signal is correct at the actuator. If the wiring and signal are correct, then reverse the direction of shaft travel. See p.20 for instructions.

For Option 3 units, set the Auto-Manual switch (S2) to Manual. Using the Handswitch (S1), run the actuator through its full stroke, first forward then reverse. Observe that the output shaft travels through its desired stroke. Note that the “F” and “R” LEDs on the control board light to indicate the direction of travel of the output shaft. The LEDs remain lit when the unit is stopped by the travel limit switches.

Set the Auto-Manual switch to Auto mode and operate the actuator by varying the control signal. Check that the output shaft travels in the proper direction for a change in control signal. If it does not, first check the wiring connections and verify that the control signal is correct at the actuator. If the wiring and signal are correct, then reverse the direction of travel. See p.20 for instructions. Note that the “F” and “R” LEDs light to indicate the direction the actuator output shaft is moving and are not lit when the shaft stops and the input and feedback signals are in balance.

When satisfied that the actuator travel is correct with reference to the input signals, the unit is ready to be placed in operation.

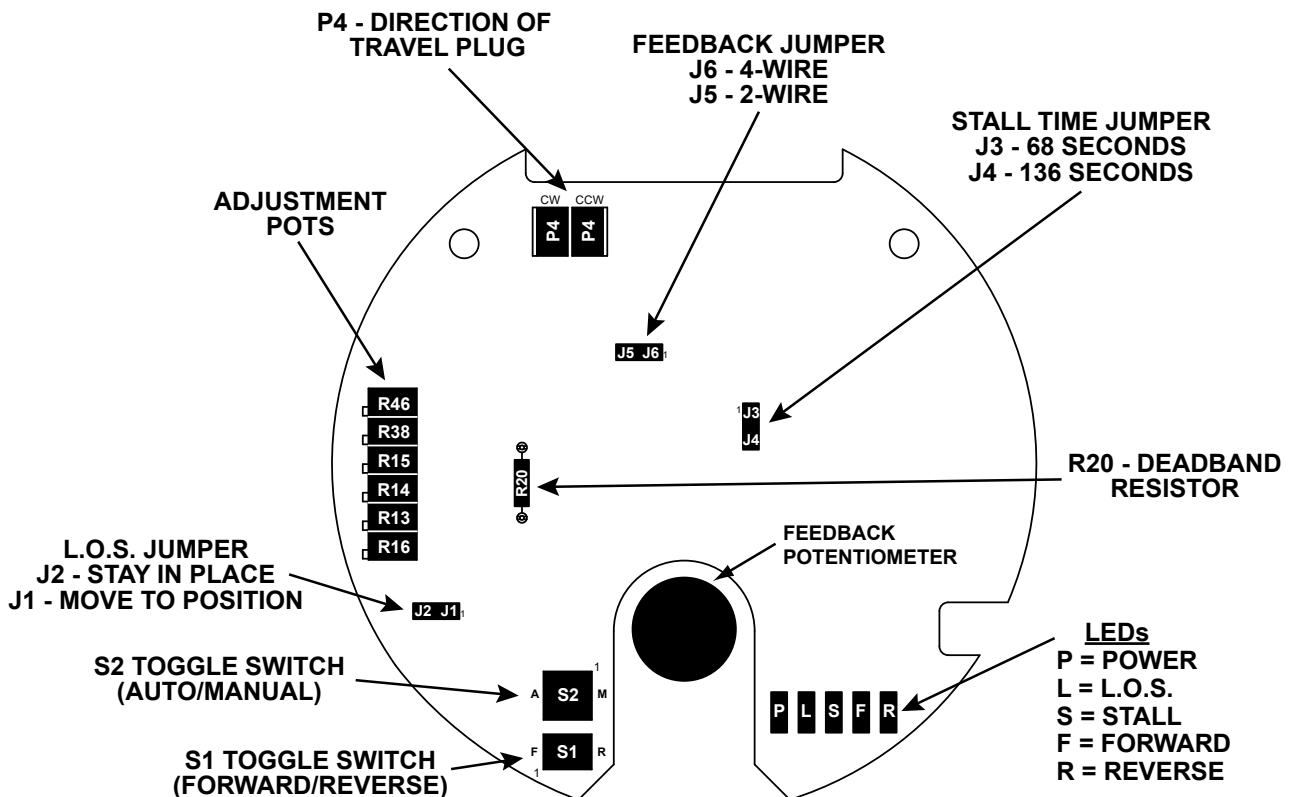

OPTION 3 CONTROL BOARD
(22-5001-21)

CALIBRATION

TRAVEL LIMIT SWITCH ADJUSTMENT

All Group 31 actuators are shipped with the travel limit switches factory adjusted for full 90 degree travel unless otherwise specified at the time of order. These switches must be set inside the 100 degree range of the output shaft mechanical stops. This will protect the actuator from stalling against the mechanical stops. The switches can be reset to limit the travel of the output shaft to any angle down to a minimum of 35 degrees for Option 1 and 60 degrees for Options 2 & 3.

The travel limit switches are opened and closed by cams that are driven by the actuator output shaft. Setting individual switches involves moving the actuator output shaft to the desired position then inserting a small screwdriver into one of the slots on the appropriate cam (see illustration below) and rotating until the cam operates the switch.

*Cam Adjustment Slots
(any one may be used)*

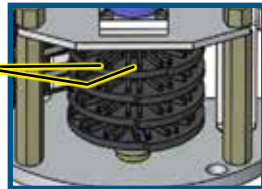

The following procedure recommends the use of a continuity meter to determine when the switch opens or closes. If such a meter is not available, it is possible to hear the switch click as the contacts open and close.



CAUTION

Do not attach the meter or attempt to move the switch cams until the actuator is disconnected from the line voltage, control signal voltage, and auxiliary switches are disconnected from external power sources. More than one disconnect switch may be required to de-energize the actuator before servicing.

Setting the CCW Travel Limit Switch (S3)

1. Remove the control module cover.
2. Move the output shaft to the desired CCW travel limit. For Options 1 & 2, skip to step 3. For Option 3: Set toggle switch S1 (see Figure 9, p.26) to Stop (center position). Set toggle switch S2 (see Figure 9, p.26) to Manual (M). Turn the Handwheel until the position feedback signal (measured across terminals 14 (+) & 13 (-)) decreases by $.08 \text{ mA} \pm .02$ ($20 \text{ mV} \pm 5$). The $.08 \text{ mA}$ is the over-travel range. NOTE: If direction of travel is set for CW on increasing demand, then turn the Handwheel until the output signal increases by $.08 \text{ mA} \pm .02$ ($20 \text{ mV} \pm 5$). Set toggle switch S2 to Automatic (A).
3. Disconnect all power from the actuator.
4. a. For actuators with Options 1 or 2, connect the continuity meter across terminals 2 and 9. Rotate the cam until the meter shows an increase in resistance from approximately 100 ohms to more than 1 M ohms (switch contacts open, switch clicks).
 - b. For actuators with Option 3, remove the cable tie holding the switch wires, remove the two wires from the CCW limit switch (S3 - Common & Normally Open terminal contacts), and attach the meter across these contacts. See Figure 5, p.19. Rotate the cam until the meter shows no continuity (switch contacts open, switch clicks).
5. Disconnect the meter and reconnect switch wires and actuator power.
6. Rotate the output shaft in the CW direction away from the CCW travel limit. Note the direction of rotation of the lobe of the cam. The correct cam lobe motion is away from the switch lever and the switch lever should be on the lower part of the cam. If this is not correct, return to Step 2 and reset the cam to the proper orientation.
7. Rotate the output shaft again, this time in the CCW direction. If the desired stopping point is reached at the CCW limit, the switch is properly set.
8. For Option 3, redress the switch wires and secure to the control board standoff with a cable tie.
9. Replace the control module cover.

Setting the CW Travel Limit Switch (S4)

1. Remove the control module cover.
2. Move the output shaft to the desired CW travel limit. For Options 1 & 2, skip to step 3. For Option 3: Set toggle switch S1 (see Figure 9, p.26) to Stop (center position). Set toggle switch S2 (see Figure 9, p.26) to Manual (M). Turn the Handwheel until the position feedback signal (measured across terminals 14 (+) & 13 (-)) increases by $.08 \text{ mA} \pm .02$ ($20 \text{ mV} \pm 5$). The $.08 \text{ mA}$ is the over-travel range. NOTE: If direction of travel is set for CCW on increasing demand, then turn the Handwheel until the output signal decreases by $.08 \text{ mA} \pm .02$ ($20 \text{ mV} \pm 5$). Set toggle switch S2 to Automatic (A).
3. Disconnect all power from the actuator.
4.
 - a. For actuators with Options 1 or 2, connect the continuity meter across terminals 2 and 10. Rotate the cam until the meter shows an increase in resistance from approximately 100 ohms to more than 1 M ohms (switch contacts open, switch clicks).
 - b. For actuators with Option 3, remove the cable tie holding the switch wires, remove the two wires from the CW limit switch (S4 - Common & Normally Open terminal contacts), and attach the meter across these contacts. See Figure 5, this p.. Rotate the cam until the meter shows no continuity (switch contacts open, switch clicks).
5. Disconnect the meter and reconnect switch wires and actuator power.
6. Rotate the output shaft in the CCW direction away from the CW travel limit. Note the direction of rotation of the lobe of the cam. The correct cam lobe motion is away from the switch lever and the switch lever should be on the lower part of the cam. If this is not correct, return to Step 2 and reset the cam to the proper orientation.
7. Rotate the output shaft again, this time in the CW direction. If the desired stopping point is reached at the CW limit, the switch is properly set.
8. For Option 3, redress the switch wires and secure to the control board standoff with a cable tie.
9. Replace the control module cover.

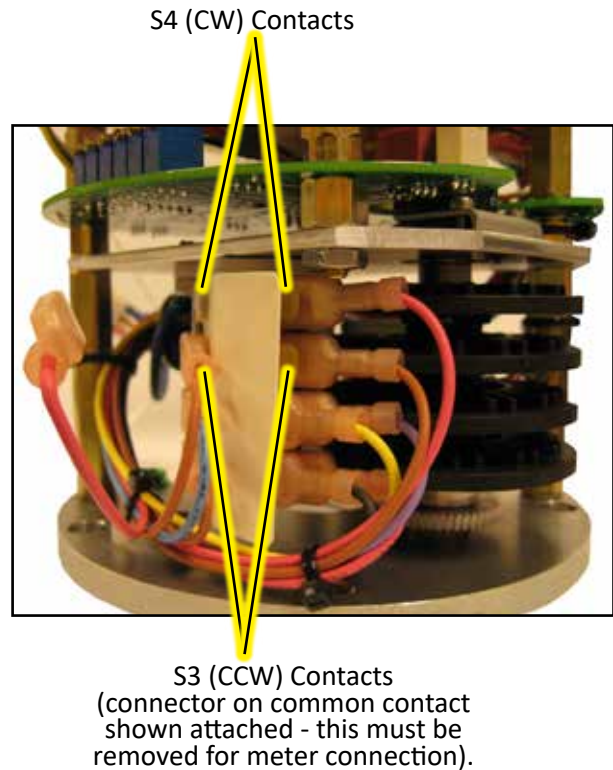

METER CONNECTIONS FOR LIMIT SWITCHES

Figure 5

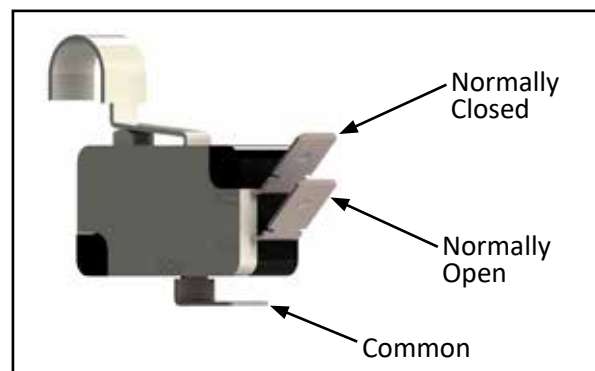

SWITCH DETAIL - TERMINAL CONTACTS

CALIBRATION

SETTING AUXILIARY SWITCHES

All Group 31 actuators are shipped with two auxiliary switches. They may be set at any point in the active range of actuator travel. Unless otherwise specified at time of order, these switches are factory set as follows:

Auxiliary switch S1 is set approximately 5% before the CCW limit.

Auxiliary switch S2 is set approximately 5% before the CW limit.

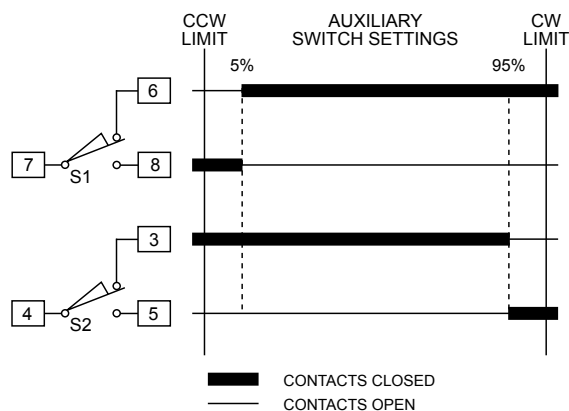

The auxiliary switches are opened and closed by cams that are driven by the actuator output shaft. Setting the switch position involves moving the actuator output shaft to the desired position then inserting a small screwdriver into one of the slots on the appropriate cam (see illustration below) and rotating until the cam operates the switch.

Cam Adjustment Slots
(any one may be used)

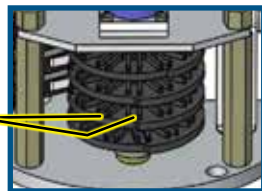

CAUTION

Do not attach the meter or attempt to move the switch cams until the actuator is disconnected from the line voltage, control signal voltage, and auxiliary switches are disconnected from external power sources. More than one disconnect switch may be required to de-energize the actuator before servicing.

The following procedure recommends the use of a continuity meter to determine when the auxiliary switch opens or closes. If such a meter is not available, it is possible to hear the switch click as the contacts open and close.

1. Remove the control module cover.
2. Move the output shaft to the desired switch position.
3. Disconnect power from the actuator.
4. Connect the continuity meter across the normally closed terminal on the terminal board (terminals 6 and 7 for S1, 3 and 4 for S2). Rotate the cam until the meter shows no continuity (switch contacts open, switch clicks).
5. Rotate the output shaft in the direction away from the switch position. Note the direction of rotation of the lobe of the cam. The correct cam lobe motion is away from the switch lever and the switch lever should be on the lower part of the cam. If this is not correct, return to Step 2 and reset the cam to the proper orientation.
6. Rotate the output shaft again to the desired switch position. If the contacts close, the switch is properly set.
7. Disconnect the meter.
8. Replace the control module cover and reconnect power.

CHANGING OUTPUT SHAFT DIRECTION OF TRAVEL

Direction of travel is defined as the direction of output shaft rotation produced by an increasing control (Demand) signal. Direction of rotation is determined by looking at the end of the output shaft. Unless otherwise specified at the time of order, the factory set output shaft rotation is clockwise in response to an increasing control (Demand) signal.

The following procedure should be followed to check or change the direction of travel of the output shaft.

This is up to a three step process depending on the actuator control option. The steps are as follows:

1. Interchange limit switch wires.
2. Calibrate position feedback signal.
3. Test/calibrate the Demand input signal.



CAUTION

Be sure the actuator is disconnected from the line voltage, control signal voltage, and auxiliary switches are disconnected from external power sources. More than one disconnect switch may be required to de-energize the actuator before servicing.

Interchange Limit Switch Wires

1. Remove the control module cover.
2. To reverse the output shaft direction of travel, the wires to the common terminals of travel limit switches S3 and S4 must be interchanged as shown in the table below. The common terminals are those farthest from the cams and closest to the labels (see Figure 6, this p.).

TRAVEL DIRECTION	S3 COMMON TERMINAL	S4 COMMON TERMINAL
CW	BROWN WIRE	RED WIRE
CCW	RED WIRE	BROWN WIRE

5. Locate plug P4 on the control board. It is a three wire plug with a grey, blue and yellow wire attached to it. See p.17 for location of plug P4 and below for plug detail (CW setting shown).

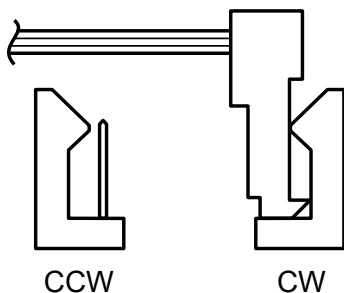

6. For clockwise rotation on an increasing signal, plug P4 must be attached to the terminal labeled CW. Note that this is a locking type plug and must be located properly in its receptacle. The tapered side of the plug must be against the tapered side of the receptacle.
7. For counterclockwise rotation on an increasing signal, plug P4 must be attached to the terminal labeled CCW.
8. If the direction of travel of the output shaft is changed; the feedback signal, the feedback potentiometer, and (for Option 3) the input signal must be recalibrated. See instructions beginning on p.22.

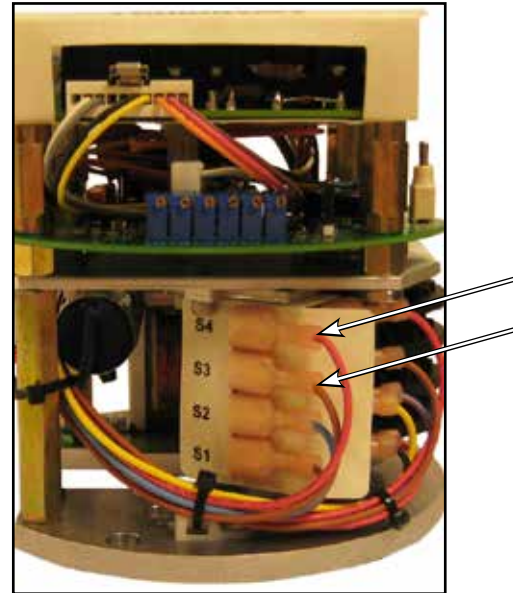

INTERCHANGE LIMIT SWITCH WIRES (S3 & S4) ON COMMON TERMINALS

Figure 6

FEEDBACK SIGNAL OPTIONS (OPTIONS 2 & 3 ONLY)

The feedback signal is an analog voltage or current signal proportional to the position of the actuator's output shaft. It may be used for remote position indication or for automatic control loop feedback. Actuators with Options 2 or 3 may be field connected to function as a two wire transmitter or as a four wire active current source. This circuit configuration is determined by the position of Jumper Plug J5/J6 located on the control board (J-J5 for 2-wire, J-J6 for 4-wire; see illustration on p.17). Unless otherwise specified at the time of order, all Group 31 actuators are shipped with the feedback circuit configured as a 4-wire system. Also, all Option 3 models are shipped with a 249 ohm resistor (R5) mounted between output signal terminals 13 and 14. This resistor is used to ensure proper operation of the control board when the feedback signal is not connected to a control room indicator. A summary of position feedback options, output signal ranges and control board and terminal board part numbers is provided in TABLE 2, p.22.

CALIBRATION

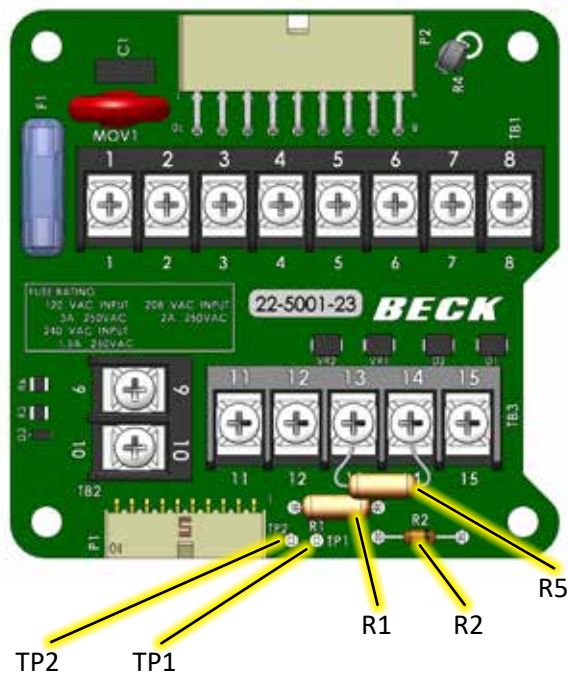

Option 3 Terminal Board

Figure 7

FEEDBACK SIGNAL CALIBRATION For 4-wire feedback only

Feedback signal calibration is necessary to ensure that the signal current or voltage correctly corresponds to the actuator output shaft position. All Group 31 actuators are shipped with the feedback calibrated for full 90 degrees of output shaft travel unless otherwise specified at time of order. The feedback signal may be specified as 4-20 milliamps or 1-5 volts when ordered or it may be changed at installation, using the following methods.

FOR OPTION 3: To convert a 4-20 milliamp configuration to 1-5 volts, remove the diode from position R2 on the terminal board and replace with a 249 ohm resistor. To convert a 1-5 volt configuration to 4-20 milliamps, remove the 249 ohm resistor and replace it with a 12 volt zener diode, Beck Part Number 13-2550-04. See Figure 7 for location of resistor R2.

FOR OPTION 2: To convert a 4-20 milliamp configuration to 1-5 volts, install a 249 ohm resistor in position R2. To convert a 1-5 volt configuration to 4-20 milliamps, remove the 249 ohm resistor from position R2.

TABLE 2

Fdbk. System	Control Option	Signal Config.		Ext. Pwr. Supply	Fdbk. Sig. Conn.		Jumper Loc.	Max. Ext. Load	Input Res. R1	Fdbk. Res. R2	Input Res. Ω	Output Res. Ω	Meter Conn. for Signal Cal.		
		Input	Output		Plus	Minus							Plus	Minus	
														<u>Millimeter Connection</u>	
2-Wire	2	120 V	4-20 mA	<35 V	15	14	J-J5	300 Ω	--	Diode	--	>1 M	14	Cust. - (Series)	
2-Wire	2	120 V	4-20 mA	>36 V	14	15	J-J5	800 Ω	--	Open	--	>1 M	15	Cust. - (Series)	
2-Wire	3	1-5 V	4-20 mA	<35 V	15	14	J-J5	300 Ω	--	Diode	2 M	>1 M	14	Cust. - (Series)	
2-Wire	3	1-5 V	4-20 mA	>36 V	14	15	J-J5	800 Ω	--	Open	2 M	>1 M	15	Cust. - (Series)	
2-Wire	3	4-20 mA	4-20 mA	<35 V	15	14	J-J5	300 Ω	249 Ω	Diode	249	>1 M	14	Cust. - (Series)	
2-Wire	3	4-20 mA	4-20 mA	>36 V	14	15	J-J5	800 Ω	249 Ω	Open	249	>1 M	15	Cust. - (Series)	
*4-Wire	2	120 V	4-20 mA	120 V	14	13	J-J6	500 Ω	--	Diode	--	>1 M	14	Cust. + (Series)	
4-Wire	3	1-5 V	4-20 mA	120 V	14	13	J-J6	500 Ω	--	Diode	2 M	>1 M	14	Cust. + (Series)	
*4-Wire	3	4-20 mA	4-20 mA	120 V	14	13	J-J6	500 Ω	249 Ω	Diode	249	>1 M	14	Cust. + (Series)	
														<u>Voltmeter Connection</u>	
4-Wire	2	120 V	1-5 V	120 V	14	13	J-J6	0.4 mA	--	249 Ω	--	249	14	13 (Parallel)	
4-Wire	3	1-5 V	1-5 V	120 V	14	13	J-J6	0.4 mA	--	249 Ω	2 M	249	14	13 (Parallel)	
4-Wire	3	4-20 mA	1-5 V	120 V	14	13	J-J6	0.4 mA	249 Ω	249 Ω	2 M	249	14	13 (Parallel)	

Control Option 2 = Control Board 22-5001-20 & Terminal Board 22-5001-27.

Control Option 3 = Control Board 22-5001-21 & Terminal Board 22-5001-23.

Note: For Split Range Operation, 1-5 V dc input can be calibrated 1-3 or 3-5 V dc. 4-20 mA input can be calibrated 4-12 or 12-20 mA.

Maximum Input Common Mode Range +15 V to -5 V as measured from Terminal 11 to Terminal 13.

*Typical for most applications.

FEEDBACK POTENTIOMETER AND SIGNAL CALIBRATION PROCEDURE

When properly adjusted, the feedback signal will be 20 milliamps (5 volts) with the actuator output shaft in the 100% (maximum input signal) position. At the 50% travel position, the signal should be 12 milliamps (3 volts) and at 0% (minimum input signal) 4 milliamps (1 volt).

The calibration procedure requires checking and/or setting the feedback potentiometer and two trim potentiometers located on the control board. The following paragraphs describe the procedure to check and set feedback signal calibration.

NOTE: The travel limit switches must be properly adjusted before the feedback signal is calibrated. The feedback signal must be calibrated before the input signal can be calibrated.

Tools required for calibration:

- mA/V dc voltmeter
- 3/32 inch screwdriver
- Large screwdriver

TABLE 2 lists the meter connections required for the calibration procedure.

Figure 8, p.25, and Figure 9, p.26, show the location of the jumper plug, feedback potentiometer, trim potentiometers, the Forward/Reverse and Manual/Automatic switches and plug P4 on the control boards.

Orienting the Potentiometer

(Note: Only use Steps 3–12 when changing direction of travel)

1. Remove the control module cover.
2. Connect the meter to read the feedback signal.

FOR CURRENT FEEDBACK APPLICATIONS: Connect the meter in series with the plus signal line of the control room indicator and the plus signal position (terminal 14 or 15; see TABLE 2 for correct meter polarity or reference the wiring diagram inside the control cover).

FOR VOLTAGE FEEDBACK APPLICATIONS: Connect the meter across the signal terminals 13 and 14. Terminal 14 is positive.

FOR INSTALLATIONS WITH NO REMOTE INDICATOR: Remove the resistor from between terminals 13 and 14 and connect the meter across these terminals. Terminal 14 is positive.

3. Position the actuator output shaft to the end of travel that corresponds to 4 mA (i.e., to the full CCW position if the actuator travel is set to travel CW on an increasing demand signal). Allow the over-travel limit switch to de-energize the motor at the limit.
4. Set the Forward/Reverse toggle switch (S1) to STOP (center position), Option 3 Control Board only.
5. Set the Manual/Automatic toggle switch (S2) to "M" (Manual), Option 3 Control Board only.
6. (Skip this step if you have just changed the direction of travel from p.21). Reverse plug connection P4. Note that plug P4 is a locking type plug and must be located properly in its receptacle. The tapered side of the plug must be against the tapered side of the receptacle. See Option 2 or 3 wiring diagram, p.34, for an illustration of the correct installation of the plug.
7. If the mechanical position of the feedback potentiometer has not been set:
 - a. Move the actuator output shaft to the minimum input signal position.
 - b. Disconnect all power to the actuator.
 - c. Loosen feedback potentiometer clamp screws.
8. Turn trim potentiometer R38 clockwise 20 turns (to limit), then rotate it 8 full turns counterclockwise.
9. Turn trim potentiometer R46 clockwise 20 turns (to limit), then rotate it 8 full turns counterclockwise.
10. Reconnect actuator power.
11. Turn the feedback potentiometer until the output signal reads 20 + 0.5 milliamps (5 + 0.1 volts on units configured for voltage output).
12. Tighten the feedback potentiometer clamp screws to hold the potentiometer in position. The potentiometer orientation is now complete.
13. Position the actuator output shaft to the end of travel limit that corresponds to 4 mA (i.e., to the full CCW position if the actuator travel is set to travel CW on an increasing demand signal). Allow the over-travel limit switch to de-energize the motor at the limit.
14. Turn trim potentiometer R46 counterclockwise until the output signal reads 3.95 mA (1 volt on units configured for voltage output).
15. Move the output shaft towards the maximum input signal position.

CALIBRATION

SIGNAL CALIBRATION, CONT'D.

16. Position the actuator output shaft to the end of travel limit that corresponds to 20 mA (i.e., to the full CW position if the actuator travel is set to travel CW on an increasing demand signal). Allow the over-travel limit switch to de-energize the motor at the limit.
17. Turn trim potentiometer R38 counterclockwise until the output signal is 20.05 mA (5 volts on units configured for voltage output).
18. Repeat steps 13 through 17 until the feedback signal is calibrated. Adjusting R38 and R46 clockwise increases the signal while counterclockwise decreases the signal.
19. Reinstall resistor between terminals 13 and 14 (if used).

NOTE: The input signal is calibrated relative to the feedback signal. Therefore the shaft travel limit switches must be properly adjusted and the feedback signal calibrated before the input signal can be calibrated.

DEMAND INPUT SIGNAL CALIBRATION (Option 3 only)

NOTE: All actuators are fully calibrated at the factory and should require no adjustment; however, if necessary, calibration may be tested as follows:

Apply 4.00 mA; actuator should position at 4.00 mA \pm .16 mA.

Apply 20.00 mA; actuator should position at 20.00 mA \pm .16 mA.

If adjustments are required, see below.

Input signal calibration is necessary to ensure that the input signal correctly corresponds to the position of the actuator output shaft.

Unless otherwise specified at the time of order, all Group 31 actuators are shipped with the input signal calibrated for full 90 degrees of output shaft travel and the input signal range set to 4 to 20 milliamps. A 1 to 5 volt input signal may be specified at time of order or changed at installation. To convert a 4-20 milliamp input configuration to 1-5 volts, remove input resistor R1 from the terminal board. To convert a 1-5 volt input configuration to 4-20 milliamps, install a 249 ohm resistor in position R1. See Figure 7, p.22, for the location of R1.

When properly adjusted, the actuator output shaft will be in the 100% position when the input signal is 20 milliamps (5 volts). At 50% position, the input signal should be 12 milliamps (3 volts) and at 0% position, 4 milliamps (1 volt).

Split signal operation is also possible. The control board can be adjusted to produce full actuator travel with 50% of the input signal, permitting two actuators to respond independently from the same signal source. Split signal ranges are:

- 4 to 12 milliamps (1 to 3 volts)
- 12 to 20 milliamps (3 to 5 volts)

It is also possible to calibrate the control board to give a span anywhere between 8 and 16 milliamps (2 to 4 volts), with the minimum signal between 4 and 12 milliamps (1 to 3 volts). The maximum input signal may be anywhere between 12 and 20 milliamps (3 to 5 volts) as long as the span is at least 8 milliamps (2 volts).

Tools required for calibration:

mA/V dc voltmeter

3/32 inch screwdriver

Large screwdriver

Table 2, p.22, lists the meter connections required for the calibration procedure.

The calibration procedure requires setting two trim potentiometers R13 and R14 on the control board. Figure 9, p.26 (or the illustration on p.17), show the location of these potentiometers and the S2 (Manual/Automatic) toggle switch.

1. Remove the control module cover.
2. Set the S2 toggle switch to Automatic (A).
3. Connect a signal source to terminals 11 and 12, positive to 12.
4. Connect the meter to read the feedback signal in accordance with Table 2, p.22.

FOR INSTALLATIONS WITH NO REMOTE INDICATOR: Remove the resistor from between terminals 13 and 14 and connect the meter across these terminals. Terminal 14 is positive.

5. Connect 120 V ac to terminals 1 and 2.
6. Turn on the 120 V ac power supply.
7. Set the input signal to 100 percent, that is 20 milliamps (5 volts) maximum.
8. If the position feedback is less than 19.84 mA (4.96 V), then trim R13 clockwise. If greater than 20.16 mA (5.04 V), trim R13 counter-clockwise.

NOTE: As the output signal approaches 20.00 mA, R13 will become more sensitive; at that point, minor adjustments followed by cycling the demand signal may be required to achieve the desired results.

9. Set the input signal to zero percent, that is 4 milliamps (1 volt).
10. If the position feedback signal is greater than 4.16 mA (1.04 V), then trim R14 counter-clockwise. If less than 3.84 mA (0.96 V), trim R14 clockwise.

NOTE: As the output signal approaches 4.00 mA, R14 will become more sensitive; at that point, minor adjustments followed by cycling the demand signal may be required to achieve the desired results.

11. Repeat Steps 7–10 as required.
12. Calibration is complete.
13. Replace the control module cover.

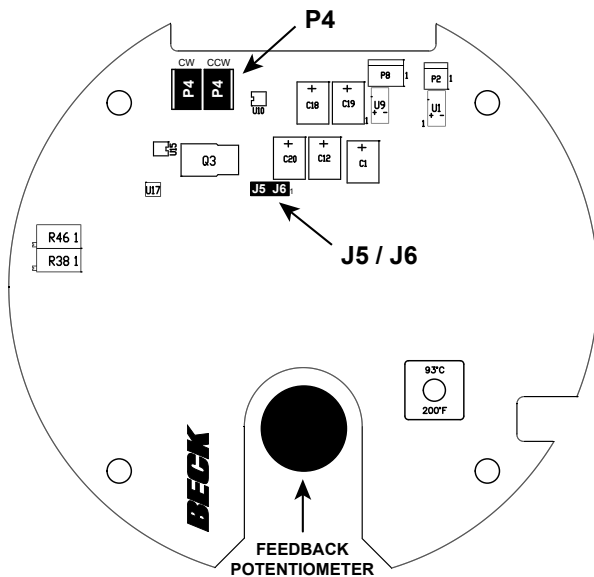

Option 2 Control Board

Figure 8

CALIBRATION

SETTING LOSS OF SIGNAL FUNCTION Option 3 only

The Loss of Signal (LOS) feature gives the actuator the ability to move the output shaft to a predetermined position if the input signal falls below a predetermined value, as long as ac power is supplied. LOS can function in two ways:

1. Actuator will stay in its last position when the signal was lost.
2. Actuator will move to a position determined by the setting of trim potentiometer R16.

The LOS function will start when the input signal falls below the level set by trim potentiometer R15. The range of adjustment for this input signal trigger level is from zero milliamps input to 8 milliamps (2 volts). The choice of having the actuator stay in place or move to a position is determined by the position of jumper plug J1/J2 on the control board. (J1 moves to a predetermined position, J2 stays in place.)

Unless otherwise specified at time of order, all Group 31 actuators are shipped with the LOS input signal trigger level set to 3.4 milliamps (.85 volts). Jumper plug J1/J2 is set in the J2 or stay in place position. The move to position trim potentiometer (R16) is set so that if this function is chosen the actuator will move to the minimum input signal position.

NOTE: The LOS position is adjusted relative to the feedback signal. The feedback signal must be calibrated before the LOS can be set.

Tools required for setting LOS:
 mA/V dc voltmeter
 3/32 inch screwdriver
 Large screwdriver

Figure 9 shows the location of the jumper plug J1/J2 and the trim potentiometers R15 and R16 on the control board. Figure 7, p.22, shows the location of test points TP1 and TP2.

1. Remove the control module cover.
2. Verify the position of jumper plug J1/J2. Use J1 to select the move to position function or J2 to select the stay in place function.



CAUTION
 Never use both J1 and J2—damage will result.

3. Connect 120 V ac to terminals 1 and 2.
4. Turn on 120 V ac power supply.
5. Connect the voltmeter between test points TP1 and TP2. TP2 is positive.
6. Turn trim potentiometer R15 until the desired trigger level is measured on the voltmeter. The voltage scale is:

0 V = 0 milliamps

1 V = 4 milliamps

2 V = 8 milliamps

Turn the potentiometer clockwise to increase the trigger voltage, counterclockwise to decrease the trigger voltage.

7. Disconnect the input signal (if connected) so that the LOS becomes active.
8. If LOS is set to stay in place, the actuator output shaft will not move.
9. If LOS is set to move to position:

Turn trim potentiometer R16 until the desired output shaft position is reached. Turn the potentiometer clockwise to increase the output shaft position, counterclockwise to decrease the output shaft position.

10. Replace the control module cover.

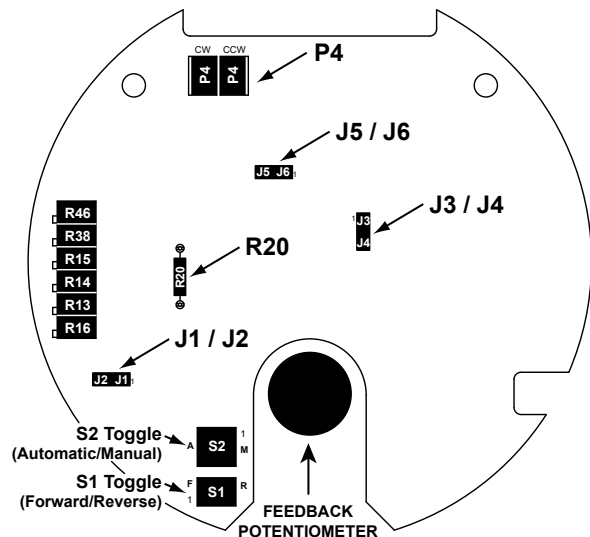

Option 3 Control Board

Figure 9

STALL FUNCTION

Option 3 only

The Stall function for Group 31, Option 3 actuators provides protection for the actuator motor and gearing in the event of a stalled condition. The time to stall is set at 68 seconds, after which power to the motor is turned off. The timer resets automatically when the signal reverses or the Handswitch is moved from Auto to Manual.

The stall time of 68 seconds is set by the factory and requires Jumper J3/J4 on the control board (see Figure 9, p.26 or illustration on p.17) to be set to the J3 position. If this Jumper is set to the J4 position (not recommended), the time to stall will be increased to 136 seconds.

DEADBAND ADJUSTMENT

Group 31, Option 3 actuators are shipped with the deadband set to 1% of span to satisfy the requirements of most control systems. If excessive process and/or signal noise is present, the actuator may be subject to unnecessary cycling. It is recommended that excessive noise be reduced at the source in order to prevent unnecessary cycling. This will improve process control and prolong component life.

If it is not possible to eliminate the excessive noise, the actuator's deadband can be widened; however, this will reduce the resolution of the actuator. Widening the deadband can be accomplished by changing the value of resistor R20 on the Control Board (see Figure 9, p.26). The recommended procedure is to solder a second resistor in parallel with the existing resistor R20. The new resistance value, recommended parallel resistor and corresponding deadband are listed in the following chart.

R20 Ω	Parallel Resistor Ω	Effective Resistance Ω	Dead- band
1,000,000			1.0%
1,000,000	2,000,000	666,000	1.5%
1,000,000	1,000,000	500,000	2.0%
1,000,000	665,000	400,000	2.5%

SHORT-STROKE OPERATION (Reducing Full Stroke Travel Distance)

Typically, it is best to use the full travel of the actuator in response to the 0–100% Demand input signal. However, some set-ups and applications make it necessary to reduce this response to less than the maximum full travel distance. To reduce the full travel of the actuator (short-stroke), use the following procedure:

First, adjust the 100% Travel Limit Switch to the setting necessary to accommodate the reduced travel range (see p.18). Note: If necessary, both the CCW (S3) and CW (S4) Switches may be adjusted.

Next, perform the Feedback Signal Calibration in relation to the new switch setting(s) to complete setting the reduced travel distance (see p.22).

MAINTENANCE Troubleshooting

CONDITIONS	POSSIBLE CAUSES	CORRECTIONS
1. Actuator will not run in either direction with input signal applied.	<ul style="list-style-type: none"> a. S1 toggle switch left in Manual (M) position. b. No 120 V ac line supply. No lamps lit on control board. c. Fuse F-1 open. No lamps lit on control board. d. External auto/man switch in wrong position (Position-all). e. Torque on driven load shaft exceeds actuator torque rating. "S" LED on. f. Input signal below range or reversed. "L" LED on. g. Control board failure. 	<ul style="list-style-type: none"> a. Return S1 toggle switch to Automatic (A) position. b. Check fuses and switches in power panel. c. Check for possible shorts, then replace fuse. Use only Beck part no. 11-1370-10 for proper protection of triacs. d. Return switch to auto position. e. Check operation with Handswitch and remove obstruction. f. Input signal voltage between terminal 11 and 12 (+) must be between 1-5 V dc. g. Replace control board.
2. Actuator runs in one direction only in Auto (A) and both directions with S2 toggle switch in Forward (F) and Reverse (R).	<ul style="list-style-type: none"> a. Zero adjustment incorrect. b. Loss of signal feature activated and set to actuator shaft to full forward or reverse position. "L" LED on. c. Loss of feedback signal. d. Control board failure. 	<ul style="list-style-type: none"> a. Readjust Zero. See calibration instructions, p.22. b. Check input signal against LOS trigger. c. Check feedback signal at terminals 13, 14, or 15. d. Replace control board.
3. Actuator runs in the wrong direction with input signal applied.	<ul style="list-style-type: none"> a. Input signal reversed. "L" LED on. b. Wiring to limit switches reversed. 	<ul style="list-style-type: none"> a. Check polarity of input signal. Terminal 12 is positive, 11 negative. b. Check limit switch connections. See Limit Switch adjustment, p.18.
4. Actuator shaft position oscillates.	<ul style="list-style-type: none"> a. Excessive noise on input signal. b. Control board failure. 	<ul style="list-style-type: none"> a. Check input signal. b. Replace control board.
5. Actuator does not stop at normal or desired limit of shaft travel.	<ul style="list-style-type: none"> a. Span or Zero adjusted incorrectly. b. Limit switches adjusted incorrectly. c. Loss of input signal. "L" LED on. d. Limit switch failure. 	<ul style="list-style-type: none"> a. Check control board calibration. See calibration procedure, p.22. b. Readjust limit switches. See limit switch adjustment, p.18. c. Restore input signal to actuator. d. Replace limit switch. See p.32 for actuators with Option 1, or 33 for actuators with Options 2 or 3.
6. Loss of signal feature does not function.	<ul style="list-style-type: none"> a. Control board failure. 	<ul style="list-style-type: none"> a. Replace control board. See p.33.
7. Actuator moves to full retract or extend position and stays.	<ul style="list-style-type: none"> a. S1 toggle switch left in Forward (F) or Reverse (R) position & S2 toggle switch set to Manual (M). b. Loss of input signal when LOS move to position is selected. "L" LED on. c. Loss of feedback signal d. Control board failure. 	<ul style="list-style-type: none"> a. Set S1 toggle switch to Stop (center) position & set S2 toggle switch to Automatic (A). b. Restore input signal to actuator. c. Check feedback signal at terminals 13, 14 or 15. d. Replace control board. See p.33.
8. Actuator movement erratic while driving from full reverse to full forward and runs normally from full forward to full reverse.	<ul style="list-style-type: none"> a. Feedback potentiometer dirty. Loss of wiper contact moves actuator in reverse direction. b. Feedback potentiometer open. 	<ul style="list-style-type: none"> a. Replace feedback potentiometer. See p.33. b. Replace feedback potentiometer. See p.33.
9. Actuator moves uncontrollably to some position then oscillates.	<ul style="list-style-type: none"> a. Feedback potentiometer open. 	<ul style="list-style-type: none"> a. Replace feedback potentiometer. See p.33.

CONDITIONS	POSSIBLE CAUSES	CORRECTIONS
10. Power (P) LED light out.	a. No power. b. Control section transformer failure.	a. Check power sources. b. Replace control section transformer. See p.33.
11. Feedback signal decreases when it should increase.	a. Plug P4 in wrong position on control board.	a. Check feedback calibration procedure. See p.22.
12. Feedback signal does not reach maximum signal, but low end calibration is correct.	a. Output is overloaded: -- load resistance is too low for voltage range. -- load resistance is too high for current range. b. Low voltage. c. Feedback potentiometer not set correctly. d. Incorrect actuator feedback configuration.	a. Check load resistance against suggested feedback signal terminal hookup. b. Check line voltage at terminal board. c. Check feedback calibration procedure. See p.20. d. Check feedback calibration procedure for correct R2 component on terminal board. See p.22.
13. Actuator does not reach desired travel limit.	a. Mechanical stop improperly set. b. Physical obstruction, e.g. valve jammed or load exceeds rating of actuator. "S" LED on.	a. Check mechanical stop installation and adjustment procedure. See p.13. b. Check operation with Handswitch and remove obstruction.
14. Motor continues running after 68 seconds of stall.	a. Jumper J3/J4 on control board is set to J4.	a. Set Jumper J3/J4 to the J3 position.
15. L.O.S. "L" LED is lit.	a. Input signal below range or reversed.	a. Input signal voltage between terminal 11 and 12 (+) must be between 1-5Vdc.
16. Stall "S" LED is lit.	a. Torque on driven load shaft exceeds actuator torque rating.	a. Check operation with Handswitch and remove any obstructions.

TABLE 3: LEVEL 1 MAINTENANCE REPLACEMENT PARTS
STANDARD MODEL

Model	60 Cycle Power		50 Cycle Power		Output Section	Cover	Gasket	Fuse	Optional Stop Kit
	Timing (sec./90°)	Control Module	Timing (sec./90°)	Control Module					
31-250	24	23-2102-21	29	23-2102-24	23-2201-01	11-0990-20	10-8080-02	n/a	20-3112-01
31-350	24	23-2102-22	29	23-2102-25	23-2201-01	11-0990-20	10-8080-02	11-1370-18	20-3112-01
31-M50	24	23-2102-23	29	23-2102-26	23-2201-01	11-0990-20	10-8080-02	11-1370-18	20-3112-01

EXPLOSION-PROOF MODEL

Model	60 Cycle Power		50 Cycle Power		Output Section	Cover	"O" Ring	Fuse	Optional Stop Kit
	Timing (sec./90°)	Control Module	Timing (sec./90°)	Control Module					
31-250	24	23-2102-21	29	23-2102-24	23-2200-05	11-0995-05	14-9840-08	n/a	20-3112-01
31-350	24	23-2102-22	29	23-2102-25	23-2200-05	11-0995-05	14-9840-08	11-1370-18	20-3112-01
31-M50	24	23-2102-23	29	23-2102-26	23-2200-05	11-0995-05	14-9840-08	11-1370-18	20-3112-01

MAINTENANCE

LUBRICATION

The Group 31 actuator is designed so that no field maintenance of the output section is required. The gear train and bearings are permanently lubricated and do not require any relubrication. Field disassembly of the output section is not recommended. If the rotor is removed from the motor it will result in a loss of motor torque that can only be restored by returning the complete output section to the factory to be remagnetized.

LEVEL 1 MAINTENANCE

Removal and replacement of: Output section, control module, gasket (or "O" ring), mechanical stop and fuse

TABLE 3, p.29, lists the part numbers of the assemblies and parts that are replaceable on the Group 31 actuator assembly.



CAUTION

Be sure the actuator is disconnected from the line voltage, control signal voltage, and auxiliary switches are disconnected from external power sources. More than one disconnect switch may be required to de-energize the actuator for servicing.

If replacing the entire output section and the control module, refer to the next section on p.31. If the output section or control module is replaced, it will be necessary to check the setting of the travel limit switches, auxiliary switches and signal calibration. For a Group 31 already installed, refer to Figure 10 and follow the steps below to remove and replace parts or subassemblies from the actuator.

1. Disconnect actuator from line voltage and auxiliary switches from external power sources.
2. Remove the control module cover.
3. To replace the fuse, remove the fuse cover. Use a small screwdriver to lift the cover off. Remove and replace the fuse and replace the cover.

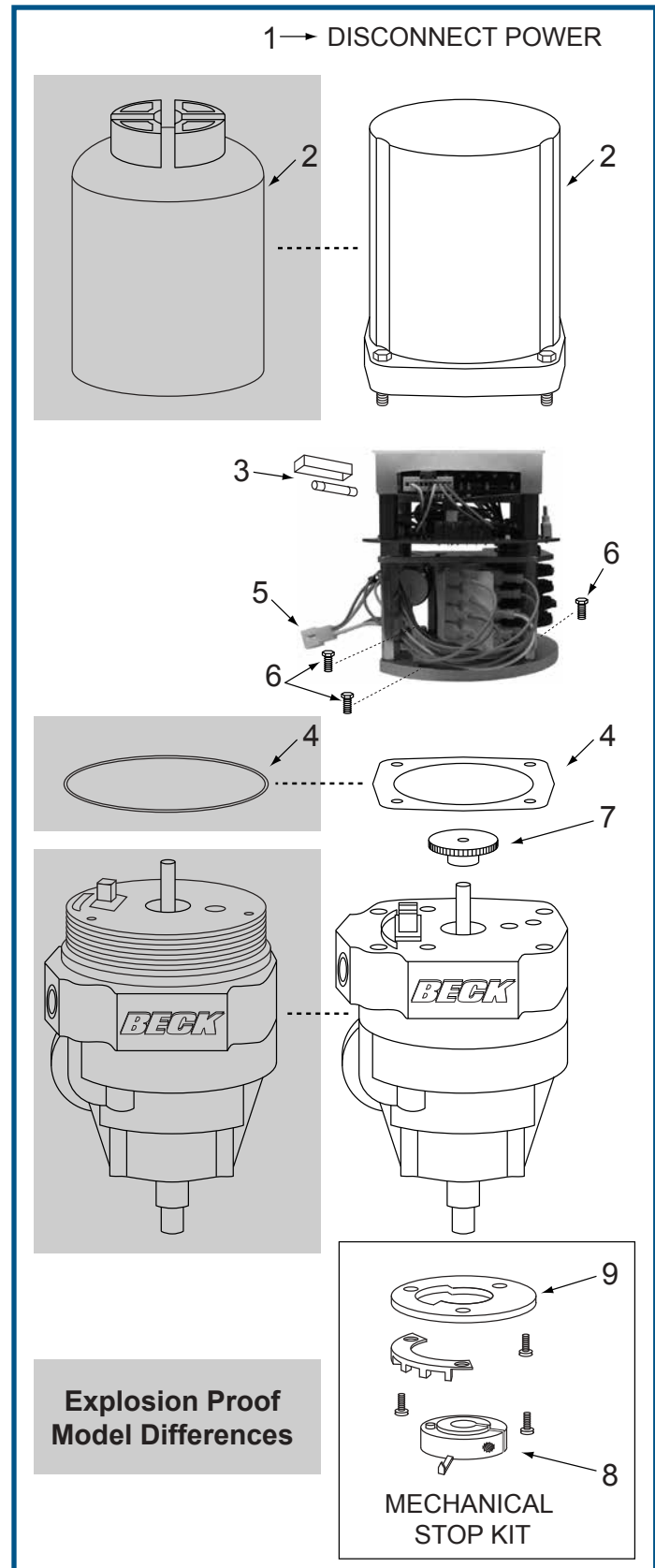

Figure 10

-
4. To help protect the internal components, replace the gasket (or "O" ring) if worn or damaged. Remove the gasket being replaced and clean the area. Use 3M #847 Rubber and Gasket Adhesive (or equivalent) to glue the new gasket into place; or slide the replacement "O" ring completely over the output section threads.
 5. Disconnect all power and signal wiring from the wiring terminals and ground lugs. Disconnect the six pin connector from the motor plug on the back of the output section casting.
 6. Remove the three #10-32 Socket Head screws that hold the control module assembly to the back of the output section. Use 5/32" hex wrench. Lift the control section approximately 1/4 inch and slide sideways away from the output section.
 7. Remove the gear from the control section actuator shaft. Use a 1/16" hex wrench.
 8. Loosen the 3/8-16 socket head screw that holds the stop collar to the actuator output shaft. Remove the stop collar. Refer to Mechanical Stop Installation and Adjustment instructions for correct procedure to reinstall and set the stop collar. See p.13.
 9. Remove the three 3/8-16 socket head screws that hold the stop plate and position indicator to the output end of the actuator. Use a 5/16" hex wrench. Refer to Mechanical Stop Installation and Adjustment instructions for correct procedure to reinstall and set the stop collar. See p.13.
 5. Replace the gear on the control shaft and position the top of the gear 3/4" from the output section body. Tighten the gear set screw on the shaft flat. Rotate the gear back and forth slightly as the set screw is tightened to ensure the set screw is perpendicular to the flat.
 6. Grasp the cam assembly on the replacement control module and rotate from left to right until the S3 switch lever moves from the low portion of the cam to the high portion of the cam. Maintain this cam position.
 7. Slide the cutout section of the control module base plate under the gear on the control module actuator shaft and around the electrical connector. Position the bushing that protrudes from the bottom of the base plate in the locating hole on the output section. Install the three #10-32 socket head cap screws and tighten to 36 lb-in (407 N•cm). Plug the control module into the output housing.
 8. Ensure the proper gap is set between the switch levers and cams on the replacement control module switch assembly. This is accomplished by *just* loosening the two socket head cap screws in the switch mounting plate (see Figure 12, p.32, Step 5 for location). The switch assembly rotates around one screw (the other is in a slot). To set the gap, place a .030" (.75 mm) shim between switch S3 and its cam. The switch should be on the low (or minimum) radius of the cam. Position the switch assembly until the switch is just actuated. Tighten both screws to 10 lb-in (1 N•m) torque and remove the shim.

REPLACING THE OUTPUT SECTION AND THE CONTROL MODULE

1. Position the output section so that the actuator Handwheel is in the desired orientation.
2. If the mechanical stop is by means of a pin in the output shaft, turn the Handwheel until the pin is aligned with the slot in the mounting bracket/yoke, with the Handwheel in the desired orientation.
3. Bolt the output section to the bracket/yoke using the three 3/8-16 bolts and torque the bolts to 20 lb-ft (27 N•m).
4. If the mechanical stop design is as described in Step 2, turn the Handwheel clockwise until the mechanical stop pin contacts the bracket. If the optional mechanical stop kit is used, proceed to step 5.
9. Connect 120 V ac power to the actuator and check the travel in the manual mode. Check for clearance between the mechanical stop pin and the bracket/yoke at approximately both ends of travel. This clearance should be equal at both ends of travel. If not, loosen the set screw on the switch-cam shaft gear and reposition cams to make the clearance equal.
10. If the optional mechanical stop kit is used, refer to Mechanical Stop, Installation and Adjustment on p.13.
11. Connect the control signal to the actuator and check for proper operation in the automatic mode. If travel direction is not correct with an increasing signal refer to Changing Output Shaft Direction of Travel on p.20.

MAINTENANCE

LEVEL 2 MAINTENANCE (Option 1 parts)

The following parts are replaceable on the Option 1 control module:

Part Name	Part Number
Terminal Board	22-5001-26
Switch Assembly	20-3200-14
Gear, Switch Shaft	14-9940-21
Motor Capacitor (60 hz)	14-2841-02
Motor Capacitor (50 hz)	14-2842-03

Refer to Figure 12 and follow the steps required to remove parts from the Option 1 control module. Reverse the steps to replace parts.



CAUTION

Do not attempt to replace control module parts with the module still mounted on the actuator. See p.30, level 1 maintenance, steps 1 through 6, for procedure to remove the module from the actuator. Disconnect line voltage, control signal voltage, and auxiliary switches from external power sources. More than one disconnect switch may be required to de-energize the actuator before servicing.

If only the motor capacitor is to be replaced, go directly to step 7.

1. Remove four 3/8" hex standoffs from the terminal board. Use 3/8" hex wrench.
2. Remove terminal shield and disconnect plug P2.
3. Carefully lift the terminal board straight up off the threaded ends of the control module standoffs.
4. Carefully lift the terminal board protective shield off the threaded standoffs.
5. Remove the two #6-32 x 0.312" socket head cap screws from the switch mounting plate.
6. Remove the switch assembly and disconnect the wires. Before replacing the switch assembly, reconnect the wires. Refer to Figure 11, for proper connections.
7. Cut the cable ties holding the motor capacitor to its mounts. Use wire removal tool, Beck part number 20-3600-01, to remove the two capacitor wires from the six position plug. Insert wires from replacement capacitor into the six position plug. Refer to Figure 11 for proper wire locations. Place capacitor on mounts and secure with two cable ties.

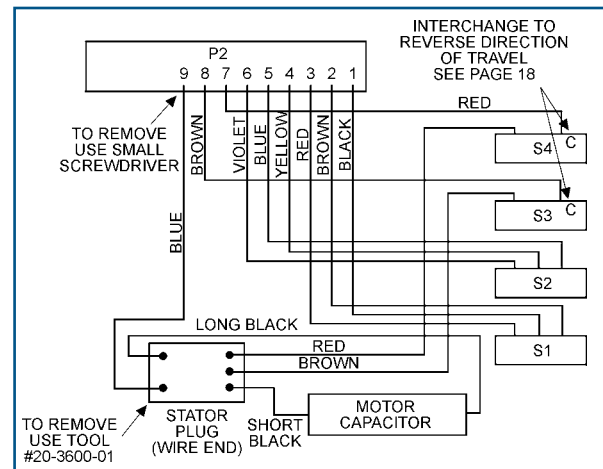

Option 1 Wiring Diagram

Figure 11

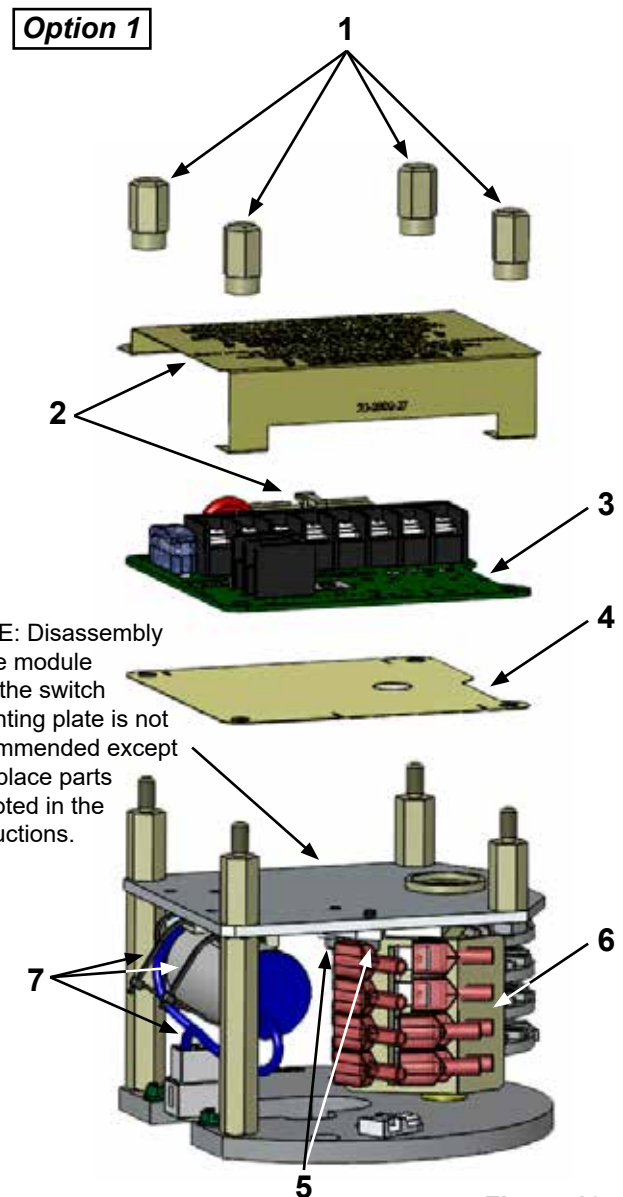
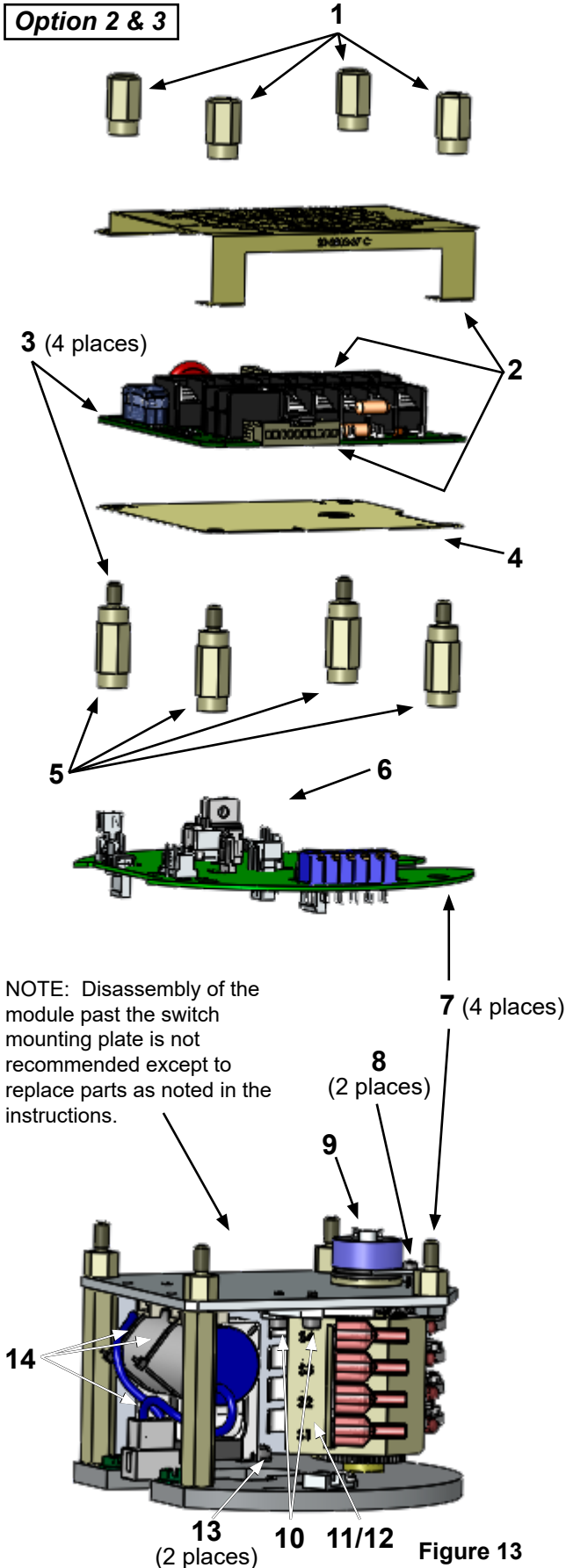

Figure 12



LEVEL 2 MAINTENANCE (Option 2 and 3 parts)

The following parts are replaceable on the Options 2 and 3 control module:

Part Name	Part Number	
	Option 2	Option 3
Terminal Board	22-5001-27	22-5001-23
Control Board	22-5001-20	22-5001-21
Switch	20-3200-14	20-3200-14
Gear, Switch Shaft	14-9940-21	14-9940-21
Motor Capacitor (60 hz)	14-2841-02	14-2841-02
Motor Capacitor (50 hz)	14-2842-23	14-2842-23
Feedback Pot.	20-3062-03	20-3062-03
Transformer	13-1810-45	13-1810-45

Refer to Figure 13 and follow the steps required to remove parts from the Options 2 and 3 control module. Reverse the steps to replace parts.



CAUTION

Do not attempt to replace control module parts with the module still mounted on the actuator. See p.30, level 1 maintenance, steps 1 through 6, for procedure to remove the module from the actuator. Disconnect line voltage, control signal voltage, and auxiliary switches from external power sources. More than one disconnect switch may be required to de-energize the actuator before servicing.

If only the motor capacitor is to be replaced, go directly to step 14.

1. Remove four 3/8" hex standoffs from the terminal boards. Use 3/8" hex wrench.
2. Remove terminal shields and disconnect plugs P1 and P2.
3. Carefully lift the terminal board straight up off the threaded ends of the control board standoffs.
4. Carefully lift the terminal board protective shield off the threaded standoffs.
5. Remove four 3/8" hex standoffs from the control board. Use 3/8" hex wrench.
6. Disconnect plugs P1, P2, P3, P4, P8, and P9 from the control board. See Figures 14 and 15, p.34 (Option 2 and 3 Wiring Diagram), for correct location to reconnect plugs.

Figure 13

MAINTENANCE

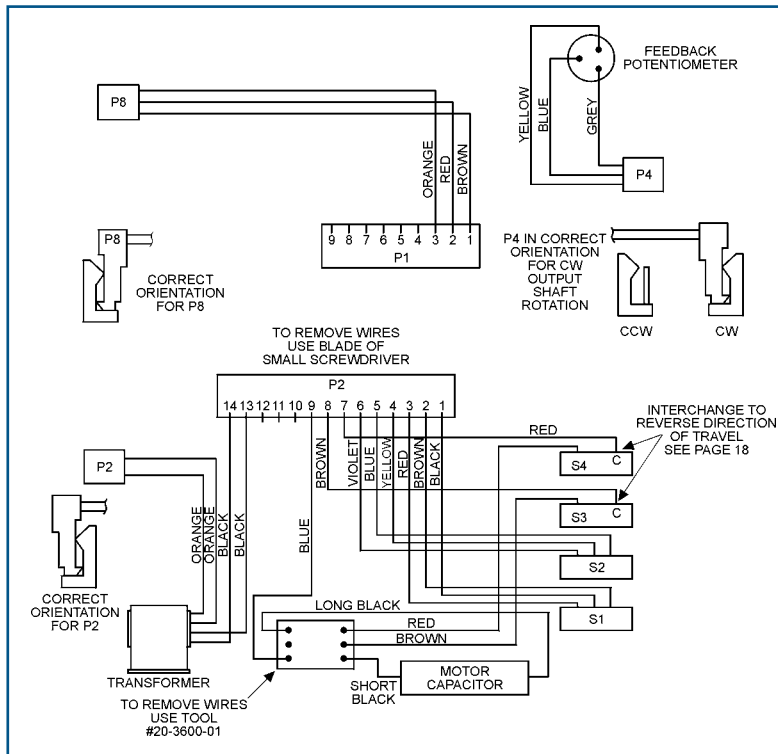

Option 2 Wiring Diagram

Figure 14

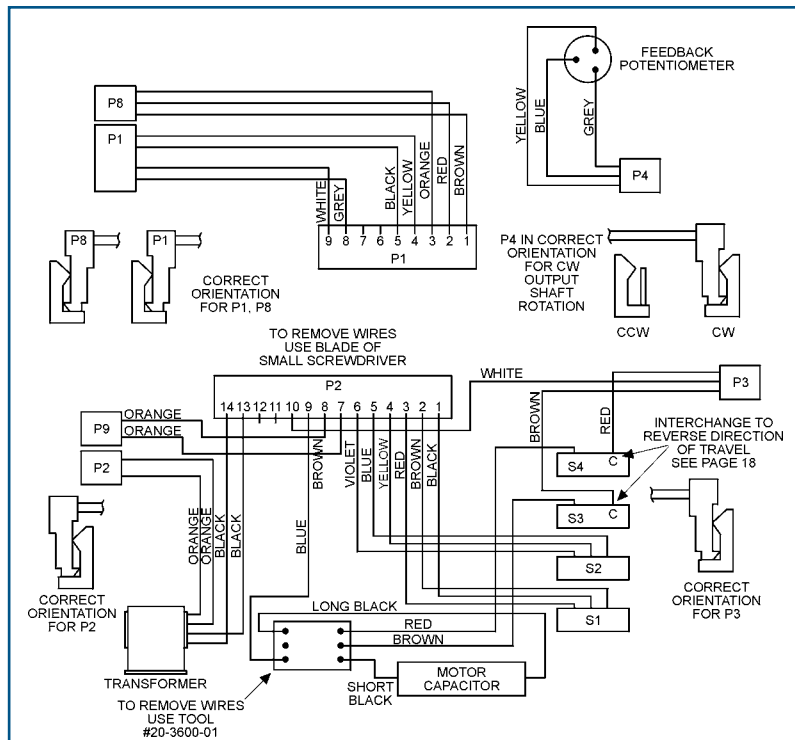

Option 3 Wiring Diagram

Figure 15

LEVEL 2 MAINTENANCE, CONT'D.

7. Carefully lift the control board straight up off the threaded ends of the control module standoffs.
If the transformer is to be replaced go directly to step 12.
8. Remove the two #4-40 x 0.312" screws and clamp that holds the feedback potentiometer to the cam and switch assembly mounting bracket.
9. Pull the potentiometer assembly straight up out of the switch shaft.
10. Remove the two #6-32 x 0.312" socket head cap screws from the switch mounting plate.
11. Remove the switch assembly and disconnect the wires. Before replacing the switch assembly, reconnect the wires. Refer to Figures 14 and 15, p.34 (Option 2 and 3 Wiring Diagram), for proper wire connections. **IMPORTANT:** Switch and transformer wires must be properly secured to the control module standoff to prevent interference with the control module cover.
12. Cut the cable tie holding the switch and transformer wires to the control module standoff. Remove the two black transformer wires from plug P2. To remove, insert the blade of a small screwdriver into the slot on the plug opposite the wire entrance. This will release a tang holding the wire termination into the plug. See Figures 14 and 15, p.34 (Option 2 and 3 Wiring Diagram), for correct location to replace wires. **IMPORTANT:** Switch and transformer wires must be properly secured to the control module standoff to prevent interference with the control module cover.
13. Remove the two #8-32 x 0.25" long screws holding the transformer to the control module base.
14. Cut the cable ties holding the motor capacitor to its mounts. Use wire removal tool, BECK part number 20-3600-01, to remove the two capacitor wires from the six position plug. Insert wires from replacement capacitor into the six position plug. Refer to Figures 14 and 15, p.34 (Option 2 and 3 Wiring Diagram), for proper wire locations. Replace capacitor on mounts and secure with two cable ties.

LEVEL 3 MAINTENANCE

Removal and replacement of output section parts.

The following parts are replaceable on the Output Section:

Part Name	Part Number
Handwheel Shear Pin	30-0314-38
Output Shaft Seal	15-1440-04
Handwheel Shaft Seal 5/16 ID	15-1440-06
Control Module Shaft Seal	15-1440-03
Output Shaft Stop Pin	30-0314-39

NOTE: Field disassembly of the output section beyond what is described below is not recommended. If the rotor is removed from the motor it will result in a loss of motor torque that can only be restored by returning the complete output section to the factory to be remagnetized.

Refer to Figure 16, p.37, and follow the steps required to remove parts from the Output Section. Reverse the steps to replace parts.



CAUTION

Disconnect line voltage, control signal voltage, and auxiliary switches from external power sources. More than one disconnect switch may be required to de-energize actuator for servicing. See p.30, level 1 maintenance, for instructions to remove the control module cover, control module and output section parts.

1. Remove the Control Module shaft seal by pushing a small blade screwdriver along the shaft and under the seal lip. Pry up the seal and force it out of the housing. **CAUTION:** The seal is only 1/8 inch (3 mm) wide. Do not force the screwdriver blade beyond the width of the seal; damage to the shaft bearing could result. Wipe the shaft and housing bore clean before replacing the seal. To replace, slide the seal over the shaft, with the closed side facing out, and press the seal into the housing.

MAINTENANCE

LEVEL 3 MAINTENANCE, CONT'D.

- To remove the Handwheel, lightly tap the shear pin out of the Handwheel and shaft using a hardened 3/32 diameter drive pin. Pull the Handwheel off the shaft.

NOTE: Support the Handwheel shaft to prevent bending.

If the Handwheel pin has sheared, pull the Handwheel off the shaft then tap the shear pin parts out of the shaft and Handwheel. Remove any burrs from the shaft. Place the Handwheel on the shaft and align the pin holes in the Handwheel with the hole in the shaft. Lightly tap the pin through the Handwheel and shaft using the 3/32 drive pin.

- Remove the Handwheel shaft seal by pushing a small blade screwdriver along the shaft and under the seal lip. Pry up on the seal and force it out of the housing. Wipe the shaft and

housing bore clean before replacing the seal. To replace, slide the seal over the shaft, with the closed side facing out, and press the seal into the housing.

- To remove the stop pin, drive the pin out of the shaft using a hardened 3/16 diameter drive pin. (The stop pin is held in the shaft with an adhesive. It may be necessary to heat the shaft to loosen the adhesive.) To replace the pin, clean the hole and bond the stop pin with an adhesive such as Loctite 640.
- Remove the output shaft seal by pushing a small blade screwdriver along the shaft and under the seal lip. Pry up on the seal and force it out of the housing. **CAUTION:** The seal is only 1/4 inch (6 mm) wide. Do not force the screwdriver blade beyond the width of the seal; damage to the shaft bearing could result. Wipe the shaft and housing bore clean before replacing the seal. To replace, slide the seal over the shaft, with the closed side facing out, and press the seal into the housing.

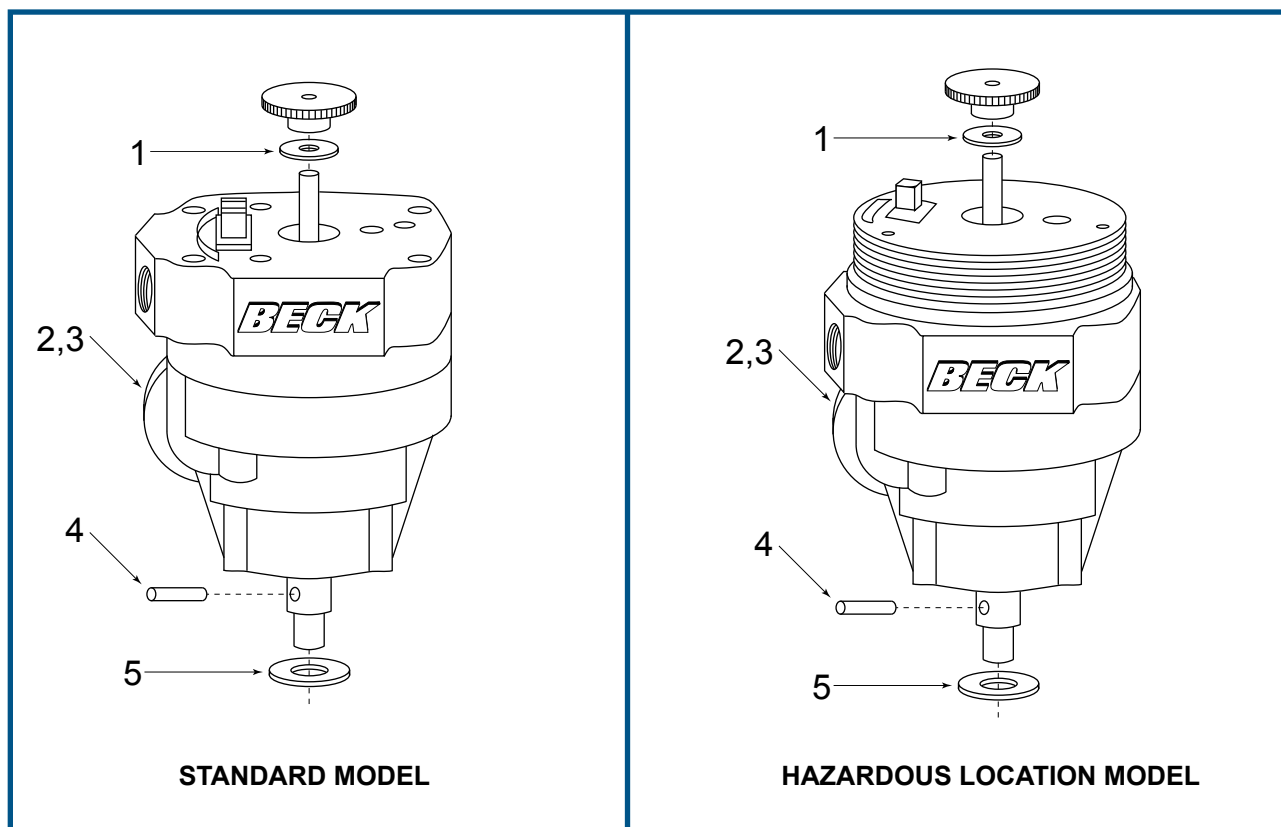

Figure 16

RECOMMENDED SPARE PARTS

It is recommended that certain replacement parts be stocked for quick availability in the event that service of your Beck actuator is required. The types of parts are listed in TABLE 4.

HOW TO ORDER SPARE PARTS

Select the needed parts from the spare parts list given below. Specify the actuator's model/serial number given on the nameplate to allow the factory to verify the part selection. Parts may be ordered by mail, telephone or fax, with the confirming order sent to the factory (see back cover).

TABLE 4: RECOMMENDED SPARE PARTS

Actuator Configuration		Control Module 60 Cycle Power (50 Cycle Power)	Cover Gasket (Standard Actuator)	"O" Ring (Explosion Proof Actuator)	Fuse
Beck Actuator Model No.	Control Option				
31-250	1	23-2102-21 (23-2102-24)	10-8080-02	14-9840-08	None
31-350	2	23-2102-22 (23-2102-25)	10-8080-02	14-9840-08	11-1370-10
31-M50	3	23-2102-23 (23-2102-26)	10-8080-02	14-9840-08	11-1370-10

COMPONENT REPLACEMENT

Table 4 lists the components of the Group 31 actuator that are field replaceable. Each of these components is available as a customer replacement kit which includes the component(s), necessary hardware and detailed instructions.



WARNING

Ignition Hazard—Do not service in locations made hazardous (classified) by the presence of combustible gases, dusts, fibers or flyings. Service should only be conducted after power has been disconnected and the area is known to be free of ignitable concentrations of combustible substances (unclassified).

INDEX

Auxiliary switches, setting.....	20	Limit switch, setting the CW switch	19
Contents	3	Linkage, installation/adjustment	15
Control options	11	Linkage kits.....	16
Control modules, option 2 (Figure 8)	25	Loss of signal, option.....	7
Control modules, option 3 (Figure 9).....	26	Loss of signal, setting/adjustment	26
Cover removal	10	Lubrication	30
Deadband adjustment	27	Maintenance, level 1.....	30
Direct coupling, installation/adjustment	14	Maintenance, level 2, option 1.....	32
Direction of travel, changing.....	20	Maintenance, level 2, options 2 and 3.....	33
Drawings, outline dimension.....	4	Maintenance, level 3.....	35
Enclosure.....	8	Mechanical stop, installation/adjustment.....	13
Exploded view, level 1 maintenance	30	Model numbers.....	8
Exploded view, level 2 maintenance, option 1.....	32	Motor	8
Exploded view, level 2 maintenance, options 2 and 3.....	33	Mounting options	5
Factory mounted assemblies.....	4	Precautions, safety.....	9
Feedback, position	7	Services, factory.....	39
Feedback, signal calibration.....	22	Services, how to obtain	39
Feedback, signal options.....	22	Spare parts, how to order.....	37
Gear train.....	8	Specifications, general	7
Handswitch, manual electric.....	8	Stall function	7, 27
Handwheel.....	8	Start-up instructions.....	17
Installation	9	Storage information	9
Introduction.....	2	Switches	8, 18
Limit switch, shaft travel adjustment.....	18	Troubleshooting.....	28
Limit switch, setting the CCW switch.....	18	Warranty statement	39
		Wiring diagrams, user connections	11
		Wiring diagram, option 1.....	32
		Wiring diagrams, options 2 and 3.....	34

LIST OF FIGURES

Outline Dimension Drawings	4
Mounting Options A & B.....	5
Mounting Options C, D & E	6
Cover Removal.....	10
Figure 1 - Terminal Wiring.....	11
Figure 2 - Mechanical Stop Kit.....	13
Figure 3 - Example of Direct Coupling	14
Figure 4 - Example of a Linkage Connection	16
Figure 5 - Switch Setting, Meter Connections.....	19
Figure 6 - Switch Common Terminals	21
Figure 7 - Option 3 Terminal Board	22
Figure 8 - Option 2 Control Board.....	25
Figure 9 - Option 3 Control Board.....	26
Figure 10 - Level 1 Maintenance, Exploded View	30
Figure 11 - Option 1 Wiring Diagram	32
Figure 12 - Level 2 Maintenance Option 1, Exploded View	32
Figure 13 - Level 2 Maintenance Option 2 & 3, Exploded View	33
Figure 14 - Option 2 Wiring Diagram	34
Figure 15 - Option 3 Wiring Diagram	34
Figure 16 - Level 3 Maintenance, Exploded View	36

LIST OF TABLES

Table 1 - Summary of Group 31 Model Numbers and Features.....	8
Table 2 - Summary of Position Feedback Options and Specifications.....	22
Table 3 - Level 1 Maintenance Replacement Parts	29
Table 4 - Recommended Spare Parts	37

SERVICES

PRODUCT DEMONSTRATIONS

Each of Beck's Sales Engineers has access to a complete set of actuator models so that he can demonstrate virtually any of their features at your location. In order to arrange to see a Beck actuator in your plant or office, contact Beck's Sales Department.

SITE SURVEYS

Beck Sales Engineers are available to discuss your process control requirements. Often a visit to your location is the best way to gain a thorough understanding of your needs, in order to meet them most accurately and completely.

Mounting hardware, torque requirements, linkage, control signal information, and optional equipment can be analyzed most effectively at the worksite. Beck's analysis at the jobsite can help ensure that specifications are accurate, especially in the case of complex applications.

APPLICATION REVIEWS

By sharing your needs with a Beck Sales Engineer you can take advantage of the best application advice for the type of control you

need. This review will yield a better understanding of the versatility of Beck actuators for your installations, as well as complete details on options and accessories to make the process as effective as possible.

SPECIFICATION WRITING

Beck provides specification writing assistance in order to help you specify and order the right actuators for your applications. Beck Sales Engineers will work with you to make it easier for you to obtain the proper equipment and give you confidence that no details are overlooked.

HOW TO OBTAIN SERVICE

Factory repair of actuators or subassemblies is available for both normal and emergency service. To assure prompt processing, contact the factory to receive a Returned Material Authorization (RMA) number. If a repair estimation is desired, please send the name and phone number of your contact for service authorization. It is helpful to include a description of the work desired with the shipment or, in the event of a problem, the malfunction being experienced.

THREE YEAR LIMITED EQUIPMENT WARRANTY

Beck warrants to Buyer that: (i) for a period of 3 years from the date of shipment, the Equipment manufactured by Beck shall materially conform to Beck's published standard specifications in effect as of the date of shipment; and (ii) the Beck Equipment will be free from defects in materials and workmanship. This warranty does not apply to normal wear and tear, or where Beck Equipment failure is a result of improper installation, improper storage, misuse or improper maintenance, or water ingress related to Buyer or its agents failing to apply the stated torque requirements to fasteners when attaching covers or failing to replace temporary conduit plugs as stated in the installation instructions, or entry through conduits.

During the Limited Warranty Period, Buyer shall notify Beck of any alleged warranty claim within 30 days from the date Buyer discovers, or upon reasonable inspection should have discovered, such alleged claim (but in any event prior to the end of the Limited Warranty Period), and Buyer shall return the Beck Equipment in question, at Buyer's expense, to Beck for evaluation, in compliance with the terms stated in the "Return of Equipment" article in the Sales Contract. If Beck determines that the Beck Equipment fails to conform to the limited warranty, then, at Beck's sole discretion and its expense (subject to Buyer's conformity with the warranty), Beck will either: (i) repair or replace the Beck Equipment, without charge, at Beck's factory, or (ii) refund the purchase price of such Beck Equipment, less any applicable discounts, rebates, or credits. In no event will Beck's liability exceed the contract price actually paid for such Beck Equipment subject to a warranty claim. Beck makes no warranty, express or implied, with respect to any Buyout Item. This limited warranty is not transferable or assignable to any transferees of the Beck Equipment.

THIS WARRANTY IS EXPRESSLY IN LIEU OF ANY OTHER EXPRESS OR IMPLIED WARRANTY, INCLUDING IMPLIED WARRANTIES OF MERCHANTABILITY AND FITNESS FOR A PARTICULAR PURPOSE, AND ALL OTHER OBLIGATIONS OR LIABILITIES OF BECK. BUYER ACKNOWLEDGES THAT: (i) BECK HAS MADE NO INDEPENDENT INVESTIGATION OF THE SUITABILITY OF THE EQUIPMENT FOR BUYER'S INTENDED USE OR EXISTING SYSTEMS; AND (ii) BUYER HAS NOT RELIED UPON ANY REPRESENTATION OR WARRANTY MADE BY BECK OR ANY OTHER PERSON ON BECK'S BEHALF, EXCEPT AS SPECIFICALLY PROVIDED IN THE SALES CONTRACT. THIS SECTION SETS FORTH BUYER'S SOLE AND EXCLUSIVE REMEDY FOR ANY BREACH OF THE LIMITED WARRANTY SET FORTH IN THIS SECTION.

A 100% EMPLOYEE OWNED COMPANY

BECK

~ founded 1936 ~

SINCE 2021



HAROLD BECK & SONS, INC.

11 TERRY DRIVE • NEWTOWN, PENNSYLVANIA 18940 • USA

PHONE: 215-968-4600 • FAX: 215-860-6383 • E-MAIL: sales@haroldbeck.com

www.haroldbeck.com

Made in USA

