



INSTRUCTION MANUAL



**This manual supports
Model 22-309 & 22-409
actuators equipped with
the 2-Wire CPS-4**



INTRODUCTION

This manual contains the information needed to install, operate, and maintain Beck Model Group 22 actuators, manufactured by Harold Beck & Sons, Inc. of Newtown, Pennsylvania.

The Group 22 actuators are powerful control packages designed to provide precise position control of dampers and other devices requiring up to 4,000 lb-ft (4 423 N•m) actuator torque.

NOTICE: This manual includes information that will make installation simple, efficient, and trouble-free. Please read and understand the appropriate sections in this manual before attempting to install or operate your actuator.



The Group 22 is an electric actuator for industrial process control. The actuator is ideal for use in large boiler applications, such as ID/FD fan dampers requiring precise, reliable control.

The Group 22 offers the excellent performance and maintenance-free design typical of Beck actuators; plus the added flexibility and features provided by microprocessor-based electronics.



Group 11 rotary actuators provide precise position control of dampers, quarter-turn valves, fluid couplings, and other devices requiring up to 1,800 lb-ft (2 440 N•m) of torque.



Group 11 quarter-turn actuators are designed specifically for use with ball, plug, and butterfly valves. Direct-coupled, factory-mounted assemblies are available from Beck for easy installation.



Group 29 linear valve actuators are ideally suited for globe valves from 1" to 8" (25 mm to 203 mm) diameter. Beck's unique Tight-Seater™ coupling provides positive seating of valves.



Group 31 compact rotary actuators are particularly suited for coupling to ball, plug, and butterfly valves up to 4" (102 mm) diameter, and small dampers.

TABLE OF CONTENTS

Introduction	2
Product Description	4
General Specifications	6
Outline Dimension Drawings	8
Precautionary Information	10
General Operation Information	11
Installation	12
Mechanical	12
Electrical	15
Wiring	16
Start-up	19
Electronics	20
Configuration/Calibration	24
Maintenance	38
Troubleshooting	46
Appendices	50
HART® Communication	50
HART® Messages	58
Serial Communication	62
Serial Commands	63
Index	70
Services	71

PRODUCT DESCRIPTION

The Beck Group 22 actuator is a family of rotary electric actuators designed for industrial process control. Group 22 actuators consist of a motor driven gear box with self-contained, microprocessor-based electronics for modulating control. This section describes the main components and their general functions.

HOUSING

Group 22 actuators have individual cast aluminum compartments for each of the five main components: motor, field wiring terminal block, gear train, digital control module (DCM-2), and control end (CPS-4 position sensor and switches). Gasketed covers and sealed shafts meet type 4X enclosure ratings suited to outdoor and high humidity environments.

Integral mechanical stops prevent accidental over-travel during manual operation.

GEAR TRAIN

The Group 22 utilizes a high-efficiency gear train designed for long life and minimal wear. The precision-cut spur gears are fabricated from heat-treated alloy steel and ductile iron.

CRANK ARM / LINKAGE

For ease of installation on any application, the heavy duty crank arm can be easily positioned to start anywhere in the full 360° rotation of the output shaft. To further facilitate proper installation and setup, the crank arm radius is easily adjustable through a wide range of values.

MOTOR

The Group 22 motor assembly is specially designed to work with the drive's on-board control electronics. The motor will not coast or over-shoot, and will not overheat, even under continuous modulation. Beck motors have double grease-sealed bearings and require no maintenance for the life of the motor. Motor overtemperature sensing is not provided by the actuator. Motor overtemperature sensing is not needed because Beck motors will not overheat.

HANDWHEEL

An easy to turn, spoke-free Handwheel is incorporated into the design of the Group 22 actuators to allow manual operation during installation or power outages. These devices can be used to precisely modulate dampers, even under full load conditions.

SELF-LOCKING MECHANISM (SLM)

An integral part of every Beck motor is the self-locking mechanism. This mechanical device couples the motor to the gear train and transmits full motor torque in either direction. When the motor is de-energized, the SLM prevents back driving of the output shaft.

HANDSWITCH

All Group 22 actuators are equipped with a Handswitch for local electrical control.

WIRING TERMINAL BLOCK

All field wiring connections are made in the terminal block compartment.

CONTROL END

The control end houses the position sensing devices including the CPS-4 (Contactless Position Sensor) and the limit switches.

The CPS-4 generates a voltage signal proportional to the output shaft position and sends the signal to the DCM-2 control board. The DCM-2 interprets the signal as the current actuator position and controls accordingly.

The control end also has four cam-operated switches. Two of these switches act as over-travel limit switches to ensure the motor cannot actuator the output shaft beyond the desired range. Two auxiliary limit switches are available for discrete position indication and interlock functions.

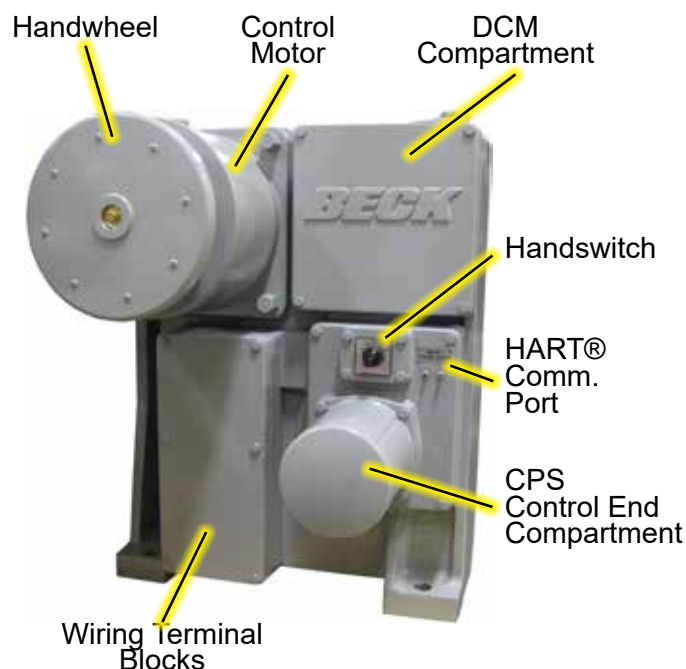

DIGITAL CONTROL MODULE (DCM-2)

Group 22 actuators are equipped with a microprocessor-based electronics assembly called the DCM-2. The DCM-2 acts as the control center for the actuator by processing inputs, generating outputs, and positioning the output shaft. The DCM-2 also contains most configuration information, maintains statistics related to actuator performance.

In Automatic mode, power to run the motor is controlled by the DCM-2 circuit board assembly. This circuit board receives a Demand signal from the external control system, interprets the signal as an intended output shaft position, then runs the motor until the output shaft matches that position.

The DCM-2 can communicate with HART networks, can receive and send analog and/or digital signals, and includes a local configuration interface. All models have an "RS 232" serial interface that can be used for configuration and diagnostics as well.

SERIAL NUMBER

Each Group 22 actuator has a nameplate fixed to the exterior of the actuator housing that includes the actuator serial number. This number uniquely identifies your specific actuator and its factory built configuration.

The format of the serial number is:

GG MMM-SSSSSS-LL-XX

e.g., 22-309-123501-01-01

where GG is the Group number

MMM is the model number

SSSSSS is the sales order number

LL is the sales order line item number

XX is the sales order sequence number

CONTROL & OPERATING FEATURES

In addition to actuator control, the microprocessor-based electronics provide a host of features and functions. Some of the advanced features include:

- Error-based variable speed operation for precise positioning performance.
- Compatible with common asset management systems.
- Two-way digital communications via HART[®] protocol and RS-232 serial connection.
- Simplified calibration without any mechanical or electrical adjustment.
- Actuator diagnostics and operating statistics available locally or remotely.
- Easy configuration, setup and documentation of actuator operating parameters.
- Live torque measurement and overtorque protection.
- Stall protection with configurable stall time setting.
- The choice of linear or square input signal characterization.
- All operating parameters including temperature can be displayed via HART.
- Configurable action on loss of Demand input signal.
- Read/write parameters including tag and descriptor information, last calibration date, and model and serial numbers are saved on board.
- Ability to restore all actuator calibration and setup information to the factory "as-built" configuration.

BECK LINKAGE KITS

Beck pipe linkage kits are available for completing the mechanical connection from the actuator crank arm to the load. Through the use of a standardized selection, the linkage can be ordered even if the exact length is not determined until the actuator and driven device are installed.

All Beck Group 22 actuators are furnished with a crank arm and rod end (see pages 8–11 for dimensions). All rod ends furnished by Beck incorporate bearings to accommodate some lateral misalignment. Once the connection is made, linkage kits can be adjusted $\pm 1 \frac{1}{2}$ " (38 mm) without removal of the crank arm or load lever, making final mechanical calibration simple.



GENERAL SPECIFICATIONS

Output Torque, Stroke Time & Weight*

Model	Output Torque lb-ft (N•m)	Stroke Timing (seconds/100°) Configurable	Weight lbs (kg)
22-309	3,000 (4 067)	30/300	515 (234)
22-409	4,000 (5 423)	15/300	515 (234)

*Weight is dependent on selected options.

Actuator Current Rating in Amps (listed by Supply Power Voltage)**

Model	Supply Voltage (Volts AC)							
	1-phase		3-phase					
	120	240	208	240	380	416	480	575
22-309	6.0	3.0	3.5	3.0	1.9	1.7	1.5	1.3
22-409	n/a	n/a	4.0	3.5	2.2	2.0	1.7	1.4

**Operating voltage tolerance is +10% to -15%. All models may be operated at 60 Hz or 50 Hz frequency. The shaded current values depict the current rating for the standard operating voltage configuration. Non-standard, 3-phase operating voltages for the 22-309 and 22-409 are available with an optional transformer.

Power Requirement for 2-Wire CPS-4

Customer must supply 24V for output shaft position feedback

Operating Conditions

-40° to 85° Celsius (-40° to 185° Fahrenheit)
0 to 100% relative humidity, non-condensing

Communication Interface

HART Protocol
Local Pushbutton / LED panel
RS-232 Serial Commands

Demand Input Signal Range

4-20 milliamps (ISA Type 4, Class U, Power Isolated)
OR 1-5 Volts DC (removal of input resistor on DCM-2 is required)

Minimum Step Size

0.1° typical

Hysteresis

0.25% of span at any point

Demand Input Signal Characterization

Linear: actuator output shaft moves proportionally to the input signal
Square: actuator output shaft moves proportionally to the square of the input signal
Square Root: actuator output shaft moves proportionally to the square root of the input signal
Special Demand Curve: actuator output shaft moves per the customer-defined Demand response curve

Position Feedback Signal

4-20 milliamps (ISA Type 2, Class U, Power Isolated), Loop-powered

Isolation

Demand input and position feedback signals are isolated from ground and the AC voltage power line. Signal buffering provides 24 volts DC isolation between the Demand and feedback signals.

Action on Loss of Power

Output shaft stays in last position.

Action on Loss of Input Signal (Power On)	Stays in place or runs to any preset position (configurable).
Overtorque Protection	If the output torque of the actuator exceeds 115% of the actuator rating, the motor will shut off (feature can be enabled/disabled).
Stall Protection	If the motor tries to run in one direction for more than 300 seconds (configurable from 30 to 300 seconds), the motor will shut off.
Over-travel Protection Switches	Two SPDT (single pole, double throw), one for CW and one for CCW limit of output shaft travel. Standard switch setting is for 101° of travel.
Auxiliary Switches (Field Adjustable)	Two SPDT (single pole, double throw), rated for 1 Amp, 250 Volts AC.
Customer Wiring	Terminals accommodate up to 12 AWG (3.31 mm ²).
Handswitch	Permits local electrical operation, independent of Demand input signal.
Handwheel	Provides manual operation without electrical power.
Motor	Does not coast or overshoot and will not overheat, even under continuous modulation.
Gear Train	High efficiency, precision-cut, heat-treated alloy steel and ductile iron spur gears enclosed in, and permanently lubricated by, a grease-filled housing are designed for long life and minimal wear.
Mechanical Stops	Prevent over-travel during automatic or manual operation.
Enclosure	Precision-machined aluminum alloy castings, painted with corrosion-resistant polyurethane paint, provide a rugged, dust-tight, weatherproof enclosure.
Mounting Orientation	Upright, as depicted in outline dimension drawings on pages 8-11.
Standards**	C-UL US Listed; CE Compliant; UKCA Compliant.

**NOTE: May not be available with all options and models. For more information, please call Beck at 215-968-4600.

OUTLINE DIMENSION DRAWINGS

MODEL 22-309 & 22-409

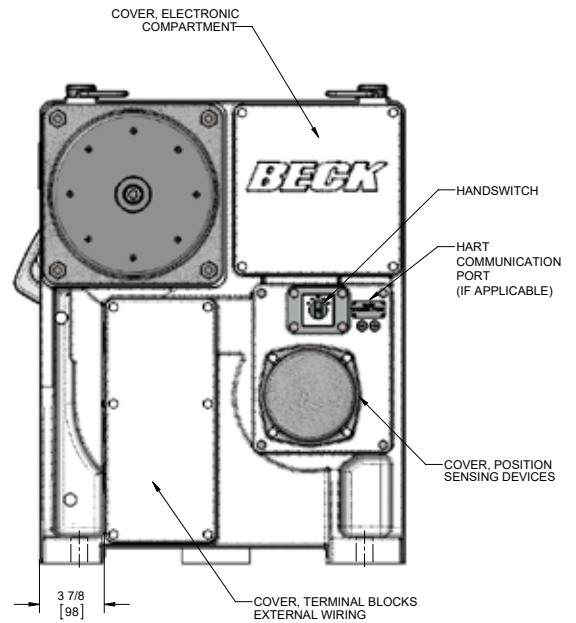
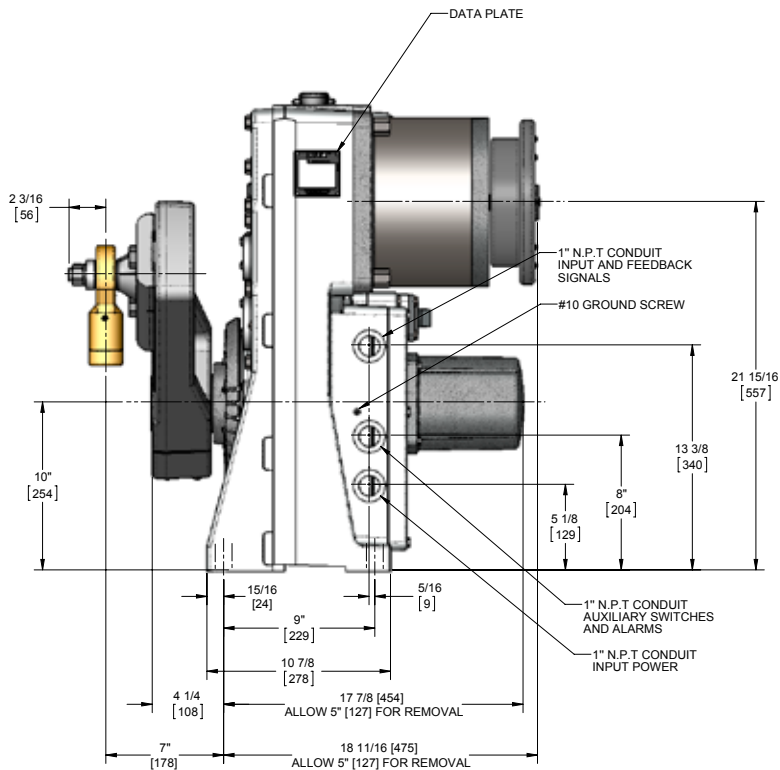

Mounting orientation should be upright for all models, as depicted

WITH OPTIONAL TRANSFORMER

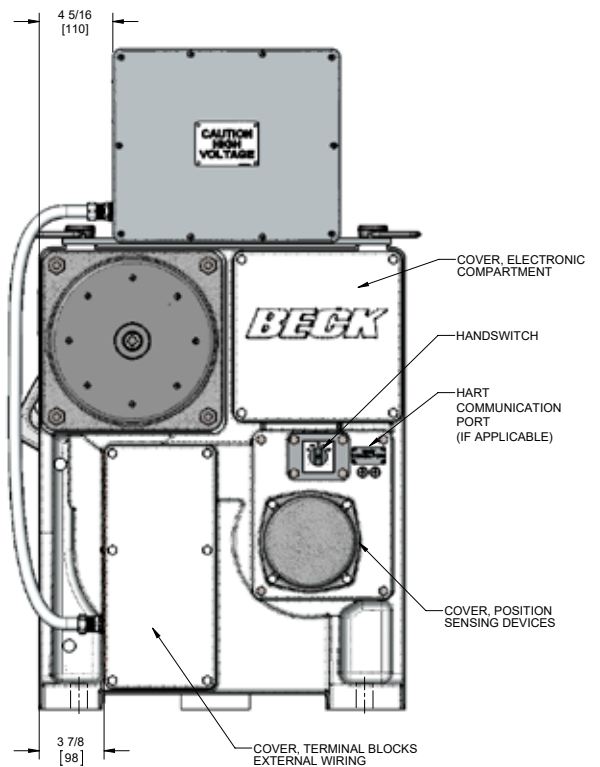
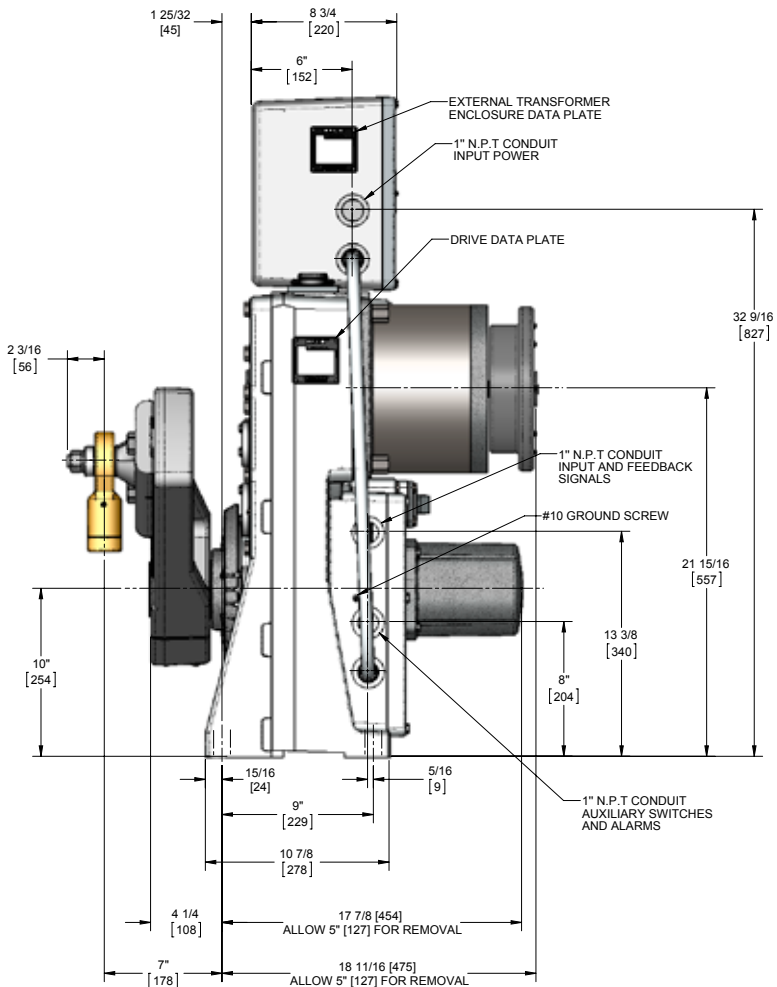

All Dimensions in Inches and [mm]

Model Number	Output Torque lb-ft [N·m]	Stroke Timing (seconds/100°) Configurable	Gear Ratio*	Net Weight lbs. [kg]	Output Shaft Diameter inches [mm]	Maximum Overhung Load lbs. [kg]
22-309	3,000 [4067]	30-300	250	540 [245]**	3-1/2 [89]	15,000 [6804]
22-409	4,000 [5423]	15-300	250	540 [245]*	3-1/2 [89]	15,000 [6804]
	2,500 [3387]	10-180	155			
	2,000 [2710]	08-150	123			

*If necessary, gear ratio may be set using Serial command "gerratio" (see page 65).

**660 lbs. [299] with optional transformer.

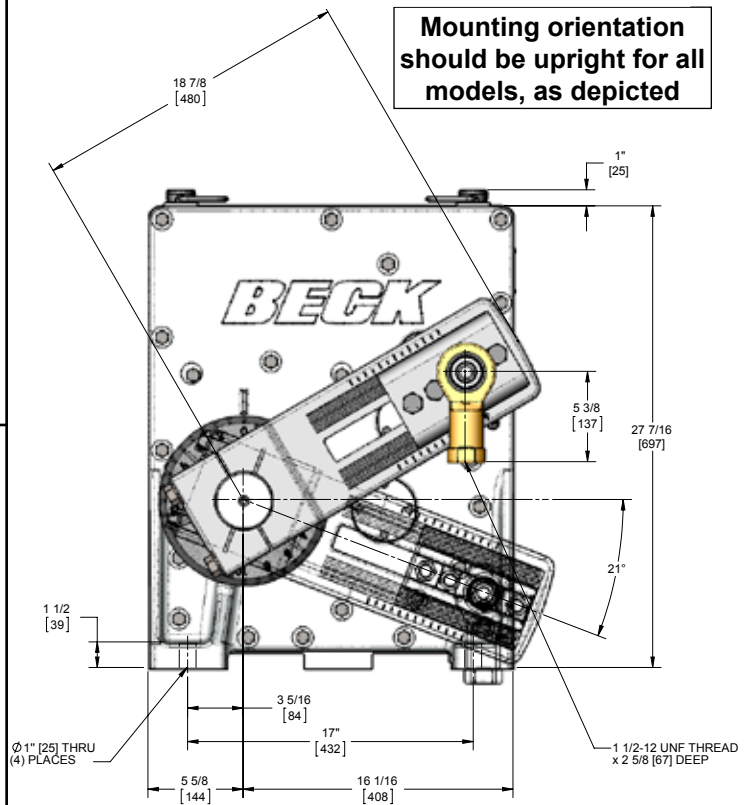
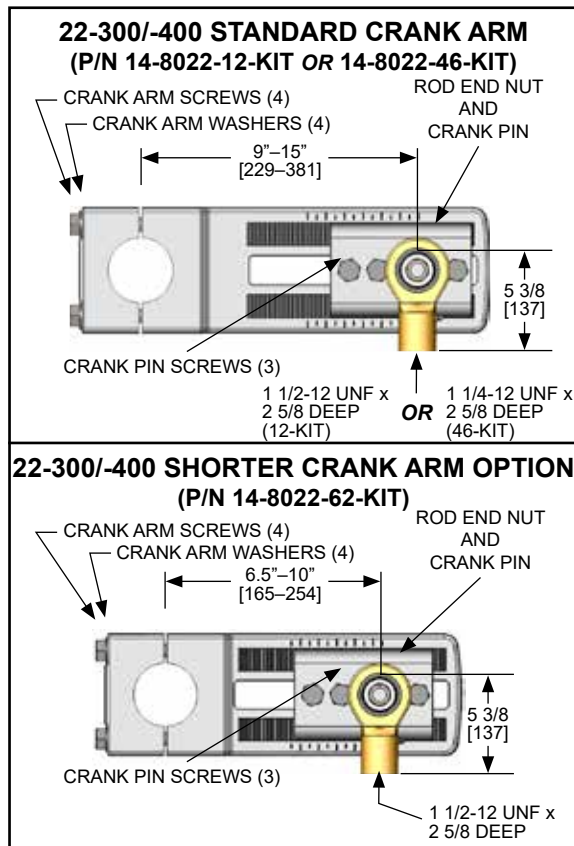

22-300/-400 CRANK ARM PARTS & FASTENER GUIDE

	Part Number	Quantity	Thread Size	Torque (lb-ft)[N·m]
Crank Arm Screw (Standard)	30-0308-13	4	3/4-16	420 [569]
Crank Arm Screw (Short, Option)	30-0308-76	4	3/4-16	420 [569]
Crank Arm Washer	30-0323-67	4	3/4	N/A
Rod End (14-8022-12-KIT)	12-2840-14	1	1 1/2-12	N/A
Rod End (14-8022-46-KIT)	12-2840-05	1	1 1/4-12	N/A
Rod End Lock Washer	30-0313-27	1	3/4	N/A
Rod End Nut	30-0319-23	1	3/4-16	200 [271]
Crank Pin	14-9885-31	1	3/4-16	N/A
Crank Pin Washer	11-7050-02	1	3/4	N/A
Crank Pin Screw	30-0307-30	3	3/4-16	300 [407]
Nut Plate	20-2641-08	1	3/4-16	N/A
Cover Screw	30-0308-98	14	5/16-18	10 [14]
Motor Mounting Nut	11-1271-10	4	1/2-13	37 [50]
Cover Screw, Optional Transformer	30-0329-70	10	10-32	3 [4]

PRECAUTIONARY INFORMATION

SAFETY PRECAUTIONS



WARNING

Installation and service instructions are for use by qualified personnel only. To avoid injury and electric shock, do not perform any servicing other than that contained in this manual.



CAUTION

Hot surfaces! Surfaces of equipment may be at an elevated temperature depending on operating conditions and environment. Allow to cool before servicing.

STORAGE INFORMATION

Beck actuators should be stored in a clean, dry area where the temperature is between -40° and 85°C (-40° to 185°F).

Group 22 actuators should be stored in an upright position and should not be stacked.

Damage due to moisture while in storage is not covered by warranty.

INSTALLATION—MECHANICAL

There are many considerations regarding proper mechanical installation—see the instructions beginning on page 12 for details. Refer to the outline dimension drawings for physical dimensions and required clearances.

INSTALLATION—ELECTRICAL

See the instructions beginning on page 15 for details regarding electrical installation.



CAUTION

For maximum safety, the Beck actuator body should be grounded. Use the green grounding screw in the wiring compartment of the actuator.



CAUTION

Always close covers immediately after installation or service to prevent moisture or other foreign matter from entering the actuator.

CONDUIT ENTRIES

Conduits are provided for power and signal wiring. Temporary plugs are installed in the conduit entrances at the factory for shipping only and are not intended for permanent use. Prior to actuator operation, all conduit entrances must be properly sealed in accordance with National Standards or Regulatory Authorities.

GENERAL OPERATION INFORMATION

MODES OF OPERATION

The Group 22 electronic actuators have four basic modes of operation as follows:

1. **Handwheel operation** - local mechanical control
2. **Handswitch operation** - local electrical control
3. **Automatic mode** - remote electrical control
4. **Override mode** - remote electrical control

Any or all of these modes can be used to test basic operation of your actuator during startup.

HANDWHEEL

Every Group 22 Beck actuator is furnished with a Handwheel to permit manual operation of the actuator with or without the supply power applied. Its solid construction design includes no spokes or projections, and turns at a safe, slow speed. The Handwheel is coupled directly to the motor shaft at the rear of the control motor housing and rotates when the motor runs.

Handwheel operation can be used at any time, but is especially useful during initial installation or when power is not available. If power is available, the Handswitch must be in the "STOP" position before manually operating the Handwheel.

Handwheel



HANDSWITCH

Handswitch operation allows local electric control at the damper. In the STOP positions, the motor is blocked from running. In the CW or CCW positions, the motor runs to move the output shaft in the corresponding direction.

When moving the output shaft using the Handswitch, the motor will stop when the over-travel limit switches are actuated.



The Handswitch is designed so that a Demand signal can operate the actuator only when the Handswitch is in the AUTO position.

AUTOMATIC MODE

When the Handswitch is placed in the AUTO position, the actuator is in automatic mode and is ready for remote electrical control. When the actuator is in AUTO it responds to a 4-20 mA control signal (also called the Demand signal or setpoint) applied to terminals 14(-) and 15(+). The electronics (DCM-2) will compare the control signal with the current output shaft position to determine if there is a difference. When the electronics detect a difference in Demand and position (called error), the motor will run and position the output shaft until the position matches the Demand.

OVERRIDE

Override operation can be used as a means of emergency operation or an alternate control method if 4-20 mA analog signalling is not available. PAT controls can be adapted by using external relays (solid state) to interface with the overrides.

Analogue signal operation may be overridden by using relay logic input signals on the control override input terminals. CW (19), CCW (20), and STOP (21) terminals require connection to a common (COM) terminal (18) to perform the override as shown in the figure below.

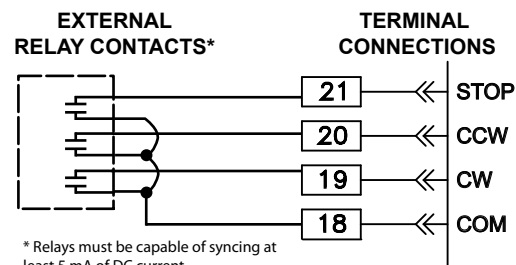

INSTALLATION Mechanical

MOUNTING THE DRIVE

Once the design installation conditions have been considered, you should mount the actuator to the mounting base.

Beck Group 22 actuators must be installed feet down. If mounting near obstructions such as pipes or beams, take into consideration access to the field wiring terminals and the output shaft. Refer to the outline dimension drawings for the clearance necessary to remove covers.

Before the actuator is bolted into place, the mounting surface must be shimmed for flatness to within 0.020 inches. Each shim must support at least 75% of the mounting foot surface area (recommended shim size is 4 square inches or larger). Improper shimming or mounting can damage mounting feet.

If the actuator is to be bolted to a mounting plate, the plate must be rigid must not yield to the stresses created from operating the actuator. If the mounting plate is not rigid or the mounting bolts are not sufficiently tightened, damage to the actuator housing could result. A rigid, vibration-free surface will generally prolong the life of the actuator's components. The mounting plate should be at least as thick as the diameter of the mounting bolts.

Mounting bolts should be 7/8"-9. The bolts should be hex head steel, zinc plated (HHSZP) Grade 5 or better. The bolts should be torqued appropriately for the application.

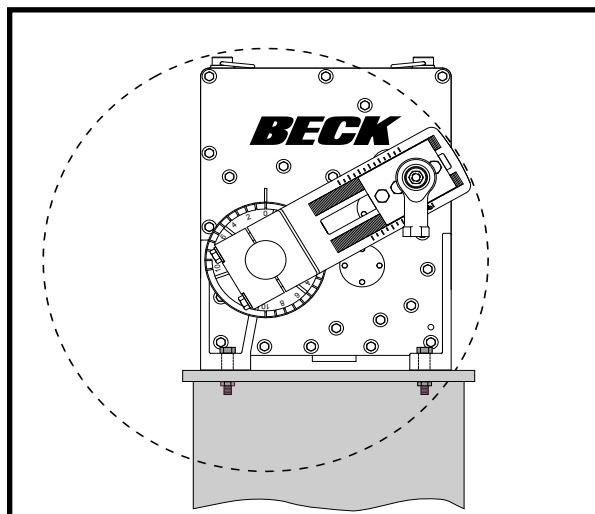

360° Crank Arm Rotation

LINKAGE REQUIREMENTS

For best results, the linkage should be designed in advance. In most applications, the best control will result when the linkage is adjusted so that the full 100° travel of the Beck actuator shaft is used, even though the driven lever may travel less than 100°. The general requirements for a good linkage are:

1. It must be rigid enough to carry the link thrust without bending or deforming.
2. It must have a built-in means of adjustment so that the length of the connecting link can be changed a small amount.
3. Rod end bearings, similar to those furnished on the Beck crank arm, should be used at both ends of the connecting link. This type of device permits small angular misalignments and helps prevent binding of the linkage.
4. The Beck crank arm radius must be calculated so that the arm will move through a 100° arc and the driven lever will move through its correct arc.
5. The actuator and driven shafts must be parallel and the linkage should be in a plane perpendicular to the shafts. See the example of a parallel linkage arrangement below.

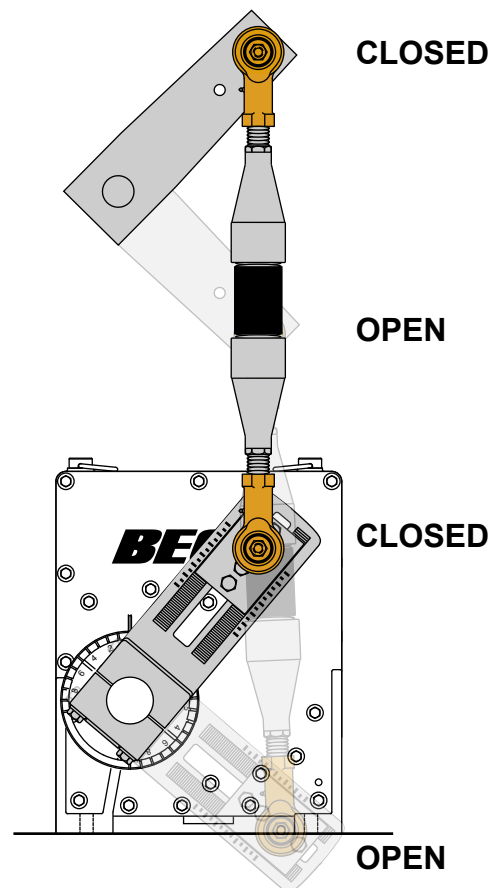

PARALLEL LINKAGE ARRANGEMENT

LINK-ASSIST™ REPORT

Contact your Beck sales engineer to obtain a Beck Link-Assist™ report specific to your application. When you provide your application's horizontal and vertical shaft offset dimensions, the damper lever arm radius, the damper lever arm start angle, and total damper lever arm travel Beck can provide the appropriate linkage length, Beck crank arm radius, and Beck crank arm start angle. For additional information regarding linkage requirements and to obtain a sample Link-Assist report, please visit the Beck website at the following address and navigate to the Link-Assist Services: <http://www.haroldbeck.com/>

The terminology mentioned above is shown in the linkage definitions diagram on page 19.

LINKAGE KITS AVAILABLE

Standard Beck linkage kits are made to accommodate a wide variation in linkage lengths without requiring modification of end fittings. This adaptability makes it possible to order, with the drive, the essential linkage end connections even though the exact linkage length may not be known until the actuator is mounted in place.

Each linkage kit includes the pipe linkage end connections (couplings), studs, lock nuts, and a rod end. Schedule 40 pipe is not included and must be cut to length and threaded in the field (see Table 1, this page, for instructions to calculate pipe length). To simplify installation of the pipe link, the kit accepts NPT right-hand threads on both ends of the pipe. Left-hand threads are internal to the linkage kit assembly, making final length adjustments quick and easy.

To order pipe linkage kits, first obtain the approximate overall linkage length "A" in the illustration below. Select the kit part number from Table 1, below. For lengths beyond those listed in the table, contact your Beck Sales Engineer.

LINKAGE KIT DETAIL

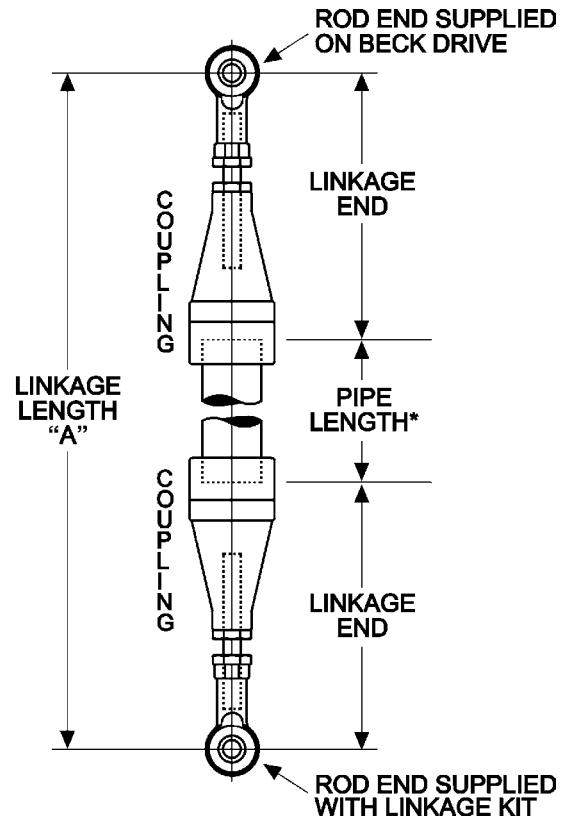

* NOTE: To calculate the length of pipe required, subtract the length of 2 linkage ends (shown in Table 1) from the linkage length "A".

TABLE 1 - PIPE LINKAGE KITS

Linkage Length "A"	Pipe Size	Minimum Pipe Nipple Length	Rod End Thread (UNF)	Linkage Kit Part No.	Length of 2 Linkage Ends (+/- 1.5" (38 mm))	Approximate Weight*
23.5"-40" (597-1 016 mm)	2" (51 mm)	2" (51 mm)	1-1/2"-12	20-1760-13	21.5" (546 mm)	28 lbs (13 kg)
37.75"-144" (959-3 658 mm)	3" (76 mm)	2.63" (67 mm)	1-1/2"-12	20-1760-10	35.13" (892 mm)	32 lbs (15 kg)
59.75"-144" (1 518-3 658 mm)	3" (76 mm)	2.63" (67 mm)	1-1/2"-12	20-1760-09**	57.13" (1 451 mm)	41 lbs (19 kg)
STAINLESS STEEL PIPE LINKAGE KITS						
23.5"-40" (597-1 016 mm)	2" (51 mm)	2" (51 mm)	1-1/2"-12	20-1760-43	21.5" (546 mm)	28 lbs (13 kg)
37.75"-144" (959-3 658 mm)	3" (76 mm)	2.63" (67 mm)	1-1/2"-12	20-1760-60	35.13" (892 mm)	32 lbs (15 kg)
59.75"-144" (1 518-3 658 mm)	3" (76 mm)	2.63" (67 mm)	1-1/2"-12	20-1760-59**	57.13" (1 451 mm)	41 lbs (19 kg)

Note: To calculate length of pipe required, subtract "Length of 2 Linkage Ends" from Linkage Length "A" (shown in diagram above).

* Does not include customer supplied pipe.

** Use when the angle between the linkage and the crank arm is less than 25°.

INSTALLATION Mechanical

LINKAGE INSTALLATION

The following procedure is recommended to couple the linkage between the Group 22 actuator and the driven shaft:

1. Position the driven shaft ① to the fully closed position.
2. Set the driven shaft lever to its required starting angle ② (predetermined with Link-Assist™).
3. Remove the rod end ③ from the Beck crank arm. Attach to the connecting link.
4. Adjust the connecting link ④ to the predetermined length.
5. Connect the connecting link to the driven lever at the predetermined radius ⑤.
6. Set the crank pin ⑥ on the Beck crank arm to the predetermined radius (see crank arm details on page 9). This is done by loosening the crank pin screws ⑦ and sliding the crank pin to the predetermined position. Tighten the crank pin screws to the appropriate torque.
7. Loosen the crank arm clamping screws ⑧.



CAUTION

The crank arm will pop free, allowing adjustment for 360° around the shaft.

8. Position the actuator's output shaft ⑨ to its fully closed limit.
9. Swing the crank arm into position and assemble the connecting link to the crank arm crank pin. Tighten the rod end nut ⑥ to the appropriate torque (see page 9).
10. Tighten the crank arm screws ⑧ evenly, in a cross-pattern, to the appropriate torque (see page 9).
11. Lubricate the rod end bearings.

Carefully move the drive's output shaft to the full forward (maximum input signal) position. Check that no binding occurs between the linkage, crank arm, driven shaft lever, and surrounding obstructions. Also observe that the driven shaft rotates the proper amount. Check that the actuator reaches the forward limit and shuts off.

If binding in the linkage occurs due to too much travel of the driven lever, travel can be reduced by shortening the Beck actuator crank arm radius. Return the actuator to the full reverse position. Loosen the crank arm crank pin screws, and the linkage stud-coupling lock nuts. While rotating the linkage (to make fine length adjustments) move the crank pin in the serrated slot to a shorter position. The crank pin may be adjusted in 1/4" increments on all Group 22 models.

22-309 / 22-409 LINKAGE INSTALLATION

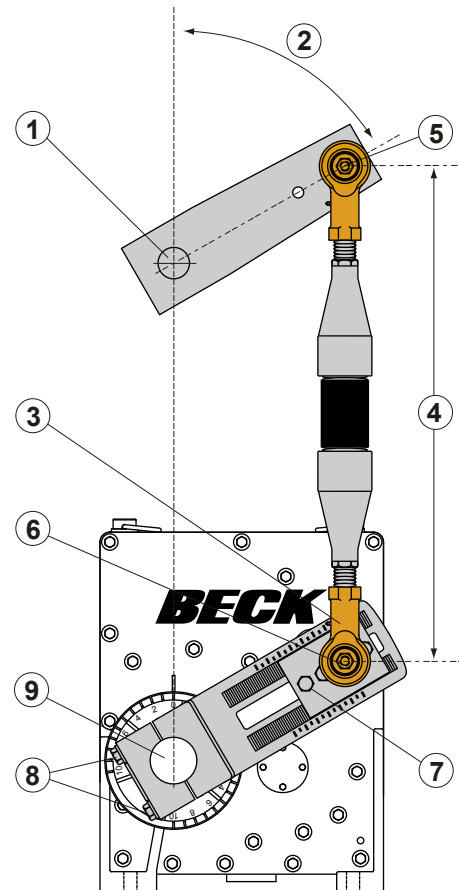

It is preferable to make linkage adjustments using the stud-coupling threads. The couplings have right-hand and left-hand threads, so it is not necessary to disconnect the ends to make a length adjustment. If necessary, the rod ends may also be adjusted.



CAUTION

The thread engagement depth in the couplings and rod ends must be greater than 1.25 x the thread diameter.

Tighten crank pin screws and linkage lock nuts, and once again, check operation to confirm that no binding occurs between the linkage and crank arm, driven lever arm, or surrounding obstructions. Further travel adjustments can be made by repeating the above steps.

Tighten all lock nuts and screws to the specified torque value.

INSTALLATION *Electrical*

POWER QUALITY

Power quality disturbances such as power outages, transient voltages, harmonic distortions, and electrical noise should be accounted for during installation of your actuator. Protecting your actuator from these conditions can reduce downtime and promote a longer lifetime for the equipment. Following the recommendations below will maximize the protection.

- ✎ Select wiring materials according to the correct ampacity ratings dictated by national and local regulations.
- ✎ Shielded, twisted pair cables can be used for signal connections to avoid being affected by electrical noise. These signal wires, based on Noise Susceptibility Level (NSL) per IEEE-518, fall into the level 1 classification. A braided shield will be more effective than a wrapped foil shield. Signal wire shields should be connected to the actuator casting grounding screw. If grounding at the signal source is required, then the shield should not be grounded at the actuator.
- ✎ Raceways such as conduits and trays have to be grounded at both ends to properly meet immunity requirements.
- ✎ An AC power ground connection should be made between the power source and the Beck actuator. Grounding connections including wire and metal conduit are permitted, except the drive-grounding conductor may not be connected to a structured metal frame of a building.
- ✎ Surge suppression equipment that meets Underwriters Laboratory (UL) Standard 1449 may be used to protect against transient voltage conditions.
- ✎ Power Conditioners may be used to regulate the supply voltage and maintain a constant voltage level. They are helpful in protection against voltage sags and swells, as well as some measure of electrical noise protection.
- ✎ Harmonic filters may be used to minimize the effects of supply voltage waveform distortions and are used in applications that incur a large amount of high-frequency electronic noise.

ELECTRICAL INSTALLATION

Three 1" N.P.T. conduit connections are provided for power and signal wiring to the actuator. One conduit is provided for signal wiring connections, and the other conduits are provided for power and auxiliary switch connections. Conduits should be routed from below the actuator so that condensation and other contaminants flow away from the conduit. All conduit entrances must be properly sealed in accordance with National Standards or Regulatory Authorities.

Power and signal wires should be routed to the actuator separately. Shielded cables are recommended, otherwise the wires should be installed in conductive conduit and/or cable trays.

Large, clearly labeled terminal blocks are enclosed in a gasketed compartment.

Refer to the wiring diagram furnished with your Beck actuator (fastened to the inside of the terminal block cover) for proper AC power and signal connections. It is advisable to provide normal short circuit protection on the AC power line.

For maximum safety, the Beck actuator body should be grounded. Separate ground terminals are provided in the wiring compartment for power and signal wiring. Wire size 12 AWG (3.31 mm²) is recommended for this purpose.

TERMINAL CONNECTIONS

The Group 22 terminal block assemblies have screw-down clamp terminals with separation barriers and nylon paper electrical shields (shields not shown on terminal connection diagrams). The terminals can accept a variety of lug types or a bare wire. Terminals will accommodate up to 12 AWG (3.31 mm²) wires, with the exception of the power terminals included with the optional transformer enclosure on the 22-309/-409 (terminals 1, 2 & 3), which will accommodate up to 10 AWG (5.26 mm²) wires.

TERMINAL SCREW TORQUES

Regardless of wire termination type, each terminal screw should be torqued to the proper specification upon landing your wire.

All input power terminal screws (terminals 1 to 3) should be tightened to 10 lb-in. The optional transformer enclosure should be tightened to 20 lb-in. All signal wiring terminal screws (terminals 4 to 21) on all Group 22 models should be tightened to 9 lb-in. Both the power and signal ground screws should be tightened to 20 lb-in.

INSTALLATION Wiring

SUPPLY POWER TERMINALS 1, 2, AND 3

Standard supply power for the model 22-309 is single-phase 120 VAC (refer to the actuator nameplate for specific rating). Input power connects line to terminal 1, neutral to terminal 2, and ground to the enclosure power ground screw. Terminal 3 is unused for 120 VAC operation.

Standard supply power for the model 22-409 is three-phase 208 VAC. Lines 1, 2, and 3 connect to terminals 1, 2, and 3 respectively on this actuator. The ground wire should be connected to the enclosure power ground screw.

Alternate voltage options include single-phase 240 VAC for the model 22-309 and three-phase 208, 240, 380, 416, 480, & 575 VAC for both Group 22 models. The Group 22 requires an optional transformer enclosure to accommodate any non-standard voltage configuration.

Group 22 actuators are equipped with a transient protector assembly installed across each, or a combination of terminals 1, 2, and 3 (dependent upon your actuator model and configuration). Note: The transient protector assembly should not be removed.

AUXILIARY LIMIT SWITCHES TERMINALS 4 THROUGH 9

Group 22 actuators include two single pole double throw (SPDT) auxiliary limit switches rated for 1 Amp at 250 VAC. These switches may be useful for discrete position indication. The limit switches are actuated by adjustable cams on the control shaft (located with the position sensing device). Details on standard factory switch settings can be found in the configuration section of this manual.

AUTO MODE INDICATION TERMINALS 10 AND 11

A dry contact is available at terminals 10 and 11 to indicate when the Handswitch is in the AUTO position. The switch contact is Form A; when the Handswitch is not in the AUTO position, the contact is open and when the Handswitch is in the AUTO position, the contact is closed. The contact is rated for 1 Amp at 250 VAC.



CAUTION

Always close covers immediately after installation or service to prevent moisture or other foreign matter from entering the actuator.

SYSTEM ALARM TERMINALS 12 AND 13

Indication of the system alarm is available as a dry contact at terminals 12 and 13. The factory standard is to open on alarm, but it may be reconfigured to close on alarm. Note that when power is lost, the contact opens. Reference the configuration section of the manual for additional details on how to change this functionality. The contact is rated for a maximum of 80 milliamps at 120 VAC/VDC.

DEMAND SIGNAL TERMINALS 14 AND 15

The DCM monitors an analog 4-20 milliamp input signal at terminals 14 (-) and 15 (+), and positions the output shaft position to match in response. The standard response is to follow the Demand signal linearly.

FEEDBACK SIGNAL TERMINALS 16 AND 17

The DCM-2 transmits a 4-20 milliamp position feedback signal on terminals 22 (-) and 24 (+) that is proportional to the actuator output shaft position.

CONTROL OVERRIDE INPUTS TERMINALS 18 THROUGH 21

Analog signal operation may be overridden by using discrete input signals on the control override input terminals. CW (19), CCW (20), and STOP (21) terminals require connection to a common (COM) terminal (18) to perform the override as shown in the table below.

Terminal Connections	Output Shaft Action
19 to 18	Clockwise Rotation
20 to 18	Counter-Clockwise Rotation
21 to 18	Stop in Current Position

The connection to terminal 18 is designed to be made through relay contacts or through a solid state switch capable of sinking at least 5 milliamps DC. When the circuit is open, terminals 19, 20, and 21 should measure +12 VDC with respect to terminal 18.



CAUTION

Do not connect an external voltage source to override terminals 18–21; an external voltage source may damage the DCM circuitry.

**MODEL 22-309 & 22-409
TERMINAL CONNECTIONS**

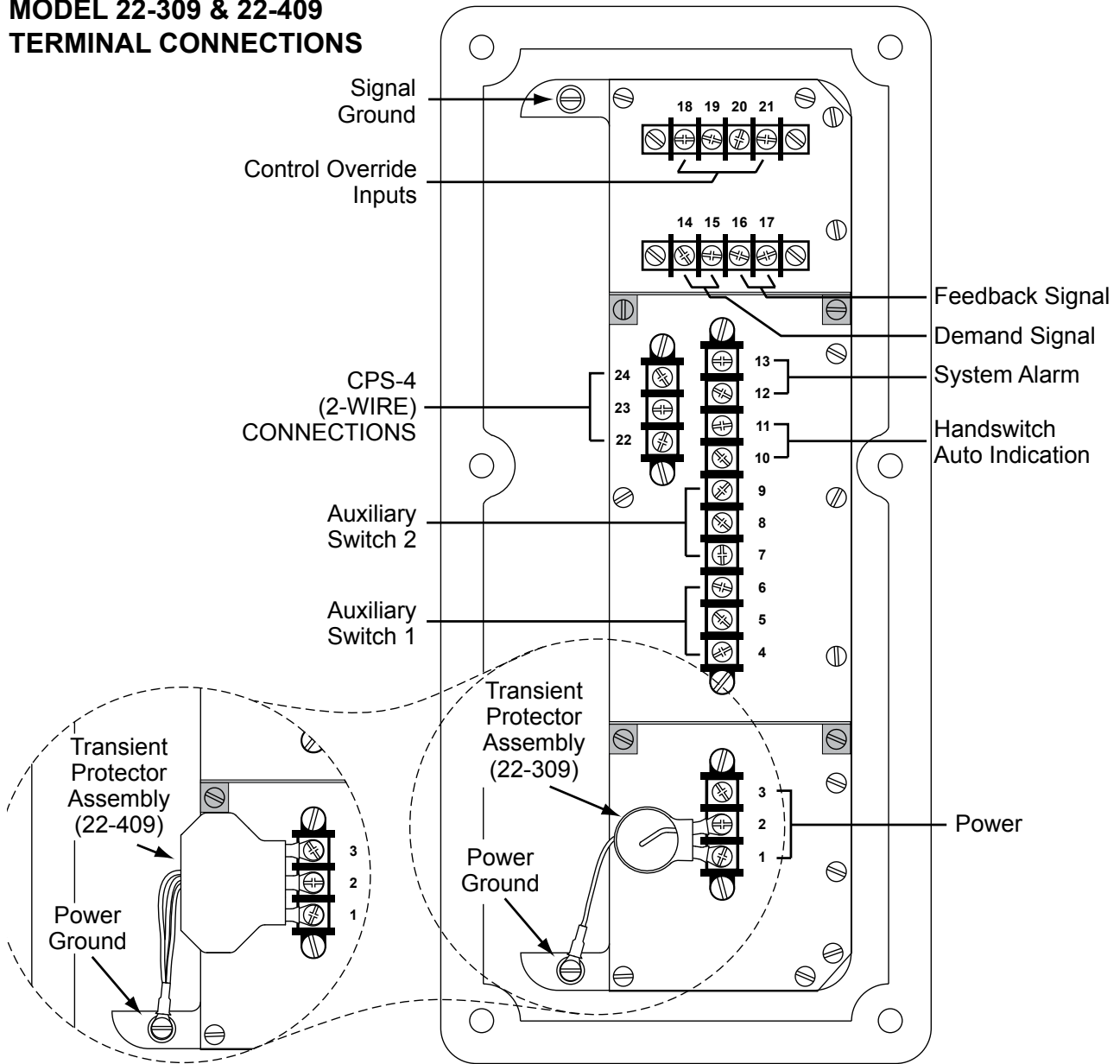

**OPTIONAL
TRANSFORMER
ENCLOSURE POWER
CONNECTIONS
FOR MODELS 22-309 / 22-409**

(Refer to page 39 for replacement fuse part numbers)

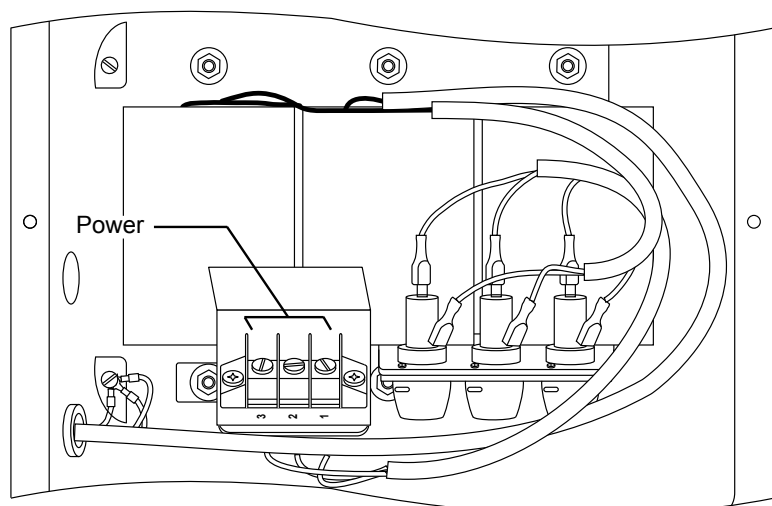

OPTIONAL ENCLOSURE

INSTALLATION Wiring

22-309

Typical Schematic

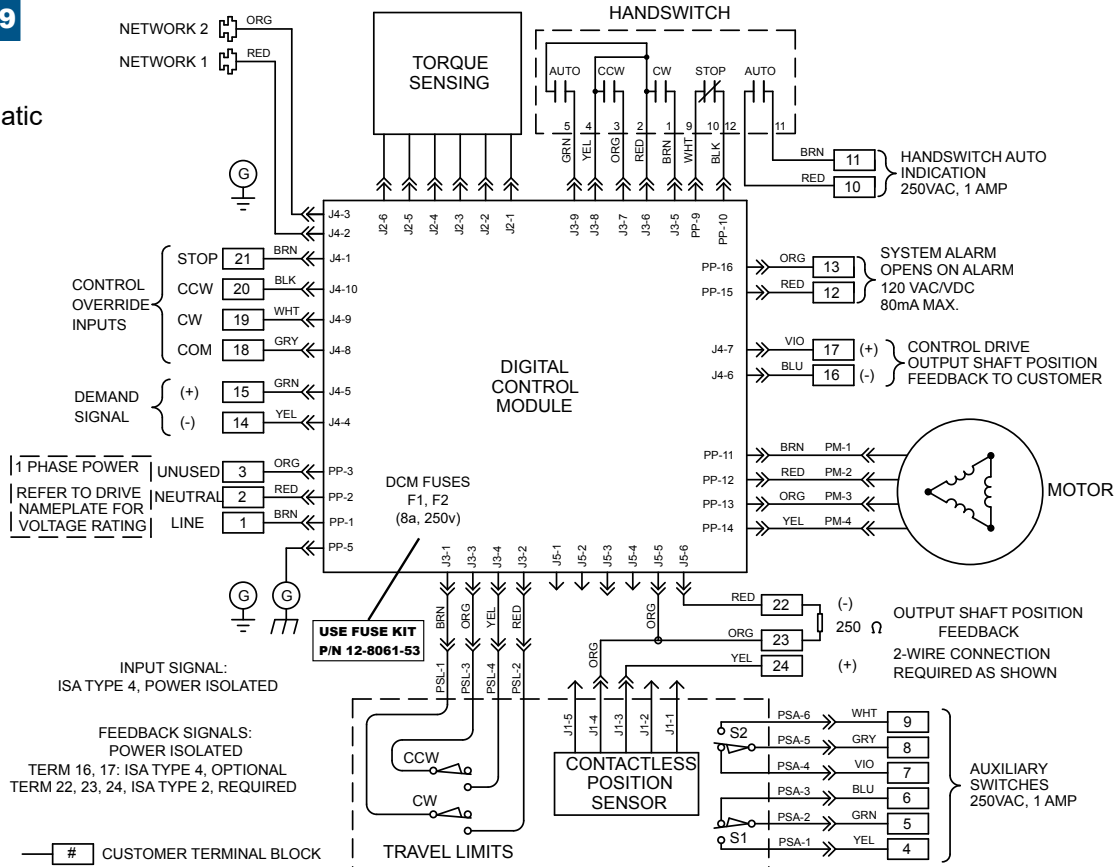

22-409

Typical Schematic

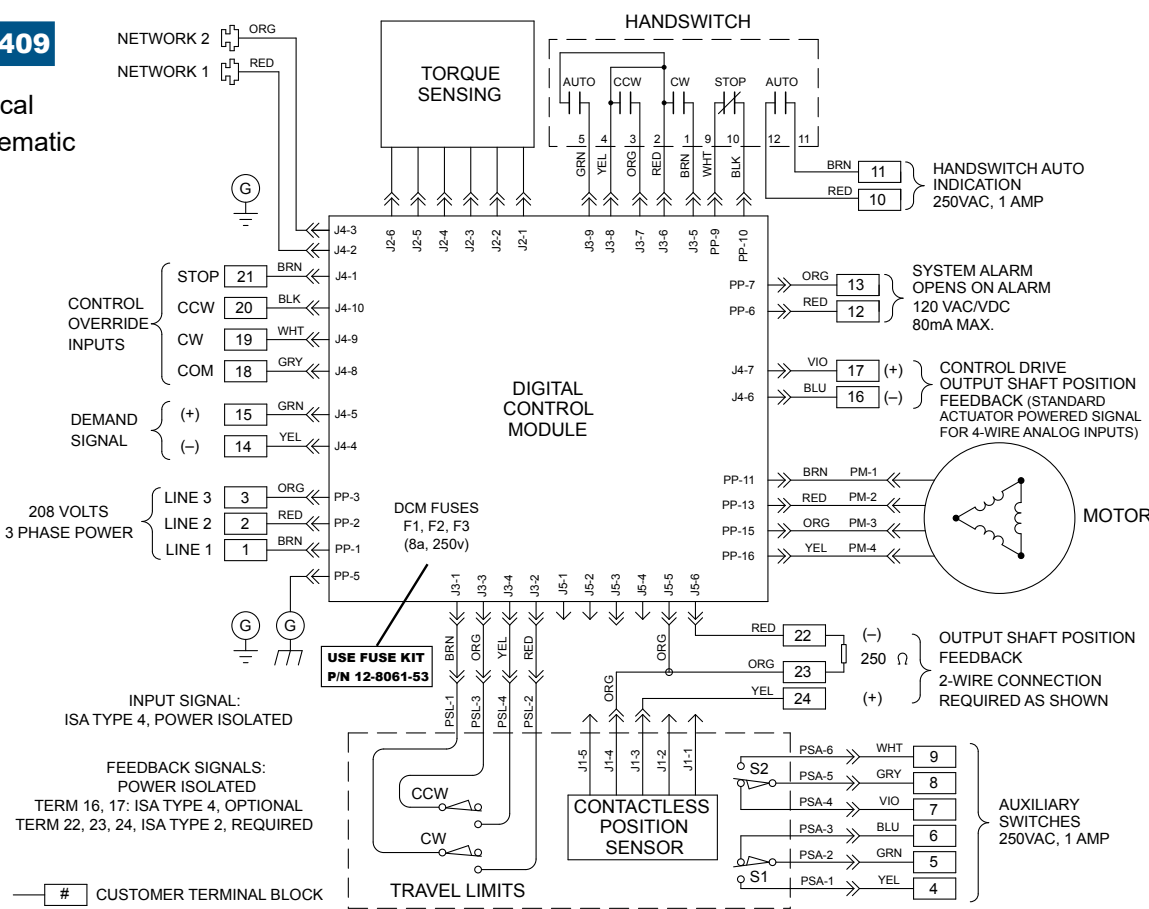

START-UP

STARTUP

NOTE: All Beck actuators are shipped from the factory ready for installation. Each actuator is set up and calibrated to the customer's specifications that were written into the equipment order. Electrical adjustments are generally not required before placing the actuator in operation.

STARTUP CHECKLIST

The following list provides some basic checks that should be performed before placing your actuator into operation. These steps should be performed prior to linkage installation. If your linkage is installed, it is recommended that you unfasten the rod end connection from the actuator crank pin prior to taking the steps on this list.

- Inspect the mounting method and the hold-down bolts. Be sure the actuator is securely fastened to its mounting base.
- For increased personal safety on the first start-up, place the Handswitch in a STOP position. Make certain no movement of the output shaft and linkage can cause personal injury.
- Confirm the actuator is receiving the appropriate operating voltage as shown on the nameplate.
- Check the DCM-2 Power LED. It should be pulsing (Dim/Bright) to indicate the board is active.
- Using the Handswitch, confirm the actuator moves fully to both the CW and CCW ends of travel.
- Confirm the actuator has a 4-20 mA Demand signal on terminals 14 and 15. You can check for 1-5 VDC across terminals 14 and 15 as an alternate means of verifying the Demand signal.
- Place the Handswitch in AUTO and vary your control signal from 0% to 100%.
- Check for any of the status alarm LED's on the DCM-2 local interface panel. If any are lit refer to the troubleshooting section of this manual for corrective action.
- Verify that the output shaft is moving to the desired 0% position with a 0% Demand signal and moving to the 100% position with a 100% Demand signal. If they are reversed, see the calibration section of this manual for directions on how to change the direction of output shaft rotation.

ELECTRONICS

DIGITAL CONTROL MODULE (DCM-2)

The DCM-2 is a micro-processor based circuit board assembly that serves as the actuator's control center. The DCM-2 chassis assembly is comprised of a Control circuit board, a Driver circuit board (inverter circuit), additional circuit components like capacitors and transformers, and an aluminum chassis to which both the boards and the components are fastened. The whole assembly is mounted in the actuator's DCM compartment (see photo).

The main function of the DCM-2 chassis assembly is to be the actuator's positioner. The control board compares the Demand input signal to the actuator shaft position feedback signal from the Contactless Position Sensor (CPS-4) located in the control end compartment (see photo).

See the troubleshooting section of this manual for details regarding the fuse locations, the test point locations, and expected test point voltage levels.

INTERFACES

The DCM-2 has three configuration interfaces: a local pushbutton interface, a HART interface, and a serial port interface.

PUSHBUTTONS

The local pushbutton interface is integral to the DCM-2 assembly. It requires no additional equipment to perform calibration procedures, but is limited in functionality. This interface also has LEDs for diagnostic information.

HART

The HART interface may be accessed by a HART handheld communicator* or a HART equipped control system. All electronic calibration, configuration, and diagnostics can be accomplished through HART communications.

SERIAL PORT

The serial port interface is accessible by connecting a computer to the DCM-2 using a Beck serial cable**. All electronic calibration and configuration can be accomplished through the serial port interface.

DCM
Compartment



Control End
Compartment

The DCM-2 chassis assembly is mounted in a dedicated compartment (see photo) and normally does not need to be removed.

Accessing the DCM-2 assembly may be required for configuration or diagnostic purposes using either the pushbutton or serial port interfaces.

If the DCM-2 needs to be repaired for any reason, the whole chassis should be removed and replaced as an assembly. See the Maintenance section of this manual for complete details on chassis removal and installation.

* See the HART appendix for details on connecting via HART communicators.

** See the serial port appendix for details on connecting via the serial port.

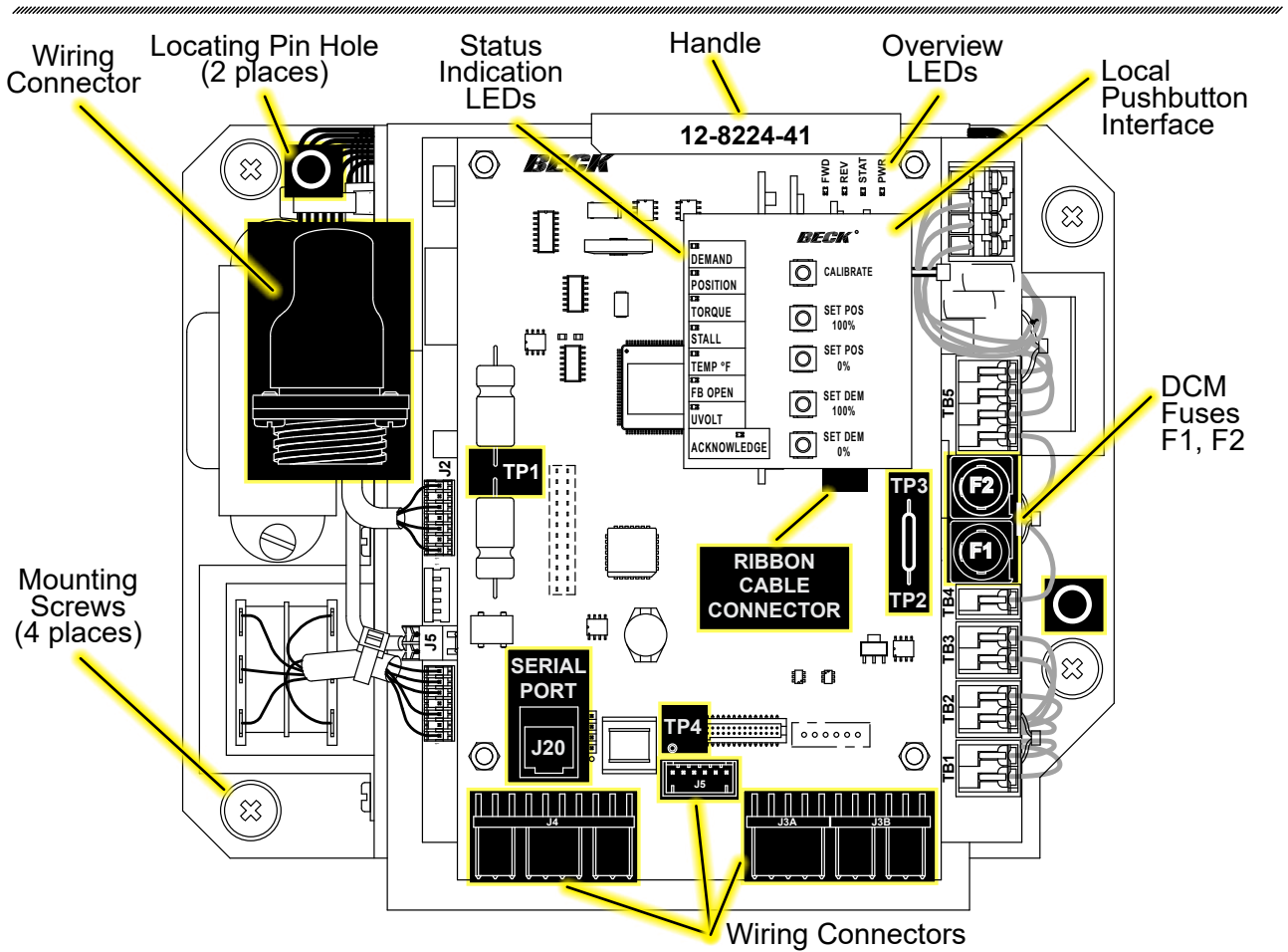

MODEL 22-309 DIGITAL CONTROL MODULE (P/N 12-8224-41)

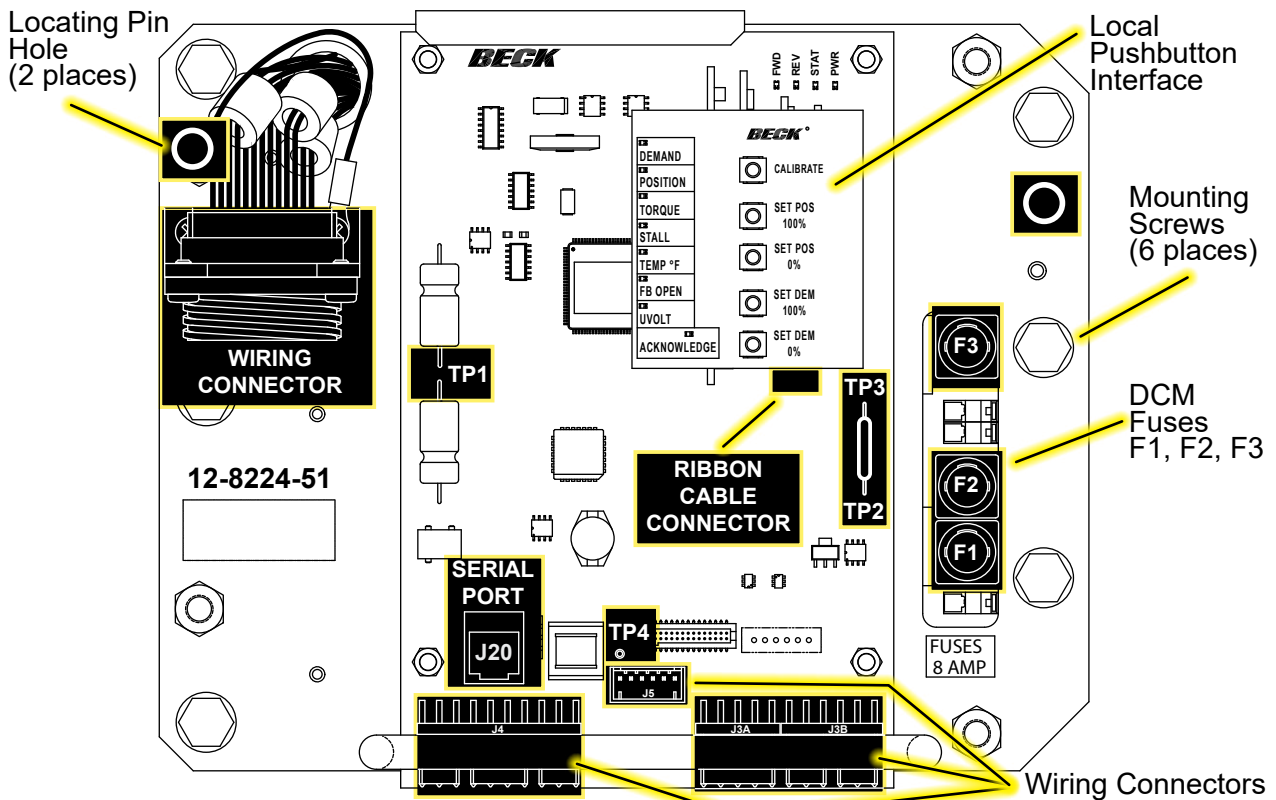

MODEL 22-409 DIGITAL CONTROL MODULE (P/N 12-8224-51)

ELECTRONICS

OVERVIEW LEDs

There are four LEDs in the upper right corner of the DCM-2 circuit board. These provide an overview of DCM-2 status.

PWR

This LED is lit when power is applied to the actuator. After initial power up, this LED pulses from bright to dim indicating the micro-processor is operating.

STAT

This LED is lit when a system alarm occurs. When the STAT LED is lit, typically a status indication LED will be illuminate to further explain the status.

REV

This LED is lit when the actuator is instructed to move in the reverse direction. The instructions may come from a Demand signal, a control override input, the Handswitch, HART, or serial commands.

FWD

This LED is lit when the actuator is instructed to move in the forward direction. The instructions may come from a Demand signal, a control override input, the Handswitch, HART, or serial commands.

OVERVIEW LEDs



STATUS INDICATION LEDs

PUSHBUTTON CONTROLS

STATUS INDICATION LEDs

The status indication LEDs are located on the left side of the local pushbutton interface.

The applicable status indication LED(s) will illuminate when the "STAT" LED is lit, to reveal the condition(s) as described below. When more than one status LED is required at one time, the illuminated LEDs will cycle rather than illuminate all at once.

Refer to the troubleshooting section of this manual for corrective actions that will eliminate system alarms, status indication LEDs from being lit, and the STAT LED from being lit.

DEMAND

The Demand signal is outside of the acceptable range of values.

(Standard current range is 3.2 - 21.0 mA DC)

POSITION

The internal position signal from the CPS-4 is outside of the acceptable range of values.

(Standard voltage is 1.0 - 5.0 volts DC)

TORQUE

The torque sensed at the output shaft of the actuator exceeds the torque alarm threshold.

(Standard torque alarm threshold is 105%)

STALL

The actuator is in a stall condition and stall protection has been activated.

TEMP °F

The temperature sensed at the DCM-2 is outside of the acceptable range.

(Acceptable range is -40°F to 185°F (-40°C to 85°C))

FB OPEN

The feedback current loop is disconnected, open, or does not sense a load.

UVOLT

The operating voltage is below the rated voltage tolerance (under voltage condition).

This LED could also be lit if an individual phase of a three-phase operating voltage is lost.

ACKNOWLEDGE

Temporarily lit when a pushbutton configuration operation is performed to confirm that the pushbutton configuration operation has been completed.

When a status LED is lit the system alarm contact will change state. Indication of the system alarm is available as a dry contact at terminals 12 and 13. The standard factory setting is for the contact to be closed in the normal state and open in an alarm state.

LOCAL PUSHBUTTON INTERFACE

The five pushbuttons located on the local pushbutton interface are used for simple calibration features. To utilize the pushbuttons, the user must press and hold the calibrate button, then press and hold the button for the desired function. Pressure should be maintained until the "ACKNOWLEDGE" LED lights; this confirms receipt of the pushbutton command. See the calibration section of this manual for further explanation of the calibration procedures.



CAUTION

Pressing the following buttons may change calibration and cause the actuator to reposition.

CALIBRATE

As a safety feature, this button must be pressed and held simultaneously with another pushbutton to perform a calibration.

SET POS 100%

Calibrates the DCM-2 to recognize the current output shaft position as the 100% position.

SET POS 0%

Calibrates the DCM-2 to recognize the current output shaft position as the 0% position.

SET DEM 100%

Calibrates the DCM-2 to recognize the currently applied Demand signal as the 100% Demand signal.

SET DEM 0%

Calibrates the DCM-2 to recognize the currently applied Demand signal as the 0% Demand signal.

CONTROL END

The control end assembly is comprised of the Contactless Position Sensor (CPS-4), limit switches, and limit switch cams (see page 20 for location).

The assembly is installed on the control shaft which is geared into the main output shaft of the actuator. As the output shaft turns it moves the control shaft, the limit switch cams, and the Contactless Position Sensor ferrite core.

The control end includes two SPDT auxiliary limit switches (labeled S1 and S2) for customer connection and two over-travel limit switches (labeled CW and CCW). The cams can be adjusted to actuate the auxiliary switches anywhere in the actuator's range of travel.

CONTACTLESS POSITION SENSOR (CPS-4), 2-Wire

The CPS-4 is a circuit board and sensor assembly that is part of the control end assembly. The CPS-4 provides the DCM-2 with a continuous position signal proportional to the position of the actuator's output shaft. Two versions of the CPS-4 have shipped with Group 22 actuators (see below).

The position sensing function of the CPS-4 is provided by a ferrite magnetic sensing element. An electronic circuit translates the voltage from the ferrite magnetic sensor into a position signal. The position signal is used by the DCM-2 to determine the actuator's output shaft position for control and to generate an analog 4-20 milliamp position feedback signal for external use.

CONTROL END / CPS-4 (BOTH VERSIONS SHOWN)

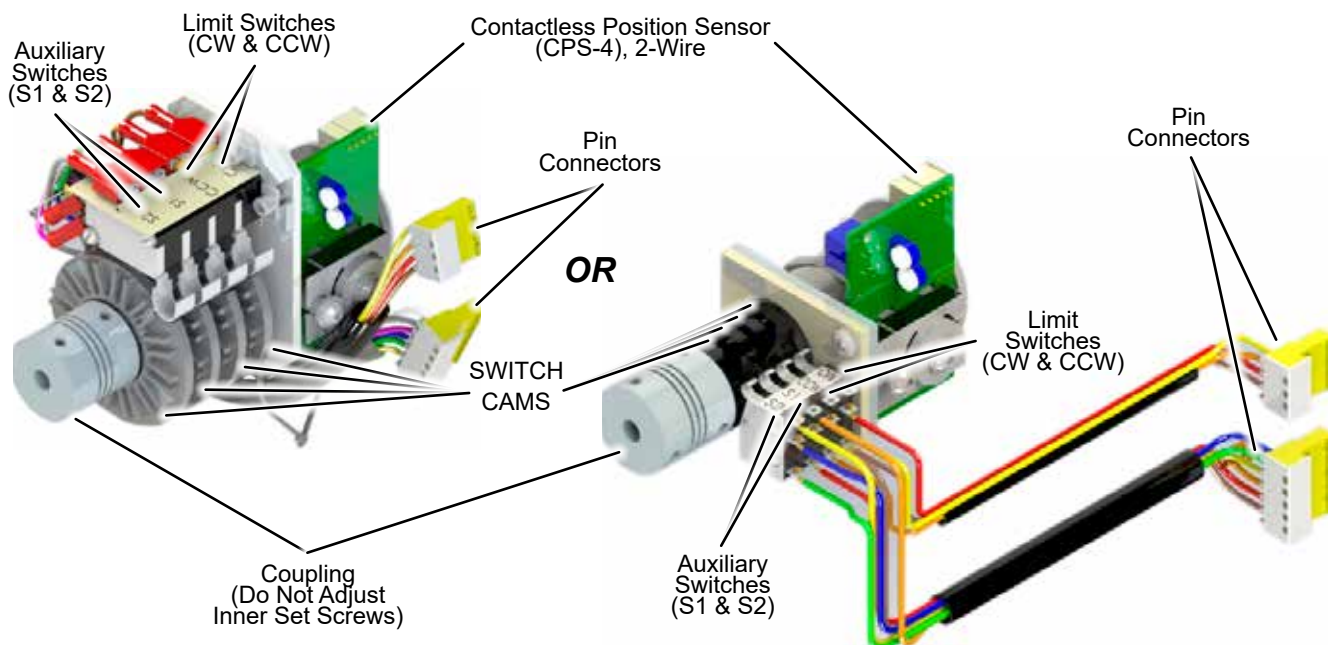

CONFIGURATION / CALIBRATION

NOTE: Your Beck actuator was shipped from the factory ready for installation; no electrical adjustments are required before placing it in operation. Each actuator is set up and calibrated to the customer's specifications that were written into the equipment order.

LIMIT SWITCHES

All Group 22 actuators are shipped with over-travel protection switches (CW & CCW) factory-set for 101° of travel unless otherwise specified at time of order. The switches must be set inside the range of the built-in mechanical stops which are approximately 106° apart. The switches can be reset to limit travel of the output shaft to any angle down to a minimum of approximately 60°. Auxiliary switches are factory set, as shown in the Auxiliary Limit Switch Settings on page 25, unless otherwise specified at time of order.

Switches are operated by cams which are clamped onto the control shaft. Setting a switch involves loosening the thumb nut, moving the drive's output shaft to the desired position, and positioning the cam so that it operates the switch at that point. In the following procedure, the use of a continuity meter is recommended to determine when the switch opens or closes. If such a meter is not available, it is possible to hear the switch click as the contacts open and close.



CAUTION

Do not attach the meter or attempt to adjust the switch cams until the actuator is disconnected from the line voltage and auxiliary switches are disconnected from external power sources.

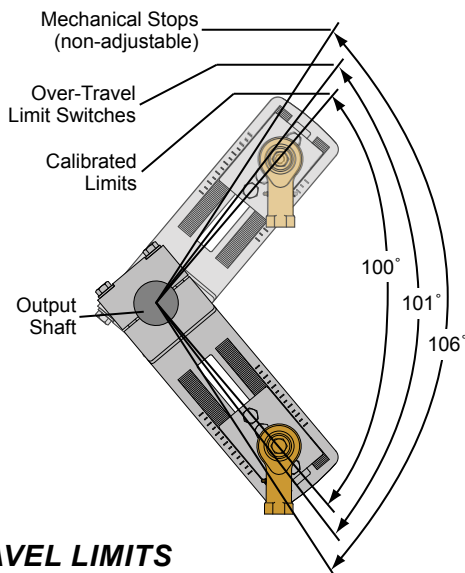

SETTING OVER-TRAVEL SWITCHES CW & CCW

This procedure should be used if the factory over-travel switch settings must be changed in the field. It is advisable to operate the actuator fully in each direction—using the Handswitch and Handwheel—to check switch settings before attempting to change them. Use the following instructions if they require adjustment:

1. Remove the control end cover and terminal block cover (1/2" bolt heads).
2. Move the output shaft to the CW or CCW limit.
3. Turn the Handswitch to the "STOP" position.
4. Use the Handwheel to position the output shaft at the desired over-travel limit.
5. **Disconnect power from the actuator.**
6. Connect a continuity meter across the appropriate pins of the J3 connector on the DCM-2 board (pins 1 & 2 for CW switch, pins 3 & 4 for the CCW switch). See Figure 2 below and the wiring diagram on the underside of the terminal block cover.
7. While holding the shaft coupling stationary, rotate the appropriate cam using the 3/32" hex wrench in one of the cam adjustment slots (see illustration on page 25) until the meter shows continuity (switch contacts closed, switch clicks).
8. Use the Handwheel and confirm that the contacts are open in the normal operating range and closed at the desired over-travel limit.
9. Disconnect the meter and reconnect actuator power.
10. Repeat instructions for setting (and verifying) the opposite over-travel protection switch.
11. Replace covers and tighten cover bolts to 10 lb-ft [14 N•m] torque.

FIGURE 2.
DCM-2 CONTROL BOARD CONNECTOR J3

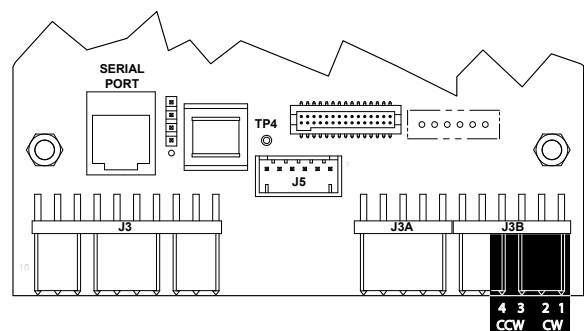

SETTING AUXILIARY LIMIT SWITCHES S1 & S2

Standard switch settings for the two auxiliary switches are shown on the Auxiliary Limit Switch Settings diagram (right). The heavy line indicates a closed circuit. Use the following instructions to change the operating point of auxiliary switches:

NOTE: In the following procedure, it is assumed that switch settings are to be adjusted so that contacts are open when the desired position is achieved.

1. Remove the control end cover and the terminal block cover (1/2" wrench).
2. Move the output shaft to the desired switch trip position.
3. Turn the Handswitch to the "STOP" position.
4. **Disconnect power from the actuator and switch terminals.**
5. Connect the continuity meter across the appropriate terminals. See the actuator wiring diagram under the terminal block cover (or the diagram at right).
6. Rotate the appropriate cam using the 3/32" hex wrench in one of the cam adjustment slots (see below) until the meter shows continuity (switch contacts closed, switch clicks).
7. Disconnect the meter and reconnect power.
8. Move the output shaft in the desired direction to verify that the cam lobe moves away from the switch lever. If not correct, return to step 2 and reset the cam to the proper orientation.
9. Replace covers and tighten cover bolts to 10 lb-ft (14 N•m) torque.

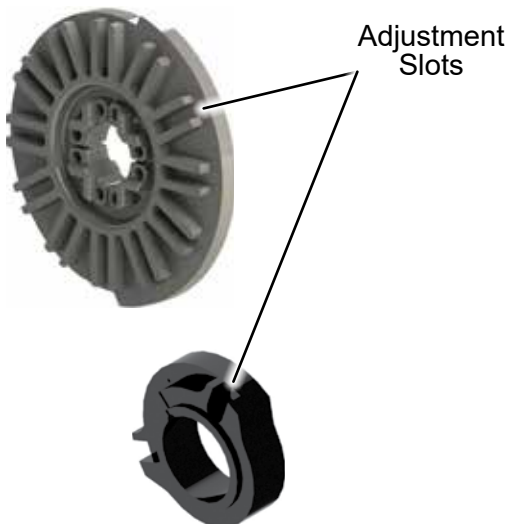

LIMIT SWITCH CAM DETAIL (both versions)

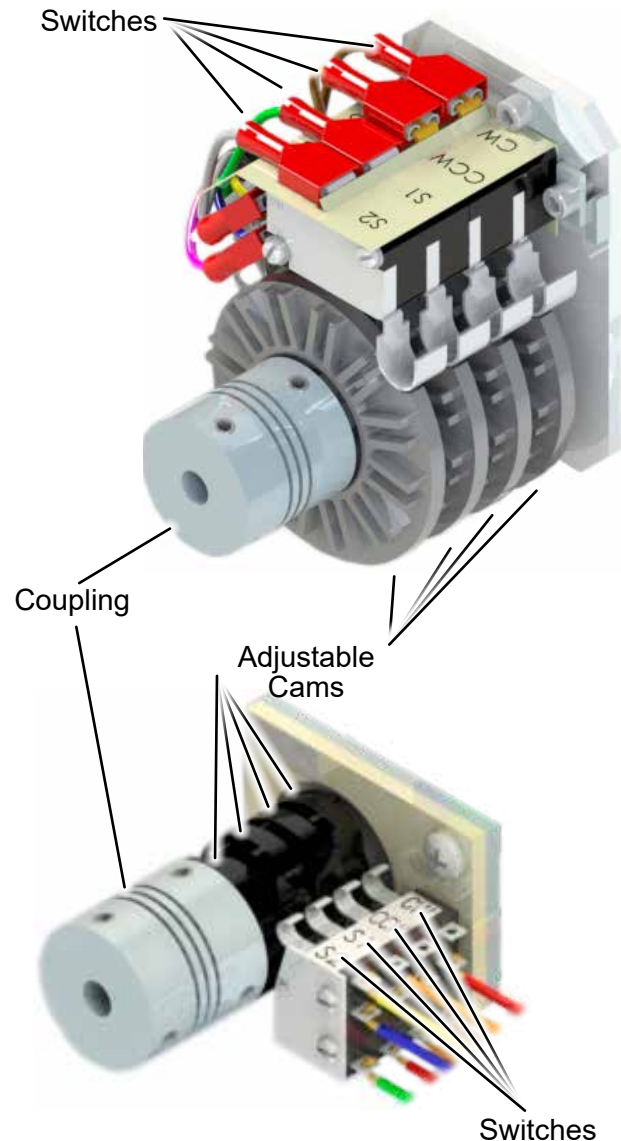
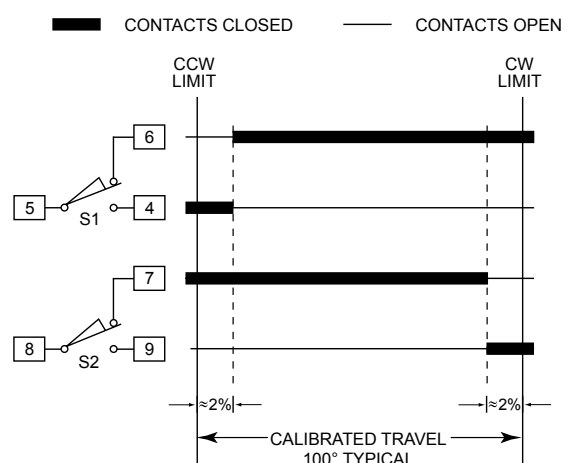

FIGURE 3.



Note: The switch contacts are shown at midpoint of travel.

CONFIGURATION / CALIBRATION

ROTATION DIRECTION

Rotation direction refers to the direction the output shaft of the actuator rotates in response to an increasing Demand input signal. The rotation is either clockwise (CW) or counterclockwise (CCW) as shown in the figure below. The rotation of the driven load (i.e. damper lever arm) determines the actuator rotation suitable for an application.

Unless otherwise specified at the time of the order, Group 22 actuators are set for CW rotation, which means that the output shaft rotates clockwise in response to an increasing Demand signal. The CPS rotation is also normally set to CW, which means it provides an increasing Position feedback signal to the actuator's DCM when the output shaft rotates clockwise. The CPS setting may need to be changed if reversing the direction of actuator rotation.

There are two procedures for changing direction of actuator travel outlined below. The first is a simple method that requires no special adjustments to the CPS-4 or no change to the CPS rotation setting in the DCM configuration. When using this method, the external feedback signal will be inversely proportional to the Demand input signal after the change is complete. For example, given a 4–20 mA Demand input, the corresponding 2-wire Position feedback signal from the CPS-4 will be 20–4 mA.

Figure 4.

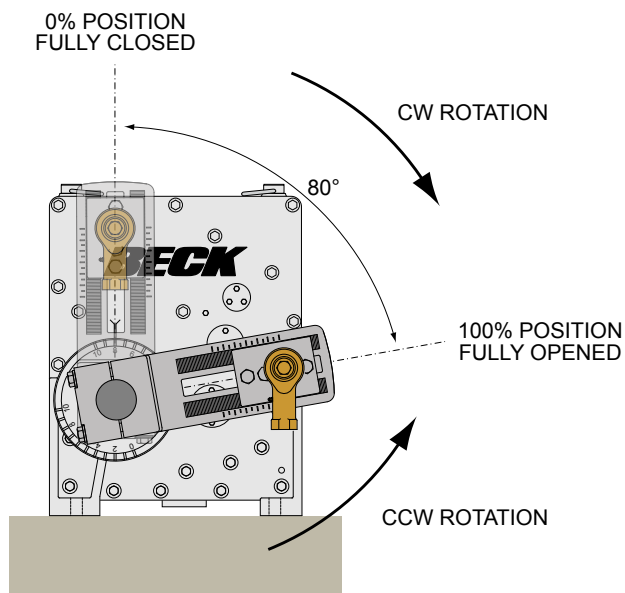

NOTE: The crank arm in the figure above may be adjusted to any start angle. The orientation and rotation shown here has been randomly selected for the purpose of this example.

The second procedure is necessary if it is desirable to keep the Position feedback signal from the CPS-4 direct-acting with respect to the Demand input; i.e., a 4–20 mA Demand signal will result in a 4–20 mA feedback. This procedure is more involved because it requires changing the CPS rotation setting in the DCM and also making some mechanical calibration adjustments to the CPS-4.

Procedure 1

Simply change direction of travel using any of the three standard methods below.

PUSHBUTTONS method

1. Position the actuator to the desired 0% position.
2. Press and hold the “CALIBRATE” and “POS 0%” pushbuttons on the DCM's local interface panel until the “ACKNOWLEDGE” LED lights.

OR

1. Position the actuator to the desired 100% position.
2. Press and hold the “CALIBRATE” and “POS 100%” pushbuttons on the DCM's local interface panel until the “ACKNOWLEDGE” LED lights.

*If the “ACKNOWLEDGE” LED does not light, but the “POSITION” LED does light, the signal is out of acceptable range and was not accepted by the DCM.

HART method

HART DD Menu Location: MENU 5A

Functions> Configuration> General Setup

Command: actuator Dir

Selections:

CW Incr - select if the desired output shaft rotation is clockwise on increasing Demand signal.

CCW Incr - select if the desired output shaft rotation is counter-clockwise on increasing Demand signal.

SERIAL command method

Command: drvdir

Arguments:

0: CW - select if the desired output shaft rotation is clockwise on increasing Demand signal.

1: CCW - select if the desired output shaft rotation is counter-clockwise on increasing Demand signal.

(e.g.: “drvdir 0” to select clockwise rotation on increasing Demand signal.)

Note that changing direction of travel using any of the previous three methods alone will result in a properly functioning CCW actuator; however, the 2-wire Position feedback signal from the actuator's CPS-4 will be reverse-acting or opposite the Demand signal (i.e., a 4–20 mA Demand signal to the actuator will have a corresponding feedback signal of 20–4 mA). If a direct-acting feedback is desired (4–20 in equals 4–20 out) then use Procedure 2 below.

Procedure 2

This procedure changes the direction of actuator travel and also reverses the 2-wire Position feedback signal so it remains direct-acting and directly proportional to the Demand input signal (i.e., applying a 4–20 mA Demand input to the actuator results in a 4–20 mA Position feedback signal response). This procedure requires more steps than the previous procedure outlined above.

1. Position the actuator to its 0% position and place the Handswitch in "STOP". Make sure the 2-wire Position feedback signal reads 4 mA.
2. Change the CPS Rotation setting to match the desired actuator travel. For example, when changing the actuator's direction of travel from CW to CCW you will also need to change the CPS rotation setting in the DCM configuration from CW to CCW. This change can only be made using a serial command via the DCM serial port. Use serial command "cpsrotation n ",

where $n = 0$ to set CW rotation and $n = 1$ to set CCW rotation.

3. Set the CPS Rotation switch on the CPS-4 (see image below) to match the CPS rotation setting established in step 2 above. To change from CW to CCW, rotate the switch fully CCW (approx. 270°) to the switch's hard stop. Do the opposite to change from CCW to CW. Note that the CPS rotation normally must match the actuator direction of travel in order for the 2-wire Position feedback signal to be direct-acting with respect to the Demand input signal.
4. At this point, the 2-wire Position feedback from the CPS should have shifted from 4 mA to a value closer to the 100% value of 20 mA. Make a note of the offset between the feedback reading and the desired 20 mA value and adjust the Zero pot. on the CPS-4 (see image below) as required to bring the feedback signal back to 20 mA (the new desired value).
5. Change the actuator direction of travel using one of the three methods outlined in Procedure 1, above (i.e., HART, Pushbuttons or Serial).
6. Place the Handswitch in "AUTO" and verify proper operation of the actuator.

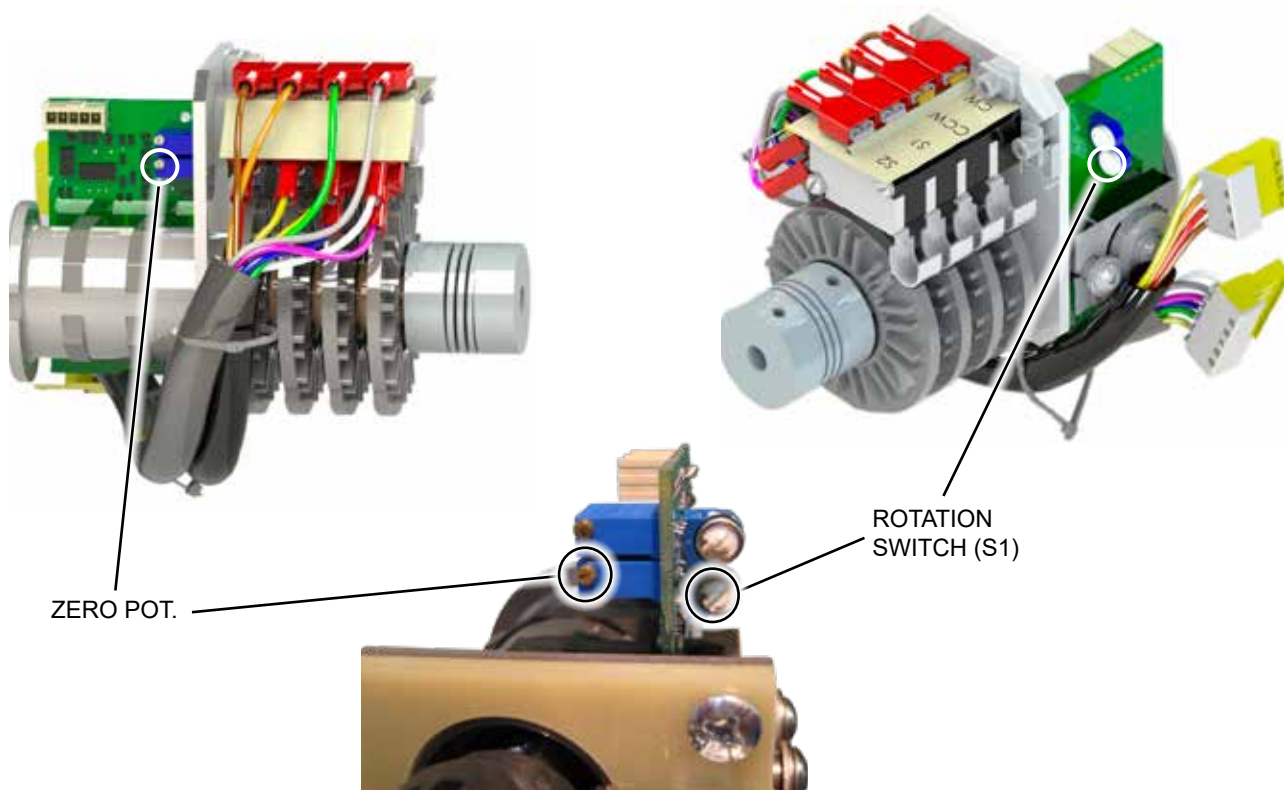

CPS-4 ROTATION SWITCH & ZERO POT. (BOTH VERSIONS SHOWN)

CONFIGURATION / CALIBRATION

DEGREES ROTATION

Actuator degrees rotation (or travel) is defined as the number of degrees traveled by the output shaft between the 0% to 100% positions. The Group 22 actuator can be calibrated for a maximum of 100 degrees of rotation between the mechanical stops that are cast into the body approximately 108 degrees apart.

The standard output shaft rotation is 100 degrees. It is recommended that the full 100 degree rotation be utilized to maximize the torque output of the drive, and to maintain the maximum resolution (max. number of steps). The linkage can be arranged to provide a driven equipment rotation of less than 100 degrees while maintaining the Beck actuator rotation of 100 degrees. Maintaining full travel also results in the mechanical travel index corresponding with travel in percentage.

Some exceptional applications may require less travel. A position calibration and over-travel switch change can be performed to reduce actuator travel. Full stroke rotation of 60 degrees or less is not recommended. Beck sales engineers are available for application advice or Link-Assist analysis.

POSITION CALIBRATION

When it is necessary to reduce or change the amount of Beck output shaft rotation, electronic calibration changes can be done by using pushbuttons, HART, or Serial commands as follows:

0% and 100% Position Calibration Procedure: Physically drive the actuator to the new 0% and 100% positions and use the Pushbuttons, or HART commands to set the new end points.

Changing Travel in Degrees Procedure: This procedure requires HART or Serial commands to change the travel length in degrees. This method allows the calibration to be changed without running the actuator to the new positions. The 0% position will remain the same, and the 100% position will change to accommodate your calibration.

NOTE: In addition to recalibrating the electronics, the CW / CCW over-travel switches should also be adjusted to open just beyond the new electronic limits; this ensures that manual operation with the Handswitch will not cause over-travel or create a stall condition.

0% and 100% POSITION CALIBRATION PROCEDURE

PUSHBUTTONS method

1. Position the actuator to the desired 0% position.
2. Press and hold the “CALIBRATE” and “POS 0%” pushbuttons on the DCM’s local interface panel until the “ACKNOWLEDGE” LED lights.
3. Position the actuator to the desired 100% position.
4. Press and hold the “CALIBRATE” and “POS 100%” pushbuttons on the DCM’s local interface panel until the “ACKNOWLEDGE” LED lights.
5. Adjust over-travel limit switches as necessary to accommodate the new rotation (page 24).

HART method

HART DD Menu Location: MENU 5B

Functions> Configuration> Position Sensor Setup

Command: Set Pos 0%

Position the actuator to the desired 0% position and run the “Set Pos 0%” function.

HART DD Menu Location: MENU 5B

Functions> Configuration> Position Sensor Setup

Command: Set Pos 100%

Position the actuator to the desired 100% position and run the “Set Pos 100%” function.

CHANGING TRAVEL IN DEGREES PROCEDURE

HART method

HART DD Menu Location: MENU 5A

Functions> Configuration> General Setup

Command: Travel

Enter the full stroke rotation in degrees and press the ENTER key. Remember to press the SEND key to execute the change.

SERIAL command method

Command: travel

Arguments: ###: Enter the full stroke rotation in degrees. (e.g.: “travel 90” for 90 degree rotation)

Note for HART & Serial: The 0% position will remain the same and the 100% position will change to accommodate your calibration.

It is important to note, however, that when the actuator full travel is short-stroked to something less than 100°, the 2-wire Position feedback span is reduced proportionately. For example, the 2-wire Position signal is normally calibrated to provide a 4–20 mA signal (16 mA span) proportional to 0–100% travel of 100°. If the travel is short-stroked to a value less than 100° full travel, such as 60°, then the feedback signal representing the new, shorter full travel is reduced proportionally. In this case, the span would be 60% of 16 mA, or 9.6 mA. Assuming the zero position point was not changed, the resulting 2-wire position signal is 4–13.6 mA representing 0–100% travel. Depending on the short-stroke procedure utilized, the zero position point could be changed, if desired.

Note that the standard 4-wire actuator-powered position signal is also available at terminals 17 (+) and 16 (–). Because this signal is sourced by the DCM, it maintains the full 16 mA span of the 4–20 mA signal to represent full travel, regardless of how much the travel is short-stroked.

CONFIGURATION / CALIBRATION

DEMAND CHARACTERIZATION CURVE

The DCM-2 can be configured to interpret the applied Demand signal for linear or non-linear output shaft position response. Several predefined Demand signal response curves are available for use including: Linear, Square, and Square Root. A chart of each of these predefined responses is provided for your reference.

In addition to the three predefined characterizer curves, the DCM-2 also allows a custom user-defined curve to be configured. This option is called "Special Curve" in the menu.

The Demand characterization curve type can be configured with the following methods.

HART method

HART DD Menu Location: MENU 5C

Functions> Configuration> Demand Setup

Command: Dem Curve

Selections:

Linear - select if the actual position % should match the applied Demand %.

Square Root - select if the actual position % should match the square root of the applied Demand %.

Special Curve - select if a user-defined response is desired. (see characterization on the following page to define the desired response curve)

Square - select if the actual position % should match the square of the applied Demand %.

(e.g.: "demfunc 0" sets the actuator to a linear Demand response)

SERIAL command method

Command: demfunc

Arguments: # Enter the integer that represents the desired Demand signal response as follows:

0: Linear - select if the actual position % should match the applied Demand %.

1: Square Root - select if the actual position % should match the square root of the applied Demand %.

4: Special - select if a user-defined response is desired. (see characterization on the following page to set the desired response curve)

5: Square - select if the actual position % should match the square of the applied Demand %.

(e.g.: "demfunc 0" sets the actuator to a linear Demand response)

DEMAND SIGNAL RESPONSE CURVES

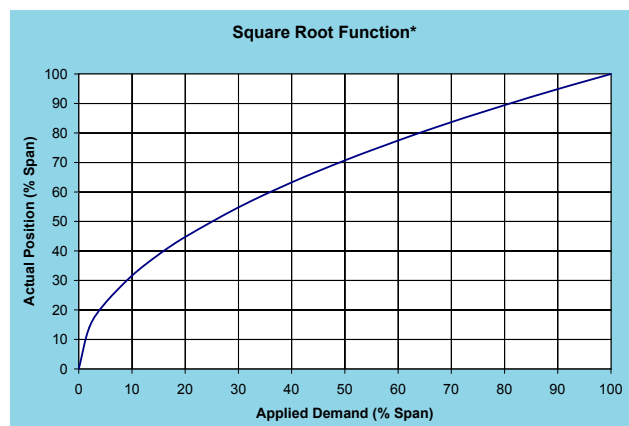
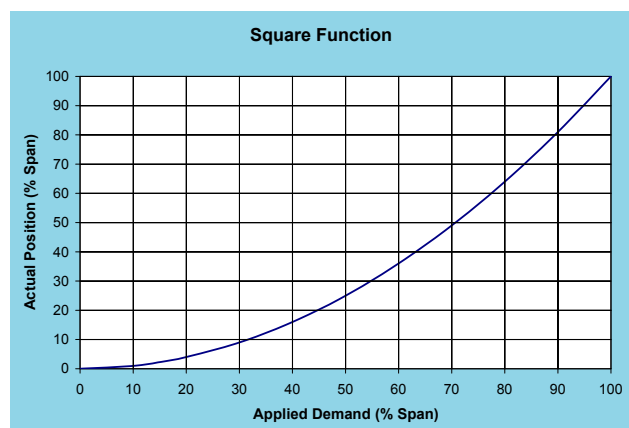
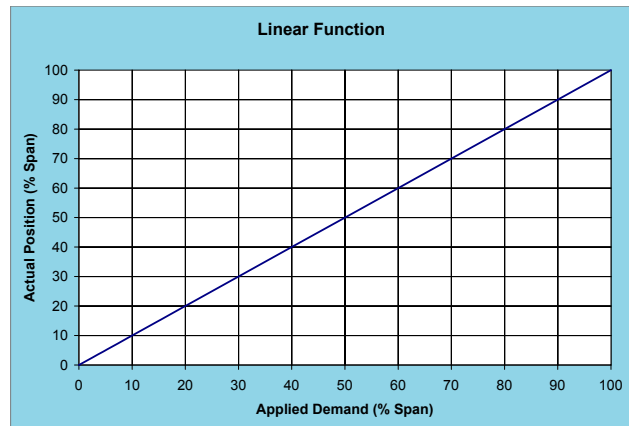

NOTE

Implementing a square root characterization creates extremely high gain when a the Demand signal is below 10%. This causes instability and is unsuitable for control in this region. Do not apply this curve if the control loop may need to modulate at the lower range of travel.

USER-DEFINED CHARACTERIZATION

Special curves may be created from up to 20 segments, each of which has a node for a starting point and a node for an ending point. All 20 segments do not have to be used, but the used segments must be grouped together starting with segment 1. Segments cannot be skipped.

A node is a coordinate comprised of an X,Y point. When defining nodes, X-values and Y-values must increase as the node number increases. For example, the X-value and Y-value of node 2 must be higher than the X-value and Y-value of node 1. Nodes cannot be skipped. Always start at node 1.

Unless otherwise specified, the Special curve ships from the factory defined as a linear function (i.e., one segment beginning with node 1 at X = 0%, Y = 0% and ending with node 2 at X = 100%, Y = 100%). X-values are typically chosen to give a reasonable spacing in Y-values. Y-values are calculated from X-values using the desired formula, or are chosen from X-values picked from a table of data.

The example table shown here describes the X and Y values used to approximate a square function. The result of this example is shown in the accompanying graph. In this case, the Y coordinate of any point is equal to the X coordinate squared. (e.g.: for node 4 the X-value is 50% or 0.5. The resultant Y-value is 0.5 x 0.5 = 0.25 or 25%).

This example uses 5 segments to approximate the square curve. Segments 1 through 5 are needed, so nodes 1 through 6 are used.

The following methods can be used to configure a user-defined characterization curve.

HART method

HART DD Menu Location: MENU 14

Functions>Configuration>Demand Setup>Dem Curve Spcl

Command: DemNode1X

Enter desired X value as a percentage for node 1

Command: DemNode1Y

Enter desired Y value as a percentage for node 1

Repeat above configuration for each node required.

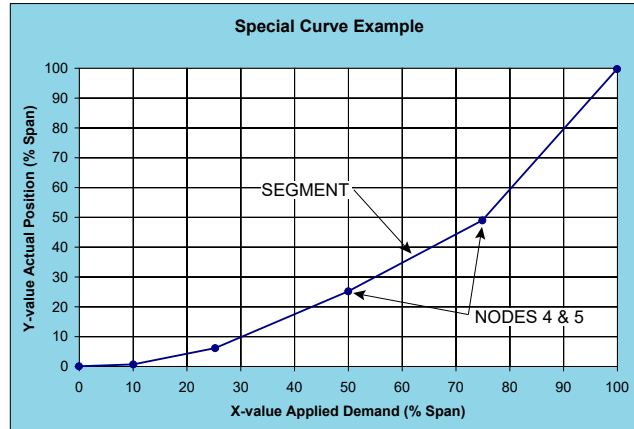

Node	Demand X-value % Span	Position Y-value % Span
1	0%	0%
2	10%	1%
3	25%	6%
4	50%	25%
5	75%	49%
6	100%	100%

SERIAL command method

Command: charset

Arguments: n1, n2, n3

Where:

- n1 = node number.
- n2 = X-value as a percentage.
- n3 = Y-value as a percentage.

Values must be separated by commas as shown.

(e.g.: "charset 4, 50, 25" sets node 4 to position the actuator to 25% with a 50% Demand signal applied to the actuator). *Repeat command for each node required.*

Command: charlist

Arguments: ### Enter the integer value of the defined node you wish to display (between 1 and 21) or "all" to display all defined nodes.

(e.g.: "charlist 4" displays the X and Y values defined for node 4)

Command: charclear

Arguments: ### Enter the integer value of the defined node you wish to clear and set to unused. Note: this function will set all nodes higher than the specified nodes to unused.

(e.g.: "charclear 4" sets nodes 4 through 21 to unused.)

CONFIGURATION / CALIBRATION

LOSS OF DEMAND SIGNAL (LOS)

The DCM-2 is capable of determining if the Demand input signal to the actuator is outside of an acceptable range. The DCM-2 uses a configurable loss of signal (LOS) threshold to determine if the Demand signal falls below a minimum value. Unless otherwise specified in the original order, the factory set threshold is 3.2 mA. When the DCM-2 senses a LOS condition, it will provide a system alarm, and illuminate the "DEMAND" LED. The actuator will also respond in a predetermined manner.

The DCM-2 can be configured for two LOS actions:

1. **Stay in Place** – the actuator output shaft stays in place until the Demand signal returns to the acceptable range. This is the factory default.
2. **Go-to-Position** – the actuator output shaft will move to a preset position, designated in percentage of travel. For example, if the LOS action is set for GTP 50%, the actuator output shaft will actuator to the 12 mA position (based on a 4-20 mA span).

The LOS parameters can be configured using HART or SERIAL commands.



CAUTION

The following procedures could cause the actuator to reposition, which can adversely affect the process and cause potentially dangerous conditions.

HART method

HART DD Menu Location: MENU 5C

Functions> Configuration> Demand Setup

Command: LOS Mode

Selections:

Stay - select if the actuator should hold output shaft position when a loss of signal occurs.

Go-to-pos - select if the output shaft should go to a specific position when a loss of signal condition occurs. Configure the position with LOS Pos.

Command: LOS Pos

Enter the desired output shaft position the actuator will achieve upon loss of Demand signal. This value is entered as a percentage of full travel. Command LOS Mode must be set to "Go-to-Pos" to use this feature.

Command: DemLimLwr

Enter the decimal value of the lower threshold for detecting a loss of control signal. (typically 3.2 mA for a 4-20 mA application.)

SERIAL command method

Command: demlos

Arguments: ###: Enter the desired mode or lower Demand threshold as follows:

sip: select if the actuator should hold its current position when a loss of signal condition occurs.

gtp: select if the actuator should go to a specific position when a loss of signal condition occurs. Configure the position with the demlogtgp serial command.

(e.g.: "demlos sip" will cause the actuator to hold position during a loss of signal condition)

OR

n: Where n is a decimal value of the lower threshold for detecting a loss of control signal.

(e.g.: "demlos 3.2" sets the lower LOS threshold to 3.2 mA)

Command: demlogtgp

Arguments: ###: Enter the desired loss of signal position as a percentage of actuator travel span.

(e.g.: "demlogtgp 50" will position the actuator to 50% when a loss of signal condition occurs and the demlos command is set to gtp.)

Command: demlogtgp delay n

Arguments: n Time delay in seconds before the actuator will move to the position set in "demlogtgp" (0 to 25.5 seconds). Default is "0".

Entering this command without an argument will return the present GTP and delay settings.

STEP SIZE

Step size represents the minimum amount that the Demand signal must change to initiate a change in actuator position.

When the actuator is in AUTO mode, the DCM-2 runs the motor until the output shaft position matches the Demand signal. When they match, power is removed from the motor. The Demand signal must change by at least the step size before power is returned to the motor.

The step size is factory set at 0.15% of span unless otherwise specified at the time of order. The step size is adjustable from 0.1% to 2.5% when the actuator is configured for 100 degrees of travel, but adjustment is typically not required. The minimum step size regardless of travel is 0.1°. It may be advantageous in certain applications where noise or other problems exist, to increase the step size slightly to prevent excessive modulation.

The step size can be changed using the following methods.

HART method

HART DD Menu Location: MENU 5A

Functions> Configuration> General Setup

Command: Step Size

Enter the step size as a decimal percentage of span and transmit the data to the DCM-2 to execute the change.

SERIAL command method

Command: stepsize

Arguments: #.##%: Enter the stepsize as a percentage of travel span. (e.g.: "stepsize 0.15%" for 0.15% of travel span OR "stepsize 0.15" for 0.15 degrees of travel span)

Note: If the percent (%) symbol is left off of the command, the DCM-2 will consider the unit to be degrees instead of percent.



CAUTION

The following procedures could cause the actuator to reposition, which can adversely affect the process and cause potentially dangerous conditions.

STALL PROTECTION

The DCM-2 board provides protection of the actuator motor and gearing in the event of a stall condition. A stall condition occurs when the actuator is attempting but is unable to move to a desired position for a defined period of time due to a mechanical impediment or excessive load.

The DCM-2 senses that the actuator is unable to balance by monitoring the current applied to the motor windings. If the current is continuously applied to one motor winding longer than the configured "stall time", the actuator shuts off motor power and prevents further actuator movement. When this occurs, the STAT and STALL LEDs will illuminate.

Resetting the actuator and restoring normal operation is achieved by reversing the Demand signal to the drive, submitting a reset command via HART or Serial port, or cycling the actuator power.

The stall protection feature can be enabled or disabled and the stall time may be configured between 30 and 300 seconds. This feature is factory enabled and set for 300 seconds. If reconfiguring, it is advisable to configure the stall timer with a value greater than the maximum stroke time to avoid false stall alarms. The following methods are available to configure the stall protection feature.

HART method

HART DD Menu Location: MENU 5A

Functions> Configuration> General Setup

Command: StallProt

Selections:

Enabled - Select to enable stall protection.

Disabled - Select to disable stall protection.

Command: Stall Time

Enter the stall time in seconds as an integer. Valid stall times are between 30 - 300 seconds.

HART DD Menu Location: MENU 7

Functions> Manual Operation

Command: Reset Stall

Running this function will reset a stall condition.

SERIAL command method

Command: stallprot

Arguments:

0:Disabled (Motor continues to run if stalled.)

1:Enabled (Power removed from motor if stalled.) (e.g.: "stallprot 1" enables stall protection)

Command: stalltime

Arguments: ###: Enter the stall time in seconds as an integer. Valid stall times are between 30 - 300 seconds. (e.g.: "stalltime 45")

Command: unstall - resets a stall condition.

CONFIGURATION / CALIBRATION

POSITION FEEDBACK SIGNAL

DCM-2 control electronics provide a 4-20 mA analog output signal that represents the actuator output shaft position. The DCM-2 monitors an internal position voltage from the CPS-4, controls the actuator position, and sources a 4-20 mA signal to terminals 16(-) and 17 (+). The feedback will correspond with the 0% and 100% output shaft positions, as determined by the position calibration (page 29). There is no need for a separate feedback calibration.

The user has the option of enabling or disabling the position feedback signal. The factory default configuration will have the feedback enabled. When the feedback is enabled, but not in use (i.e., not wired to a load) the STAT and FB OPEN LEDs will illuminate. This status alarm is helpful in alerting the user to open feedback wiring, but can be a nuisance when the feedback is purposely disconnected or unused. Disabling the feedback signal turns off the output and eliminates the status alarm. If HART or serial communications are not immediately available to disable the feedback signal, you can apply up to an 800 ohm load resistor across the feedback terminals 16 (-) and 17 (+) to simulate a feedback loop and eliminate the alarm.

Use the HART or Serial Commands (detailed on the next page) to set the Feedback signals and corresponding output shaft positions as detailed below.

If desired, the milliamp position feedback values for 0% and 100% positions can be configured different than the respective standard factory calibration of 4 mA and 20 mA. The 0% position can be configured between 3-16 mA, while the 100% position can be configured between 7-21 mA. The 100% milliamp value must exceed the 0% value by at least 4 mA for proper configuration.

Also, reversed (decreasing direction) Feedback may be selected so that the position resulting from a 4 mA Feedback signal corresponds to the position typically resulting from a 20 mA signal; e.g., 4 mA = 100% position and 20 mA = 0% position. Setting the 0% position to 20 mA will automatically set the 100% position to 4 mA (and vice-versa), and will activate the reverse (decreasing) Feedback function. After accepted, these settings may then be changed as detailed in the paragraph above, only opposite; i.e., a valid 0% position Feedback value is 7–21 mA, while a 100% position may be set at 3–16 mA. The difference between the values can be no less than 4 mA and no greater than 18 mA.

A relationship exists between the position feedback signal and the output shaft position. The factory calibrated relationship between them is linear. For example, when the output shaft is at 50%, the position feedback signal will show 50% (12 mA for a 4-20 mA configuration). Another relationship is available called “inverted Demand”. It may be preferable to configure the feedback for an “inverted Demand” relationship when the actuator is configured with a non-linear Demand.

The following example assumes a 4-20mA Demand and position configuration. If the Demand is set to a square characterization, then a 12mA Demand corresponds to 25% position. If the position feedback is set to linear, then feedback at 25% would be 8mA. For some control systems, having the Demand at 12mA and the feedback at 8mA may cause a deviation alarm. The feedback characterization can be set to the inverse Demand curve so the Demand and feedback match when the actuator is balanced. In this example, with feedback set to Inverse Demand and the output shaft position at 25%, the feedback signal would be 12mA.

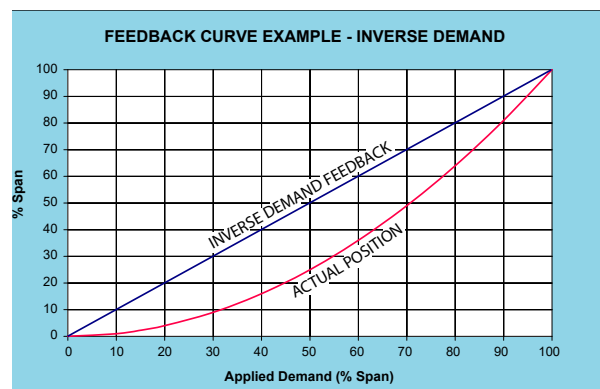
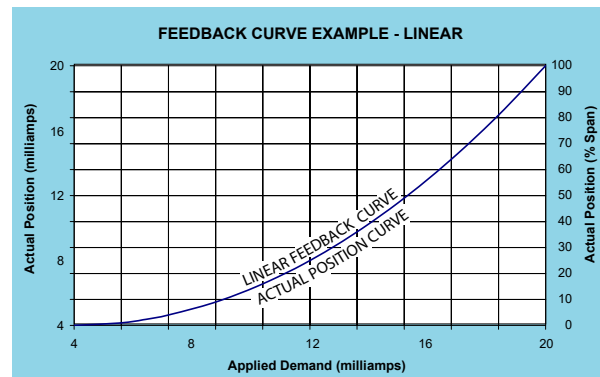

The following methods describe how to enable/disable position feedback, Set the 0% and 100% milliamp values, and select the desired feedback response.

HART method

HART DD Menu Location: MENU 5D

Functions> Configuration> Feedback Setup

Command: Feedback

Selections:

Enabled - Select to enable position feedback.

Disabled - Select to disable position feedback.

Command: FB RngLwr

Enter the decimal milliamp value that corresponds with 0% position (typically 4 mA)

Command: FB RngUp

Enter the decimal milliamp value that corresponds with 100% position (typically 20 mA)

Command: FB Curve

Selections:

Linear - Select for Linear feedback signal

Inverted Demand - Select for Inverted Demand feedback signal

SERIAL command method

Command: iomode

Arguments: #:

0: Disabled - Select to disable position feedback.

1: Enabled - Select to enable position feedback. (e.g.: "iomode 1" enables position feedback)

Command: fdbk0pctma

Arguments: #.##: Desired Feedback signal in mA at 0% output shaft position. The value limit may be no less than "3.00" or, if reversed (decreasing direction), no greater than "21.00".

Command: fdbk100pctma

Arguments: #.##: Desired Feedback signal in mA at 100% output shaft position. The value limit may be no greater than "21.00" or, if reversed (decreasing direction), no less than "3.00".

Command: fdbkfunc

Arguments: #:

0:Linear - Sets the feedback to Linear.

1:Inverse Demand - Sets the feedback to Inverse Demand.

(e.g.: "fdbkfunc 0" sets the position feedback to linear)

DEMAND CALIBRATION

Group 22 actuators are calibrated to respond to a 4-20 mA (or 1-5 Vdc) control signal to set the actuator position. Factory calibration assigns 4 mA as the 0% and 20 mA as the 100% Demand signal response unless otherwise specified.

It is not necessary to calibrate the Demand input when the actuator is installed. Several guidelines must be followed if you elect to calibrate the Demand response. The value for 0% must be greater than 0.5 mA and the value for 100% must be less than 21 mA. The difference between 0% and 100% must be at least 4 mA. Contact the factory for details regarding split-range operation.

PUSHBUTTONS method

1. Ensure the Handswitch is in the "STOP" position. This will prevent the actuator from repositioning during this procedure.
2. Apply the desired 0% Demand input signal to the actuator (e.g., 4 mA for 4–20 mA input).
3. Press and hold the "CALIBRATE" pushbutton on the DCM customer interface panel, then press the "SET DEM 0%" pushbutton until the "ACKNOWLEDGE" LED is lit.*
4. Apply the desired 100% Demand input signal to the actuator (e.g., 20 mA for 4–20 mA input).
5. Press and hold the "CALIBRATE" pushbutton on the DCM customer interface panel, then press the "SET DEM 100%" pushbutton until the "ACKNOWLEDGE" LED is lit.*
6. Turn the Handswitch to the "AUTO" position. NOTE: The actuator may reposition.
7. Run the actuator through its full operating range to ensure proper response to the Demand input signal.

HART method

HART DD Menu Location: MENU 5C

Functions> Configuration> Demand Setup

Command: DemRngLwr

Enter the decimal value of the 0% Demand signal (e.g.: 4.00). Remember to press the SEND key to execute the change.

Command: DemRngUp

Enter the decimal value of the 100% Demand signal (e.g.: 20.00). Remember to press the SEND key to execute the change.

SERIAL command method

Commands: dem0pctma, dem100pctma

Arguments: #.##: Enter the decimal value for the 0% and 100% respectively. (e.g.: dem0pctma 4.00)

CONFIGURATION / CALIBRATION

TORQUE SENSING

Group 22 actuators are equipped with torque sensing. This technology allows for torque measurement, historic data collection, overtorque alarms, and overtorque protection.

The torque applied at the output shaft of the actuator is measured and reported as a percentage of the rated actuator torque (e.g. a 3,000 lb-ft model 22-309 with a 50% torque reading is applying 1,500 lb-ft of torque). The live torque measurement can be accessed through HART communications (MENU 1) or serial port (torq command). Historical peak measurements are recorded for 10 equal segments of travel in both the CW and CCW travel directions. This historic data is available through HART communications (MENU 11) or serial port (torqprof command).

Proper configuration of the torque sensor is necessary to take advantage of its features. A "torque null" and a "torque constant" value, which are analogous to a zero and a span are unique to each actuator and will be affixed to the body of the unit inside of the DCM compartment. These values will be factory configured on the DCM-2, but will require configuration if the DCM-2 is ever replaced.

When the torque reaches an alarm threshold (factory configured for 105%), a status alarm will be initiated causing the STAT and TORQUE LEDs to illuminate. The threshold can be configured to alarm between 60% and 105%. Disabling the torque sensor also disables the torque alarm. When the measured torque drops below the threshold the status alarm is automatically reset.

The following methods allow the user to enable/disable torque sensing, set the torque null, set the torque constant, and set the torque alarm threshold.

HART method

HART DD Menu Location: MENU 5E

Functions> Configuration> Torque Setup

Command: Trq/Thrust

Selections:

Enabled - Select to enable torque sensing.

Disabled - Select to disable torque sensing.

Command: Trq Null

Enter the torque null value that is affixed to the actuator body inside the DCM compartment.

Command: Trq Constant

Enter the torque constant value that is affixed to the actuator body inside the DCM compartment.

Command: Alarm Level

Enter the torque alarm threshold as a percentage of rated actuator torque (60%-105%).

SERIAL command method

Command: torqenable

Arguments:

0:Disable torque sensing and torque alarm.

1:Enable torque sensing and torque alarm.

(e.g.: "torqenable 1" enables torque sensing and torque alarm)

Command: torqzero

Arguments: ###: Enter the torque null as an integer that is affixed to the actuator body inside the DCM compartment.

Command: torqspan

Arguments: ###: Enter the torque constant as an integer that is affixed to the actuator body inside the DCM compartment.

Command: torqalarm

Arguments: ###: Enter the torque alarm threshold as a percentage of rated actuator torque (60%-105%).

OVERTORQUE PROTECTION

Overtorque protection is a feature of the actuator that is intended to protect both the actuator and driven equipment from damage when the torque level exceeds a certain threshold by cutting power to the motor. Unless otherwise specified at the time of order, this feature is disabled as a factory setting. It can be enabled in the field using either HART or serial command methods. The factory configured threshold is 115% of rated actuator torque.

The following methods show how to enable/disable the overtorque protection and how to set the threshold which has an acceptable range between 70% and 115%.

HART method

HART DD Menu Location: MENU 5E

Functions> Configuration> Torque Setup

Command: Ovt Prot

Selections:

Enabled - Enables Over torque protection.

Disabled - Disables Over torque protection.

Command: ShutDwnTrq

Enter the over torque protection threshold as a percentage of rated actuator torque (70%-115%).

SERIAL command method**Command:** ovtstop**Arguments:****0:**Disables Over torque protection.**1:**Enables Over torque protection.

(e.g.: "ovtstop 1" enables Over torque protection)

Command: ovtstoplevel**Arguments:** ###: Enter the over torque protection threshold as a percentage of rated actuator torque (70%-115%).**RESTORE FACTORY SETTINGS**

All DCM-2's ship from the factory configured per the customer preferences at the time of order. A complete copy of the factory configuration is stored on the DCM-2. You can revert to the factory settings at any time through one of the following methods. Note that when the factory settings are restored, the Operation Mode (HART MENU 7 or serial command opmode) will not be changed for safety reasons.

HART method**HART DD Menu Location:** MENU 5

Functions> Configuration

Command: Restore to Factory

Running this function will restore all configurable parameters to the original factory settings.

SERIAL command method**Command:** restoremodes**Arguments:****1:** Used as a safety measure, the number one must be entered as an argument to prevent someone from running the restoremodes command errantly.

(e.g.: "restoremodes 1" runs the restore to factory function)

TEMPERATURE SENSING

DCM-2s are equipped with an internal temperature sensing circuit. The real-time temperature and the historical temperature extremes (low and high) are available.

Temperature units can be selected to show either Fahrenheit or Celsius.

An alarm condition initiates if the actuator's real-time temperature falls outside the actuator rating (see "General Specifications", page 4). The STAT LED and the TEMP F LED will light, and will automatically reset when the temperature is once again within the actuator rating.

View real-time temperature & historical extremes:**HART** method**Command:** Temp

Displays the real-time temperature as read by the DCM-2.

DD Menu Location: MENU 1**Command:** High Temp

Displays the historical high temperature.

Command: Low Temp

Displays the historical low temperature.

DD Menu Location: MENU 3D

Functions>Statistics

SERIAL command method**Command:** temperature**Arguments:**

When entered with no argument, the command returns the real-time temperature as well as the historical high and low temperatures.

Set temperature units:**HART** method**Command:** Temperature Unit**DD Menu Location:** MENU 4B

Functions>Configuration>General Setup

Selections:**degF** - Set the temp. units to degrees Fahrenheit.**degC** - Set the temp. units to degrees Celsius.**SERIAL** command method**Command:** temperature *n***Arguments:** *n***F:** Set the temp. units to degrees Fahrenheit.**C:** Set the temp. units to degrees Celsius.

MAINTENANCE

COMPONENT REPLACEMENT

The Group 22 was designed modularly for ease of maintenance and parts replacement. The individual components of the actuator are available in replacement parts kits as detailed in the replacement parts kits tables in this section. Each replacement parts kit includes the component(s), necessary hardware, and detailed instructions for installation of the parts.

HOW TO ORDER SPARE PARTS

Any customer replacement kit may be purchased for spare parts, however several kits have been selected by the factory as recommended spares. Contact your Beck Sales Engineer for questions regarding recommended replacement parts particular to your application. Parts may be ordered by mail, telephone, fax or e-mail, with the confirming order sent to the factory.

ROUTINE MAINTENANCE

Beck actuators require only a minimum of routine maintenance. At regular plant maintenance intervals, a visual inspection is recommended to verify that the connection to the final control element is intact and operating normally. If vibration is present, check the electrical terminal connections and other hardware for tightness. Check the conduit seals for any moisture penetration and reseal if necessary.

LUBRICATION

The Group 22 actuator has a grease filled gear housing, so periodic lubrication is not required. However, to extend the life of the linkage, rod ends should be lubricated periodically.

GASKETS

During routine service, inspect removed cover gaskets for wear or damage. In order to protect internal components, worn or damaged gaskets and O-rings should be replaced.

To remove, scrape all of the old adhesive and gasket material from the body housing and cover. The DCM cover, Terminal Block cover and Position Sensing (Control End) cover have self-adhering, silicone rubber gaskets. Peel the backing off the replacement gasket and carefully apply to the actuator body. Other gaskets are a cork-rubber composite. Cement the new gasket to the actuator body using a gasket cement such as 3M #847 Rubber and Gasket Adhesive, or equivalent.

MOTOR

The motor assembly is not field-repairable and is intended to last for the lifetime of the actuator. Disassembly of the motor will result in a loss of torque that can only be restored by returning the motor to the factory for re-magnetizing.

If you suspect a motor problem, contact the factory for assistance.



CAUTION

To prevent sudden movement, block the actuator crank arm before removing the motor—failure to do so could cause serious injury or damage to equipment.

KITS FOR RECOMMENDED REPLACEMENT PARTS

Replacement Kit	22-309	22-409	Kit Part No.
Control End Assembly	X	X	12-8065-05 / 12-8065-15
DCM Replacement (1-phase)	X	N/A	12-8061-75 (DCM-2 p/n 12-8224-41)
DCM Replacement (1-phase) CE rating	X	N/A	12-8061-78 (DCM-2 p/n 12-8224-45)
DCM Replacement (3-phase)	N/A	X	12-8061-85 (DCM-2 p/n 12-8224-51)
DCM Replacement (3-phase) CE rating	N/A	X	12-8061-88 (DCM-2 p/n 12/8224-55)
Gasket Set	X	X	12-8061-09
Fuse Kit - 8A 22-309 (120 Vac, 1-phase) & 22-409 (208 Vac 3-phase)	X	X	12-8061-53

OTHER AVAILABLE KITS FOR REPLACEMENT PARTS

Replacement Kit	22-309	22-409	Kit Part No.
CPS-4 Switch Assembly	X	X	12-8061-06/12-8061-36
CPS-4 P.C. Board	X	X	12-8065-07
CPS-4 Coupling	X	X	12-8061-08
Mounting Shim Set	X	X	12-8061-11
Handswitch Assembly	X	X	12-8061-12
Capacitor	X	N/A	12-8061-14
Motor	X	X	12-8061-01
Handwheel/Dampener	X	X	12-8061-02
Self-Locking Mechanism (SLM) Rebuild	X	X	12-8061-69
Service Screw Set	X	X	12-8061-10
Fuse Kit - 8A (DCM), 4A (Input - 240 Vac, 1-phase)*	X	N/A	12-8061-50
Optional Transformer fuse (9A, 208 Vac) (3 req'd)	X	X	11-1372-10
Optional Transformer fuse (8A, 240 Vac) (3 req'd)	X	X	11-1372-09
Optional Transformer fuse (4A, 380 Vac) (3 req'd)	X	X	11-1372-06
Optional Transformer fuse (4A, 416 Vac) (3 req'd)	X	X	11-1372-06
Optional Transformer fuse (4A, 480 Vac) (3 req'd)	X	X	11-1372-06
Optional Transformer fuse (3.5A, 575 Vac) (3 req'd)	X	X	11-1372-08
Transient Protector (120 Vac, 1-phase)**	X	N/A	12-8061-44
Transient Protector (240 Vac, 1-phase)**	X	N/A	12-8061-42
Transient Protector (208 Vac, 1-phase)**	N/A	X	12-8061-43

*Select the proper Fuse Kit based on your actuator operating voltage.

**Select the proper Transient Protector Kit based on your actuator operating voltage.

GROUP 22 TRANSIENT PROTECTION

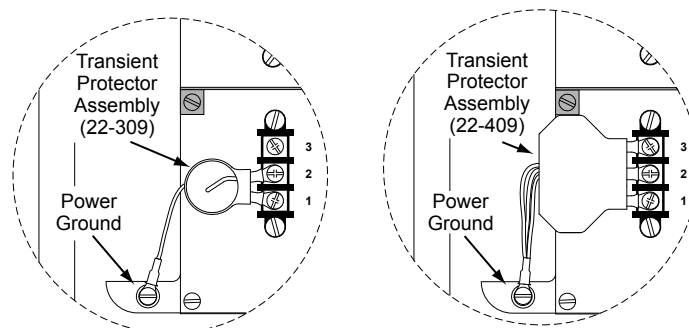

MAINTENANCE

FUSES

Group 22 actuators contain fuses to protect the wiring of the actuator from over-current conditions. The fuses will not clear due to actuator stalls or high duty cycles. If the fuses clear, either excessive voltage was connected to the drive, or an internal actuator short circuit or failure exists.

To find the reason for the fuse clearing, first check the applied voltage against the voltage rating stamped on the nameplate of the actuator. If the applied voltage appears correct, switch off all power, replace the cleared fuses, and restore power. If the actuator works properly, there may have been a momentary problem with the applied power.

22-309 / 22-409

The 22-309 has two fuses and the 22-409 has three fuses, which are located in fuse holders on the DCM-2 chassis assembly. Note that the DCM-2 circuit boards are not powered through the fuses, and therefore the Control Board will remain active if the fuses are cleared.

TRANSIENT PROTECTION

Group 22 actuators use several stages of protection against voltage transients. Circuit boards have various over-voltage protection devices, the DCM-2 assembly that contains the circuit boards has varistor over-voltage protection components on the power wiring, and the customer terminal block has varistor over-voltage protection components on the line power terminals (shown on the previous page). The DCM-2 is not intended to be serviced by the customer. The varistors on the customer terminal block are intended to be replaced by the customer if they are damaged.

Refer to the Replacement parts kit table (page 39) to order the proper surge suppressor kits for your actuator.

DCM-2 REPLACEMENT

The following procedure describes the steps required to replace the Digital Control Module (DCM-2) chassis assembly. These instructions are applicable for DCM-2 Replacement kit numbers 12-8061-75 & 12-8061-78 (for model 22-309) and 12-8061-85 & 12-8061-88 (for model 22-409).

The Group 22 operating parameter table provides a list including some of the more important parameters that may require configuration when replacing a DCM-2. Review and obtain these settings from the original DCM via HART or serial port commands if possible, so they may be configured on the new DCM-2. A DCM serial cable kit is included with the DCM-2 replacement kit.

TABLE 2 - GROUP 22 OPERATING PARAMETERS

(These values will be used to check the calibration of the actuator after the replacement DCM-2 is installed).

Operating Parameters	Recorded Value	HART Interface			Command	Default Value
		HART Menu	Variable Name	Default Value		
Drive Rotation (Increasing Signal)		5A	Drive Dir	CW	drvrotation	0 (CW)
Operation Mode		7	Op Mode	Follow	opmode	0 (follow)
Torque Zero		5E	Trq Null	0*	torq0K	0*
Torque Constant		5E	Trq Const	550*	torqconst	550*
CPS Volts at 0 Degrees		5B	CPS Zero	1.300	cpsvat0deg	1.000
CPS Volts per 100 Degrees		5B	CPS Span	2.400	cpsvper100deg	4.000
Travel		5A	Travel	100.00	travel	100.00
Demand LOS Threshold (mA)		5C	DemLimLwr	3.20	demlos	3.20
Demand LOS Mode		5C	LOS Mode	Stay	demlos	sip
Demand LOS Go To Position (%)		5C	LOS Pos	50.00	demlosgtp	50.00
0% Demand (mA)		5C	DemRngLwr	4.00	dem0pctma	4.00
100% Demand (mA)		5C	DemRngUpr	20.00	dem100pctma	20.00
Stall Time (Sec)		5	Stall Time	300	stalltime	300
Demand Function		5C	Dem Curve	Linear	demfunc	linear
Step Size		5	Step Size	0.10	stepsize	0.10
IO Mode		5D	Feedback	Enabled	iomode	1 (fdbk)
0% Feedback (mA)		5D	FB RngLwr	4.00	fdbk0pctma	4.00
100% Feedback (mA)		5D	FB RngUpr	20.00	fdbk100pctma	20.00
Torque Enable		5E	Trq/Thrust	Enabled	torqenable	1 (enabled)
Over Torque Stop		5E	Ovt Prot	Disabled	ovtstop	0 (disabled)
Polling Address		4	Poll Addr	0	polladr	0
Drive Model		4	Model	22-309	drvmodel	12 (22-309)

*Default values only – The specific numbers for these values are unique to each actuator and are determined during manufacture. These specific numbers are noted on a tag affixed to the actuator body within the Electronics Compartment. Default values should only be used if the specific numbers are unknown.

MAINTENANCE

DCM-2 REPLACEMENT (cont'd)

REQUIRED TOOLS

FOR ALL MODELS

- 1/2" socket wrench
- Torque wrench (appropriate for 10 lb-ft)
- Communications device for calibration

Additional Tools for Model 22-309

- #3 Phillips head screwdriver
- Torque screwdriver with #3 Phillips head bit (appropriate for 50 lb-in)

Additional Tools for Model 22-409

- 7/16" hex socket wrench
- Torque wrenches (appropriate for 50 lb-in and 10 lb-ft)



CAUTION

To prevent electrostatic discharge damage to the electronics, wear a grounding strap during this procedure.

PROCEDURE

DCM-2 chassis assembly diagrams and the Group 22 operating parameter table (Table 2) are provided to help you identify the components and parameters referenced in the following directions.

The DCM-2 is located in the DCM Compartment. Loosen the (4) captive 5/16-18 x 1.75" mounting screws and remove the DCM Compartment cover.

The new DCM-2 operating parameters should be configured to match the existing DCM settings. The Group 22 operating parameter table (Table 2 - page 41) lists some of the settings in approximate order of importance and shows the factory default configuration.

The most commonly changed parameter is the actuator rotation direction. The actuator can be configured for clockwise or counter-clockwise rotation on increasing Demand signal (usually the rotation from closed to open). This direction should be referenced by facing the output shaft side of the actuator.

If replacing an older DCM-H (HART® interface) or DCM-2 and HART® communication is still possible, read and record the values listed in Table 2. These values can be obtained through a HART® handheld communicator or a HART® capable control system. Refer to the HART® appendix for additional information on

handheld communicator connection and DD menu structure.

If replacing an older DCM-L (Local interface) and serial communication is still possible, read and record the values listed in Table 2. These values can be obtained through the DCM serial port using the Beck serial commands. It is possible to obtain this information from the serial port on DCM-H and DCM-2 chassis as well if HART is not available. Refer to the serial port appendix for additional information on serial port connection and commands.



WARNING

Electrical shock hazard. Disconnect power before proceeding. Remove the actuator from line voltage and disconnect any external power sources feeding the auxiliary switches.



Remove the DCM assembly:

1. Place the Handswitch in STOP.
2. Ensure power to the actuator has been disconnected.
3. Disconnect the (5) wiring connectors shown in the appropriate DCM-2 chassis illustration on the following page.
4. **For 22-309:** While holding the DCM handle, loosen the (4) captive mounting screws with a #3 Phillips head screwdriver. Go to Step 5.

OR

- For 22-409:** Loosen the (6) hex mounting screws with a 7/16" socket wrench.
5. Using the handle, remove the DCM-2 chassis from the DCM Compartment.

Install the new DCM assembly:

1. Position the new DCM-2 in the DCM Compartment.
2. Align the locating pin holes in the DCM with the pins in the rear wall of the DCM Compartment as the DCM is seated.
3. **For 22-309:** While pushing the DCM back on its mounting surface, tighten the captive mounting screws with a #3 Phillips head bit. Torque to 50 lb-in (5.6 N·m). Skip to step 4.

OR

- For 22-409:** While pushing the DCM back on its mounting surface, tighten the (6) hex mounting screws with a 7/16" socket wrench. Torque to 50 lb-in (5.6 N·m).

Install the new DCM assembly (continued):

4. Reconnect the (5) wiring connectors.
5. Reconnect power to the actuator.
6. Ensure that the DCM is configured properly.
7. Check the state of the LEDs on the DCM. If either the FWD or REV LED is lit, the actuator will reposition when the Handswitch is returned to AUTO. If desired, change the Demand signal or reposition the actuator using the Handwheel or hand crank until both the FWD and REV LEDs are out. When both LEDs are out, the actuator Demand and position are balanced and the Handswitch can be returned to AUTO.

Check actuator calibration:

Ensure that the actuator calibration is correct by verifying the parameters listed in Table 2 match the parameters on the DCM chassis you are removing. If you were unable to obtain the parameters from the DCM you are replacing, contact the factory with the actuator serial number to obtain the “as-shipped” configuration.

Torque sensor range values (torque null and torque constant) should be entered by utilizing a HART® communicator or through the DCM-2 serial port. Failure to configure these values will cause the torque functions of the actuator to operate incorrectly. These values are specific to each actuator and are affixed to the actuator body inside the DCM compartment.

Before replacing the DCM Compartment cover:

1. Examine the gasket for damage (cuts, tears, missing sections, etc.). If the gasket is damaged, follow steps 2–3 below to replace the gasket; if the gasket does not need replacing, skip to step 4.
2. Clean the mating surface of the actuator body by removing old gasket material and adhesive. Ensure that the mating surface is free of defects or gouges.
3. Peel the backing off the replacement gasket and carefully apply to the actuator body.
4. Replace the DCM compartment cover and torque the (4) captive 5/16-18 x 1.75” mounting screws to 10 lb-ft (14 N•m).

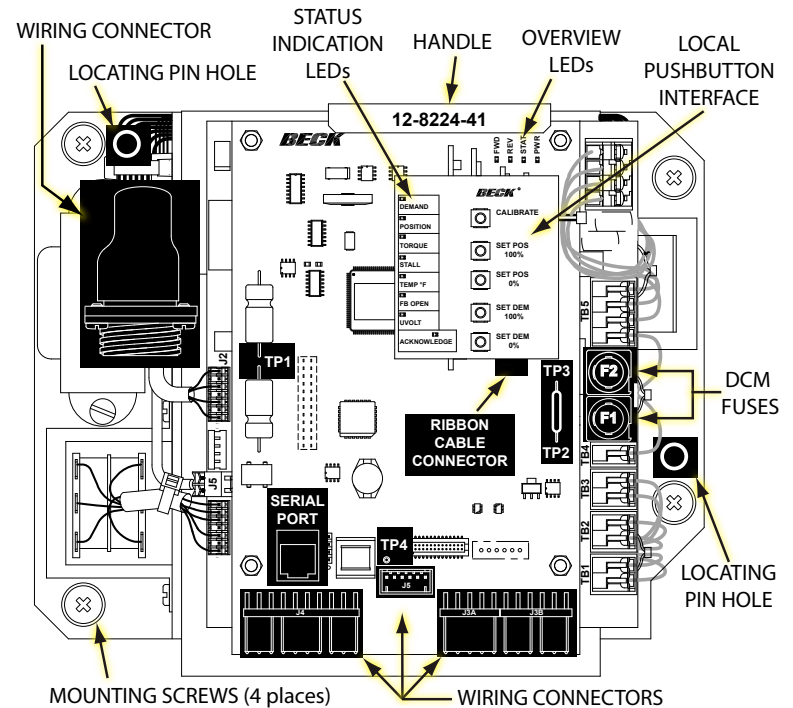
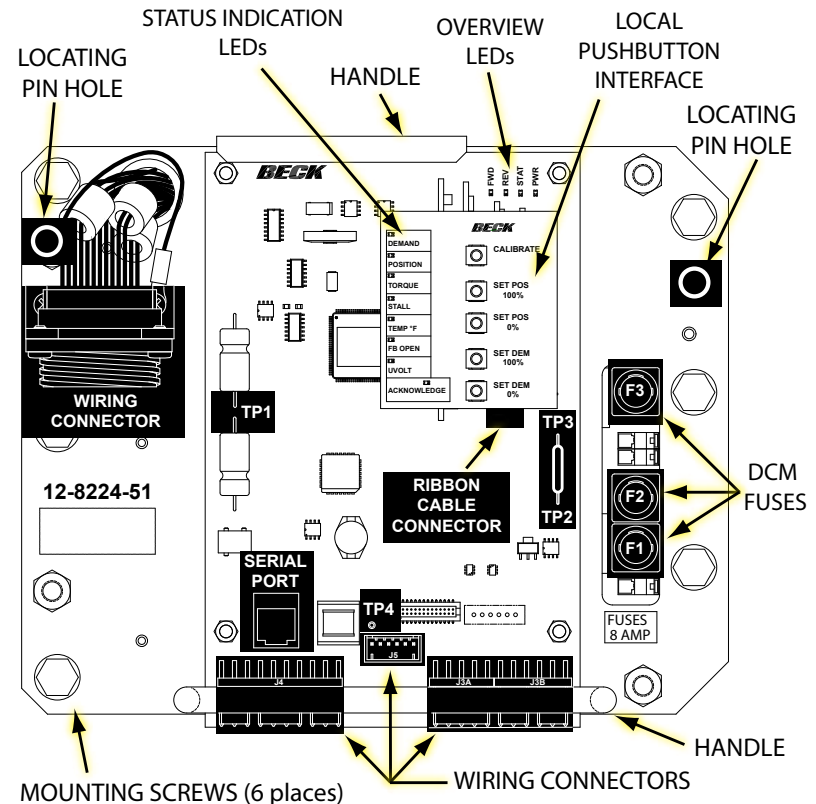
**22-309 DCM-2 CHASSIS****22-409 DCM-2 CHASSIS**

MAINTENANCE

CONTROL END REPLACEMENT

The following procedure describes the steps required to replace the Control End assembly using the control end replacement kit part number 12-8065-05 or -15. The kits include the control end which is comprised of a contactless position sensor (CPS-4), a limit switch assembly, some screws and washers, and a control end gasket for replacement, if necessary.

The replacement control end assembly has been fully calibrated at the factory. This replacement procedure will return the actuator to a close approximation of its original calibration. Do not calibrate the actuator until this procedure is complete, and then only if necessary.

REQUIRED TOOLS

1/2" socket
 3/32" hex driver
 Torque wrenches
 (appropriate for 12 lb-in and 10 lb-ft)
 Fine point marker
 3/16" flat-tipped screwdriver



WARNING

Electrical shock hazard. Disconnect power before proceeding. Remove the actuator from line voltage and disconnect any external power sources feeding the auxiliary switches.

CAUTION

To prevent electrostatic discharge damage to the electronics, wear a grounding strap during this procedure.

PROCEDURE

Remove the old control end assembly:

1. Remove power from the actuator.
2. Remove the control end cover (cylinder shape), using care not to bend the control shaft or damage the position-sensing assembly inside.
3. Disconnect the control end assembly electrical circuits by unplugging the three multi-pin connectors from the actuator. Two connectors lead from the switch subassembly and the other connector leads from the Printed Circuit board. To disconnect the switch subassembly connectors, use a 3/16" flat-tipped screwdriver to press the release tab straight back (see Figure 5) and pull the plug out of its socket. The connector leading from the P.C. board slides off with modest force.
4. Loosen the two outermost setscrews on the coupling. *Do not* loosen the inner setscrews.
5. Use a fine point marker to note the position of the control end relative to the actuator body. Mark the drive's face immediately adjacent to the top of the notch (see Figure 6).
6. Loosen (do not remove) the four mounting clamp button head screws (3/8" long) and slide the top clamp up over the edge of the shoulder in the body, immediately above the stator flange (see Figure 6). Snug one of the screws to hold the clamp up while replacing the assembly. Allow the bottom clamp to hang by the screws.
7. Slide the control end assembly away from the actuator body until it clears the control end shaft.

FIGURE 5.

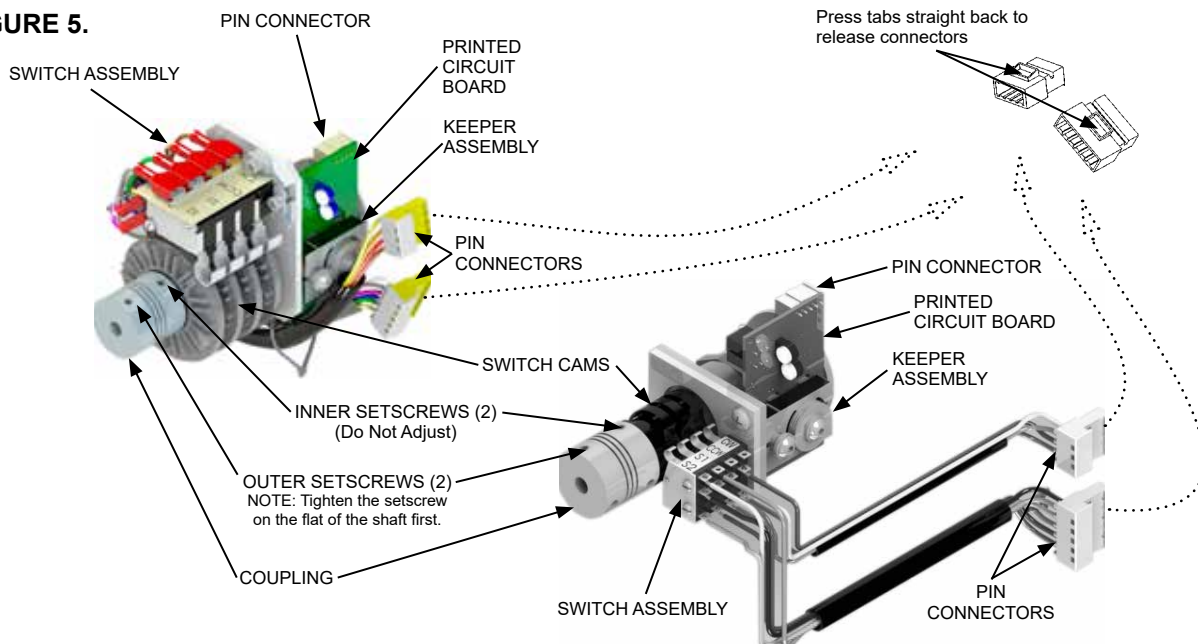

Install the new control end assembly:

1. Inspect the control end gasket and replace as necessary. If the gasket is in good condition and does not require replacement, skip steps 2-6 and go straight to step 7.
2. Protect the CPS-4 with a static-free cover.
3. Clean the mating face of the actuator body to remove any remaining gasket material and adhesive. Use caution not to damage or bend the control shaft. Ensure that the mating surface is free from damage (such as dents or gouges).
4. Peel the backing off the replacement gasket and carefully apply to the actuator body.
5. Remove the protective cover from the CPS-4.
6. Slide the new control end assembly onto the shaft, turning the coupling if necessary to align the assembly with the shaft. Align notch in the stator with the locating pin situated to the left of the control end shaft (see Figure 6).
7. Loosen the clamp screw to allow the top clamp to drop into place over the upper rim of the stator. Rotate the assembly as necessary to align the top of the notch with the mark made earlier on the actuator face. Snug the screws down on the plate. Raise the bottom clamp into position and snug the screws. Check the clamps for proper shoulder clearance and tighten the screws to 12 lb-in (1.3 N•m) torque.
8. Plug the pin connectors into their respective sockets.
9. Tighten the outer 2 setscrews on the coupling. The screw on the flat of the shaft must be tightened first to properly align the assembly. Torque screws to 12 lb-in (1.3 N•m).

Test for proper operation:

1. Connect power to the actuator.
2. Modulate the Demand signal to run the actuator through its full range of motion. Verify the correct actuator response.
3. Modulate the signal to several intermediate levels and note if the actuator attains the proper position.
4. Once proper operation is verified replace the control end cover, tighten the cover bolts to 10 lb-ft (14 N•m) torque, and return the actuator to service.

**FIGURE 6.****Control End Replacement Kit Contents****(P/N 12-8065-05)**

Description	Part Number
Control End Assembly	23-2500-21
Screw (8-32 x 1/2") (4 pieces)	30-0329-35
Flat Washer #8 (4 pieces)	30-0313-31
Lock Washer #8 (4 pieces)	30-0327-20
Control End Gasket	10-8080-02

(P/N 12-8065-15)

Description	Part Number
Control End Assembly	23-2500-52
Screw (8-32 x 1/2") (4 pieces)	30-0329-35
Flat Washer #8 (4 pieces)	30-0313-31
Lock Washer #8 (4 pieces)	30-0327-20
Control End Gasket	10-8080-02

TROUBLESHOOTING

WHERE DO I START?

The Group 22 actuator was designed so the user can quickly diagnose any actuator status conditions causing an interruption in operation. By removing the DCM compartment cover to access the DCM-2, you can view the overview and status indication LEDs. These LEDs provide an efficient means of determining the actuator problem, in many cases without the need for metering equipment.

The following matrix lists some of the potential conditions that a user may experience when troubleshooting.

DCM-2

The DCM-2 board is the control center of the actuator. The DCM-2 has the overview and status indication LEDs that indicate status and alarm conditions. More advanced troubleshooting features may be accessed via HART or serial connection (see respective appendices in this manual). Reference Menu 8, Diagnostics menu, for troubleshooting with HART and for serial port troubleshooting use the diagnostic commands featured in the serial port appendix.

The DCM-2 performs an error based positioning function. It accepts a Demand signal, compares it to an internal position feedback voltage provided by the CPS-4, and controls the motor to correct for a difference. The DCM-2 includes four test points for measuring the Demand and internal position signal voltages at the DCM-2. The Demand signal should measure 1-5 volts DC across test points TP3 (-) and TP2 (+), proportional to the 4-20 mA Demand input signal. The raw position signal should also measure approximately 1 to 5 volts DC across test points TP4 (+) and TP1 (-), proportional to the output shaft's 0-100 degree position (shaft position can be determined by viewing the mechanical index).

CPS-4

The DCM-2 test points noted above should be utilized to measure Demand and internal position signal voltages. If the CPS-4 is not functioning properly, the measurement between TP_COM and VS- should be 40 mV–200 mV, proportional to the 4–20 mA Demand signal. Measurement across TP_COM and 5V should indicate 5 volts.

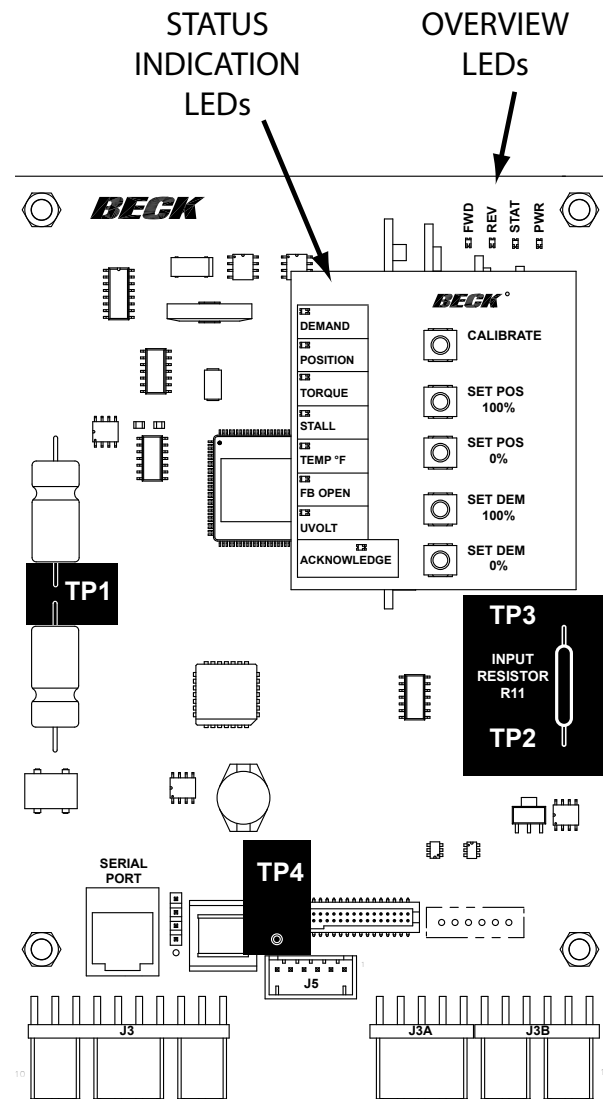

DCM-2 TEST POINTS

Conditions	Possible Causes	Corrections
1. No DCM-2 LEDs are illuminated.	<ul style="list-style-type: none"> a. No power is applied to the actuator. b. Incorrect power is applied to the actuator. c. Main power fuse/breaker is blown. d. DCM-2 malfunction. 	<ul style="list-style-type: none"> a. Apply operating voltage to the operating voltage terminals. b. Verify correct voltage on actuator nameplate and ensure that it is applied at the operating voltage terminals. c. Verify fuse/breaker integrity. Replace/reset if blown. Find cause of short circuit. d. Replace DCM-2.
2. STAT LED is illuminated.	<ul style="list-style-type: none"> a. A status alarm is active. 	<ul style="list-style-type: none"> a. Check the status indication LEDs on the pushbutton interface of the DCM-2. Continue troubleshooting based on the LEDs that are illuminated.
3. DEMAND LED is illuminated.	<ul style="list-style-type: none"> a. No loop-power is present. b. No Demand signal. c. Applied Demand signal is outside of configured range. d. Polarity of applied signal wires is reversed. 	<ul style="list-style-type: none"> a. Restore DC voltage for 2-wire feedback. b. Apply a Demand signal to terminals 14 (-) & 15 (+). c. Confirm Demand signal value via HART or by measuring DC voltage across DCM-2 test points TP3(+) & TP2(-). Should be 1–5 volts for 4–20 mA applied signal. d. Correct the polarity of the applied control signal wires on terminals 14 (-) & 15 (+).
4. POSITION LED is illuminated.	<ul style="list-style-type: none"> a. Position signal voltage generated by CPS-4 read by the DCM-2 is outside of the configured range. b. CPS-4 malfunction. c. DCM-2 malfunction. 	<ul style="list-style-type: none"> a. Using the HART communicator check the Position Sensor Setup menu to verify the Present CPS voltage falls within the configured CPS Zero% and Span (typical range 1–5 volts); OR measure DC voltage between DCM-2 test points TP4 (+) and TP1 (-) to verify Present CPS voltage. If the voltage is outside of 1–5 volts, recalibrate the CPS-4 or replace the control end. b. Replace control end. c. Replace DCM-2.
5. TORQUE LED is illuminated.	<ul style="list-style-type: none"> a. Torque exceeding configured limit (typically over 105% of rated torque) is being applied to the output shaft. b. Torque Null and Torque Constant values are not set correctly. c. Torque cable is not connected to DCM-2. 	<ul style="list-style-type: none"> a. Eliminate cause of excessive torque (i.e., binding damper, improper linkage, etc.). b. Locate Torque Null and Constant values inside DCM compartment and set via HART or Serial port. c. Reconnect torque cable to DCM-2.
6. STALL LED is illuminated.	<ul style="list-style-type: none"> a. Actuator has stalled—unable to achieve desired position within the configured “STALL TIME”. b. The configured stall time is less than the configured Max Travel Time. 	<ul style="list-style-type: none"> a. Eliminate the obstruction and reset the stall by reversing direction on your Demand signal, cycling the power, or issuing the stall reset from HART or Serial command. b. Configure the stall time to exceed the Max Travel Time via HART or Serial command.
7. TEMP F LED is illuminated.	<ul style="list-style-type: none"> a. The measured temperature at the DCM-2 is outside of the normal operating range of -40° to 185° F. 	<ul style="list-style-type: none"> a. Protect the actuator from the extreme temperatures below or above the operating range to eliminate the alarm.

TROUBLESHOOTING

Conditions	Possible Causes	Corrections
8. FB OPEN LED is illuminated.	<ul style="list-style-type: none"> a. There is no external DC power supply connected to terminals 22 (-) and 24 (+). b. The optional actuator powered feedback circuit is open. 	<ul style="list-style-type: none"> a. Apply DC power to feedback circuit. b. If not using the 4-20 mA feedback at terminals 16(-) and 17(+), install a jumper or resistor (800 ohm max.) between those terminals.
9. UVOLT LED is illuminated.	<ul style="list-style-type: none"> a. The applied operating voltage is outside of the tolerance (+10%/-15%) of the nameplate operating voltage. b. A DCM-2 fuse is open (or primary transformer fuse on 22-809 is open). c. A component failure has occurred on the DCM-2. 	<ul style="list-style-type: none"> a. Apply the correct operating voltage to the actuator per the voltage stamped on the nameplate. b. Replace the open fuse with the appropriate fuse kit; see page 15. c. Replace the DCM-2.
10. All LEDs are illuminated or flashing.	<ul style="list-style-type: none"> a. A component failure has occurred on the DCM-2. 	<ul style="list-style-type: none"> a. Replace the DCM-2.
11. The actuator will only move at a very slow speed when using the Handswitch or override terminals.	<ul style="list-style-type: none"> a. The DCM-2 does not detect a valid position signal from the CPS-4. b. The actuator max travel time is set to a high value (maximum allowable time is 300 seconds). 	<ul style="list-style-type: none"> a. Check loop-power. Verify CPS-4 cable connections, check CPS-4 reading between PC board points TP COM & VS- for 40-200 mV, check CPS-4 power supply for 5 volts DC between TP COM and V5. Replace control end if necessary. b. Adjust max travel time via HART or Serial closer to the minimum (30 seconds for 22-309 and 15 seconds for 22-409).
12. FWD or REV LED is illuminated, actuator is not moving, and there are no other status alarms.	<ul style="list-style-type: none"> a. Handswitch is in the STOP position. b. CW or CCW limit switch is open. 	<ul style="list-style-type: none"> a. Turn the Handswitch to the AUTO position. b. Verify limit switch is set outside of electrically calibrated limits & readjust or replace, if necessary.
13. Actuator runs uncontrolled to one end of travel.	<ul style="list-style-type: none"> a. The CPS-4 is malfunctioning. b. The DCM-2 is malfunctioning. 	<ul style="list-style-type: none"> a. Verify CPS-4 cable connections, check CPS-4 reading between PC board points TP COM & VS- for 40-200 mV, check CPS-4 power supply for 5 volts DC between TP COM and V5. Replace control end if necessary. b. Verify the raw position signal seen by the DCM-2 at test points TP4 and TP1 for 1 - 5 volts DC. If valid signal is measured, replace DCM-2.
14. Actuator will not hold position with Handswitch in STOP.	<ul style="list-style-type: none"> a. Self-Locking Mechanism (SLM) is damaged. 	<ul style="list-style-type: none"> a. Rebuild the SLM assembly.
15. Actuator PWR LED is flashing, but does not respond to Demand signal, Handswitch or override terminals.	<ul style="list-style-type: none"> a. The emergency override STOP terminal (21) is connected to the common terminal (18). b. The safety shutoff circuit is damaged. c. The Handswitch is damaged. 	<ul style="list-style-type: none"> a. Remove the connection from terminal 21 to terminal 18. b. Contact the factory. c. Replace the Handswitch.
16. HART communications cannot be established with the DCM-2.	<ul style="list-style-type: none"> a. The Device Description (DD) file is not installed. b. The HART communicator is not compatible with Beck equipment. c. The HART communications circuit on the DCM-2 is damaged. 	<ul style="list-style-type: none"> a. Install the Beck MK-2 DD on your HART device. b. Utilize a compatible HART communicator or configure the actuator through the Serial port. c. Replace the DCM-2.

Conditions	Possible Causes	Corrections
17. Present CPS voltage appears to be within the configured range, but the position Feedback signal at terminals 16 and 17 remains constant or erratic.	a. The position feedback circuit on the DCM-2 is damaged.	a. Replace the DCM-2
18. Power LED is pulsing bright to dim.	a. This is a normal condition indicating the processor is functioning.	a. No action required.
19. Output shaft rotates opposite of desired direction when applying a 4–20 mA Demand signal.	a. The rotation direction is incorrectly configured.	a. Configure the rotation direction using pushbutton, HART, or serial method (page 26).

APPENDIX HART® *Communication*

The DCM-2 board is the control center of the actuator. actuator configuration and calibration are accessed and set through the DCM-2 board. Using the HART interface requires a HART compatible communicator that contains files specifically created to communicate with the Beck actuator. Beck-written Device Description Language Files (DDL) are certified by the HART Communications Foundation. Communicators such as the 375 and 475 use these files to access the Group 22 features. Other communicators that utilize alternative file formats (DOF for example) may be commercially available, but rely on third party software that is not directly supported by Harold Beck and Sons, Inc.

This instruction manual supports Group 22 actuators built with DCM-2 part numbers 12-8224-41, 12-8224-45, 12-8224-51, and 12-8224-55, and describes how to access features using the HART Communicator.

USING THE 375 OR 475 COMMUNICATOR

HART communicators require that the field device manufacturer's DD files be installed to access device specific features. This can be checked before connecting to the actuator. Turn on the communicator, select "Offline", then "New Configuration." Scroll to HAROLD BECK AND SONS, and verify that BECK-MK2 is installed. If it is not, contact the communicator supplier or Beck for instructions on how to update the communicator.

The communicator leads should be connected to any of the acceptable communicator connection points detailed on the following page. This allows the communicator to simultaneously communicate over the analog input wires, but does not disturb the analog command signal or disrupt the DCM-2 functions. However, any program changes to the DCM-2 will momentarily suspend the operation of the module (maintains last state) while the change is implemented. Typically, this is only for a second or two.

With the communicator connected, turn on the communicator and wait for communications to be established. Once communicating, the "Online" display will appear in the communicator window. If applicable, select the "HART application" option to access the online menu. If the actuator is multidropped with other devices on a single HART network, the first display screen will list all devices and require a selection before the "Online" display is shown. The "Online" display provides online information about the present actuator operating conditions. Entering any of the menus shown in the

menu structure is accomplished by following the display and using the communicator's arrow keys. If the communicator is unable to communicate with the DCM-2, it will display the message, "No Device Found". If this occurs, ensure that the communicator is securely connected to any of the acceptable communicator connection points, and retry. If communications still do not occur, the communicator polling setup may be improperly set. Check the "utility" menu and make sure communications polling is set to "always poll".

The communicator keypad and display is shown on the following page.

The LCD displays all the information and actions available.

The function keys and on-screen buttons are used to perform certain actions such as entering settings, accessing help screens, sending commands, paging up and down within methods, and exiting methods. The function of each key/button may change depending on the menu or method selected. As functions change, so do the dynamic labels in the LCD.

The arrow keys on the communicators allow movement between menus as shown in the menu structure.

The alphanumeric keys are used to type in entries. Whenever a selected menu or method requires a value or description to be entered, this keypad is used. Since each key represents four different characters, three shift keys are provided at the bottom of the pad.

Before moving on, it may be helpful to practice with the communicator. Connect the communicator as described, turn it on and establish communications. Then use the arrow keys to move through the various menus as shown in the menu structure.

HART INTERFACE

This appendix includes the menu structure for communicating with a DCM-2 using a HART Handheld Field communicator. It shows all the possible setup options, features and available information. If a particular feature is not available, a message to that effect will be displayed when an attempt to access or change the feature is made.

HANDHELD COMMUNICATORS



MODEL 375



MODEL 475

ACCEPTABLE COMMUNICATOR CONNECTION POINTS

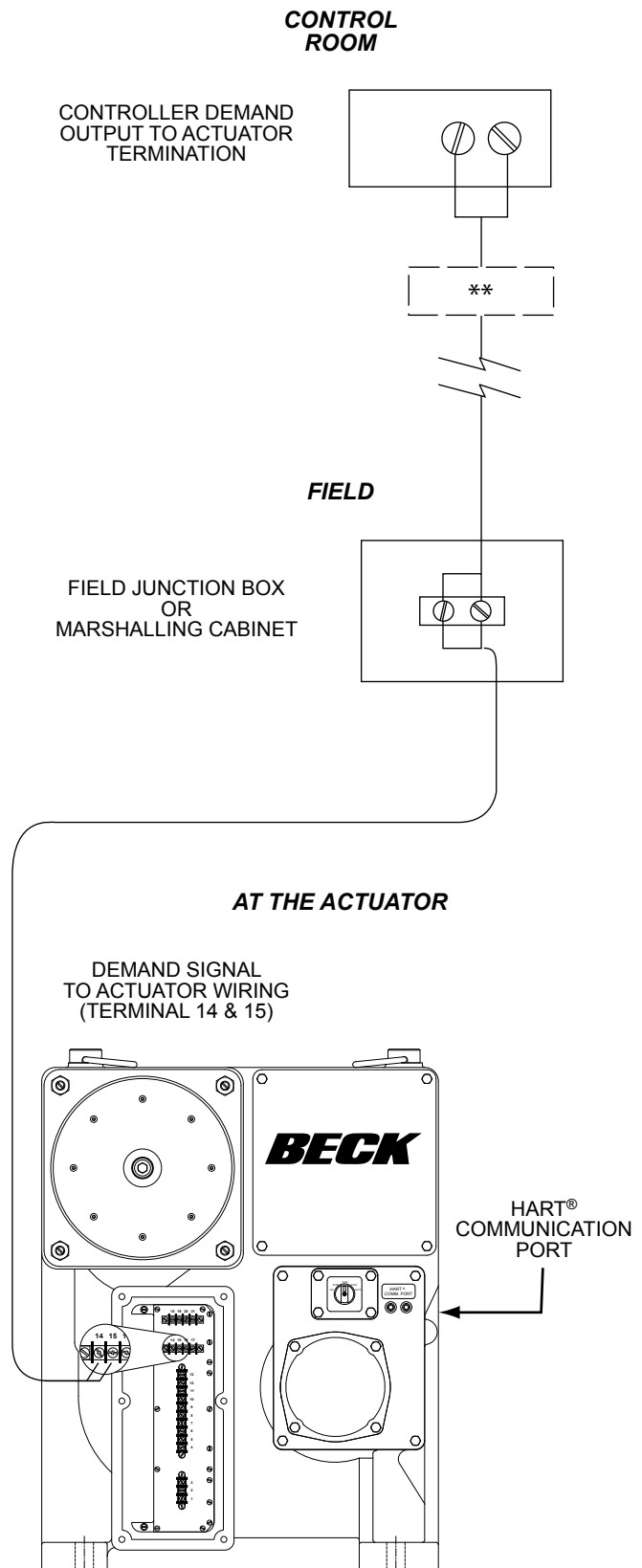

** A 250 ohm load resistor may be required for proper HART communication when the DCM-2 has been modified for 1-5 VDC Demand signal operation.

APPENDIX HART® Communication

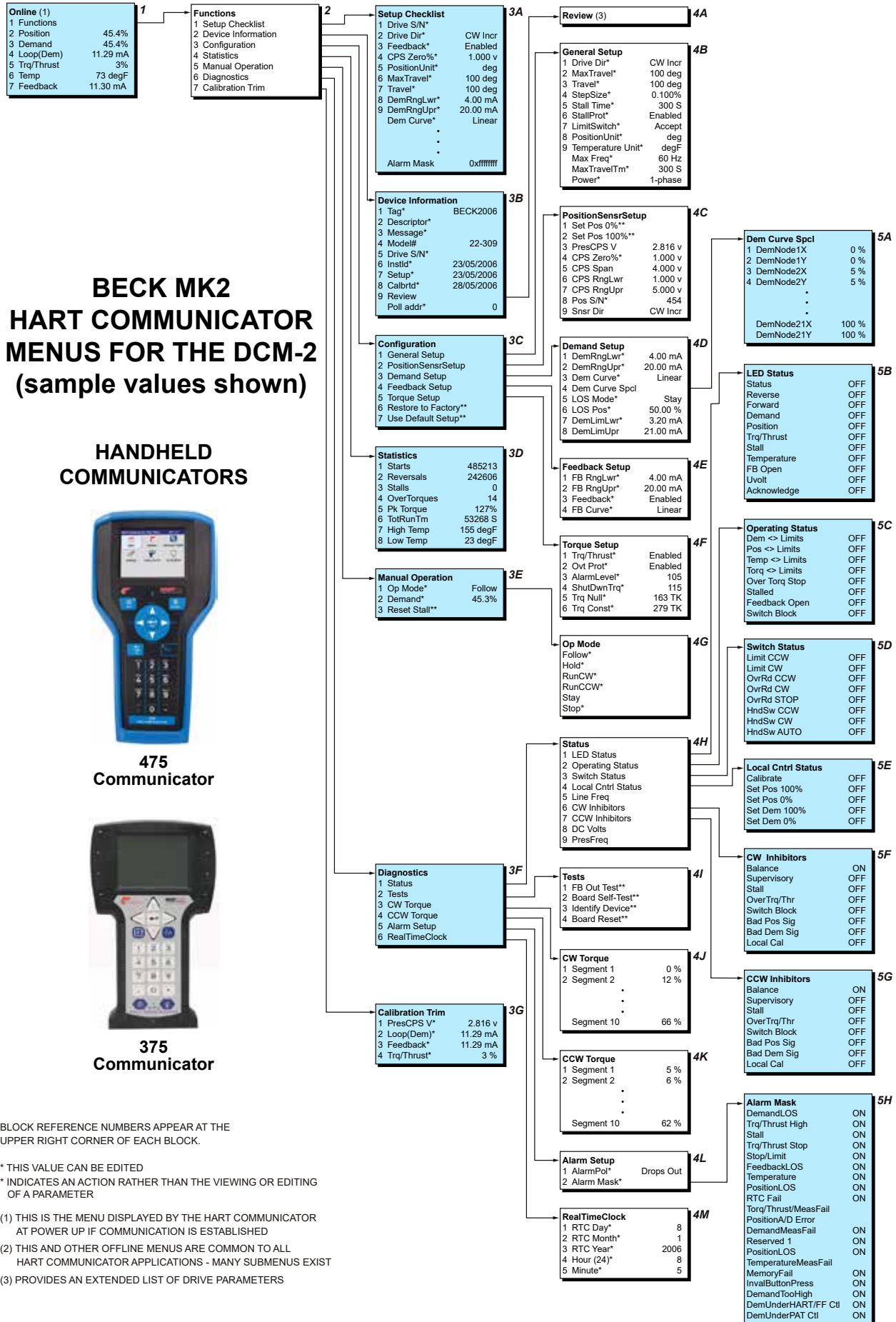

BLOCK REFERENCE NUMBERS APPEAR AT THE UPPER RIGHT CORNER OF EACH BLOCK.

* THIS VALUE CAN BE EDITED

** INDICATES AN ACTION RATHER THAN THE VIEWING OR EDITING OF A PARAMETER

- (1) THIS IS THE MENU DISPLAYED BY THE HART COMMUNICATOR AT POWER UP IF COMMUNICATION IS ESTABLISHED
- (2) THIS AND OTHER OFFLINE MENUS ARE COMMON TO ALL HART COMMUNICATOR APPLICATIONS - MANY SUBMENUS EXIST
- (3) PROVIDES AN EXTENDED LIST OF DRIVE PARAMETERS

MENU DESCRIPTIONS

(See HART Communicator Menu on page 52)

MENU 1 -- Online

When communications are established with the communicator, the Online menu is displayed.

- 1 Functions:** The link to the menu tree.
- 2 Position:** The output shaft position displayed as a percent of range.
- 3 Demand:** The Demand signal displayed as a percent of range.
- 4 Loop (Dem):** The Demand signal measured in mA.
- 5 Trq/Thrust:** The present torque value as applied to the output shaft (optional).
- 6 Temp:** The ambient temperature of the DCM-2.
- 7 Feedback:** The mA output signal representing the present position of the output shaft.

MENU 2 -- Functions

From the Functions menu, any of the DCM-2 functional menus can be selected and accessed. There are seven functional areas: Setup Checklist, Device Information, Configuration, Statistics, Manual Operation, Diagnostics, and Calibration Trim.

MENU 3A -- Setup Checklist

The Setup Checklist provides a quick way for the user to setup the most important items necessary for basic actuator operation without having to move through multiple sub-menus. These items are defined on the following pages in their specific menu locations.

MENU 3B -- Device Information

The Device Information menu provides information about the actuator. There are ten useful information entries that may be viewed and/or edited.

- 1 Tag:** An 8 character entry that can be used to identify a specific field device label.
- 2 Descriptor:** A 16 character field that can be used to provide any description desired.
- 3 Message:** A 32 character field that can be used to provide any message desired.
- 4 Model#:** Displays the model number of the actuator in which the DCM-2 is installed. This field may be edited. Note that changing this field may cause the "Use Default Setup" command to not function.

- 5 Drive S/N:** The Serial number as shown on the actuator nameplate. When configured, this will automatically change the actuator model number (see previous item).

- 6 Instld:** Installation date of the actuator or DCM-2.

- 7 Setup:** The setup date has no affect on actuator operation.

- 8 Calbrtd:** The calibration date has no affect on actuator operation.

- 9 Review:** Link to the Review menu.

- 10 Poll addr:** Used to find the actuator. Most configurations should use "0".

MENU 4A -- Review

The Review menu displays many of the configured parameters in a read-only format. This menu may help ensure that the DCM-2 is configured as desired.

MENU 3C -- Configuration

The Configuration menu serves as the gateway to all of the actuator operating parameters that can be used to configure the actuator based on the desired operation.

- 1 General Setup:** Link.

- 2 PositionSensrSetup:** Link.

- 3 Demand Setup:** Link.

- 4 Feedback Setup:** Link.

- 5 Torque Setup:** Link.

- 6 Restore to Factory:** Restores field-configurable parameters back to the settings in effect when the DCM-2 was shipped from the factory.

- 7 Use Default Setup:** Changes the DCM-2 position sensing voltage ranges to the proper ranges for the actuator model.

MENU 4B -- General Setup

This menu sets actuator operating parameters. The nine parameter entries are as follows:

- 1 Drive Dir:** The direction the output shaft rotates (looking into the output shaft) in response to an increasing Demand signal.

- 2 MaxTravel:** The maximum available travel distance of the output shaft in degrees. This number corresponds to the actuator design—if the correct Serial Number is entered, this parameter is set to 100° and should not be changed.

APPENDIX HART[®] Communication

MENU 4B -- General Setup (cont'd)

- 3 Travel:** The number of degrees of output shaft travel for 100% span (60–100°).
- 4 StepSize:** The smallest Demand change that will cause an output shaft movement (0.1%–2.5%).
- 5 Stall Time:** The amount of time the motor will run (30–300 seconds) before Stall Protection is initiated and power disabled to the motor.
- 6 StallProt:** This entry is set as either “Enabled” or “Disabled”.
- 7 LimitSwitch:** This entry is set as either “Accept” or “Alert” and defines whether or not contacting an overtravel limit switch outside of the normal 0% to 100% travel range will cause an alarm condition.
- 8 PositionUnit:** The numeric unit of measure for the output shaft position in angular degrees.
- 9 Temperature Unit:** The unit of measure for temperature sensing. May be “degF” (fahrenheit) or “degC” (celsius).
- 10 Max Freq:** Maximum allowed motor power frequency. This is factory set and should not be changed.
- 11 MaxTravelTm:** The time required for the actuator to travel (100°) between the limits. Model 22-309 is configurable between 30–300 seconds; models 22-409/-809 are configurable between 15–300 seconds.
- 12 Power:** Model 22-309 actuators are configured for “1-phase”; 22-409/-809 are configured for “3-phase”.

MENU 4C -- PositionSensrSetup

This menu contains parameters that determine how the DCM-2 interprets the output shaft position signal from the CPS-4.

- 1 Set Pos 0%:** Sets the 0% position to match the present output shaft position. This does not change the 100% position.
- 2 Set Pos 100%:** Sets the 100% position to match the present output shaft position. Also instructs the DCM-2 to change travel span based on the 0% position. This does not change the 0% position.
- 3 PresCPS V:** Displays the CPS-4 signal voltage at the present output shaft position. Not editable.
- 4 CPS Zero%:** Displays the CPS-4 voltage at the 0% output shaft position. May be edited to define the voltage at the lowest operating point of travel. For CW actuator

configuration, this voltage should be 1.3 V and for CCW configuration, 3.7 V. The DCM-2 will automatically adjust when the direction of travel is changed.

- 5 CPS Span:** Displays the voltage signal span from the CPS-4 for maximum possible rotation of the output shaft. This is the upper range voltage minus the lower range voltage (typically 2.4 V). Not editable.
- 6 CPS RngLwr:** Displays the CPS-4 voltage signal at the lowest possible point of travel. Not editable.
- 7 CPS RngUpr:** Displays the CPS-4 voltage signal at the highest possible point of travel. Not editable.
- 8 Pos S/N:** Displays the Serial number of the CPS-4 and has no effect on actuator function.
- 9 Snsr Dir:** The direction of output shaft rotation that causes the CPS-4 signal to increase. This direction is typically CW and is not editable.

MENU 4D -- Demand Setup

The parameters on this menu determine the range and characterization of the Demand signal. It also includes parameters that determine behavior when the Demand signal is absent.

- 1 DemRngLwr:** Sets and displays the signal value in mA that represents 0% Demand (default is 4.00 mA, minimum is 0.5 mA). This value should be set above “DemLimLwr”.
- 2 DemRngUpr:** Sets and displays the signal value in mA that represents 100% Demand (default is 20.00 mA, maximum is 21.00 mA). This value should be set below “DemLimUpr”.
- 3 Dem Curve:** Determines the relationship between the Demand signal and the position of the output shaft. Typically set to Linear, but may also be set to Square, Square Root or customized Special Curve.
- 4 Dem Curve Spcl:** Link to the “Dem Curve Spcl” menu.
- 5 LOS Mode:** Action on loss of Demand signal.
- 6 LOS Pos:** If the “LOS Mode” has been set to “Go-to-Pos”, this defines where the output shaft will move (in percent of travel) during loss of Demand signal conditions.
- 7 DemLimLwr:** Sets the threshold (in mA) below which the Demand signal is considered lost. This value should be set below “DemRngLwr”.
- 8 DemLimUpr:** Sets the threshold (in mA) above which the Demand signal is considered invalid. The Demand alarm will activate until

the signal is brought below this level. This value should be set above "DemRngUp".

MENU 5A -- Dem Curve Spcl

This menu allows setting the Demand signal characterization curve.

MENU 4E -- Feedback Setup

This menu is where all the Feedback signal related actuator parameters are set.

- 1 FBRngLwr:** The value of the Feedback signal (in mA) that corresponds to a 0% output shaft position. This value can range between 3.00 mA and 16.00 mA (default = 4.00 mA).
- 2 FBRngUp:** The value of the Feedback signal (in mA) that corresponds to a 100% output shaft position. This value can range between 7.00 mA and 21.00 mA (default = 20.00 mA).
- 3 Feedback:** Enables or Disables the Feedback signal.
- 4 FB Curve:** Allows a choice in the relationship between the applied Feedback signal and the actual position of the actuator. Choices are: Linear & Inverted Demand ("InvDem").

MENU 4F -- Torque Setup

This menu is where all the Torque related actuator parameters are set.

- 1 Trq/Thrust:** Enables or disables torque sensing.
- 2 Ovt Prot:** Enables or disables overtorque protection which will remove power from the motor if excessive torque is detected.
- 3 AlarmLevel:** Sets the value that, if exceeded, will cause the Torque Alarm to activate (20–105%).
- 4 ShutDwnTrq:** Sets the output shaft torque in percentage of actuator rating that, if exceeded, removes power from the motor (25–115%).
- 5 Trq Null:** The torque sensor value that represents 0% output shaft torque. This value is unique for each actuator and may be found on a label inside the DCM compartment.
- 6 Trq Const:** The internal DCM-2 signal span associated with the output shaft torque. This value is determined during manufacture and is noted on a label inside the DCM compartment.

MENU 3D -- Statistics

This menu is where all the actuator's stored operating statistics are available.

- 1 Starts:** The total number of motor starts.
- 2 Reversals:** The total number of times the motor has started in the direction opposite to the previous start.
- 3 Stalls:** The total number of times the stall time has been exceeded.
- 4 OverTorques:** The total number of times that excessive torque was detected at the output shaft.
- 5 Pk Torque:** The highest recorded torque on the output shaft.
- 6 TotRunTm:** Total amount of time the motor has been powered (in seconds).
- 7 High Temp:** Highest temperature recorded in the DCM-2 compartment (in degrees fahrenheit).
- 8 Low Temp:** Lowest temperature recorded in the DCM-2 compartment (in degrees fahrenheit).

MENU 3E -- Manual Operation

This menu is used to allow manual operation using HART® communications. There are three manual operation procedures available:

- 1 Op mode (Menu 4G):** Selects the operating mode of the DCM-2. There are six possible choices: "Follow", "Hold", "RunCW", "RunCCW", "Stay" and "Stop". "Follow" mode is the normal state of operation and allows the DCM-2 control in response to the analog input Demand signal. "Hold" mode forces the DCM-2 to position according to the HART Demand value (see right). "RunCW" mode forces the actuator to move CW. "RunCCW" forces the actuator to move CCW. The "Stay" mode forces the actuator to maintain its present position. Note that in "Stay" mode, the Handwheel cannot be freely turned. The "Stop" mode removes power from the motor. Note that in "Stop" mode the Handwheel can be freely turned. Note that the Handswitch overrides all operating modes.
- 2 Demand:** This procedure sets the effective Demand signal. If "Op mode" is set to "Hold", entering a valid value (-5% to 105%) will control the motor. If "Op mode" is set to "Follow", the analog Demand signal is displayed (unless an alarm condition exists).
- 3 Reset Stall:** This procedure resets normal actuator operation after a stall condition has caused the motor to shut down. Note that stall conditions can also be reset by simply reversing the input Demand signal or cycling the actuator AC power.

APPENDIX HART[®] Communication

MENU 3F -- Diagnostics

Provides paths to menus that allow investigation of actuator problems through status indicators, self-test routines, output shaft loading history, alarm setup and setting of the DCM-2 real time clock. Menu item links are "Status", "Tests", "CW Torque", "CCW Torque", "Alarm Setup", and "RealTimeClock".

MENU 4H -- Status

This menu provides links to menus that monitor the operational status of the actuator. It also displays one parameter, line frequency.

5 Line Freq: The power line frequency as measured by the DCM-2.

MENU 5B -- LED Status

The LED Status parameter allows remote checking of which LEDs on the DCM-2 are illuminated.

MENU 5C -- Operating Status

The Operating Status parameter is a summary of whether process-related conditions are inside or outside of anticipated limits. These conditions control the Status Indication LEDs. Each parameter is listed with an ON or OFF state. The ON state is described below.

- 1 Dem <> Limits:** Caused by the Demand signal falling below or above acceptable levels.
- 2 Pos <> Limits:** Caused by the CPS-4 signal being outside the range anticipated by the DCM-2.
- 3 Temp <> Limits:** The ambient temperature of the DCM-2 is outside of the rating.
- 4 Torq <> Limits:** Measured torque exceeds the configured alarm level.
- 5 Over Torq Stop:** Overtorque protection is preventing the DCM-2 from running the motor.
- 6 Stalled:** A Stall alarm is active.
- 7 Feedback Open:** The Feedback signal is enabled, but cannot follow the proper current.
- 8 Switch Block:** The DCM-2 cannot power the motor due to an electro-mechanical switch. Check the Handswitch and over-travel limit switches.

MENU 5D -- Switch Status

Each parameter will be listed with an ON or OFF state. The ON state is described below.

Limit CCW: The CCW over-travel limit switch has been reached.

Limit CW: The CW over-travel limit switch has been reached.

OvrRd CCW: The CCW manual override terminal (20) is shorted to the common (18).

OvrRd CW: The CW manual override terminal (19) is shorted to the common (18).

OvrRd STOP: The STOP manual override terminal (21) is shorted to the common (18).

HndSw CCW: The handswitch is in the CCW position.

HndSw CW: The handswitch is in the CW position.

HndSw AUTO: The handswitch is in the AUTO position.

MENU 5E -- Local Cntrl Status

This parameter allows remote monitoring of which buttons on the local configuration interface are being pressed.

MENU 5F -- CW Inhibitors

Allows viewing of the DCM-2 condition that is preventing the actuator motor from running in the CW direction.

MENU 5G -- CCW Inhibitors

Allows viewing of the DCM-2 condition that is preventing the actuator motor from running in the CCW direction.

MENU 4I -- Tests

This menu provides access to some routines that help determine if the actuator is functioning properly.

- 1 FB Out Test:** Allows manual verification of the Feedback output signal to check operation and accuracy.
- 2 Board Self-Test:** Instructs the DCM-2 to check various power and sensing circuits. This test will cause the actuator to reposition, so it should be run offline and only when a DCM-2 problem is suspected.

3 Identify Device: Causes the ACKNOWLEDGE LED on the DCM-2 to flash for two seconds. Ensures the HART system is addressing the correct actuator.

4 Board Reset: Causes the DCM-2 to initiate a reset cycle similar to a power-up reset. This manual reset will cause the actuator to reposition. This procedure is not typically necessary.

MENU 4J -- CW Torque

This menu displays the peak output shaft torque measured for 10 segments. These torque values are measured with the motor running and moving the output shaft CW.

MENU 4K -- CCW Torque

This menu displays the peak output shaft torque measured for 10 segments. These torque values are measured with the motor running and moving the output shaft CCW.

MENU 4L -- Alarm Setup

The Alarm Setup menu parameters allow modification of the behavior of the alarm.

1 AlarmPol: Whether the solid state relay opens on alarm or closes on alarm.

2 Alarm Mask: Link to the Alarm Mask menu which allows specific alarm conditions to be ignored.

MENU 5H -- Alarm Mask

Allows selection of alarm conditions that will not cause an alarm at terminal E.

MENU 4M -- RealTimeClock

This menu allows the date and time to be set.

1 RTC Day: Day of the month (numeric value).

2 RTC Month: Month (numeric value).

3 RTC Year: Year (4 digits).

4 Hour (24): Hour of the day (24 hour format).

5 Minute: Minute of the hour (0 through 59).

MENU 3G -- Calibration Trim

The Calibration Trim menu sets and displays actuator calibration values. **Note that changing the calibration trim can cause signal measurement difficulties if performed improperly.**

1 PresCPS V: Displays and/or trims the present voltage of the position signal. This value may also be measured at DCM-2 test points TP1(-) and TP4(+). This trim is set and tested at the factory. Changing this value can cause voltage measurement errors.

2 Loop(Dem): Displays the Demand signal as measured at the field wiring terminals (14 & 15). When the Demand control loop signal is being overridden by a special mode of operation, the effective Demand will not correspond to the mA value. This value can be edited to trim the Demand to ensure accurate measurement of the analog signal. Demand can only be trimmed at 4.0 mA and 20.0 mA.

3 Feedback: Displays the mA signal representing the output shaft position as measured at the field wiring terminals (16 & 17). This value can be edited.

4 Trq/Thrust: Displays the load measured at the output shaft as a percentage of rated torque. This is also a short cut to set the 0% torque parameter ("Trq Null") by removing load from the output shaft, then setting this value to "0".

APPENDIX HART® Messages

COMMON HART® MESSAGES

HART® protocol maintains both standard and device specific informational messages that are displayed on the Communicator when various conditions occur.

Below is a table of typical Beck actuator messages and message sequences. It does not include all possible messages, only the most common followed by a brief description.

Output Shaft Position Measurement Messages

Message	Description
"Process applied to the primary variable is outside the operating limits of the field device."	This is a standard HART-defined message that appears whenever the Position signal from the CPS-4 is outside the design or calibrated range. This message should be accompanied by a Beck-specific message with more detail.
"The Position Signal is less than -5% or greater than 105%."	This Beck-specific message indicates the DCM-2 is reading a CPS-4 Position signal not within the calibration range limits.
"Position signal in LOS."	This is a Beck-specific message. The DCM-2 is indicating that the Position signal is a problem and is intended to identify a CPS-4 or wiring failure. This is triggered when the Position signal is outside the minimum and maximum voltage limits.
"Position out of accurate measurement range."	This is a Beck-specific message. The DCM-2 indicates the CPS-4 Position signal is outside of the design range.
"Position sensing error."	This is a Beck-specific message. The DCM-2 circuitry for measuring the Position signal does not appear to be functioning properly.
"Analog output 1 and its digital representation are outside the operating range limits, and not responding to input."	This is a standard HART-defined message that appears whenever the position signal to the DCM-2 is outside the design or calibrated range. This message should be accompanied by a Beck-specific message with more detail.

Handswitch and Over-travel Limit Switch Message

Message	Description
"Motor power is blocked, check switches."	This message will appear if the DCM-2 detects a condition that prevents current flow to the motor.

Stall Protection Message

Message	Description
"Stall condition has been detected (see 'Stall Time' in the 'General Setup' menu 4B)."	This is a Beck-specific message indicating that the actuator is in a stalled condition. This occurs if the actuator cannot reach the Demand position in the time allotted by the stall time setting (configurable from 30–300 seconds).

Demand, Torque and Temperature Measurement Messages

Message	Description
"Process applied to the non-primary variable is outside the operating limits of the field device."	This is a standard HART-defined message that appears whenever the Demand signal or Temperature are outside their design or calibrated ranges. This message should be accompanied by a Beck-specific message with more detail.
"The Demand Signal is outside of the intended limits (see Demand Setup menu 3C)."	This Beck-specific message indicates the Demand signal is invalid.
"Demand out of accurate measurement range."	This is a Beck-specific message that the Demand signal is not only out of the calibrated range, but also out of the design range of the actuator. The lower and upper limits are 0.1 V dc and 5.5 V dc, respectively. Note that current input DCM-2 boards utilize a 250 Ohm input resistor to convert the current signal to voltage.
"Demand Signal is out of limit."	This Beck-specific message indicates the Demand signal is too high to measure accurately. The upper limit is 5.5 V dc. Note that current input DCM-2 boards utilize a 250 Ohm input resistor to convert the current signal to voltage.
"Demand sensing error."	This is a Beck-specific message. The Demand sensing circuitry does not appear to be functioning properly.
"The Torque/Thrust is greater than the output rating."	This Beck-specific message defines an output shaft torque overload problem.
"Motor power has been removed due to excessive output torque."	This Beck-specific message indicates the DCM-2 has removed power from the motor due to excessive output shaft torque load. The Handswitch must be in AUTO mode for this alarm to be accurate.
"Torque/Thrust out of accurate measurement range."	This is a Beck-specific message. The DCM-2 is not able to read a valid signal from the Torque sensor. Check the torque sensing cable.
"Torque/Thrust sensing error."	This is a Beck-specific message. The DCM-2 circuitry for measuring the Torque signal does not appear to be functioning properly. Check the torque sensing cable.
"The temperature is outside of -40°F to 185°F."	This is a Beck-specific message indicating that the temperature at the DCM-2 is outside of the acceptable range.
"Temperature out of accurate measurement range."	This is a Beck-specific message. The DCM-2 ambient temperature reading is extreme and cannot be accurately measured.
"Temperature A/D Fail."	This is a Beck-specific message. The DCM-2 circuitry for measuring the ambient temperature does not appear to be functioning properly.
"The Feedback Signal is enabled but the loop is open."	This is a Beck-specific message indicating that the Feedback sourcing circuit is unable to create the proper signal current. This message could result from the signal not being wired to an external load, or a wiring failure has occurred at some point between the actuator and the monitoring device.

APPENDIX HART[®] Messages

Questionable Configuration Messages

Message	Description
"Analog output 1 and its digital representation are in fixed mode, and not responsive to input changes."	Standard HART-defined message that appears whenever the Feedback signal has been manually assigned a value. This message should be accompanied by a Beck specific message with more detail.
"Feedback is in fixed mode."	A Beck-specific message indicating that the Feedback signal has been manually set to a fixed value and is not following the Position value.
"Local control button pressed while locked-out."	A Beck-specific message indicating an incorrect combination of pushbuttons is being pressed on the local configuration interface, or the local control interface is disabled and a pushbutton is being pressed.
"Loop Current Detected while under HART/FF Control."	A Beck specific alarm message that alerts the user that analog current is present on the Demand terminals, but the DCM-2 is in an Op Mode expecting digital control. Make certain the Op Mode parameter is set properly.
"Loop Current Detected while set for LOS PAT."	A Beck specific alarm message that alerts the user that analog current is present on the Demand terminals, but the DCM-2 is set to a LOS mode intended to be used without an analog signal.

DCM-2 Failure Messages

Message	Description
"Real-time Clock hardware failure."	This is a Beck-specific message. The data in the Real-time Clock appears invalid.
"FRAM Memory has failed."	A Beck-specific message. The continuous built-in self-test cannot verify the memory for statistics information is operating properly.
"Memory failure."	This is a Beck-specific message. The continuous built-in self-test cannot verify the microcomputer is operating properly.

Miscellaneous HART-Defined Messages

Message	Description
"Field device has more status available."	This is a standard HART-defined message that appears whenever an alarm or other undesirable status exists. This is the HART protocol mechanism for displaying the other messages in this section. If this message is displayed without an additional message, the status cleared before HART read the additional status.
"A reset or self-test of the field device has occurred, or power has been removed and reapplied."	This message is presented if the DCM-2 has gone through a power-up reset sequence since the last communication with the master. This message is only displayed once after a reset.
"A modification has been made to the configuration of the field device."	This message indicates that the DCM-2 has undergone a configuration change since the last time the HART master has reset the change flag. Many HART masters disregard the flag and do not report this message.
"Field device has malfunctioned due to a hardware error or failure."	This message indicates that the continuous built-in self-test cannot verify the microcomputer is operating properly.

APPENDIX *Serial Communication*

COMMUNICATIONS

Local configuration of the Beck actuator can be accomplished using Serial commands through the DCM-2 Serial port.



CAUTION

Changes made to the actuator through Serial communications may not necessarily be reflected in asset management systems. Be sure to verify any changes made serially and make manual corrections to the asset management system if necessary.

The Beck Digital Control Module (DCM-2) is equipped with a Serial interface which allows for direct communication with a computer. Using a communication cable (see illustration on page 63), connect the DCM-2 to the computer using the DCM-2's RS-232 (J20) connector (see page 21 for port location) and the computer's COM port. Ensure that the COM port on the computer is active, and that the cable is plugged into the proper COM port if more than one is present (e.g., COM1, COM2, etc.). Note that a plug end adapter may be necessary for connection to the computer's COM port.

Once connected, communication can be established between the DCM-2 and the computer using a terminal emulation program, such as HyperTerminal®. This method of communication will allow for configuration, calibration and verification of actuator DCM-2 settings without the use of custom software applications.

HyperTerminal® SOFTWARE

HyperTerminal is the standard ASCII terminal emulation software provided with Microsoft® Windows®. If using HyperTerminal®, the following instructions will assist in setup and assume use of the Beck Serial cable (see following page). Note that some variation to these instructions may be necessary depending on the version of HyperTerminal® being used.

The RJ-11 connector (on the Beck Serial cable) should be attached to the RS-232 port on the DCM-2 (see page 21). The other end of the Beck Serial cable (the DB-9 connector) should then be plugged into a windows-based computer. Some computers may require a Serial adaptor such as a USB/Serial converter to communicate.

Access HyperTerminal® by clicking first on "Start", then "Programs", then "Accessories", then "Communications", then "HyperTerminal". Double-click on the "Hypertrm.exe" icon to start the program. Once HyperTerminal® is running, it is necessary to set up a file with the proper settings to communicate with the DCM-2. Proceed as follows:

1. If prompted to install a modem, answer "no". Proceed to enter a name (e.g., "DCM-2") and select an icon (any will suffice) in the "Connection Description" box. Click the "OK" button.
2. The "Connect to" box should open next. At the bottom of the box, set the "Connect using" selection to the computer COM port that has been connected to the DCM-2. Click the "OK" button.
3. The COM port properties box should open next; this is where the communication settings are established. The correct settings are:
 - a. Bits per second = "1200"
 - b. Data bits = "8"
 - c. Parity = "none"
 - d. Stop bits = "1"
 - e. Flow control = "none"
4. With the appropriate settings entered from Step 3, above, click "OK". Communications should now be enabled.
5. Press the "Enter" key twice. "OK" should be displayed indicating that HyperTerminal® is communicating with the DCM-2.

APPENDIX Serial Commands

COMMANDS AND ARGUMENTS

Commands can be used for a variety of functions including changing the operating configuration of the actuator, verifying operation settings, calibration and accessing diagnostic information. There are essentially four different types of commands:

1. Dual-purpose commands. These commands can be used to either modify actuator configuration settings or display existing actuator settings. In order to set or make a change to the settings, the command requires an argument (*n*). If the command is used for display purposes only, the argument is omitted. Examples of these commands include "temperature" and "demlos".
2. Display only commands. These commands are used to display diagnostic or operating information such as present signal values. No arguments are required. Examples include the "stat" command and the "signals" command.
3. Set only commands. These commands serve only to make a parameter change. Typically, they apply to the actuator calibration. This type of command requires an argument, but unlike dual-purpose commands, they return an error message when entered without an argument. Examples include the "charset" and "trimfdbk4mA" command.
4. Execute action commands. These commands serve to reset, enable or disable features. Entering these commands produces an immediate action. Examples include the "reset" and "restoremodes" command.

The available commands are listed on the next several pages and each is described in detail. The command description explains the use or uses of the command, while the argument column describes any applicable arguments. Arguments are denoted as *n*. Note that the commands described as "sets and/or displays" signify dual-purpose commands that can be used with or without an argument for setting or verifying configuration settings.

Beck Serial Cable Pinout Table

RJ-11 6-PIN PLUG PIN NO.	DB-9 9-PIN PLUG PIN NO.
1	8
2	2
3	9
4	5
5	3
6	7

Beck Serial Cable Illustration
(Part Number 20-0511-13)

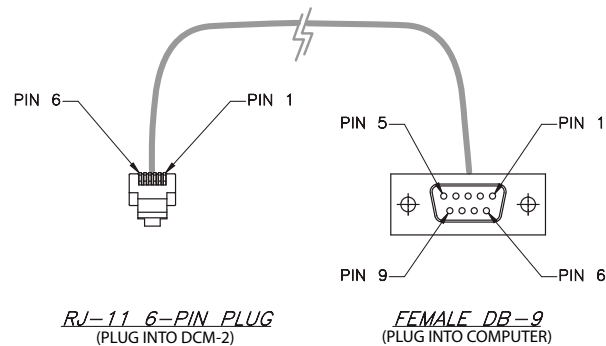

APPENDIX Serial Commands

SERIAL COMMANDS

The following is a categorized list of Serial commands available through the RS-232 interface. These commands are described in detail on the pages that follow.

Output Shaft Position Sensing Commands

cpsvat0pct	travel
------------	--------

General Configuration Commands

alarmout	opmode
alarmoutmask	restoremodes
configformodel	sernum
drvdir	stallprot
drvtiming	stalltime
limitalarm	stepsize
gearratio	

Torque Sensing Commands

ovtstop	torq100pct
ovtstoplevel	torqalarm
torq	torqconst
torq0k	torqenable
torq0pct	torqprof

HART® Configuration Commands

harttype	polladdr
----------	----------

Diagnostic and Information Commands

demsource	signals
help	stat
ledtest	temperature
reset	uninstall

Demand Signal Commands

dem0pctma	demlostgtp delay
dem100pctma	trimdem4ma
demlos	trimdem20ma
demlostgtp	

Demand Characterizer Commands

charclear	charset
charlist	demfunc

Feedback Signal Commands

fdbk0pctma	trimfdbk4ma
fdbk100pctma	trimfdbk20ma
fdbkfunc	iomode

Output Shaft Position Sensing Commands

Command	Description	Argument <i>n</i> and Information
cpsvat0pct <i>n</i>	Sets/displays the DCM-2 voltage setting used to determine 0% signal from the CPS-4. Voltage is dependent upon the actuator model. Typically, this setting does not need to be changed.	<i>n</i> = desired voltage as a decimal (carried out to 3 decimal places). The standard signal setting is approx. 1.3 V.
travel <i>n</i>	Sets/displays the number of degrees that represents 100% travel. This command does not shift the 0% position; when increasing travel from a reduced travel setting, the 0% position may need to be changed first to keep travel within acceptable end points. The end points are defined by the CPS-4 voltage range.	<i>n</i> = desired length of travel in degrees. This value cannot exceed the maximum output shaft rotation of the actuator.

General Configuration Commands

Command	Description	Argument <i>n</i> and Information
alarmout <i>n</i>	Sets/displays the polarity of the alarm output solid state relay.	<i>n</i> = "0": open on Alarm <i>n</i> = "1": closed on Alarm Upon loss of power, the relay is open regardless of the setting.

Command	Description	Argument <i>n</i> and Information
alarmoutmask <i>n</i>	Sets/displays (in hexadecimal format) which conditions will cause an alarm: 0x00000001 - Demand Loss of Signal 0x00000002 - Torque High 0x00000004 - Stall Condition 0x00000008 - Torque Stop 0x00000010 - Stop/Limit 0x00000020 - Feedback Loss of Signal 0x00000040 - Temperature too High/Low 0x00000080 - Position Outside of Limits 0x00000100 - Real-time Clock Failure 0x00000200 - Torque Measurement Failure 0x00000400 - Position Analog/Digital Circuit Failure 0x00000800 - Demand Measurement Failure 0x00002000 - Position Loss of Signal 0x00004000 - Temperature Measurement Failure 0x00008000 - Memory Failure 0x00010000 - Invalid Button Pressed 0x00020000 - Demand too High	<i>n</i> = "0x0": no listed condition causes a status alarm <i>n</i> = "0xffffffff": all listed conditions cause a status alarm <i>n</i> = hexadecimal value for specific condition(s) which will cause an alarm. Multiple conditions may be selected by performing a hexadecimal addition of the condition values; e.g., Stall Condition and Torque Stop alarms -- hex 0x04 + 0x08 = 0x0C.
configformodel <i>n</i>	Sets certain DCM-2 default values based on the actuator Serial number. These values are direction rotation for an increasing CPS-4 signal, expected range of CPS-4 signal and the maximum travel.	<i>n</i> = "1": executes command
drvdir <i>n</i>	Sets/displays the actuator output shaft rotation direction resulting from an increasing Demand signal.	<i>n</i> = "0": CW rotation <i>n</i> = "1": CCW rotation
drvtiming <i>n</i>	Sets/displays number of seconds the actuator takes to travel from 0% to 100%. Also indicates frequency of motor voltage as provided by the DCM-2.	<i>n</i> = seconds
gearratio <i>n</i>	Sets/displays the gear ratio from the motor to the output shaft.	See page 7 for <i>n</i> value (gear ratio) appropriate for the actuator model and stroke timing.
limitalarm <i>n</i>	Sets/displays alarm action if the actuator travels outside of the electronic limits and contacts an over-travel limit switch.	<i>n</i> = "0": mute (no alarm) <i>n</i> = "1": always
opmode <i>n</i>	Sets/displays the mode that controls the Demand signal source. This mode selects analog or digital control.	<i>n</i> = "0": analog Demand <i>n</i> = "1": digital Demand <i>n</i> = "2": run CW <i>n</i> = "3": run CCW <i>n</i> = "4": stay <i>n</i> = "5": stop
restoremodes <i>n</i>	Returns the DCM-2 settings to the original factory configuration.	<i>n</i> = "1": executes command
sernum <i>n</i>	Sets the actuator serial number.	<i>n</i> = serial number
stallprot <i>n</i>	Sets/displays stall protection state.	<i>n</i> = "0": disabled <i>n</i> = "1": enabled
stalltime <i>n</i>	Sets/displays time the actuator runs in one direction before stall alarm is activated.	<i>n</i> = seconds: acceptable range is 30–300 seconds.
stepsize <i>n</i>	Sets/displays the size of one incremental movement of the output shaft.	<i>n</i> = % of travel desired: acceptable range is 0.10%–2.5%. Include "%" symbol after number, otherwise the unit of measure will be degrees.

APPENDIX Serial Commands

Torque Sensing Commands

Command	Description	Argument <i>n</i> and Information
ovtstop <i>n</i>	Sets/displays whether motor power will be removed during severe overtorque conditions. Torque sensing must be enabled.	<i>n</i> = "0": disabled <i>n</i> = "1": enabled
ovtstoplevel <i>n</i>	Sets/displays the torque magnitude associated with severe output shaft torque conditions.	<i>n</i> = allowable torque magnitude (without stopping motor) in percentage of actuator rating. May be set from 25% to 115% (factory set to 115%).
torq	Displays the measurement of the torque on the output shaft as a percentage of actuator rating. Also displays related values such as torq0k and torqconst.	No argument.
torq0k <i>n</i>	Sets/displays the value of DCM-2 internal measurement corresponding to 0% torque on the output shaft.	<i>n</i> = the zero torque value in counts (noted on label inside DCM-2 cover).
torq0pct <i>n</i>	An alternate method for setting torq0k. Useful when the correct torq0k value is not known. To use this command, remove all load from the output shaft, then execute torq0pct with argument "0" to let the DCM-2 know that the torque sensing should be reading 0%.	<i>n</i> = "0"
torq100pct <i>n</i>	An alternate method for setting torqconst. Useful when the correct torqconst value is not known, but the exact output torque is known. To use this command, load the output shaft with an exact load, preferably 100%. Execute torq100pct to let the DCM-2 know what the torque sensing should be reading.	<i>n</i> = exact output shaft torque as a percent of rated load of the actuator.
torqalarm <i>n</i>	Sets and/or displays the torque magnitude associated with the first level of alarm.	<i>n</i> = allowable torque magnitude without alarm, in percentage of actuator rating. May be set from 20% to 105%.
torqconst <i>n</i>	Sets/displays the value of DCM-2 internal measurement corresponding to the torque span (the measurement at 100% minus the measurement at 0%).	<i>n</i> = the torque span value in counts (noted on label inside DCM-2 cover).
torqenable <i>n</i>	Sets/displays the status of torque sensing (enabled or disabled).	<i>n</i> = "0": disabled <i>n</i> = "1": enabled
torqprof	Displays a three table column: 1. Maximum travel divided into 10 segments 2. Peak torque measured in each segment with motor running CW 3. Peak torque measured in each segment with motor running CCW	No argument.

HART® Configuration Commands

Command	Description	Argument <i>n</i> and Information
harttype <i>n</i>	Sets/displays the DCM-2 HART DD (Device Description). "239" is the proper DD; other DDs are for temporary use if the new DD is not available.	<i>n</i> = "1": ESR-D <i>n</i> = "10": Beck DCM <i>n</i> = "239": Beck MK2
polladdr <i>n</i>	Sets/displays the polling address used by the HART master to find individual devices if the HART bus has more than one device.	<i>n</i> = polling address number between "0" and "15"). Unless multiple HART devices are connected in parallel on a single bus, polling address should be "0".

Diagnostic and Information Commands

Command	Description	Argument <i>n</i> and Information
demsources	Provides a readout of information regarding the Demand on the actuator including the source of the Demand signal (Handswitch, demlos or Analog I/P), mode (follow, hold, CW, CCW, Stay or Stop), currently applied Demand signal as a %, the Demand function (linear, square root, square, or special), and the Demand out as a % (dem out shows the signal adjusted when using a non-linear Demand function (demfunc command)).	No Argument
help <i>n</i>	Displays help text for a specific command or lists all available Serial commands.	<i>n</i> = command name <i>n</i> = "all"
ledtest <i>n</i>	Tests the functionality of the DCM-2 LEDs individually or as a group. If "all" is selected, the command will consecutively cycle through each LED twice. If an individual LED is selected, it will flash 12 times.	<i>n</i> = "1": DEMAND <i>n</i> = "2": POSITION <i>n</i> = "3": TRQ/THRUST <i>n</i> = "4": STALL <i>n</i> = "5": TEMP °F <i>n</i> = "6": FB OPEN <i>n</i> = "7": UVOLT <i>n</i> = "8": ACKNOWLEDGE <i>n</i> = "100": FWD <i>n</i> = "101": REV <i>n</i> = "102": STAT <i>n</i> = "All"
reset <i>n</i>	Performs the same reset sequence as when power is removed and reapplied.	<i>n</i> = "1": must equal "1" for command to execute.
signals	Displays the present DCM-2 readings of four signals: Position signal from CPS-4 Demand Feedback Torque	No argument = signal readings are displayed. <i>n</i> = "all": an extended set of data is displayed.
stat	Displays information on the status of the actuator, including: Time / Date, Demand, Position, Error (Demand minus Position), Step size, Dead band, Motor Status, Motor Run Time, Line Frequency, Motor Starts, Motor Reversals/Stalls, Number of Overtorque conditions, Positive & Negative Peak Torque (%), CW and CCW Inhibitor Status, Alarms	No argument
temperature <i>n</i>	Displays three values describing the ambient temperature in the actuator. Low extreme, present, high extreme. Can also change the temperature units.	No argument = temperatures are displayed. <i>n</i> = "F": changes units to Fahrenheit <i>n</i> = "C": changes units to Celsius
unstall	Resets the Stall Protection alarm to restore power to the motor. If the motor remains physically stalled, the Stall Protection alarm will recur.	No argument.

APPENDIX Serial Commands

Demand Signal Commands

Command	Description	Argument <i>n</i> and Information
dem0pctma <i>n</i>	Sets/displays the Demand signal value that corresponds to 0% actuator position.	<i>n</i> = Demand signal as a decimal in mA. Minimum value is 0.50; maximum value is 100% Demand less 4.00 mA (e.g., if 100% Demand is 20.00 mA, the 0% value must be set for 16.00 mA or less).
dem100pctma <i>n</i>	Sets/displays the Demand signal value that corresponds to 100% actuator position.	<i>n</i> = Demand signal as a decimal in mA. Minimum value is 0% Demand plus 4.00 mA (e.g., if 0% Demand is 4.00 mA, the 100% value must be set for 8.00 mA or greater). Maximum value is 21.00 mA.
demlos <i>n</i>	Sets/displays the Demand signal threshold, below which the DCM-2 recognizes the signal has been lost. The threshold is entered as a value in mA. This command also sets/displays the action initiated by the actuator during LOS (Loss Of Signal). LOS action options are "sip" (stay in place) or "gtp" (go to position). Demlos always reports both settings, but only sets one argument at a time. Demlos must be used twice to set both the threshold and action.	<i>n</i> = Demand signal in mA below which LOS occurs (e.g., the typical value for a 4–20 mA system is 3.20). -OR- <i>n</i> = "sip", "gtp" or "pat". The "pat" argument acts the same as "sip", but also suppresses the alarm-- this is used in some pulsed applications.
demlogtp <i>n</i>	Sets/displays the position to which the actuator will run upon loss of the Demand signal (LOS). This command has no effect if the actuator is set to "sip" (stay in place).	<i>n</i> = desired position of actuator expressed as a percentage of actuator travel in decimal form (e.g., 50% = 50.00).
demlogtp delay <i>n</i>	Sets the time delay in seconds before the actuator will move to the position set in "demlogtp". Entering this command without an argument will return the present gtp and delay settings.	<i>n</i> = time delay in seconds. Acceptable values are 0 (default) to 25.5.
trimdem4ma 4	Trims the Demand analog-to-digital sensing circuit to be accurate at 4 mA. This command should only be used when the Demand signal at the actuator is exactly 4.0 mA. Trim is factory set and should not normally require recalibration.	"4" is the only acceptable value; this trim can only be performed at 4 mA.
trimdem20ma 20	Trims the Demand analog-to-digital sensing circuit to be accurate at 20 mA. This command should only be used when the Demand signal at the actuator is exactly 20.0 mA. Trim is factory set and should not normally require recalibration.	"20" is the only acceptable value; this trim can only be performed at 20 mA.

Demand Characterizer Commands

Command	Description	Argument <i>n</i> and Information
charclear <i>n</i>	Clears a preconfigured Demand characterizer curve node by setting it to "unused". Any node numerically higher will be set to "unused" also.	<i>n</i> = node number: between 1 and 21.
charlist <i>n</i>	Displays the X-values and Y-values of Demand characterizer curve node(s).	<i>n</i> = node number: between 1 and 21. <i>n</i> = "all": displays all nodes
charset <i>n1, n2, n3</i>	Sets the X-values and Y-values of a specific node of the characterizer curve. The three arguments must be separated by commas.	<i>n1, n2, n3</i> = (<i>n1</i> is node number to modify, <i>n2</i> is X-value as a percentage, <i>n3</i> is Y-value as a percentage)
demfunc <i>n</i>	Sets/displays the Demand signal characterization function.	<i>n</i> = "0": linear <i>n</i> = "1": square root <i>n</i> = "4": special curve <i>n</i> = "5": square

Feedback Signal Commands

Command	Description	Argument <i>n</i> and Information
fdbk0pctma <i>n</i>	Sets/displays the mA value of the Feedback signal that represents the 0% output shaft position. May also be set for decreasing direction of Feedback. See page 34.	<i>n</i> = desired Feedback signal in mA at 0% output shaft position. Minimum value is 3.00 mA and the maximum must be at least 4.00 mA less than the Feedback signal value for the 100% output shaft position.
fdbk100pctma <i>n</i>	Sets/displays the mA value of the Feedback signal that represents the 100% output shaft position. May also be set for decreasing direction of Feedback. See page 34.	<i>n</i> = desired Feedback signal in mA at 100% output shaft position. Minimum value must be at least 4.00 mA greater than the Feedback signal value for the 0% output shaft position. Maximum value is 21.00 mA.
fdbkfunc <i>n</i>	Sets/displays the curve used to calculate the Feedback signal.	<i>n</i> = "0": linear <i>n</i> = "1": inverse Demand (curve enabled)
trimfdbk4mA <i>n</i>	Trims the Feedback signal at 4 mA. Calibrated at the factory, should not normally require calibration.	<i>n</i> = present Feedback signal from the DCM-2 in mA.
trimfdbk20mA <i>n</i>	Trims the Feedback signal at 20 mA. Calibrated at the factory, should not normally require calibration.	<i>n</i> = present Feedback signal from the DCM-2 in mA.
iomode <i>n</i>	Sets/displays the function of a DCM-2 connector pin. May be enabled for Feedback or potentiometer.	<i>n</i> = "0": none <i>n</i> = "1": Feedback enabled <i>n</i> = "2": potentiometer power enabled.

INDEX

Appendices	50–69	Maintenance	38–45
HART® Communication	50–57	Component Replacement	38
HART® Messages	58–61	Control End / CPS-4	44–45
Serial Communication	62	DCM-2	41–43
Serial Commands	63–69	Fuses	40
Applications Reviews	71	Gaskets	38
Auxiliary Limit Switches	25	Lubrication	38
Setting Switches	25	Motor	38
Configuration/Calibration	24–37	Recommended Replacement Kits	38–39
Contactless Position Sensor (CPS-4)	23, 44	Routine	38
Demand Characterization Curves	30–31	Mounting	12
Digital Control Module (DCM-2)	20–23	Outline Dimension Drawings	8–9
Component Locations	21	Position Feedback Signal	34–35
Interfaces	20	Power Quality	15
Overview LEDs	22	Precautionary Information	10
Pushbutton Controls	23	Product Demonstrations	71
Status Indication LEDs	22	Restore Factory Settings	37
Direction of Output Shaft Rotation	26–27	Safety Precautions	10
Electronics	20–23	Self-Locking Mechanism (SLM)	4
General Operation Information	11	Serial Commands	63–69
General Specifications	6–7	Serial Communication	62
Handswitch	4, 11	Services	71
Handwheel	4, 11	Site Surveys	71
HART® Communication	50–57	Spare Parts, Recommended	38
HART® Device Description Menu	52	Specification Writing	71
HART® Messages	58–61	Stall Protection	33
How to Obtain Service	71	Start-up	19
Installation	12–18	Step Size	33
Electrical	15	Storage Information	10
Linkage	12–14	Table of Contents	3
Link-Assist™	13	Temperature Sensing	37
Mechanical	12–14	Torque Sensing	36–37
Wiring	16–18	Live/Historical Torque	36
Introduction	2	Overtorque Protection	36–37
Limit Switches (Over-travel)	24	Travel (Degrees Rotation)	28–29
Setting Switches	24	Change Travel	29
Linkage Kits	13	Troubleshooting	46–49
Loss of Demand Signal (LOS)	32	Warranty Statement	71

SERVICES

PRODUCT DEMONSTRATIONS

Each of Beck's Sales Engineers has access to a complete set of actuator models so that he can demonstrate virtually any of their features at your location. In order to arrange to see a Beck actuator in your plant or office, contact Beck's Sales Department.

SITE SURVEYS

Beck Sales Engineers are available to discuss your process control requirements. Often a visit to your location is the best way to gain a thorough understanding of your needs, in order to meet them most accurately and completely.

Mounting hardware, torque requirements, linkage, control signal information, and optional equipment can be analyzed most effectively at the work site. Beck's analysis at the job site can help ensure that specifications are accurate, especially in the case of complex applications.

APPLICATION REVIEWS

By sharing your needs with a Beck Sales Engineer you can take advantage of the best application advice for the type of control you need.

This review will yield a better understanding of the versatility of Beck actuators for your installations, as well as complete details on options and accessories to make the process as effective as possible.

SPECIFICATION WRITING

Beck provides specification writing assistance in order to help you specify and order the right actuators for your applications. Beck Sales Engineers will work with you to make it easier for you to obtain the proper equipment and give you confidence that no details are overlooked.

HOW TO OBTAIN SERVICE

Factory repair of actuators or subassemblies is available for both normal and emergency service. To assure prompt processing, contact the factory to receive a Returned Material Authorization (RMA) number. If a repair estimation is desired, please send the name and phone number of your contact for service authorization. It is helpful to include a description of the work desired with the shipment or, in the event of a problem, the malfunction being experienced.

THREE YEAR LIMITED EQUIPMENT WARRANTY

Beck warrants to Buyer that: (i) for a period of 3 years from the date of shipment, the Equipment manufactured by Beck shall materially conform to Beck's published standard specifications in effect as of the date of shipment; and (ii) the Beck Equipment will be free from defects in materials and workmanship. This warranty does not apply to normal wear and tear, or where Beck Equipment failure is a result of improper installation, improper storage, misuse or improper maintenance, or water ingress related to Buyer or its agents failing to apply the stated torque requirements to fasteners when attaching covers or failing to replace temporary conduit plugs as stated in the installation instructions, or entry through conduits.

During the Limited Warranty Period, Buyer shall notify Beck of any alleged warranty claim within 30 days from the date Buyer discovers, or upon reasonable inspection should have discovered, such alleged claim (but in any event prior to the end of the Limited Warranty Period), and Buyer shall return the Beck Equipment in question, at Buyer's expense, to Beck for evaluation, in compliance with the terms stated in the "Return of Equipment" article in the Sales Contract. If Beck determines that the Beck Equipment fails to conform to the limited warranty, then, at Beck's sole discretion and its expense (subject to Buyer's conformity with the warranty), Beck will either: (i) repair or replace the Beck Equipment, without charge, at Beck's factory, or (ii) refund the purchase price of such Beck Equipment, less any applicable discounts, rebates, or credits. In no event will Beck's liability exceed the contract price actually paid for such Beck Equipment subject to a warranty claim. Beck makes no warranty, express or implied, with respect to any Buyout Item. This limited warranty is not transferable or assignable to any transferees of the Beck Equipment.

THIS WARRANTY IS EXPRESSLY IN LIEU OF ANY OTHER EXPRESS OR IMPLIED WARRANTY, INCLUDING IMPLIED WARRANTIES OF MERCHANTABILITY AND FITNESS FOR A PARTICULAR PURPOSE, AND ALL OTHER OBLIGATIONS OR LIABILITIES OF BECK. BUYER ACKNOWLEDGES THAT: (i) BECK HAS MADE NO INDEPENDENT INVESTIGATION OF THE SUITABILITY OF THE EQUIPMENT FOR BUYER'S INTENDED USE OR EXISTING SYSTEMS; AND (ii) BUYER HAS NOT RELIED UPON ANY REPRESENTATION OR WARRANTY MADE BY BECK OR ANY OTHER PERSON ON BECK'S BEHALF, EXCEPT AS SPECIFICALLY PROVIDED IN THE SALES CONTRACT. THIS SECTION SETS FORTH BUYER'S SOLE AND EXCLUSIVE REMEDY FOR ANY BREACH OF THE LIMITED WARRANTY SET FORTH IN THIS SECTION.

A 100% EMPLOYEE OWNED COMPANY

BECK

~ founded 1936 ~

SINCE 2021



HAROLD BECK & SONS, INC.

11 TERRY DRIVE • NEWTOWN, PENNSYLVANIA 18940 • USA

PHONE: 215-968-4600 • FAX: 215-860-6383 • E-MAIL: sales@haroldbeck.com

www.haroldbeck.com

Made in USA

