

**BECK**<sup>®</sup>

# INSTRUCTION MANUAL

---

---



# ***INTRODUCTION***

---

This manual contains the information needed for the operation and maintenance of the Beck 11-489 multi-turn actuator equipped with the Digital Control Module (DCM-3), manufactured by Harold Beck & Sons, Inc. of Newtown, Pennsylvania.

The 11-489 is a rugged, multi-turn addition to the G11 family of actuators and shares the same time-proven reliability, features, and performance advantages. For applications requiring up to 120 lb-ft (163 N•m) of actuator torque, the 11-489 is available with multiple travel span options, ranging from 5 turns to 408 turns.

# ***TABLE OF CONTENTS***

---

<b>Introduction</b> .....	<b>2</b>
<b>General Specifications</b> .....	<b>4</b>
<b>Outline Dimension Drawings</b> .....	<b>6</b>
<b>Precautionary Information</b> .....	<b>8</b>
<b>General Operation Information</b> .....	<b>9</b>
<b>Installation</b> .....	<b>9</b>
<b>Mechanical</b> .....	<b>9</b>
<b>Electrical</b> .....	<b>10</b>
<b>Wiring</b> .....	<b>11</b>
<b>Start-up Checklist</b> .....	<b>12</b>
<b>Electronics</b> .....	<b>13</b>
<b>Configuration/Calibration</b> .....	<b>17</b>
<b>Maintenance</b> .....	<b>29</b>
<b>Troubleshooting</b> .....	<b>38</b>
<b>Appendices</b> .....	<b>43</b>
<b>HART® Menu</b> .....	<b>43</b>
<b>HART® Communication</b> .....	<b>44</b>
<b>HART® Messages</b> .....	<b>49</b>
<b>Serial Communication</b> .....	<b>52</b>
<b>Serial Commands</b> .....	<b>53</b>
<b>Optional DCM-3 w/ Feedback Display</b> .....	<b>60</b>
<b>Index</b> .....	<b>62</b>
<b>Services</b> .....	<b>63</b>

# GENERAL SPECIFICATIONS

Actuator Power	120 Vac, single-phase, 60 Hz (Standard), 50 Hz (Optional) 208, 240 & 480 Vac, 50 or 60 Hz (Optional)	Allowable Tolerance	+10%	-15%	
<b>Maximum Current (Amps) by Supply Voltage</b>					
		<b>Voltage (Vac)</b>			
<b>Model</b>	<b>Maximum Power (VA)</b>	<b>120</b>	<b>208</b>	<b>240</b>	<b>480</b>
11-489	400	3.1	1.8	1.6	.78
Operating Conditions	-40° to 85°C (-40° to 185°F) 0 to 100% relative humidity, non-condensing				
Standard Communication Interface	HART protocol (Rev. 5 -- burst mode is not supported) Pushbutton / LEDs DB9 Serial port				
Demand Input Signal Options	4–20 mA (1–5 Vdc input is possible with the removal of the “R11” resistor located on the DCM-3 board—see page 34)				
Minimum Step Size	0.1% (0.15% typical, configurable from 0.1 to 2.5% of full span)				
Linearity	1.1% of span, max. independent error				
Hysteresis	0.20% of span at any point				
Demand input Signal Characterization	<p><b>Linear:</b> Actuator output shaft moves proportionally to the input signal</p> <p><b>Square:</b> Actuator output shaft moves proportionally to the square of the input signal</p> <p><b>Square Root:</b> Actuator output shaft moves proportionally to the square root of the input signal</p> <p><b>Custom:</b> Actuator output shaft moves according to the configurable 20-segment (maximum) response curve</p>				
Position Feedback Signal	4–20 mA				
Isolation	Demand input and position Feedback signals are isolated from ground and the AC power line. Signal buffering provides 24 Vdc isolation between the Demand and Feedback signals				
Action on Loss of Power	Stays in place				
Action on Loss of Input Signal	Stays in place or drives to any preset position (configurable)				
Stall Protection	If the motor tries to run in one direction for more than the configured stall time (configurable from 30 to 3600 seconds), the DCM-3 will shut off power to the motor (feature can be enabled/disabled)—factory default is enabled.				

Alarm Annunciation	Available at terminal E. Depending on actuator power, the voltage is either 120 Vac (80 mA max.) or 240 Vac (40 mA max.).																		
Temperature Indication	Measures the internal temperature of the actuator and triggers an alarm when the temperature exceeds the rating.																		
Over-travel Limit Switches	Two SPDT switches (CW and CCW) provide over-travel protection.																		
Auxiliary Switches	Four 6 A, 120 Vac switches. Switches are labeled S1 to S4 and are cam-operated, field-adjustable. Unless otherwise specified, auxiliary switches are factory set: S1 and S4 are set to operate just before reaching the CCW travel limit. S2 and S3 are set to operate just before reaching the CW travel limit. (see page 18 for a switch setting diagram)																		
Handswitch	Permits local electrical operation, independent of controller signal. Standard on all units. An auxiliary contact is available as an option for remote auto indication (rated 2.5 A at 120 Vac).																		
Handwheel	Provides manual operation without electrical power.																		
Motor Assembly	120 Vac, single-phase, no-burnout, non-coasting motor. Requires no contacts or moving parts.																		
Gear Train	High-efficiency, precision-cut, heat-treated alloy steel and ductile iron spur gears. Interchangeable gear modules permit field change of torque/ timing.																		
Enclosure	Precision-machined, aluminum alloy castings painted with corrosion-resistant polyurethane paint provide a rugged, dust-tight, weatherproof enclosure. Actuators designed for hazardous classified locations are also available. Type 4X; IP68, 3 meters/48 hours*. *NOTE: Internal water damage is not covered by warranty.																		
Output Shaft Rotation	Dependent on the control end (see below). <table border="1" data-bbox="597 1409 1427 1776"> <thead> <tr> <th>Control End Assembly (part no.)</th> <th>Travel Range (turns)</th> </tr> </thead> <tbody> <tr> <td>23-2348-10</td> <td>5–9</td> </tr> <tr> <td>23-2348-11</td> <td>7–14</td> </tr> <tr> <td>23-2348-12</td> <td>14–25</td> </tr> <tr> <td>23-2348-13</td> <td>25–45</td> </tr> <tr> <td>23-2348-14</td> <td>35–70</td> </tr> <tr> <td>23-2348-15</td> <td>65–126</td> </tr> <tr> <td>23-2348-16</td> <td>115–227</td> </tr> <tr> <td>23-2348-17</td> <td>200–408</td> </tr> </tbody> </table>	Control End Assembly (part no.)	Travel Range (turns)	23-2348-10	5–9	23-2348-11	7–14	23-2348-12	14–25	23-2348-13	25–45	23-2348-14	35–70	23-2348-15	65–126	23-2348-16	115–227	23-2348-17	200–408
Control End Assembly (part no.)	Travel Range (turns)																		
23-2348-10	5–9																		
23-2348-11	7–14																		
23-2348-12	14–25																		
23-2348-13	25–45																		
23-2348-14	35–70																		
23-2348-15	65–126																		
23-2348-16	115–227																		
23-2348-17	200–408																		
Mounting Orientation	Any orientation—no limitations.																		
Standards	CSA Labeled (US & Canada); CE Compliant; UKCA Compliant																		

# OUTLINE DIMENSION DRAWINGS

**SOLID SHAFT  
OPTION**

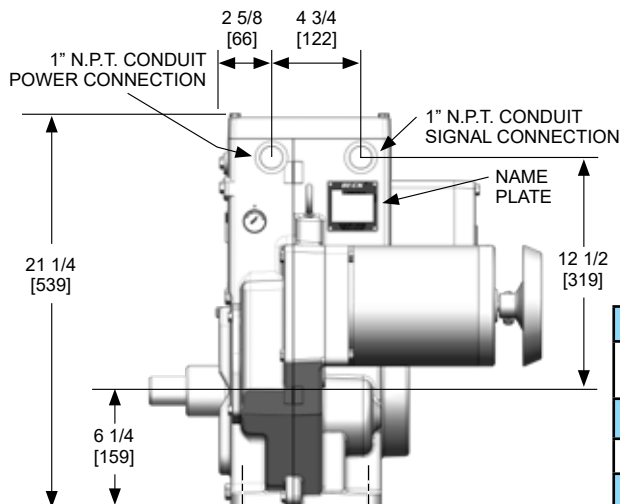
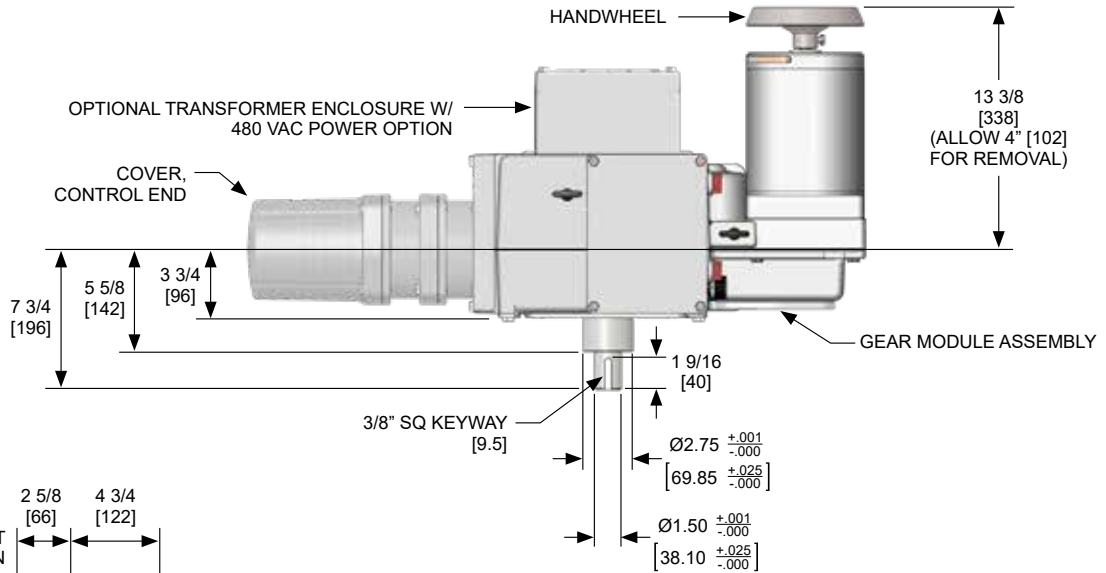
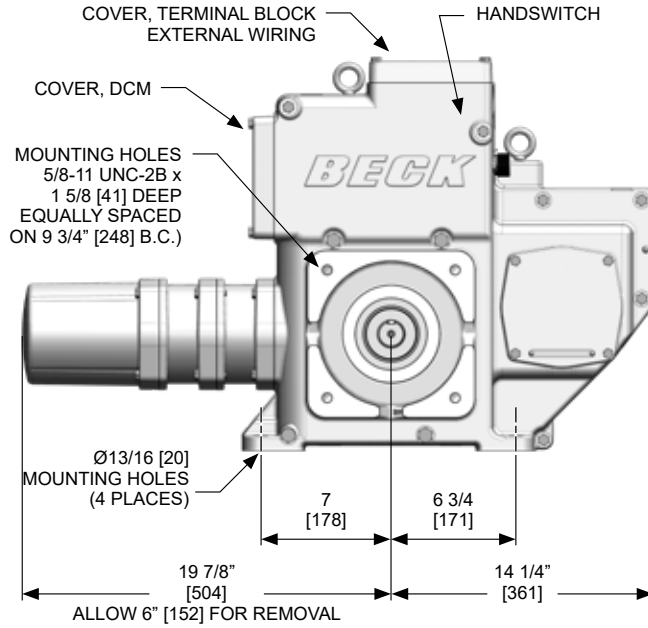

Approximate Weight 260 lbs. (118 kg)

### Recommended Screw Torques

	Screw Size (in.)	Wrench Size (in.)	Torque	
			lb-ft	N·m
Coupling Screw	-	-	*	*
Mounting Bracket Screw	5/8-11	15-16	100	135
Body Screw	1/2-13	3/4	50	68
Body Screw	3/8-16	9/16	20	27
Cover Screw	5/16-18	1/2	10	14
Motor Screw	3/8-16	9/16	16	22
Gear Module Screw	5/16-18	1/2	10	14

\*Varies per application - refer to the valve mounting specification sheet shipped with your actuator.

Dimensions are in inches and [mm] unless otherwise specified.

**HOLLOW SHAFT  
OPTION**

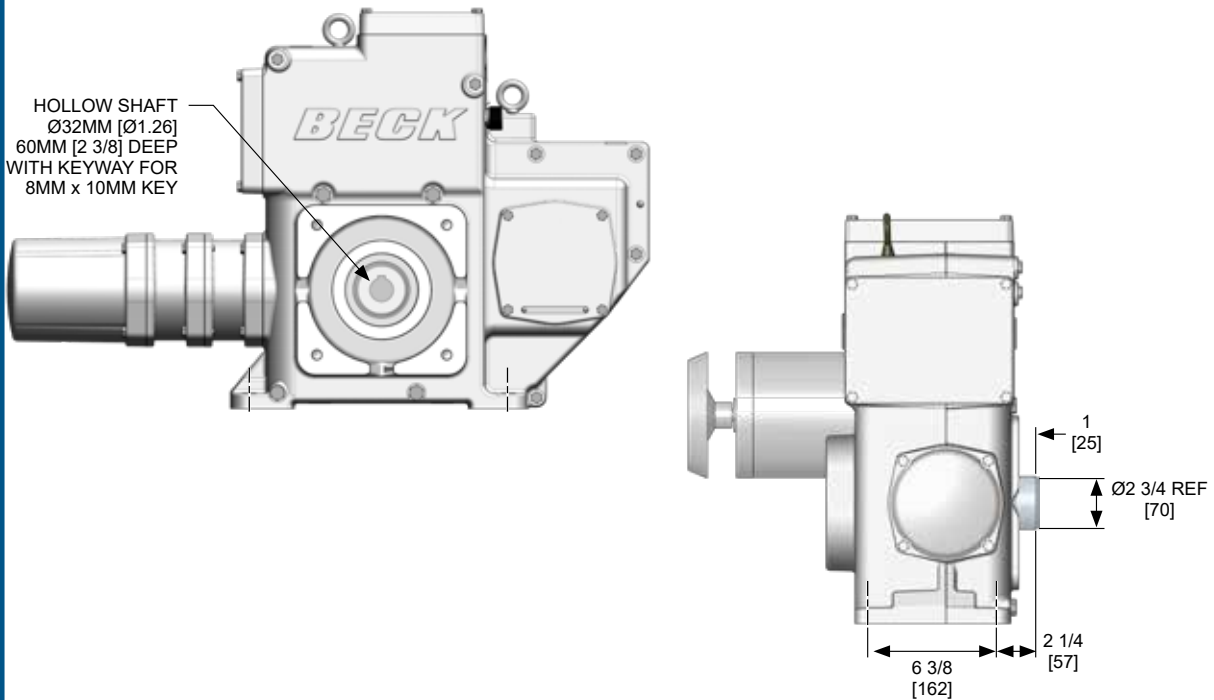

**HOLLOW SHAFT  
OPTION w/ FA14 MOUNTING PLATE**

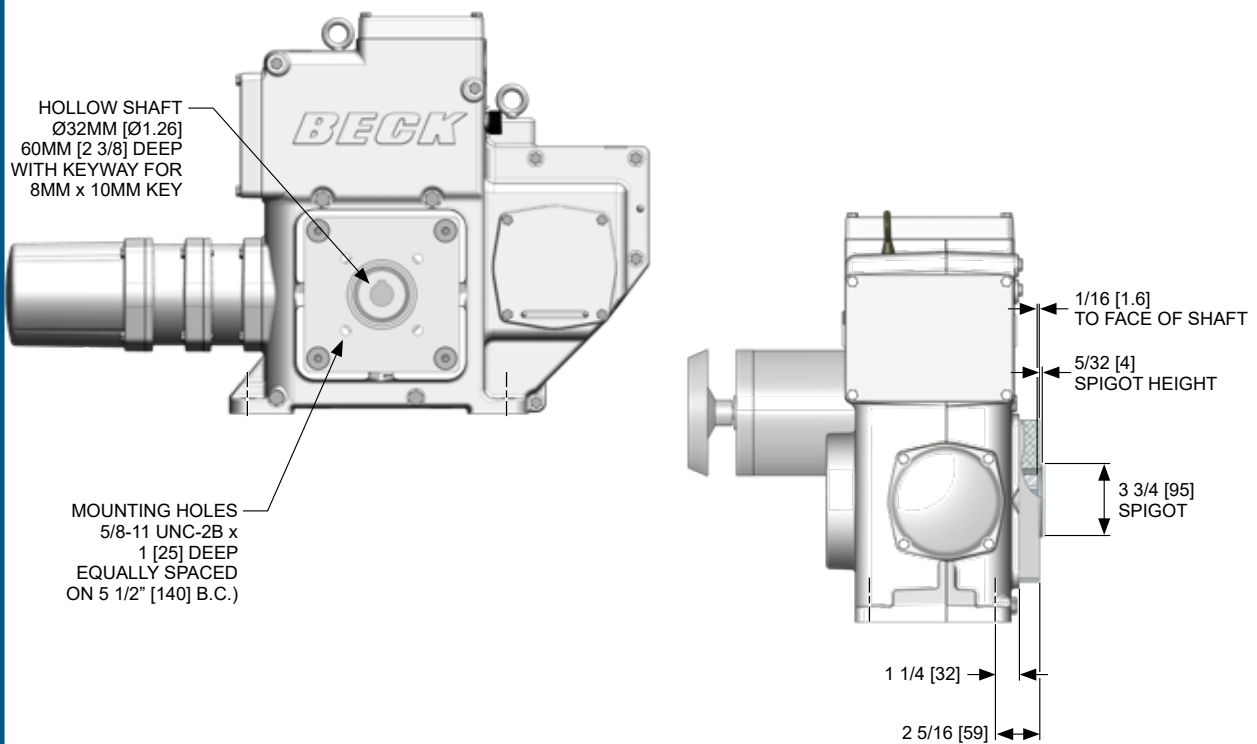

# PRECAUTIONARY INFORMATION

## SAFETY PRECAUTIONS



### WARNING

Installation and service instructions are for use by qualified personnel only. To avoid injury and electric shock, do not perform any servicing other than that contained in this manual. Please read and understand the appropriate sections in this manual before attempting to install or operate your drive.

## STORAGE INFORMATION

Beck actuators should be stored in a clean, dry area where the temperature is between -40° and 85°C (-40° to 185°F).

Damage due to moisture while in storage is not covered by warranty.

## INSTALLATION—MECHANICAL

There are many considerations regarding proper mechanical installation—see the instructions beginning on page 9 for details. Refer to the outline dimension drawings for physical dimensions and required clearances. Follow manufacturer precautions.

## INSTALLATION—ELECTRICAL

See the instructions beginning on page 10 for details regarding electrical installation.



### CAUTION

For maximum safety, the Beck actuator body should be grounded. Use the green grounding screw in the wiring compartment of the actuator.



### CAUTION

Always close covers immediately after installation or service to prevent moisture or other foreign matter from entering the actuator.

## CONDUIT ENTRIES

Conduits are provided for power and signal wiring. Temporary plugs are installed in the conduit entrances at the factory for shipping only and are not intended for permanent use. Prior to actuator operation, all conduit entrances must be properly sealed in accordance with National Standards or Regulatory Authorities.

# GENERAL OPERATION INFORMATION

## MODES OF OPERATION

There are three basic modes of operation:

- **Handwheel**—local mechanical control
- **Handswitch**—local electrical control
- **Automatic**—remote electrical control signal

Any or all of these modes can be used to test basic operation of your actuator during start-up.

## HANDWHEEL

The Handwheel permits manual operation of the actuator without power. The Handwheel is coupled directly to the motor shaft at the rear of the motor housing and it rotates when the motor runs.

If power is available, the Handswitch must be moved to the STOP position before manually operating the Handwheel.

## HANDSWITCH

A Handswitch allows local electric control at the actuator. In either of the STOP positions, the motor is blocked from running. In the CW or CCW positions, the motor runs to move the output shaft in the corresponding direction. When moving the output shaft using the Handswitch, the motor will stop when the over-travel limit switches are reached.

The Demand signal can position the actuator only when the Handswitch is in the AUTO position.

## AUTOMATIC MODE

When the Handswitch is placed in the AUTO position, the actuator is in automatic mode and

responds to a Demand signal (also called the setpoint). The Digital Control Module (DCM-3) compares the Demand signal with the output shaft position. When the DCM-3 detects a difference between Demand and Position (called error), the motor will rotate the output shaft until the Position matches the Demand.

## INSTALLATION

### Mechanical

The 11-489 actuator may be installed in any convenient orientation, because the gearing does not require an oil bath. Refer to the outline dimension drawings for physical dimensions and required clearances.

## VALVE INSTALLATIONS



### CAUTION

Working with valves and gates can be dangerous. Take appropriate precautions when mounting to installed valves or gates. Follow manufacturer precautions.

Whenever an actuator is being mounted on a valve, refer to the valve manufacturer's maintenance manual for specific valve-related instructions. *Consult the Beck Valve Mounting Specification sheet shipped with the actuator for specific instructions on assembly of the Beck actuator and mounting hardware to the gearbox or valve.* It is good practice to remove the valve from service if possible.

**WARNING**  
Lifting lugs should be used to lift the actuator **only** -- do not use the lugs to lift the actuator when attached to additional equipment such as a valve or gearbox.

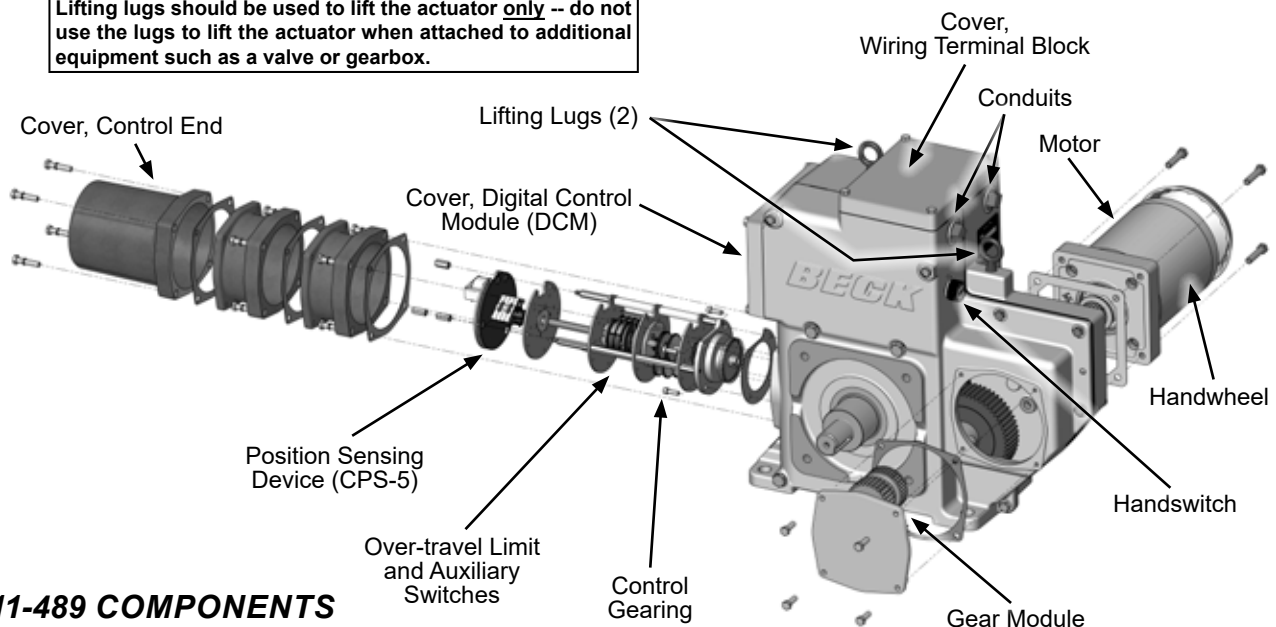

## 11-489 COMPONENTS

# INSTALLATION Electrical

## POWER QUALITY

Power quality disturbances such as power outages, transient voltages, harmonic distortions, and electrical noise will adversely affect your actuator performance. Protecting your actuator from these conditions can reduce downtime and promote longer life for the equipment. Following the industry accepted standards below will help protect your actuator.

- ✦ Select wiring materials according to the correct ampacity ratings dictated by national and local regulations.
- ✦ Shielded, twisted pair cables can be used for signal connections to avoid being affected by electrical noise. These signal wires, based on Noise Susceptibility Level (NSL) per IEEE-518, fall into the level 1 classification. A braided shield will be more effective than a wrapped foil shield. Signal wire shields should be connected to the actuator casting grounding screw. If grounding at the signal source is required, then the shield should not be grounded at the actuator.
- ✦ Raceways such as conduits and trays must be grounded at both ends to properly meet immunity requirements.
- ✦ An AC power ground connection should be made between the power source and the Beck actuator. Grounding connections including wire and metal conduit are permitted, but the actuator-grounding conductor may not be connected to a structured metal frame of a building.
- ✦ Surge suppression equipment that meets Underwriters Laboratory (UL) Standard 1449 may be used to protect against transient voltage conditions.
- ✦ Power Conditioners may be used to regulate the supply voltage and maintain a constant voltage level. They are helpful in protection against voltage sags and swells, as well as some measure of electrical noise protection.
- ✦ Harmonic filters may be used to minimize the effects of supply voltage waveform distortions and are used in applications that incur a large amount of high-frequency electronic noise.



### CAUTION

**Always close covers immediately after installation or service to prevent moisture or other foreign matter from entering the actuator.**

## ELECTRICAL INSTALLATION

Two 1" N.P.T. conduit connections are provided for power and signal wiring to the actuator. Conduits should be routed from below the actuator so that condensation and other contaminants flow away from the conduit. All conduit entrances must be properly sealed in accordance with National Standards or Regulatory Authorities.

Power and signal wires should be routed to the actuator separately and be either shielded cables or installed in conductive conduit and/or cable trays.

Refer to the wiring diagram furnished with your Beck actuator for proper AC power and signal connections. The customer must supply 120 Vac to power the actuator (standard configuration). The 120 Vac line connects to terminal C and neutral to terminal B. Other available power options include 208, 240 & 480 Vac.

It is advisable to provide normal short circuit protection on the AC power line. A copy of the wiring diagram is shipped with each actuator and is fastened to the inside of the terminal block cover. If there is no wiring diagram available, you may obtain a copy from Beck by providing the serial number of your actuator.

Connection of a 4-20 mA Demand signal should be made to terminals AA (+) and BB (-).

For maximum safety, the Beck actuator body should be grounded. Use the green grounding screw in the wiring compartment of the actuator.

## TERMINAL SCREW TORQUES

Each terminal screw should be torqued to the proper specification upon landing the wire.

Terminals	Torque	
	(lb-in)	(N•m)
A-V	16	1.8
AA-EE	12	1.4
FF-SS*	9	1.0
1-3*	20	2.3

\* Terminals included only with certain optional features.

# INSTALLATION Wiring

## TERMINAL CONNECTIONS

The terminal block is located in a separate, gasketed compartment at the top of the actuator. Line voltage connections are made on terminal designations A through V and are oriented at a right angle from the low voltage signaling terminals designated AA through EE.

Actuators equipped with optional transformers to accommodate popular voltages include an additional terminal strip and fuse for power wiring (with the exception of the 240 volt option). See optional transformer wiring connections below.

Terminal screws will accept standard spade or ring terminals. Terminals A through V are size #8, and terminals AA through EE are size #6. Optional transformer terminal screws (designated 1, 2, & 3) are size #10. For wiring versatility, the screw-down clamp design will also accept unterminated wire. All terminals will accept up to #12 AWG (3.31 mm<sup>2</sup>) except for optional transformer terminals (1–3) which will accept up to #10 AWG.

Typical wiring connections are shown below. Each actuator is equipped with four auxiliary switches (wiring connections are described in the Configuration/Calibration section).



To prevent Handswitch initiated motion, remove jumper (JA) from between terminals A and C.



**CAUTION**  
AC power to the actuator must be turned off before removing the jumper (JA).

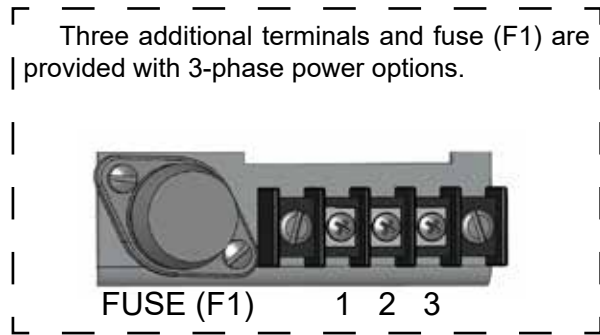

## TYPICAL WIRING CONNECTIONS

(Each actuator has a specific wiring diagram on the inside of the terminal compartment cover)

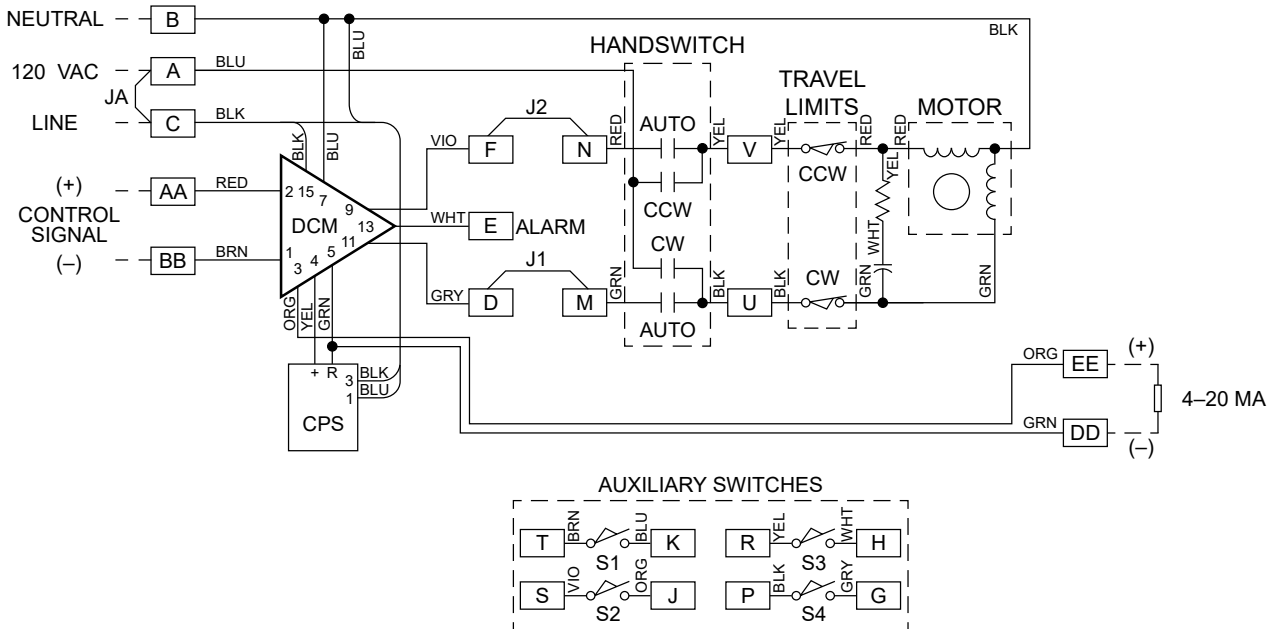

# INSTALLATION Wiring

# START-UP

## POWER CONNECTIONS FOR ALTERNATE POWER OPTIONS

Optional Transformer for  
480 Volts

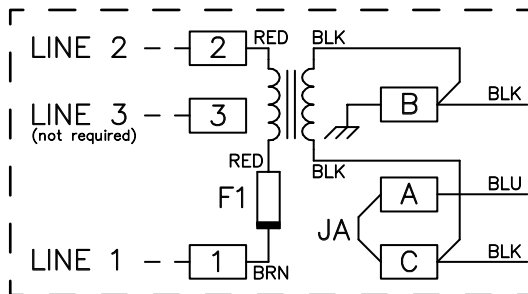

Optional Transformer for  
208 Volts

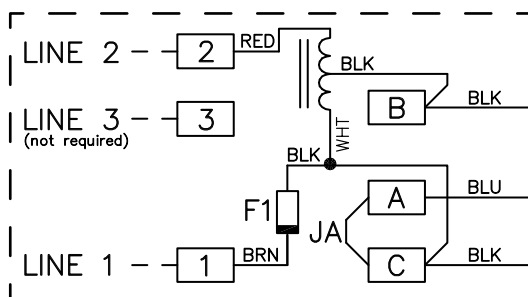

Optional Transformer for  
240 Volts

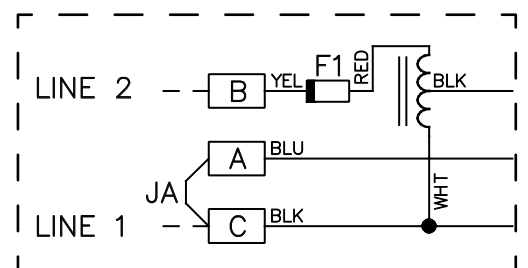

**NOTE:** All Beck actuators are shipped from the factory ready for installation. Each actuator is set-up and calibrated to the customer's specifications that were written into the equipment order. Electrical adjustments are generally not required before placing the actuator in operation.

## START-UP CHECKLIST

The following list provides some basic checks that should be performed before placing your actuator into operation.

- Inspect the location and the mounting bolts. Be sure the actuator is securely fastened to its mounting base.
- On the first start-up, place the Handswitch in a STOP position to ensure that the output shaft will not move and possibly cause personal injury.
- Confirm the actuator is receiving the appropriate operating voltage as shown on the nameplate.
- Check the DCM-3 Power LED. It should be pulsing (Dim/Bright) to indicate the board is active.
- Using the Handswitch, confirm the actuator moves fully to both the CW and CCW ends of travel.
- Confirm the actuator has a 4–20 mA Demand signal attached to terminals AA (+) and BB (-).
- Place the Handswitch in AUTO and vary your Demand signal from 0% to 100%.
- Check for the Status alarm LED on the DCM-3. If it is lit, refer to the Troubleshooting section of this manual.
- Verify that the output shaft is moving to the desired 0% position with a 0% Demand signal and moving to the 100% position with a 100% Demand signal. If they are reversed, see the Configuration/Calibration section of this manual for instructions on how to change the direction of output shaft rotation.

# ELECTRONICS

## CONTROL END & CONTACTLESS POSITION SENSOR (CPS-5)

The actuator “control end” houses the limit switch assemblies, the Contactless Position Sensor (CPS-5), and gearing. The CPS-5 is the electro-mechanical device that provides the DCM-3 with a continuous feedback signal proportional to the position of the actuator’s output shaft.

The control end includes a control shaft, which is geared directly to the output shaft of the actuator. Rotation of the output shaft causes rotation of the control shaft, which in turn moves the limit switch cams and the CPS-5 ferrite rotor. A ferrite magnetic sensing element generates a voltage as the rotor turns. The voltage is translated into a position signal voltage used by the DCM-3 to control the actuator.

The typical full range position signal voltage of the CPS-5 ranges from 1.0 Vdc at the CCW end of travel, to 5.0 Vdc at the CW end of travel. The DCM-3 can be calibrated to interpret CPS-5 position signals between 0.3 Vdc and 5.3 Vdc. Position signal voltages can be measured on the yellow (+) and green (R) position signal wires located on the CPS-5. The CPS-5 power is derived from the blue and black wires on the primary side of the transformer. 120 Vac can be measured across the transformer tabs (blue and black wires).

There are two SPDT over-travel limit switch assemblies (labeled “CW” and “CCW”) and four auxiliary switch assemblies (labeled “S1” through “S4”).

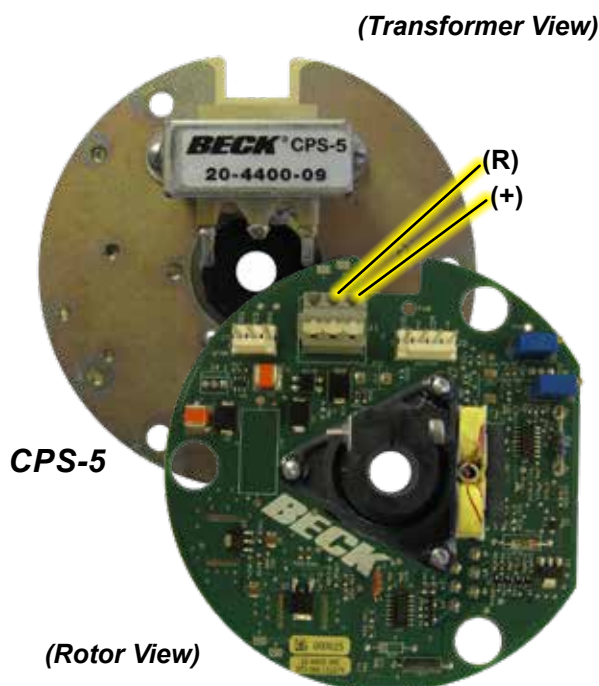

## DIGITAL CONTROL MODULE (DCM-3)

The DCM-3 is a micro-processor based circuit board assembly that serves as the actuator’s control center.

The main function of the DCM-3 is to position the actuator’s output shaft. The DCM-3 compares the 4–20 mA Demand signal received at the actuator terminals AA (+) and BB (–) to the actuator position signal, generated from the Contactless Position Sensor (CPS-5). If a difference exists (called error) between the Demand and position signals, the DCM-3 activates triacs that operate the motor. The motor drives the gear train and positions the output shaft until the difference is eliminated.

The DCM-3 is pictured below. The DCM-3 layout is illustrated on page 15 and shows the fuse and test point locations. The typical position signal voltage from the CPS-5 (measured from TP1(–) and TP4(+)) ranges from 1.0 Vdc at the CCW end of output shaft travel, to 5.0 Vdc at the CW end of output shaft travel. Test point voltage levels between TP2(+) and TP3(–) across the input resistor R11 should read between 1 Vdc and 5 Vdc proportional to the 4–20 mA Demand signal.



**DCM-3**

# ELECTRONICS

## INTERFACES

The DCM-3 has three configuration interfaces: Pushbutton, HART, and Serial Port.

### PUSHBUTTON

The DCM-3 board is equipped with pushbuttons that can be used to calibrate the Demand signal and configure 0% and 100% positions. It may also be used to configure the direction of output shaft rotation for increasing Demand. These configurations and calibrations do not require any external equipment to perform.

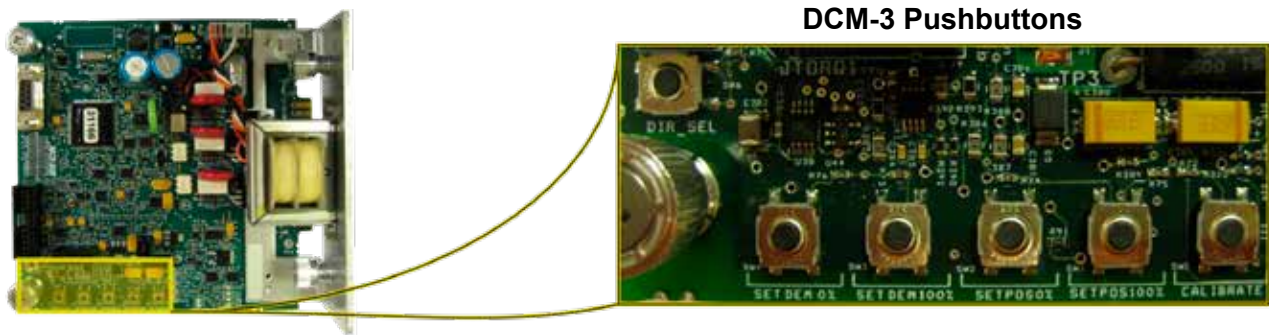

### HART

The HART interface is accessible by connecting a HART capable communication device (such as a handheld communicator) to terminals AA (+) and BB (-) of the terminal block area. A HART-capable, analog output can be used for the Demand signal as well. All electronic calibration and configuration can be accomplished through the HART interface. NOTE: The appropriate HART device descriptions are required.

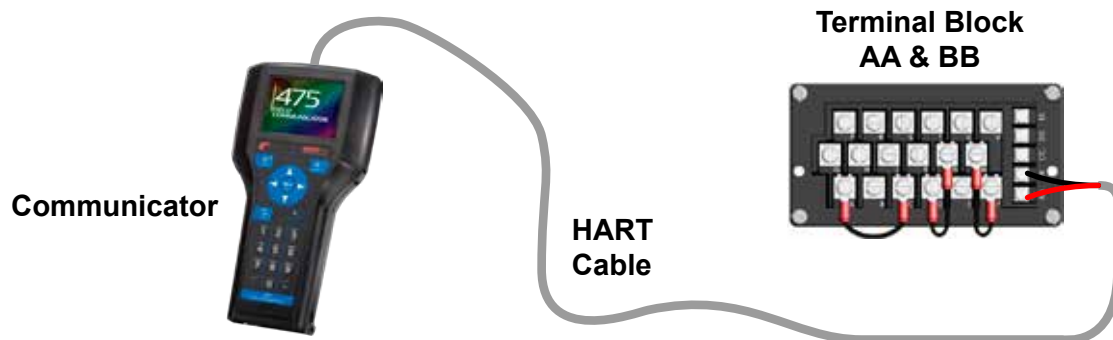

### SERIAL PORT

The Serial port interface is accessible by connecting a computer to the DCM-3 using the DB9 connector. See the Serial Communications appendix for details on connecting via the Serial port. All electronic calibration and configuration can be accomplished through the Serial port interface.



## DCM-3 LAYOUT

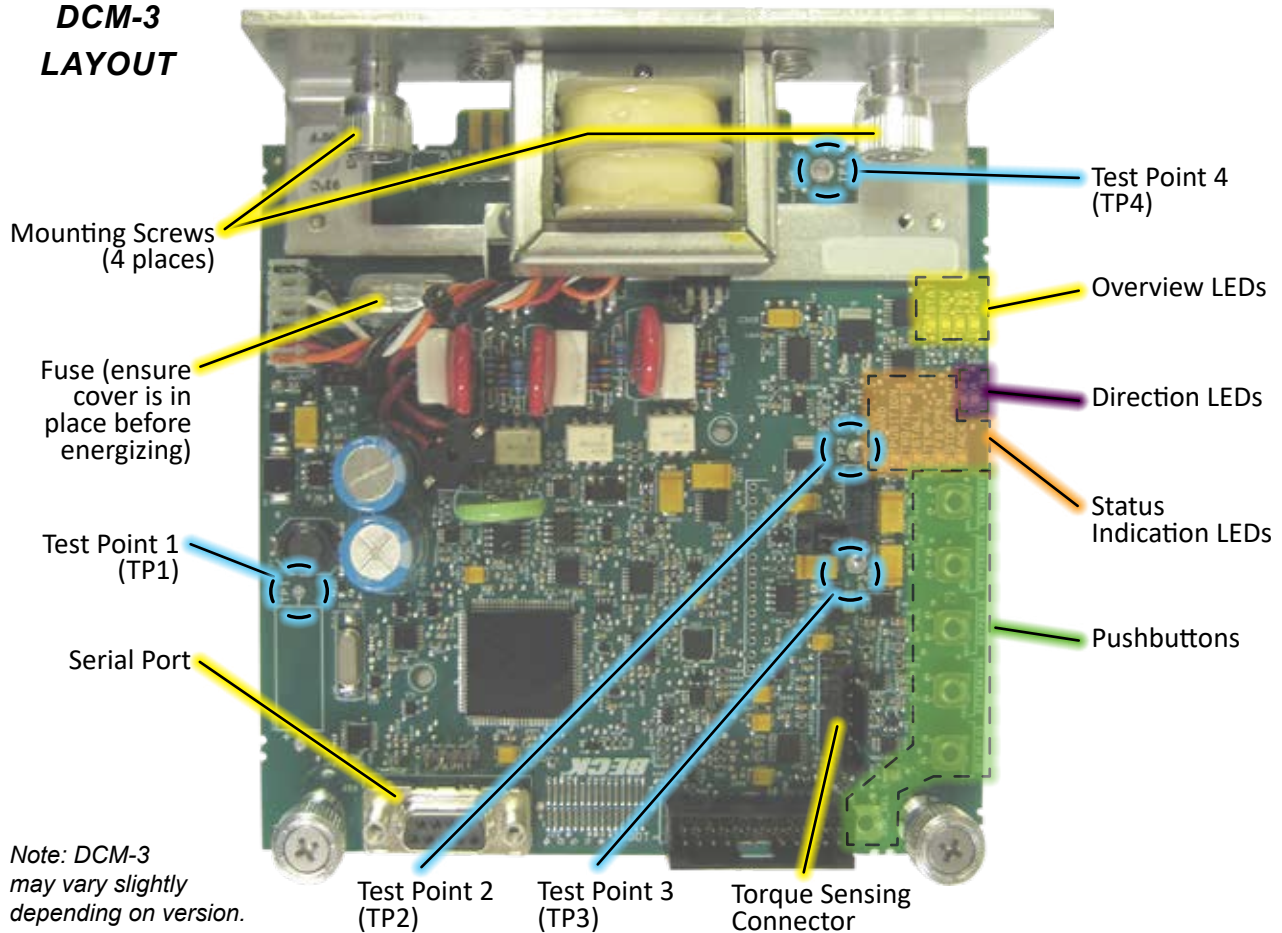

### OVERVIEW LEDs

Located on the DCM-3 board (pictured above), these LEDs indicate the basic, real-time state of the actuator. A description of each LED follows.

#### **STAT**

This red LED illuminates during a system alarm. Explanation of the specific alarm is available through the Fieldbus or Serial interface. See the Troubleshooting section for additional information.

#### **REV**

This green LED illuminates when the actuator is receiving a Demand signal less than its position.

#### **FWD**

This green LED illuminates when the actuator is receiving a Demand signal greater than its position.

#### **PWR**

This green LED illuminates when power is applied to the actuator. This LED pulses from bright to dim indicating the DCM-3 is operational.

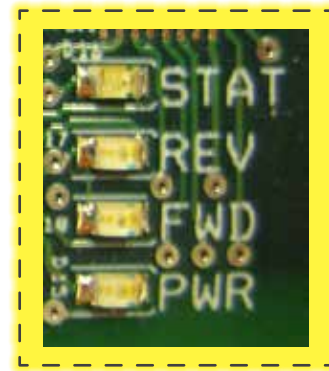

**OVERVIEW LEDs**

### DIRECTION LEDs

These green LEDs indicate the direction of travel resulting from an increasing Demand signal.

**DIRECTION  
LEDs**

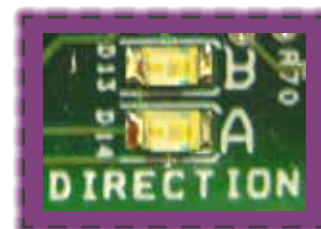

**A = CCW    B = CW**

# ELECTRONICS

## STATUS INDICATION LEDs

When the "STAT" LED is lit, the applicable red indication LED(s) will light to reveal the actuator condition(s). An alarm is also available at terminal E. When the condition is corrected, the status will automatically reset.

### DEMAND

Loss of the Demand input signal.

### POSITION

The Position signal to the DCM-3 is out of the calibrated range limits. The lower limit is -5% and the upper limit is 105% of the calibrated range. May also indicate a film potentiometer or internal wiring failure.

### TRQ/THRST

Not applicable to the 11-489.

### STALL

The actuator is in a stall condition and stall protection has been activated.

### TEMP °F.

Drive's internal temperature is outside of rating.

### FB OPEN

External position Feedback signal is enabled, but not wired to an external load or the wiring has failed between the actuator and the monitoring device.

### STOP/LIMIT

Handswitch is in "STOP" position or the actuator is at a limit and is not in balance.

### ACK

Acknowledges when a calibration procedure has been completed.

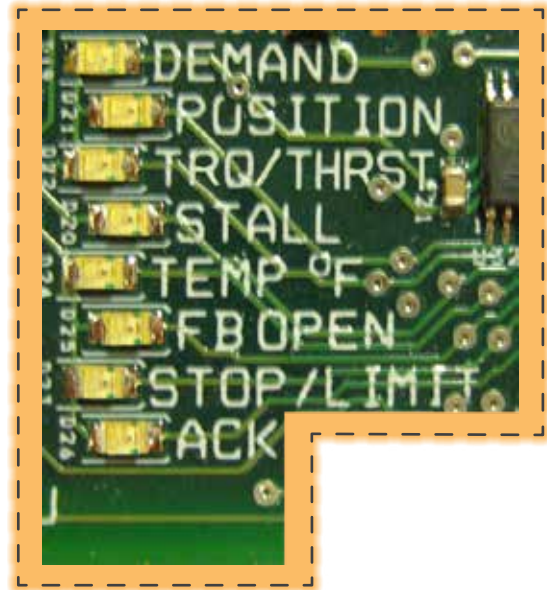

**STATUS INDICATION LEDs**

## PUSHBUTTON CONTROLS

The six pushbuttons (pictured below) on the DCM-3 customer interface panel are used for calibration. When pressing a pushbutton, pressure should be maintained until the "ACK" LED is lit; this confirms receipt of the pushbutton command. See the Configuration/Calibration section of this manual for further explanation of calibration procedures.

### CALIBRATE

This button must be pressed and held simultaneously with another pushbutton to perform a calibration.

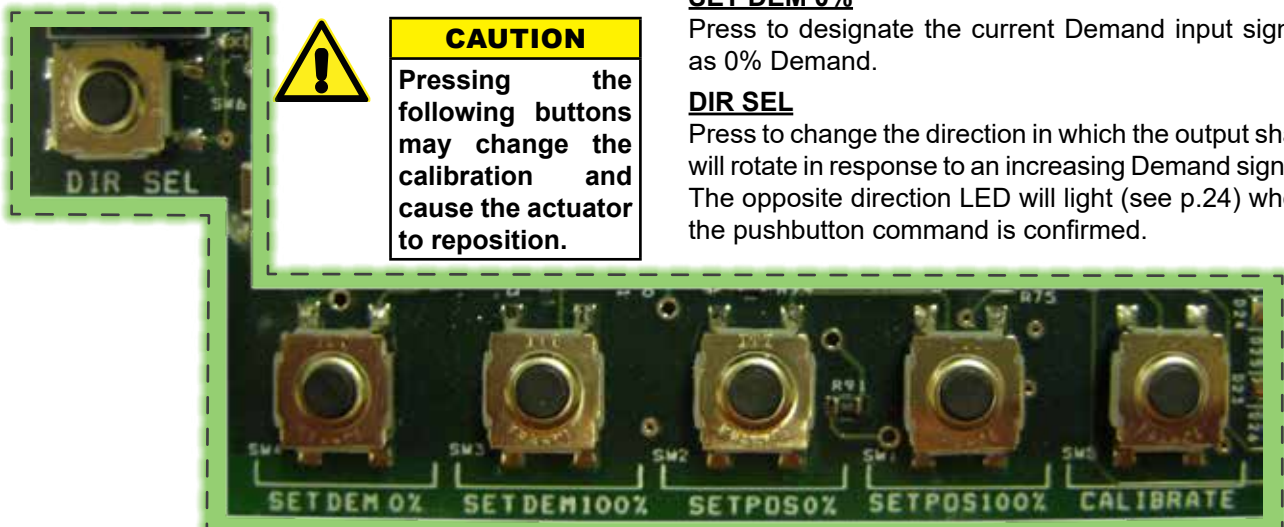

**PUSHBUTTON CONTROLS**

### SET POS 100%

Press to designate the current position of the output shaft as the 100% position for actuator movement (this will correspond to a 100% Demand signal).

### SET POS 0%

Press to designate the current position of the output shaft as the 0% position for actuator movement (this will correspond to a 0% Demand signal).

### SET DEM 100%

Press to designate the current Demand input signal as 100% Demand.

### SET DEM 0%

Press to designate the current Demand input signal as 0% Demand.

### DIR SEL

Press to change the direction in which the output shaft will rotate in response to an increasing Demand signal. The opposite direction LED will light (see p.24) when the pushbutton command is confirmed.

# CONFIGURATION/CALIBRATION

**NOTE:** Your Beck actuator was shipped from the factory ready for installation; no electrical adjustments are required before placing it in operation. Each actuator is set up and calibrated to the specifications that were written into the equipment order.

Under normal operating conditions there is no need to recalibrate the actuator. However, if the application requirements change—or are different than specified on the equipment order—the actuator should be recalibrated according to the following procedures.

## LIMIT SWITCHES

Actuators are shipped with over-travel limit switches factory-set just outside the full travel limits (as shipped). Limit switches can be reset to protect against over-travel of the output shaft when the actuator position calibration has been reduced. See the calibration procedure on page 22. Auxiliary switches are set as shown on the Standard Over-travel Limit and Auxiliary Switch Settings diagram on page 18 unless otherwise specified at time of order.

**NOTE:** The over-travel limit switches are the switches closest to the actuator body. To adjust the over-travel limit switches, it is necessary to remove the control end cover.

Switches are operated by cams which are clamped onto the control shaft. Setting a switch involves loosening the cam, moving the output shaft to the desired position, and positioning the cam so that it just operates the switch at that point. In the following procedure, the use of a continuity meter is recommended to determine when the switch opens or closes. If such a meter is not available, it is possible to hear the switch click as the contacts open and close.



### CAUTION

**Do not attach the meter or attempt to move the switch cams until the actuator is disconnected from the line voltage and auxiliary switches are disconnected from external power sources.**

## SETTING OVER-TRAVEL LIMIT SWITCHES CW AND CCW

This procedure should be used if the factory over-travel limit switch settings must be changed in the field. It is advisable to operate the actuator fully in each direction, using the electric Handswitch to check switch settings before attempting to change them. Follow these instructions if they require adjustment:

1. Remove the control end cover and terminal block cover (1/2" wrench).
2. Use the electric Handswitch to drive the control shaft so that the CW switch cam screw is accessible. Using a 7/64" hex wrench, loosen the screw so that the cam is just snug on the shaft (see illustration, page 18).
3. Move the output shaft to the desired CW limit.
4. Turn the Handswitch to the "STOP" position.
5. **Disconnect power from the actuator.**
6. Connect a continuity meter across terminals B and U. Rotate the cam until the meter shows no continuity (switch contacts open, switch clicks).
7. Tighten the cam locking screw to 5 lb-in (0.56 N•m) torque.
8. Disconnect meter and ensure the Handswitch is in the "STOP" position.
9. Reconnect actuator power.
10. Rotate the actuator's output shaft in the CCW direction away from the CW travel limit. Note the direction of rotation on the lobe of the cam. The correct cam lobe motion is away from the switch lever with the switch lever on the lower part of the cam. If not correct, return to step 2 and reset the cam to the proper orientation.
11. Rotate the output shaft again to the desired CW travel limit. If the stopping point is reached, the switch is properly set.
12. Repeat instructions 2–11 for setting the CCW travel limit switch (noting that referenced directions of rotation should be opposite of those used for CW switch setting). Connect continuity meter across terminals B and V.
13. Replace covers and tighten cover bolts to 10 lb-ft (14 N•m) torque.

# CONFIGURATION/CALIBRATION

## SETTING AUXILIARY LIMIT SWITCHES

Standard switch settings for the 4 auxiliary switches are shown on the following diagram “Standard Over-travel Limit and Auxiliary Switch Settings”. The heavy line indicates a closed circuit. Follow these instructions to change the operating point of auxiliary switches:

**NOTE: It may be necessary to change from normally open to normally closed by moving the wire lead to alternate switch terminals. Be sure to disconnect power from the switch terminals first.**

1. Remove the control end cover and the terminal block cover (1/2" wrench).
2. Use the electric Handswitch to drive the shaft so that the switch cam is accessible. Using a 7/64" hex wrench, loosen the screw so that the cam is just snug on the shaft.
3. Move the output shaft to the desired switch trip position.
4. Turn the Handswitch to the “STOP” position.
5. **Disconnect power from the actuator and switch terminals.**
6. Connect the continuity meter across the appropriate terminals. See the actuator wiring diagram under the terminal block cover (or the diagram at right). Rotate the cam to operate the switch.
7. Tighten the cam locking screw to 5 lb-in (0.56 N•m) torque.
8. Disconnect the meter and reconnect power.
9. Move the actuator's output shaft in the desired direction to verify that the cam lobe moves away from the switch lever. If not correct, return to step 2 and reset the cam to the proper orientation.
10. Replace covers and tighten cover bolts to 10 lb-ft (14 N•m) torque.

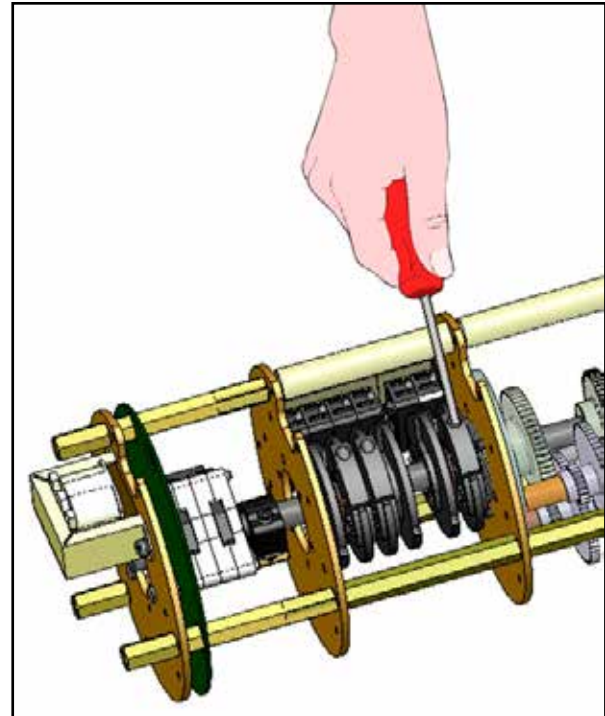

**SWITCH CAM ADJUSTMENT**

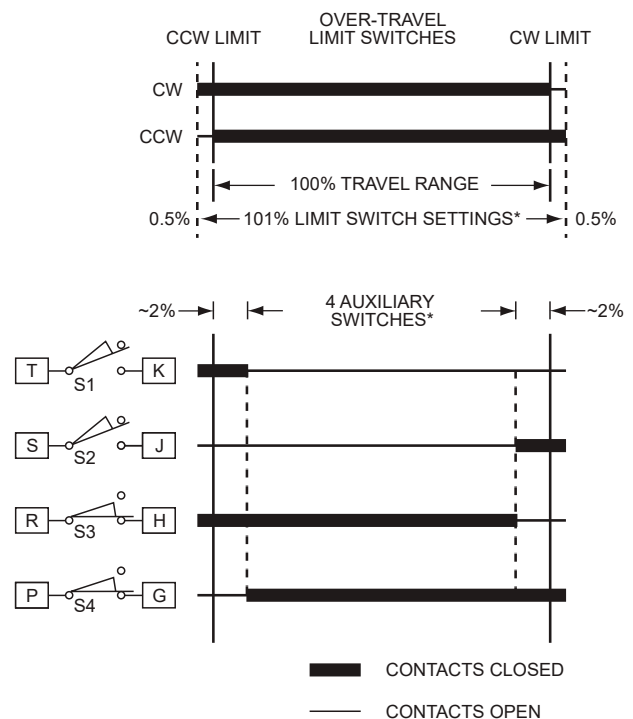

\*Shown as shipped - user configurable

**TYPICAL OVER-TRAVEL LIMIT AND  
AUXILIARY SWITCH SETTINGS**

## DIRECTION OF OUTPUT SHAFT ROTATION

Rotation direction refers to the direction the output shaft of the actuator rotates in response to an increasing Demand input signal. The rotation is either clockwise (CW) or counterclockwise (CCW) as shown in the figure below. The rotation of the driven load (e.g., damper lever arm) determines the actuator rotation suitable for an application.

Unless otherwise specified at the time of order, the output shaft is factory set to rotate clockwise in response to an increasing Demand signal. The direction of rotation can be changed using one of the following three methods.

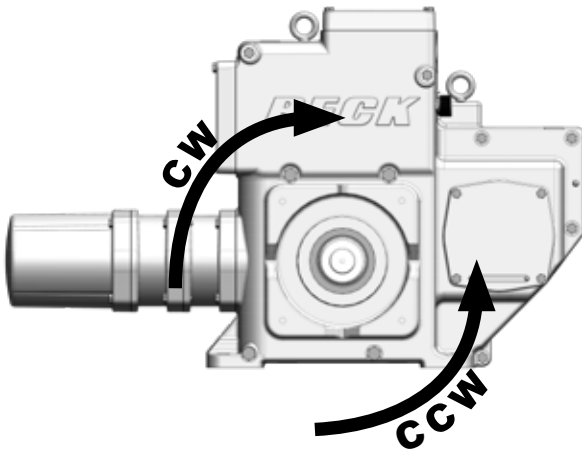

### Pushbutton method

1. Remove the DCM-3 cover (1/2" bolt heads).
2. Press and hold the "CALIBRATE" pushbutton, then press the "DIR SEL" pushbutton until the (opposite) "DIRECTION" LED is lit.

—OR—

2. Position the actuator at the current 0% position.
3. Press and hold the "CALIBRATE" pushbutton, then press the "SET POS 100%" pushbutton until the "ACKNOWLEDGE" LED is lit.\*

—OR—

2. Position the actuator at the current 100% position.
3. Press and hold the "CALIBRATE" pushbutton, then press the "SET POS 0%" pushbutton until the "ACKNOWLEDGE" LED is lit.\*
4. Ensure the actuator operates as desired.
5. Replace the DCM-3 cover and tighten the cover bolts to 10 lb-ft (14 N•m) torque. Reset travel index.

\* If the "ACKNOWLEDGE" LED does not light, but the "POSITION" LED does light, the change was not accepted by the DCM-3.

**NOTE:** When any of the above procedures is performed, both the 0% and 100% positions are automatically set.

### HART method

**Command:** Drive Dir

**DD Menu Location:** MENU 4B

Functions>Configuration>General Setup

**Selections:**

**CW Incr** - select if the desired output shaft rotation is clockwise on increasing Demand signal.

**CCW Incr** - select if the desired output shaft rotation is counter-clockwise on increasing Demand signal.

### Serial command method

**Command:** drvdir *n*

**Arguments:** *n*

**0:** CW - select if the desired output shaft rotation is clockwise on increasing Demand signal.

**1:** CCW - select if the desired output shaft rotation is counter-clockwise on increasing Demand signal.

# CONFIGURATION/CALIBRATION

## STEP SIZE

Step size represents the minimum amount that the Demand signal must change to initiate a change in actuator position.

When the actuator is in AUTO mode, the DCM-3 runs the motor until the output shaft position matches the percentage of Demand signal. When they match, power is removed from the motor. The Demand signal must change by the step size before power is returned to the motor.

The step size is factory set to 0.15% of full travel span, unless otherwise specified at the time of order. The step size is adjustable from 0.1% to 2.5% when the actuator is configured for 100 degrees of travel. Adjustment is typically not required. The minimum step size regardless of travel is 0.1°.

It may be advantageous in certain applications, where noise or other problems exist, to increase the step size slightly to prevent excessive modulation.

The step size can be changed using the following methods.

**NOTE: Changing this parameter online could cause the actuator to reposition.**

### HART method

**Command:** StepSize

**DD Menu Location: MENU 4B**

Functions>Configuration>General Setup>

Enter the desired step size between "0.10%" and "2.50%".

### Serial command method

**Command:** stepsize #.##

**Arguments:** #.## Desired step size (in degrees) of one incremental movement of output shaft travel. Acceptable range is between "0.10" and "2.50".

## RESTORE FACTORY SETTINGS

All DCM-3's are shipped from the factory configured per the customer instructions at the time of order. A complete copy of the factory configuration is stored on the DCM-3. You can revert to the factory settings at any time using one of the following methods.

**NOTE: When the factory settings are restored, the Operation Mode (HART DD menu location 3E or Serial command "opmode") will not be changed for safety reasons. The operation mode should be set to "Follow" for normal automatic operation.**

### HART method

**Command:** Restore to Factory

Running this function will restore all configurable parameters to the original factory settings.

**DD Menu Location: MENU 3C**

Functions> Configuration

### Serial command method

**Command:** restoremodes *n*

**Arguments:** *n*

**1:** Used as a safety measure, the number one must be entered as an argument to prevent someone from running the restoremodes command errantly.

## TRAVEL (TURNS / DEGREES ROTATION)

Travel is defined as the number of full output shaft turns (revolutions) or by degrees of rotation between the 0% and 100% positions.

Unless otherwise specified, the 11-489 is factory configured for the maximum travel allowable (dependent upon actuator setup -- see Table below).

It is possible to change the full travel of the actuator output shaft to suit application requirements. It is recommended that travel is set to at least 50% of span for the best positioning performance. To set the Beck output shaft full range of rotation, electronic calibration changes can be made by using one of the two procedures below. These procedures can be performed by using the methods that follow.

- 1. 0% and 100% Position Calibration:** Physically drive the actuator to the new 0% and 100% positions. Use the Pushbutton or HART method to set the new end points (see page 22).
- 2. Changing Travel in Turns or Degrees:** This allows the calibration to be changed without moving the actuator output shaft. Use the HART or Serial command method to set the desired full travel rotation in turns or degrees (see page 22)\*. The 0% position will remain the same, but the 100% position will change to accommodate the new travel setting.

*\*Note: Unit of preference (turns or degrees) can only be set using the Serial command "travel"; HART recognizes degrees only.*

**NOTE:** In addition to recalibrating the electronics, the CW / CCW over-travel switches should also be adjusted to open just beyond the new electronic limits; this ensures that manual operation with the Handswitch will not cause over-travel or create a stall condition.

Minimum Travel		Maximum Travel		~ MAXIMUM STROKE TIME (mins.)	
Turns	Degrees	Turns	Degrees	90 lb-ft (122 N•m) 9.1 rpm* @ 60 Hz	120 lb-ft (122 N•m) 6.7 rpm* @ 60 Hz
5	1800	9	3240	1.0	1.3
7	2520	14	4680	1.5	2.1
14	4680	25	9000	2.7	3.7
25	9000	45	16200	4.9	6.7
35	12600	70	24480	7.7	10.4
65	23400	126	45360	13.8	18.8
115	41400	227	81720	24.9	33.9
200	72000	408	146880	44.8	60.9

# CONFIGURATION/CALIBRATION

## Calibrate the 0% and 100% positions:

### Pushbutton method

1. Move the output shaft to the desired 0% position.
2. Press and hold the “CALIBRATE” pushbutton then press the “SET POS 0%” pushbutton until the “ACKNOWLEDGE” LED is lit.
3. Move the output shaft to the desired number of turns to reach 100% travel.
4. Press and hold the “CALIBRATE” pushbutton then press the “SET POS 100%” pushbutton until the “ACKNOWLEDGE” LED is lit.
5. Adjust over-travel limit switches as necessary to accommodate the new rotation.

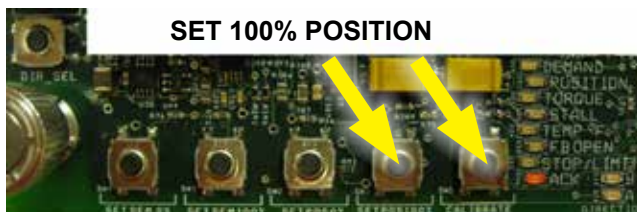
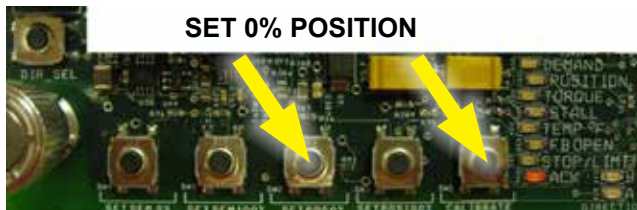

## Change Travel (Turns or Degrees):

### HART method

**Command:** Travel

Enter the desired full stroke rotation in degrees.

**HART DD Menu Location:** MENU 4B

Functions>Configuration>General Setup>

### Serial command method

**Command:** travel ###

**Arguments:** ### The desired full-stroke rotation in turns or degrees.

### HART method

**Command:** Set Pos 0%

Select when the output shaft is at the desired 0% position.

**Command:** Set Pos 100%

Select when the output shaft has traveled the desired number of turns to reach the 100% position.

**DD Menu Location:** MENU 4C

Functions>Configuration>PositionSensrSetup>

## DEMAND CALIBRATION

DCM-3 boards are designed to accept a 4–20 mA (or 1–5 Vdc) analog Demand signal. The input comes calibrated from the factory for the full range unless otherwise specified by the customer. It is not necessary to calibrate the Demand input when the actuator is installed; however, if the Demand needs to be calibrated to accommodate unusual operating conditions, two guidelines must be followed: First, the value for 0% must be greater than 0.5 mA and the value for 100% must be less than 21 mA. Second, the difference between 0% and 100% (minimum span) must be at least 4 mA. Use any of the following methods to calibrate Demand. Actuators may also be configured for split-range operation—contact the factory for details.

### **Calibrate the 0% and 100% Demand signal:**

#### **Pushbutton** method

1. Ensure the Handswitch is in the “STOP” position. This will prevent the actuator from repositioning during this procedure.
2. Apply the desired 0% Demand input signal to the actuator (e.g., 4 mA for 4–20 mA signal).
3. Press and hold the “CALIBRATE” pushbutton, then press the “SET DEM 0%” pushbutton until the “ACKNOWLEDGE” LED is lit.\*
4. Apply the desired 100% Demand input signal to the actuator (e.g., 20 mA for 4–20 mA signal).
5. Press and hold the “CALIBRATE” pushbutton, then press the “SET DEM 100%” pushbutton until the “ACKNOWLEDGE” LED is lit.\*
6. Turn the Handswitch to the “AUTO” position. NOTE: The actuator may reposition.
7. Run the actuator through its full operational range to ensure proper response to the Demand input signal.
8. Replace the compartment covers and tighten the cover bolts to 10 lb-ft (14 N•m) torque.

\*If the “ACKNOWLEDGE” LED does not light, but the “Demand” LED does light, the calibration is out of acceptable range and was not accepted by the DCM-3. This is typically caused by trying to set 0% and 100% values too close together (i.e., less than 4 mA difference).



#### **HART** method

**Command:** DemRngLwr

Enter the desired 0% Demand signal ("4.00" to "16.00" mA).

**Command:** DemRngUpR

Enter the desired 100% Demand signal ("8.00" to "20.00" mA).

**DD Menu Location:** MENU 4D

Functions>Configuration>Demand Setup>

#### **Serial** command method

**Command:** dem0pctma #.##

**Arguments:** #.## Desired 0% Demand signal ("4.00" to "16.00" mA).

**Command:** dem100pctma #.##

**Arguments:** #.## Desired 100% Demand signal ("8.00" to "20.00" mA).

# CONFIGURATION/CALIBRATION

## LOSS OF DEMAND SIGNAL (LOS)

The DCM-3 is capable of determining if the Demand input signal to the actuator is outside of an acceptable range. The DCM-3 uses a configurable loss of signal (LOS) threshold to determine if the Demand signal falls below a minimum value. Unless otherwise specified in the original order, the factory-set threshold is 3.2 mA. When the DCM-3 senses an LOS condition, an alarm condition will result, illuminating the "Demand" status indication LED. The actuator then responds according to the LOS setting. The DCM-3 can be configured for one of two LOS actions:

1. **Stay in Place**—the actuator output shaft stays in place until the Demand signal returns to the acceptable range. This is the factory default.
2. **Go-to-Position**—the actuator output shaft will move to a preset position, designated in percentage of travel. For example, if the LOS action is set for 50%, the actuator output shaft will drive to the 12 mA position (based on a 4-20 mA span).

The LOS parameters can be configured using HART or Serial commands.



### CAUTION

The following procedures could cause the actuator to reposition, which can adversely affect the process and cause potentially dangerous conditions.

### Configure the LOS threshold:

#### HART method

**Command:** DemLimLwr  
Enter "0.00" to "12.00" mA. Decimal value of the lower threshold for detecting LOS. (e.g., the typical value for a 4–20 mA system is "3.20").

**DD Menu Location:** MENU 4D  
Functions>Configuration>Demand Setup>

#### Serial command method

**Command:** demlos ###

**Arguments:** ### Enter the desired Demand signal in mA below which LOS occurs (e.g., the typical value for a 4–20 mA system is "3.20").

### Configure the LOS mode:

#### HART method

**Command:** LOS Mode

**DD Menu Location:** MENU 4D  
Functions>Configuration>Demand Setup>

#### Selections:

**Stay** - select if the actuator should hold output shaft position when a loss of signal occurs.

**Go-to-Pos** - select if the output shaft should go to a specific position when a loss of signal condition occurs. Configure the position with LOS Pos.

#### Serial command method

**Command:** demlos *n*

**Arguments:** *n* Enter the desired mode

**sip:** (actuator will stay in place).

**gtp:** (actuator will go to position set in "demlogtp" command)

**pat:** (same as "sip", but suppresses the alarm).

### Configure the LOS position when Go-to-Pos is selected:

#### HART method

**Command:** LOS Pos  
Enter "-5.00%" to "105.00%". The percentage of full travel the actuator will move upon LOS.

**DD Menu Location:** MENU 4D  
Functions>Configuration>Demand Setup>

#### Serial command method

**Command:** demlogtp ###.###

**Arguments:** ###.### Desired position of actuator if "gtp" is selected in "demlos". Position is expressed as a percentage of actuator travel in decimal form (e.g., 50% = "50.00").

**Command:** demlogtp delay *n*

**Arguments:** *n* Time delay in seconds before the actuator will move to the position set in "demlogtp" (0 to 25.5 seconds). Default is "0".

Entering this command without an argument will return the present GTP and delay settings.

## POSITION FEEDBACK SIGNAL

DCM-3 control electronics provide a 4–20 mA analog output signal that represents the actuator output shaft position. The DCM-3 monitors an internal position voltage from the CPS-5, controls the actuator position, and sources a 4–20 mA signal to terminals DD (–) and EE (+). The Feedback will correspond with the 0% and 100% output shaft positions, as determined by the position calibration (page 22). **There is no need for separate Feedback calibration.**

The user has the option of enabling or disabling the position Feedback signal. The factory default configuration will have the Feedback enabled. When the Feedback is enabled, but not in use (i.e., not wired to a load) the "STAT" and "FB OPEN" LEDs will illuminate. This status alarm is helpful in alerting the user to open Feedback wiring, but can be a nuisance when the Feedback is purposely disconnected or unused. Disabling the Feedback signal turns off the output and eliminates the status alarm. If HART or Serial communications are not immediately available to disable the Feedback signal, you can apply a 250 ohm load resistor across the Feedback terminals DD (–) and EE (+) to simulate a Feedback loop and eliminate the alarm.

Use the HART or Serial Commands (detailed on the next page) to set the Feedback signals and corresponding output shaft positions as detailed below.

If desired, the milliamp position Feedback values for 0% and 100% positions can be configured differently than the respective standard factory calibration of 4 mA and 20 mA. A valid 0% position Feedback signal value can be configured anywhere in a 3–16 mA range, while a 100% signal value can be configured from 7–21 mA. The 100% milliamp value must exceed the 0% value by at least 4 mA.

Also, reversed (decreasing direction) Feedback may be selected so that the position resulting from a 4 mA Feedback signal corresponds to the position typically resulting from a 20 mA signal; e.g., 4 mA = 100% position and 20 mA = 0% position. Setting the 0% position to 20 mA will automatically set the 100% position to 4 mA (and vice-versa), and will activate the reverse (decreasing) Feedback function. After accepted, these settings may then be changed as detailed in the paragraph above, only opposite; i.e., a valid 0% position Feedback value is 7–21 mA, while a 100% position may be set at 3–16 mA. The difference between the values can be no less than 4 mA and no greater than 18 mA.

The factory calibrated relationship between the position Feedback signal and the output shaft position is linear (i.e., 0% to 100% Feedback signal corresponds directly with 0% to 100% shaft position). This relationship is suitable for most applications; however, the Feedback to Demand relationship can be changed to compensate for characterized Demand signals. This relationship is called "Inverse Demand". Configuring this option allows the position Feedback signal to match the uncharacterized Demand signal rather than true output shaft position.

The following example assumes 4–20 mA Demand and position signals. If the Demand is set to a square characterization, then a 12 mA Demand corresponds to 25% position. If the position Feedback curve is set to linear, then Feedback at 25% is 8 mA. For some control systems, having the Demand at 12 mA and the Feedback at 8 mA may cause a deviation alarm. The Feedback curve can be set to "Inverse Demand" so the Demand and Feedback match when the actuator is balanced. In this example, with Feedback set to "Inverse Demand" and the output shaft position at 25%, the Feedback signal would be 12 mA.

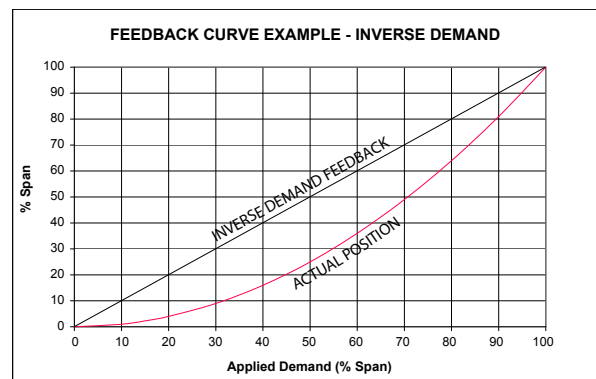
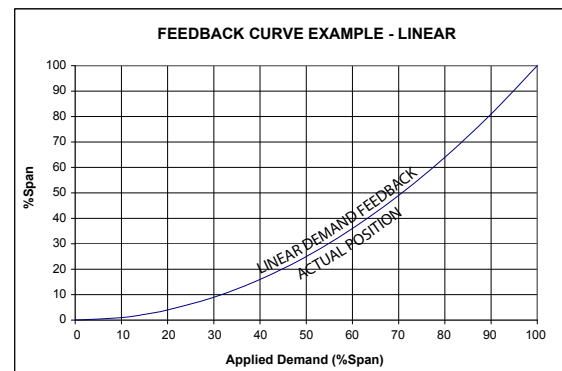

# CONFIGURATION/CALIBRATION

The following methods describe how to enable or disable position Feedback, set the 0% and 100% milliamp values and select the desired Feedback response.

## Enable/disable the position feedback:

### **HART** method

**Command:** Feedback

**DD Menu Location:** MENU 4E

Functions>Configuration>Feedback Setup>

**Selections:**

**Enabled** - to enable position Feedback.

**Disabled** - to disable position Feedback.

### **Serial** command method

**Command:** iomode *n*

**Arguments:** *n*

**0:** Feedback disabled.

**1:** Feedback enabled.

## Set the feedback range lower and upper values:

### **HART** method

**Command:** FB RngLwr

Enter the milliamp value that corresponds with 0% position. Acceptable range "3.00"–"16.00" (typically, "4.00"). If reversed, the acceptable range is "7.00"–"21.00" (typically, "20.00").

**Command:** FB RngUp

Enter the milliamp value that corresponds with 100% position. Acceptable range "7.00"–"21.00" (typically, "20.00"). If reversed, the acceptable range is "3.00"–"16.00" (typically, "4.00").

**DD Menu Location:** MENU 4E

Functions>Configuration>Feedback Setup>

### **Serial** command method

**Command:** fdbk0pctma #.##

**Arguments:** #.## Desired Feedback signal in mA at 0% output shaft position. The value limit may be no less than "3.00" or, if reversed (decreasing direction), no greater than "21.00".

**Command:** fdbk100pctma #.##

**Arguments:** #.## Desired Feedback signal in mA at 100% output shaft position. The value limit may be no greater than "21.00" or, if reversed (decreasing direction), no less than "3.00".

## Set the feedback characterization curve:

### **HART** method

**Command:** FB Curve

**DD Menu Location:** MENU 4E

Functions>Configuration>Feedback Setup>

**Selections:**

**Linear** - to enable a linear feedback signal

**InvDem** - to enable an inverted Demand feedback signal.

### **Serial** command method

**Command:** fdbkfunc *n*

**Arguments:** *n*

**0:** Linear Feedback signal.

**1:** Inverse Demand Feedback signal.

## TEMPERATURE SENSING

DCM-3s are equipped with an internal temperature sensing circuit. The real-time temperature and the historical temperature extremes (low and high) are available.

Temperature units can be selected to show either Fahrenheit or Celsius.

An alarm condition initiates if the actuator's real-time temperature falls outside the actuator rating (see "General Specifications", page 4). The STAT LED and the TEMP F LED will light, and will automatically reset when the temperature is once again within the actuator rating.

### View real-time temperature & historical extremes:

#### **HART** method

**Command:** Temp

Displays the real-time temperature as read by the DCM-3.

**DD Menu Location:** MENU 1

**Command:** High Temp

Displays the historical high temperature.

**Command:** Low Temp

Displays the historical low temperature.

**DD Menu Location:** MENU 3D

Functions>Statistics

#### **Serial** command method

**Command:** temperature

**Arguments:**

When entered with no argument, the command returns the real-time temperature as well as the historical high and low temperatures.

### Set temperature units:

#### **HART** method

**Command:** Temperature Unit

**DD Menu Location:** MENU 4B

Functions>Configuration>General Setup

**Selections:**

**degF** - Set the temp. units to degrees Fahrenheit.

**degC** - Set the temp. units to degrees Celsius.

#### **Serial** command method

**Command:** temperature *n*

**Arguments:** *n*

**F:** Set the temp. units to degrees Fahrenheit.

**C:** Set the temp. units to degrees Celsius.

# CONFIGURATION/CALIBRATION

## STALL PROTECTION

The DCM-3 board provides protection for the actuator in the event of a stall. Stall protection is activated when the actuator is unable to achieve the proper position within a defined stall time due to a mechanical impediment or excessive load.

The DCM-3 senses when the motor moves the output shaft in one direction longer than the configured "stall time". The DCM-3 then shuts off power to the motor, preventing further actuator movement. When the stall condition occurs, the STAT LED will illuminate.

Resetting due to a stall condition is achieved by reversing the Demand signal, cycling the actuator power, or submitting a reset command via HART or Serial port.

The stall protection feature can be enabled or disabled and the stall time may be configured between 30 and 3,600 seconds. This feature is factory enabled and the default setting is 3,600 seconds. If changing the setting, it must be set to a stall time greater than the maximum stroke time to avoid false stall protection events and alarms.

### Enable / disable stall protection:

#### **HART** method

**Command:** StallProt

**DD Menu Location:** MENU 4B

Functions>Configuration>General Setup>

**Selections:**

**Enabled** - to enable stall protection.

**Disabled** - to disable stall protection.

#### **Serial** command method

**Command:** stallprot *n*

**Arguments:** *n*

**0:** stall protection disabled.

**1:** stall protection enabled.

### Configure the stall time:

#### **HART** method

**Command:** Stall Time

Enter the stall time in seconds. Valid stall times are 30 to 3600 seconds.

**DD Menu Location:** MENU 4B

Functions>Configuration>General Setup>

#### **Serial** command method

**Command:** stalltime ###

**Arguments:** ### Enter the stall time in seconds. Valid stall times are "30" to "3600".

### Reset a stall condition:

#### **HART** method

**Command:** Reset Stall

Select to reset a stall condition.

**DD Menu Location:** MENU 3E

Functions>Manual Operation>

#### **Serial** command method

**Command:** unSTALL

Enter to reset a stall condition.

# MAINTENANCE

## MOTOR ASSEMBLY

The control motor is not field-repairable. **Do not disassemble the motor.** Disassembly of the motor will result in a loss of torque that can only be restored by returning the motor to the factory for re-magnetizing.

Motor assembly replacement instructions follow:



### WARNING

**Disconnect power before proceeding.**

**Before removing the motor assembly, block the crank arm (if applicable) to prevent the crank arm and gear train from moving when the motor is removed.**

### REMOVE THE MOTOR ASSEMBLY:

Disconnect the motor wires in the terminal compartment of the actuator. The terminal block and barrier plate should be removed as an assembly from the actuator body to access the wires beneath.

After lifting the barrier plate assembly, the three motor wires may now be disconnected. Remove the black motor wire from the terminal "B" post, cut the red motor wire near the red-yellow-red butt joint and disconnect the green wire from the motor capacitor. Remove the mounting screws and then carefully slide the motor assembly out of the actuator body.

### INSTALL THE NEW MOTOR ASSEMBLY:

First, insert the three-wire sleeve through the wire hole in the motor mount and into the terminal compartment. Carefully slide the motor into the actuator body. Rotate the motor shaft, if necessary, to engage the pinion with the first combination gear. Install new motor assembly mounting screws (provided) and torque to recommended values (shown on page 6). Reconnect the motor wires per your actuator specific wiring diagram (under terminal compartment cover).

Inspect the barrier plate gasket and replace if necessary (see GASKETS in this section). To ensure a watertight seal between the plate and gasket, coat the gasket with a thin film of grease before replacing the terminal plate. Torque the screws to 3 lb-ft (4 N•m).

## MOTOR RESISTOR AND CAPACITOR NETWORK

There is no recommended replacement interval for the R-C components. Nonetheless, it may be advisable to replace these parts as a preventative measure when the motor is replaced on older actuators; this is why they are recommended spare parts.

The R-C values and part numbers for the motor assembly are shown in the "Gasket, Motor, Resistors & Capacitors" table on page 37. The resistor and capacitor are located in the wiring compartment below the terminal block.

To replace a resistor or capacitor, first remove the terminal cover, then follow the directions below.



### WARNING

**Electrical shock hazard. Disconnect power before proceeding.**

Remove the terminal block and barrier plate as an assembly to access the resistor and capacitor components. The capacitor(s) is fastened to the actuator body wall with a bracket and screws. The resistor assembly plate is also fastened to the body wall with screws. After removing the mounting screws (and bracket, if necessary), remove the existing part and transfer the wires one at a time from the existing part to the new replacement part (in some configurations, access to the screws may require removal of the DCM-3 compartment cover). Fasten the new parts in the same manner as the replaced parts.

Inspect the terminal plate gasket and replace if necessary (see GASKETS in this section). To ensure a watertight seal between the plate and gasket, coat the gasket with a thin film of grease before replacing the terminal plate. Torque the screws to 3 lb-ft (4 N•m).

# MAINTENANCE

## FUSE (F1) REPLACEMENT (FOR ACTUATORS EQUIPPED WITH OPTIONAL 208V OR HIGHER POWER SUPPLY)

If it is necessary to replace the power fuse (F1), use the following procedure:



**WARNING**  
Electrical shock hazard. Disconnect power before proceeding.

Remove the terminal block cover. Locate the fuse holder (similar to the illustration below).

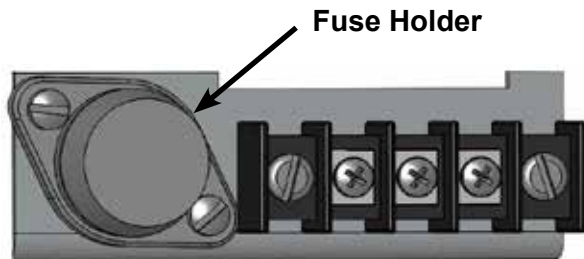

Turn the fuse holder CCW while pressing down. The fuse holder should spring loose when free. Remove the fuse holder from the actuator. Pull the fuse free from the holder. Replace the fuse with the same type (see table below) by pushing it into place.

Reinsert the fuse holder into the actuator. Turn the fuse holder CW while pressing down to tighten. Replace the terminal block cover. Tighten the cover screws to 6 lb-ft (8 N•m) torque.

### REPLACEMENT FUSES (F1)

Actuator	Input Voltage	Amps	Volts	Type	Part No.
11-489	208	3.2	250	Time Delay	11-1370-25
	240	3.2	250	Time Delay	11-1370-25
	480	1.4	600	Time Delay	11-1372-30

## LUBRICATION / GEARING

Periodic lubrication is not required on Beck actuators.

During planned maintenance shut-downs, however, it is recommended that older actuators be inspected to ensure that the gearing is not worn or damaged.

To inspect the gears, remove the gear module assembly. Clean the gears, removing as much old lubrication as possible.

Examine the gear teeth, shaft bore, and gear shafts for signs of excessive wear, scoring, or other damage. If there is no evidence of damage to the gearing, recoat the teeth and shaft bores of all gears with a heavy layer of Fiske Lubriplate GR-132 or equivalent (GR-132 is an extreme pressure grease with polymer additives). The ball bearing on the output shaft and crown gear shaft have double grease seals and require no maintenance for the life of the bearings. Inspect all other grease seals and replace any that show wear. Reassemble the actuator, referencing the table on page 6 for appropriate bolt torques.

If it should ever be necessary to replace the output shaft assembly, 3rd combination gear, or output shaft bearings, a major overhaul is required and the actuator must be returned to the factory for a repair evaluation.



**CAUTION**  
Before removing the gear module assembly from the actuator body, secure the output shaft, if necessary, to prevent movement.



**Gear Module**

## SELF LOCKING MECHANISM (SLM)

The Self Locking Mechanism (SLM) is assembled to the front of the motor and couples the motor to the gear train. The primary function of the SLM is to lock the gear train in place when the motor is de-energized. When the motor is energized, the SLM releases and allows the motor to drive the gearing.

There is no recommended maintenance interval for the SLM. The SLM can last for many years in normal service. SLM wear is a function of loading and the number of starts/stops the motor experiences over time. Overloading or stalling the actuator will accelerate SLM wear.

Signs of wear include the inability of the actuator to hold position when the motor is de-energized. This could result in persistent on-off oscillation. Severe SLM wear or damage may result in a loss of torque at the output shaft.

It is often possible to confirm SLM wear or damage by checking motor operation with the Handwheel. Place the Handswitch in the STOP position, and rotate the motor Handwheel back and forth. There should be free play before the motor pinion/gearing turns (up to one tenth of a full Handwheel rotation). Lack of free play or rough motor movement may indicate the need for SLM reconditioning.

Disassembly and close inspection of the SLM components is required to fully evaluate its condition.



### WARNING

**Electrical shock hazard. Disconnect power before proceeding.**

**Support the load before removing the motor/SLM from the actuator.**

### DISASSEMBLY AND CLEANING

When wear or damage is suspected, disassembly and cleaning may be required to determine the extent of needed repairs. Individual parts may be replaced, with the exception of the drive collar, which is not field replaceable. Refer to the table and illustration on the following page.

*For SLM disassembly and inspection:*

1. Disconnect power from the actuator.
2. Secure the actuator load, and remove the motor assembly (see page 29). Handle the motor with care so as not to damage the rotor shaft.

3. Pushing down firmly on the pinion, measure the gap between the stop collar and the thrust washer. This distance should measure  $0.025 \pm .005$ ". An excessive gap indicates worn SLM components.
4. Use a felt tip pen to mark the location of the castle nut on the shaft. Support the end of the rotor shaft to prevent it from bending, and drive the 1/8" spring pin out. Carefully (the spring assembly is spring-loaded) unthread the castle nut, remove the thrust washer/bearing, spacer, pinion, spring, and steel balls. Remove the (4) 1/4-20 screws and the front motor end (see the SLM Components illustration on the following page). DO NOT remove the front motor shield or the rotor from the stator on any model.



### CAUTION

**Do not disassemble the motor any further, as it has no other user serviceable parts. Further disassembly will result in demagnetization of the motor and loss of the required torque.**

5. Clean grease from the pinion and locking disc for inspection. A small amount of dust residue from the friction material is normal. Clean the drive collar detents with a rag and inspect for wear. Inspect the friction material for excessive wear or damage. If the friction material does not appear to be damaged, clean with alcohol to remove any contaminants.
6. Identify worn parts and replace as needed. Note, wear on the pinion teeth may indicate wear on the meshing gear. Further inspection of the gear module assembly is recommended. Drive collar detent wear will require factory repair of the motor.

*Continued*

# MAINTENANCE

## SLM (cont'd)

### REPLACEMENT AND REBUILD INSTRUCTIONS

1. If the friction material requires replacement, scrape off the old friction material and thoroughly clean the bonding surface to ensure flatness for the new friction material. Glue the new friction material in place with Loctite 454 Instant Adhesive or equivalent, taking care to keep the material flat and clean.
2. Apply a film of grease (Fiske Lubriplate GR-132 or equivalent) to the surface of the ball detents (16 places). Apply a *thin* film of grease to the inner diameter of the locking disc bore. Do not let the grease contact any friction surfaces. Excess grease can contaminate the friction surface and reduce SLM effectiveness.
3. With the motor shaft pointed up, place a steel ball into each of the drive collar detents. Install the locking disc and place a steel ball into each of the detents on the top of the locking disc.
4. Install the spring on top of the locking disc. Compress the spring by pushing down with the pinion. While holding the pinion in place, install the spacer, thrust bearing, and castle nut. Note: The grooved washers on each end of the thrust bearing have differently sized holes; the end with the washer having the smallest hole should be installed next to the castle nut. Thread the castle nut onto the shaft to hold the spring in compression.
5. Replace the front motor end O-ring (see figure below) and install the front motor end with the (4) 1/4-20 screws in a crisscross pattern, torquing to 6 lb-ft (8 N•m). Place RTV around the wire entry into the motor.
6. Pushing down firmly on the pinion, measure the gap between the castle nut and the thrust bearing. This distance should measure  $0.025 \pm .005$ ". This space is necessary to ensure proper operation. Tighten or loosen the castle nut as necessary to achieve the proper gap and simultaneously align one of the slots with the hole in the motor shaft. One complete slot rotation will change the gap by 0.009". Install the new 1/8" spring pin while supporting the shaft.
7. Recoat the gear teeth and components above the pinion liberally with a layer of Fiske Lubriplate GR-132 or equivalent.

### SLM REBUILD KIT MAJOR COMPONENTS (Descriptions & Part Numbers)

Motor Assembly	20-2201-34
Rebuild Kit (GL181-134)	12-8067-13
Spring	14-9980-26
Friction Material (GL181-134)	14-9409-52
Spring Pin	10-7111-05
Thrust Washer/Bearing	14-9400-02
Pinion	14-9940-69
Steel Ball	14-9420-03 (8)
Locking Disc	14-9330-19
Motor Gasket	20-0660-08
Instruction Sheet	80-0016-02
Terminal Joint	20-0032-01 (3)
Slip-on Terminal	20-0030-01
Spacer	20-2090-03
O-ring	14-9840-16
Motor Screw	30-0306-40 (4)

### SLM COMPONENT

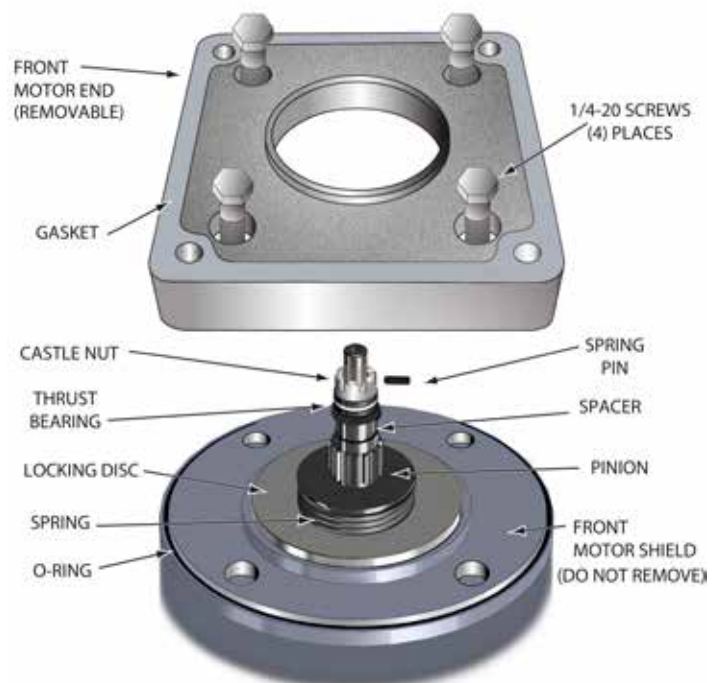

## OVER-TRAVEL LIMIT AND AUXILIARY SWITCHES

Complete switch assemblies may be replaced. It is not possible to replace individual switches. To replace switch assemblies, follow the instructions below.



### WARNING

**Electrical shock hazard. Disconnect power before proceeding.**

Remove the control end cover by loosening the four captive, socket head cap screws (1/2" wrench). Remove the screws holding the switch assembly to the switch plate and slide it out to the side.

Transfer the wires to the terminals of the replacement assembly, ensuring the correct wire is transferred to the correct replacement assembly terminal (wires have push-on lugs). Install the replacement assembly and note that it rotates around one screw to permit an adjustment of the cam-to-switch lever spacing and switch operating point. To set the switch, place a .030" (.75 mm) shim between the cam and switch lever (see photo to right). The switch lever should be on the low or minimum radius portion of the cam when setting the switches. Position the switch assembly so that the switch is just actuated. DO NOT overstress the switch lever. Tighten both screws to 10 lb-ft (14 N·m) torque and remove the shim.

## ADDING AUXILIARY SWITCHES

It is sometimes possible to add auxiliary switches in the field. If the actuator was built with two or less auxiliary switches, they may be added in multiples of two, for a total of up to four auxiliary switches. See the table at right for part numbers.

Install wiring onto the switch push-on lugs and route the wires into the actuator terminal area. Remove the terminal compartment cover and solder wires to the underside of the terminal board according to the wiring diagram included with the new switch assembly. Install the new switch assembly and adjust according to the preceding instructions.

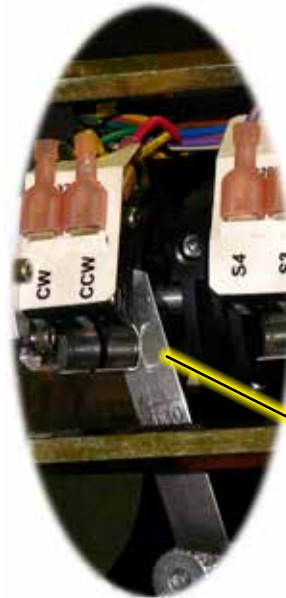

.030" (.75 mm) SHIM SHOULD BE INSERTED BETWEEN SWITCH ACTIVATION LEVERS AND THE CAMS WHEN SETTING SWITCHES.

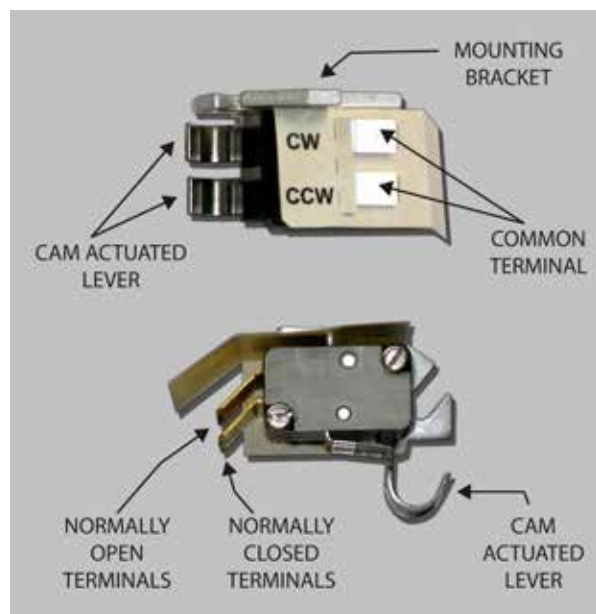

### SWITCH PARTS

Description	Part Number
Over-travel limit switch assembly (CW/CCW)	20-3202-10
Auxiliary limit switch assembly, (4) switches (S1/S2/S3/S4)	20-3202-12
Limit switch cam assembly	11-0931-02

# MAINTENANCE

## DCM-3 BOARD

Field repair of the DCM-3 board is not recommended.



### WARNING

Electrical shock hazard. Disconnect power before proceeding.

To replace the DCM-3 board, remove the Digital Control Module compartment cover (four captive, 5/16" hex head screws (1/2" hex wrench)). Loosen the four captive screws holding the board to its mounting pads. Note the "L" shaped mounting bracket on the end of the board. To remove the board, pull the mounting bracket away from its mating surface and connector receptacle.

To install a DCM-3 board, lightly press the board connector into its receptacle until the mounting bracket is flush with its mating surface. Tighten the four captive screws to 8 lb-in (0.9 N•m). Replace the DCM-3 compartment cover and tighten the cover screws to 10 lb-ft (14 N•m) of torque.

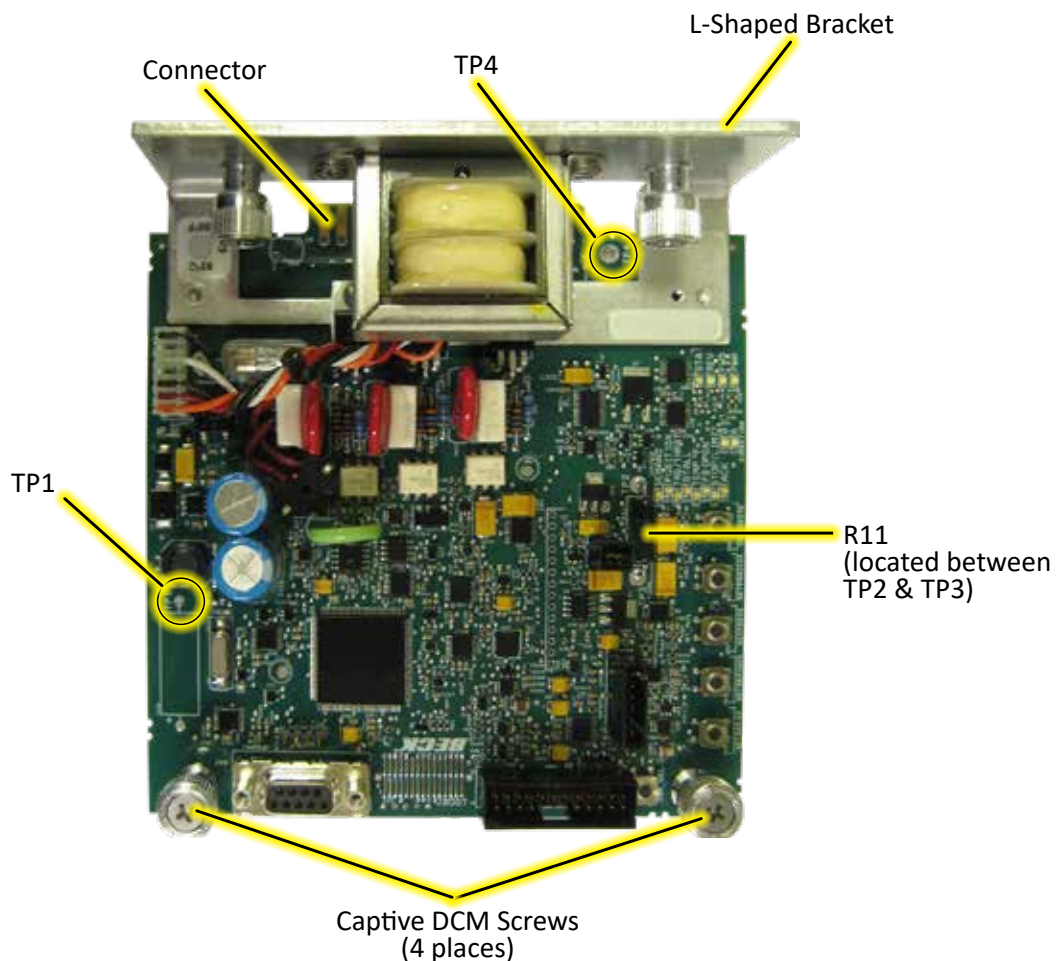

## CPS-5

Field repair of the CPS-5 is not recommended.



### WARNING

**Electrical shock hazard. Disconnect power before replacing the CPS-5.**

To replace the CPS-5, both the rotor and stator/circuit board assembly should be replaced. When returning the CPS-5 to the factory for service, do not separate the rotor and stator/circuit board assemblies from their mounting plates. The rotor should be held inside the stator with rubber bands when shipping.

The CPS-5 is configured to produce a position signal voltage between 1 and 5 volts over 100 degrees of travel; units configured for 90 degrees of travel will produce a position voltage between 1.2 and 4.8 volts. Configured properly, the CPS-5 raw position signal (measured at TP1 & TP4) increases as the output shaft rotates clockwise.

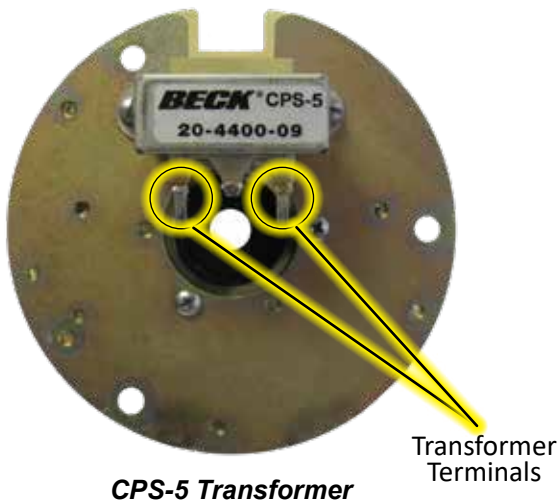

**CPS-5 Transformer**

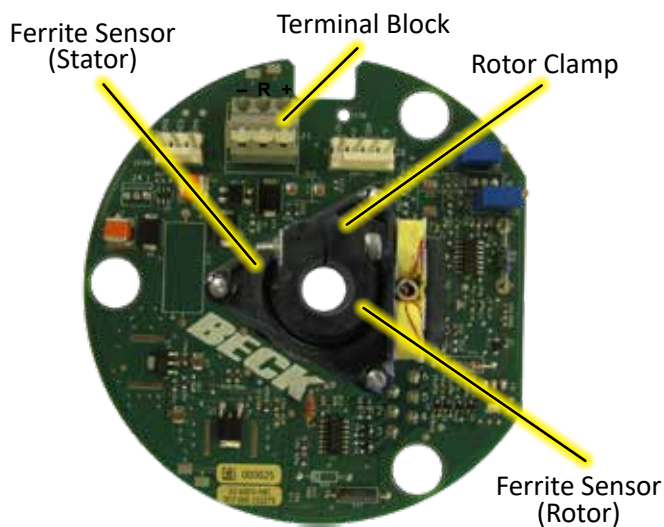

**CPS-5 Transducer Board**

### REMOVE THE EXISTING CPS-5 ASSEMBLY:

1. Run the actuator to its midpoint of travel with the local Handswitch.
2. Disconnect 120 Vac power to the drive. Remove the terminal, DCM-3 compartment and control end covers (1/2" wrench).
3. Record the wire colors on the terminal block of the CPS-5 (see illustration, this page), then disconnect the wires. The terminals are spring-loaded. To remove a wire, press the tip of a small screwdriver into the slot at the top of the small lever. Push down to open the spring-loaded contact and release the wire.
4. Pull the wires from the transformer (see illustration, this page) back through the wire hole in the CPS-5.
5. Loosen and remove the 3 hex studs that clamp the CPS-5 in place. Ensure that the inboard hex stud is not loosened as the outboard stud is loosened.
6. Slide the CPS-5 stator assembly off the three mounting bolts.
7. Note the position of the rotor clamp, then loosen the rotor clamp screw and remove the rotor from the shaft.

### INSTALL THE NEW CPS-5 ASSEMBLY:

8. Remove the rotor from the replacement CPS-5 assembly. Slide the rotor, clamp end first, onto the control shaft as close to the mounting plate as possible. Leave the clamp loose. Position the clamp in the same general location as the one removed previously.
9. Slide the new CPS-5 assembly over the studs and rotor. Replace the hex nuts but do not tighten. Carefully slide the rotor back into the CPS-5 assembly. Twist the rotor while sliding to prevent damage to the assembly. Tighten hex nuts to 5 lb-ft (7 N•m).
10. Thread the wires through the wire holes in the CPS-5 and reconnect them to the transformer and terminal block.
11. Restore 120 Vac power to the actuator and connect a meter to the output.
12. Insert a 0.031" (.80 mm) feeler gauge between the rotor clamp and stator. Position the clamp 0.031" (.80 mm) from the stator.
13. Rotate the rotor (only a minor adjustment should be necessary) on the control shaft until the output voltage measured across TP4 and TP1 (see illustration at right) reads 50% (approx. 3 volts) of the signal span. Tighten clamp to 5 lb-in (.6 N•m) torque.
14. Perform a position calibration procedure (p. 22).

# MAINTENANCE

## HANDSWITCH



### WARNING

Electrical shock hazard. Disconnect power before proceeding.

#### REMOVE THE EXISTING HANDSWITCH:

1. Remove power from the actuator.
2. Remove the terminal cover (1/2" wrench).
3. To access the Handswitch, the terminal barrier plate must be removed.
4. Clip the five wires from the old Handswitch (removing any tie wraps or sleeving that may interfere).
5. Remove the Handswitch knob by loosening the two inset screws (5/64" hex wrench).
6. Remove the threaded bushing behind the Handswitch knob. The remaining Handswitch assembly components may now be removed from the terminal compartment.

#### INSTALL THE NEW HANDSWITCH:

7. Insert the new threaded bushing through the actuator onto the shaft, then attach the components leading to the switch as shown in the illustration below.
8. Place the seal in the bushing, then insert the knob over the bushing. Tighten the two inset screws to 3 lb-ft (4 N•m).

9. Splice the wires from the new Handswitch assembly to the wires from the actuator, color to color. Ensure the wiring is not exposed after splicing.
10. Replace the terminal cover, tightening the captive screws to 10 lb-ft (14 N•m).

**NOTE: When the Handswitch is turned fully clockwise, "AUTO" should be indicated. Be sure to place the tab on the tabbed washer into the slot in the actuator body to secure the Handswitch in place.**

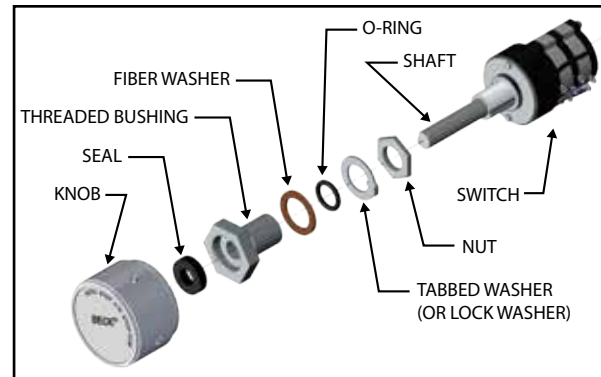

**HANDSWITCH COMPONENTS**

## GASKETS

During routine service, inspect removed cover gaskets for wear or damage. In order to protect internal components, worn or damaged gaskets and O-rings should be replaced.

To remove, scrape all of the old adhesive and gasket material from the body housing and cover, if necessary. Replacement gaskets are self-adhering, silicone rubber. Peel the backing off the replacement gasket and carefully apply to the actuator body.

## RECOMMENDED SPARE PARTS

The table below lists common recommended spare parts for the 11-489 actuator.

The Beck website ([www.haroldbeck.com](http://www.haroldbeck.com)) provides an actuator serial number lookup tool which will provide details specific to your actuator.

### COMMON RECOMMENDED SPARE PARTS

Description	Part Number
DCM-3 board	22-5020-59
Fuse, 7A, 125V (For use on DCM-3)	11-1372-26
CPS-5 assy.	20-4400-09
Gasket Kit	20-3110-03

Description	Part Number
Fuse (F1) w/ operating voltage >120 V	See page 30
Overtravel limit switch assy. (CW / CCW)	20-3202-10
Auxiliary switch assy. (4 switches (S1–S4))	20-3202-12
Motor, Capacitors, Resistor Assy.	See Below

### GASKET, MOTOR, RESISTORS, & CAPACITORS

Motor <sup>1</sup>					Capacitor		Resistor Assy.	
Part Number*	Current (Amps at 120 Vac, 60 Hz <sup>2</sup> )	Torque (N•m)	RPM	Freq. (Hz)	Part Number	Value (µf)	Part Number	Value (Ω)
20-2201-34	3.0	14.0	120	60	14-2840-15	25	20-1971-06	18
					14-2840-09	6		
				50	14-2840-15	25	20-1971-10	24
					14-2840-05	8		
				14-2840-09	6			

<sup>1</sup>The motor is rated 120 Vac regardless of operating voltages using optional transformers.

<sup>2</sup>50 Hz currents do not exceed 120% of 60 Hz levels.

\*Note that motor replacement part numbers will include the suffix "KIT"; e.g., 20-2201-34-KIT.

### TORQUE & SPEED BY GEAR MODULE ASSEMBLY and TRAVEL RANGE WITH MAX. STROKE TIMES

FULL TRAVEL (turns)	~ MAXIMUM STROKE TIME (mins.)	
	Gear Module P/N 14-9732-41**	Gear Module P/N 14-9732-42**
	90 lb-ft (122 N•m) 9.1 rpm* @ 60 Hz	120 lb-ft (122 N•m) 6.7 rpm* @ 60 Hz
5 to 9	1.0	1.3
7 to 14	1.5	2.1
14 to 25	2.7	3.7
25 to 45	4.9	6.7
35 to 70	7.7	10.4
65 to 125	13.8	18.8
115 to 225	24.9	33.9
200 to 405	44.8	60.9

\*50 Hz travel speed = 60 Hz x 1.2.

\*\*Note that gear module replacement part numbers will include the suffix "KIT"; e.g., 14-9732-41-KIT.

# TROUBLESHOOTING

The DCM-3 features diagnostics to help troubleshoot problems.

The following list provides a systematic method for isolating any actuator problems.

1. Operating Voltage
2. Handswitch Operation
3. DCM-3 Status Indication LEDs
4. DCM-3 Testpoints
5. DCM-3 Configuration
6. Inhibitors / Statistics

## VERIFY OPERATING VOLTAGE

To check the input power supply, view the Overview LEDs on the DCM-3 board (see photo on page 15). This requires removing the DCM compartment cover (see page 8 for location).

The PWR LED should pulse from dim to bright, which indicates that power is applied to the actuator and the DCM-3 is successfully completing (continuous) self-tests. If the PWR LED is not lit or pulsing, there may be a problem with the AC power supply to the actuator.

Ensure the actuator is receiving the proper operating voltage (listed on the actuator nameplate). To check the voltage, locate the power terminals on the terminal block (see wiring diagram on the underside of the terminal compartment cover). Using a voltmeter, measure the voltage applied to those terminals. If the voltage is correct, continue troubleshooting; if the voltage is not correct, apply the proper power.

## CHECK HANDSWITCH OPERATION

Verify proper operation of the Handswitch, which bypasses the actuator control electronics and switches power directly to the motor windings. Operate the actuator in both directions of travel using the Handswitch. If the actuator responds as expected, electro-mechanical problems with the motor and gearing may be eliminated. The trouble may lie with the electronics.

## CHECK DCM-3 STATUS INDICATION LEDs

The DCM-3 has seven Status Indication LEDs that provide specific information about the actuator's state (page 16). A lit LED indicates that a condition exists.

## CHECK DCM-3 TESTPOINTS

The DCM-3 controls actuator output position by comparing the actuator's Demand input signal with the internal Position feedback signal generated by the actuator's position sensor (CPS-5). The integrity of these signals is critical to actuator performance. The signals should be verified whenever there are actuator problems. There are four test points provided on the DCM-3 board (see illustration on page 15 for locations) that are used to measure the Demand input and internal Position signals directly at the DCM-3.

Measure the Demand signal voltage across TP2(+) and TP3(-) (see page 15 for location). A typical 4–20 mA input signal will measure a proportional 1–5 Vdc across the test points. It is important to verify that the measured voltage corresponds correctly to the signal that is being applied. If there is a mismatch, further troubleshooting is required.

The Position signal to the DCM-3 is generated by the actuator's CPS-5. The CPS-5 is designed to provide a 1–5 Vdc signal to the DCM-3 corresponding to the maximum travel (in turns) of the particular actuator.

## CPS-5 POSITION SIGNAL VOLTAGES

Shaft Position	Maximum Travel Turns	
	CW	CCW
0%	1.0	5.0
25%	2.0	4.0
50%	3.0	3.0
75%	4.0	2.0
100%	5.0	1.0

The Position signal can be determined at the DCM-3 by measuring the voltage across TP4(+) and TP1(-) (see page 15). Verify that this signal matches Demand and the position of the output shaft.

Both the Demand and Position signals can also be checked at the appropriate terminals in the terminal block, via HART communications or through the Serial port. All values should agree with test point values. Any differences will require further troubleshooting.

---

### **CHECK DCM-3 OPERATION MODE SETTING**

The DCM-3 can be configured for several operational modes as shown in HART menu 3E (page 47) or Serial command "opmode" (page 55).

The factory configuration is the "Follow" mode. In this mode, the actuator is positioned by the 4–20 mA Demand signal when the Handswitch is set to AUTO.

"Hold" mode causes positioning according to the HART Interface Demand Value (HART menu 3E).

"Stay" mode causes the output shaft to remain stationary and maintain its present position. In "Stay" mode, the Handwheel cannot be freely turned as it will move back to the position where the "Stay" mode was activated.

"Stop" mode removes power from the motor. In "Stop" mode the Handwheel can be freely turned. All operating modes can be overridden by the actuator Handswitch. If the operation mode is (inadvertently) switched to a mode other than "Follow" there will not be an outward indicator.

**Note that resetting the DCM-3 to factory settings does not change the operational mode back to "Follow" for safety purposes.**

### **CHECK DCM-3 INHIBITORS / STATISTICS**

Conditions that prevent the DCM-3 from positioning the actuator are called inhibitors. HART MENUS 5F and 5G list the CW and CCW inhibitors respectively. Inhibitors may also be reviewed by running the Serial command "stat" (see page 56). The following list indicates why the inhibitor would be in the "ON" state.

#### **Balance**

Demand and position are balanced.

#### **Supervisory**

DCM-3 is initializing.

#### **Stall**

A stall condition has been detected.

#### **OverTrq/Thr**

Not applicable to the 11-489.

#### **Switch Block**

Not applicable to the 11-489.

#### **Bad Pos Sig**

The position signal is out of range.

#### **Bad Dem Sig**

The Demand signal is out of range.

#### **Local Cal**

The calibrate button is being pressed on the pushbutton panel.

The factory can assist with troubleshooting—please provide the results of the above review to expedite assistance.

# TROUBLESHOOTING

CONDITIONS	POSSIBLE CAUSES	CORRECTIONS
1. No DCM-3 LEDs are illuminated.	<ul style="list-style-type: none"> <li>a. No power is applied to the actuator.</li> <li>b. Incorrect power is applied to the actuator.</li> <li>c. Main power fuse/breaker is blown.</li> <li>d. DCM-3 malfunction.</li> </ul>	<ul style="list-style-type: none"> <li>a. Apply operating voltage to the operating voltage terminals.</li> <li>b. Verify correct voltage on actuator nameplate and ensure that it is applied at the operating voltage terminals.</li> <li>c. Verify fuse/breaker integrity. Replace/reset if blown. Find cause of short circuit.</li> <li>d. Replace DCM-3.</li> </ul>
2. STAT LED is illuminated.	<ul style="list-style-type: none"> <li>a. A status alarm is active.</li> </ul>	<ul style="list-style-type: none"> <li>a. Check the status indication LEDs on the DCM-3. Continue troubleshooting based on the LEDs that are illuminated.</li> </ul>
3. Demand LED is illuminated.	<ul style="list-style-type: none"> <li>a. No Demand signal.</li> <li>b. Applied Demand signal is outside of configured range.</li> <li>c. Polarity of applied signal wires is reversed.</li> </ul>	<ul style="list-style-type: none"> <li>a. Apply a Demand signal to terminals AA (+) &amp; BB (-).</li> <li>b. Confirm Demand signal value via HART or by measuring DC voltage across DCM-3 test points TP3(+) &amp; TP2(-). Should be 1–5 volts for 4–20 mA applied signal.</li> <li>c. Correct the polarity of the applied control signal wires on terminals AA (+) &amp; BB (-).</li> </ul>
4. POSITION LED is illuminated.	<ul style="list-style-type: none"> <li>a. Position signal voltage generated by CPS-5 read by the DCM-3 is outside of the configured range.</li> <li>b. CPS-5 malfunction.</li> <li>c. DCM-3 malfunction.</li> </ul>	<ul style="list-style-type: none"> <li>a. Using the HART communicator check the Position Sensor Setup menu to verify the Present CPS voltage falls within the configured CPS Zero% and Span (typical range 1–5 volts); OR measure DC voltage between DCM-3 test points TP4 (+) and TP1 (-) to verify Present CPS voltage. If the voltage is outside of 1–5 volts, recalibrate or replace the CPS-5.</li> <li>b. Replace CPS-5.</li> <li>c. Replace DCM-3.</li> </ul>
5. STALL LED is illuminated.	<ul style="list-style-type: none"> <li>a. Actuator has stalled—unable to achieve desired position within the configured “STALL TIME”.</li> <li>b. The configured stall time is less than the configured Max Travel Time.</li> </ul>	<ul style="list-style-type: none"> <li>a. Eliminate the obstruction and reset the stall by reversing direction on your Demand signal, cycling the power, or issuing the stall reset from HART or Serial command.</li> <li>b. Configure the stall time to exceed the Max Travel Time via HART or Serial command.</li> </ul>
6. TEMP F LED is illuminated.	<ul style="list-style-type: none"> <li>a. The measured temperature at the DCM-3 is outside of the normal operating range of -40° to 185° F.</li> </ul>	<ul style="list-style-type: none"> <li>a. Protect the actuator from the extreme temperatures below or above the operating range to eliminate the alarm.</li> </ul>
7. FB OPEN LED is illuminated.	<ul style="list-style-type: none"> <li>a. The position Feedback circuit current loop is not complete.</li> <li>b. The position Feedback is enabled, but not in use.</li> </ul>	<ul style="list-style-type: none"> <li>a. Ensure the device measuring the 4–20 mA Feedback is properly terminated on terminals DD (-) and EE (+) and is applying a 0–800 ohm load resistance.</li> <li>b. Disable Feedback via HART or Serial command; OR terminate the Feedback loop by applying a 0–800 ohm load resistance across terminals DD and EE.</li> </ul>

CONDITIONS	POSSIBLE CAUSES	CORRECTIONS
8. STOP/LIMIT LED is illuminated.	<ul style="list-style-type: none"> <li>a. The applied power is below the tolerance (-15%) of the nameplate operating voltage.</li> <li>b. A DCM-3 fuse is open.</li> <li>c. A component failure has occurred on the DCM-3.</li> <li>d. The Handswitch is in STOP.</li> <li>e. The actuator has traveled to an over-travel limit switch.</li> <li>f. The actuator is not at an over-travel limit switch, but the limit switch is open.</li> </ul>	<ul style="list-style-type: none"> <li>a. Apply the correct operating voltage to the actuator per the voltage stamped on the nameplate.</li> <li>b. Replace the open fuse.</li> <li>c. Replace the DCM-3.</li> <li>d. Place the Handswitch in AUTO.</li> <li>e. Verify if the limit switch is set outside of the electrically calibrated limits. Readjust, if necessary, or replace.</li> <li>f. Replace the over-travel limit switch (CW/CCW) assembly.</li> </ul>
9. Power LED is pulsing bright to dim.	<ul style="list-style-type: none"> <li>a. This indicates normal function.</li> </ul>	<ul style="list-style-type: none"> <li>a. No action required.</li> </ul>
10. All LEDs are illuminated or flashing.	<ul style="list-style-type: none"> <li>a. A component failure has occurred on the DCM-3.</li> </ul>	<ul style="list-style-type: none"> <li>a. Replace the DCM-3.</li> </ul>
11. REV LED is illuminated, actuator is not moving, and there are no other status alarms.	<ul style="list-style-type: none"> <li>a. Operation mode is set to "STOP".</li> </ul>	<ul style="list-style-type: none"> <li>a. Using HART (operation mode menu) OR using Serial command "opmode", change operation mode to "Follow".</li> </ul>
12. Actuator will not hold position with Handswitch in STOP.	<ul style="list-style-type: none"> <li>a. Self Locking Mechanism (SLM) is worn or damaged.</li> </ul>	<ul style="list-style-type: none"> <li>a. Rebuild the SLM assembly.</li> </ul>
13. Motor runs, but the output shaft does not move in one or both directions.	<ul style="list-style-type: none"> <li>a. Self Locking Mechanism (SLM) has failed.</li> </ul>	<ul style="list-style-type: none"> <li>a. Rebuild the SLM assembly.</li> </ul>
14. PWR LED is flashing, no status LED's are lit and does not respond to Demand signal or Handswitch.	<ul style="list-style-type: none"> <li>a. The Handswitch is damaged.</li> <li>b. The Handswitch jumper between terminal A and C is missing or faulty.</li> </ul>	<ul style="list-style-type: none"> <li>a. Check continuity from terminals N to V and M to U with Handswitch in AUTO position. If either does not show continuity, replace Handswitch.</li> <li>b. Install a wire jumper between terminals A and C.</li> </ul>
15. PWR LED is flashing, no status LED's are lit, actuator functions with the Handswitch, but does not respond to Demand signal.	<ul style="list-style-type: none"> <li>a. A plug-in jumper has been installed in the 24-pin connector (J2) of the DCM-3 board.</li> </ul>	<ul style="list-style-type: none"> <li>a. Remove any jumpers from the J2 connector on the DCM-3.</li> </ul>
16. HART communications cannot be established with the DCM-3.	<ul style="list-style-type: none"> <li>a. The device description (DD) file is not installed.</li> <li>b. The HART communicator is not compatible with Beck equipment.</li> <li>c. The HART communications circuit on the DCM-3 is damaged.</li> </ul>	<ul style="list-style-type: none"> <li>a. Install the Beck MK-2 DD on your HART device.</li> <li>b. Utilize a compatible HART communicator or configure the actuator through the Serial port.</li> <li>c. Replace the DCM-3.</li> </ul>
17. Position voltage on DCM-3 testpoints TP4 and TP1 is within 1–5 volts DC following the actuator position, but the position Feedback signal at terminals DD and EE remains constant or is erratic.	<ul style="list-style-type: none"> <li>a. The position Feedback circuit on the DCM-3 is damaged.</li> </ul>	<ul style="list-style-type: none"> <li>a. Replace the DCM-3.</li> </ul>

# TROUBLESHOOTING

CONDITIONS	POSSIBLE CAUSES	CORRECTIONS
18. Output shaft rotates opposite of desired direction when applying a 4–20 mA Demand signal.	a. The rotation direction is incorrectly configured.	a. Configure the rotation direction using pushbutton, HART, or Serial method.
19. Motor erratic or runs in wrong direction in AUTO or using Handswitch.	a. Motor winding is open. b. Motor capacitor is shorted or open. c. Motor resistor is open.	a. Replace motor assembly. b. Replace capacitor. c. Replace resistor assembly.
20. Actuator does not follow input signal until maximum or minimum is reached, then drives uncontrollably to limit.	a. Wire jumpers on terminals M and N are reversed. b. CPS-5 is not calibrated.	a. Connect terminal jumpers from M to D and from N to F. b. Recalibrate the CPS-5.
21. Actuator oscillates in AUTO mode.	a. Excessive noise on the input signal. b. Physical obstruction causing a stall condition (e.g., valve jammed or load greatly exceeds actuator rating.) c. The DCM-3 is malfunctioning. d. Excessive wear in the gear train or bearings. e. CPS-5 Failure. f. Self Locking Mechanism (SLM) is worn or damaged.	a. Eliminate noise or increase actuator step size. b. Check operation with Handswitch and remove obstruction if present. Handswitch bypasses the DCM-3 board. c. Replace the DCM-3 board. d. Replace worn actuator parts. e. Replace the CPS-5 board. f. Rebuild the SLM.
22. Actuator will not run in either direction or one direction in AUTO or using Handswitch.	a. Over-travel limit switch failure. b. Handswitch failure.	a. Replace over-travel limit switch assembly (CW/CCW). b. Replace Handswitch assembly.
24. Actuator does not stop at normal or desired limit of shaft travel.	a. DCM-3 position calibrated incorrectly. b. Limit switches set incorrectly. c. Over-travel limit switch failure.	a. Calibrate DCM-3 0% and 100% positions. b. Readjust the limit switches. c. Replace the over-travel limit switch assembly (CW/CCW).
25. Position Feedback signal does not reach maximum signal, but low end calibration is correct.	a. Feedback loop is overloaded.	a. Make sure that the load resistance is between 0 and 800 ohms total across terminals DD and EE.
26. Actuator runs uncontrolled to one end of travel.	a. Handswitch Failure.  b. The DCM-3 is malfunctioning.  c. The CPS-5 is malfunctioning.  d. Terminal block jumpers F to N and D to M not connected. e. The actuator has detected a loss of Demand signal (LOS) and is configured for GTP 0% or 100%. f. Handswitch in CW or CCW position.	a. Check continuity from terminals A–V and A–U with Handswitch in AUTO and actuator power disconnected. If either shows continuity, replace Handswitch. b. Verify CPS-5 voltage signal at DCM-3 test points TP4 and TP1 for 1–5 volts DC corresponding with output shaft position. If signal is valid, replace DCM-3. c. Verify CPS-5 wire connections, check voltage at DCM-3 test points TP4 and TP1 for 1–5 volts DC corresponding with output shaft position. Replace CPS-5 if voltage does not change with position. d. Install jumpers. e. See troubleshooting condition no. 3 (Demand LED is illuminated). f. Return Handswitch to AUTO position.

# APPENDIX HART® Communication

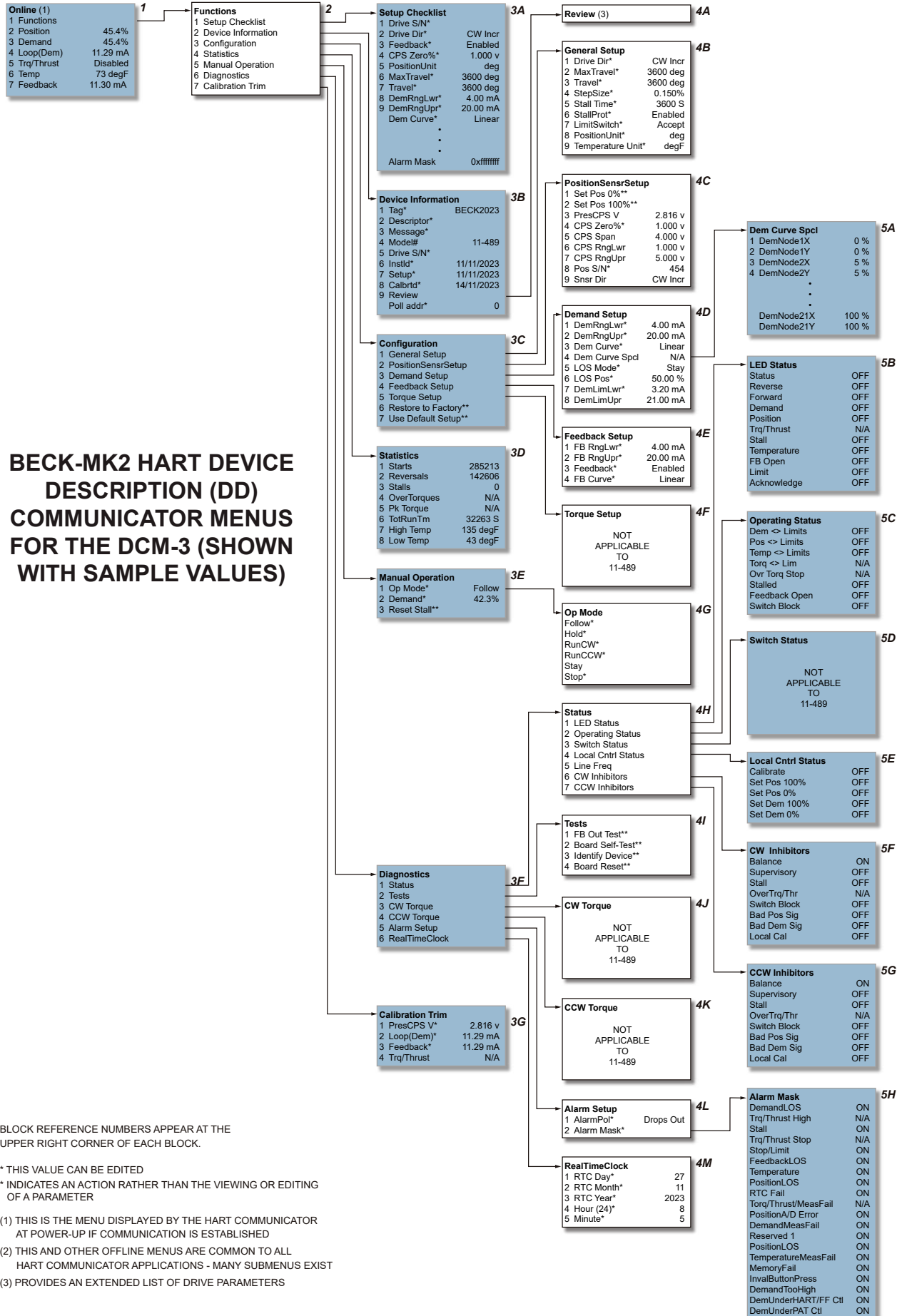

## BECK-MK2 HART DEVICE DESCRIPTION (DD) COMMUNICATOR MENUS FOR THE DCM-3 (SHOWN WITH SAMPLE VALUES)

BLOCK REFERENCE NUMBERS APPEAR AT THE UPPER RIGHT CORNER OF EACH BLOCK.

\* THIS VALUE CAN BE EDITED

\*\* INDICATES AN ACTION RATHER THAN THE VIEWING OR EDITING OF A PARAMETER

- (1) THIS IS THE MENU DISPLAYED BY THE HART COMMUNICATOR AT POWER-UP IF COMMUNICATION IS ESTABLISHED
- (2) THIS AND OTHER OFFLINE MENUS ARE COMMON TO ALL HART COMMUNICATOR APPLICATIONS - MANY SUBMENUS EXIST
- (3) PROVIDES AN EXTENDED LIST OF DRIVE PARAMETERS

# APPENDIX HART® Communication

The DCM-3 board is the control center of the actuator—configuration and calibration are accessed and set through the DCM-3 board. Using the HART interface requires a HART compatible communicator or any device, computer or controller capable of communicating with HART devices and supporting the Beck DCM-3 device description. This instruction supports actuators equipped with a DCM-3 (p/n 22-5014-59). This DCM-3 interfaces with the BECK-MK2 Device Description.

## HART® INTERFACE

The interface menu tree for communicating with a DCM-3 using the BECK-MK2 Device Description is located on the previous page. This menu tree summarizes possible setup options, features and available information.

## HART® COMMUNICATORS FOR BECK-MK2

The BECK-MK2 Device Description requires a HART Communicator that is HART 5 capable and has the ability to import Device Description Language Files (DDL) that are certified by the HART Communications Foundation.

## USING THE 275, 375 OR 475 HART® COMMUNICATOR

The HART Communicator leads should be connected in parallel with the analog Demand

signal wiring. This allows the communicator to simultaneously communicate over the analog input wires. This does not disturb the analog Demand signal, or disrupt the DCM-3 functions. However, any program changes to the DCM-3 will momentarily suspend the operation of the board (maintains last state) while the change is implemented. Typically, this is only for a second or two.

With the communicator connected in parallel anywhere across the analog Demand wires (see illustration below), it is ready to communicate. Turn on the communicator and wait for communications to be established. When communications are established, the “Online” display will appear. If the actuator is multidropped with other devices on a HART network, the first display screen will list all devices and require a selection before the “Online” display is shown. Follow the HART DD menu on the previous page to navigate.

**NOTE: If the communicator is unable to communicate with the DCM-3, it displays the message, “No Device Found”. If this occurs, check to make sure the leads are securely connected to the Demand wiring and retry. If communications still do not occur, the communicator polling setup may be improperly set. Check the “utility” menu and make sure communications polling is set to “always poll”.**

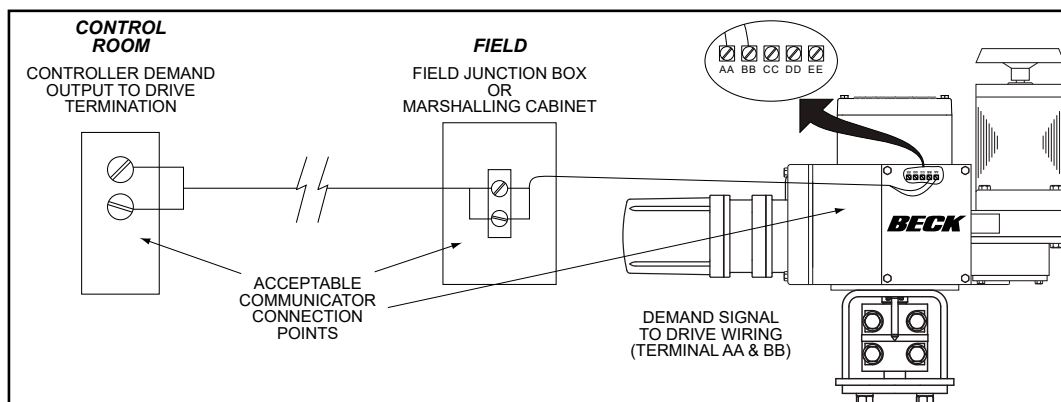

## MENU DESCRIPTIONS

(See HART Communicator Menu on page 43)

### MENU 1 -- Online

When communications are established with the communicator, the Online menu is displayed.

- 1 Functions:** The link to the menu tree.
- 2 Position:** The output shaft position displayed as a percent of range.

- 3 Demand:** The Demand signal displayed as a percent of range.
- 4 Loop (Dem):** The Demand signal measured in mA.
- 5 Trq/Thrust:** N/A.
- 6 Temp:** The ambient temperature of the DCM-3.
- 7 Feedback:** The milliamp output signal representing the present position of the output shaft.

## MENU 2 -- Functions

From the Functions menu, any of the DCM-3 functional menus can be selected and accessed. There are seven functional areas: Setup Checklist, Device Information, Configuration, Statistics, Manual Operation, Diagnostics, and Calibration Trim.

## MENU 3A -- Setup Checklist

The Setup Checklist provides a quick way for the user to setup the most important items necessary for basic actuator operation without having to move through multiple sub-menus. These items are defined on the following pages in their specific menu locations.

## MENU 3B -- Device Information

The Device Information menu provides information about the actuator. There are ten useful information entries that may be viewed and/or edited.

- 1 Tag:** An 8 character entry that can be used to identify a specific field device label.
- 2 Descriptor:** A 16 character field that can be used to provide any description desired.
- 3 Message:** A 32 character field that can be used to provide any message desired.
- 4 Model#:** Displays the model number of the actuator in which the DCM-3 is installed. This field may be edited. Note that changing this field may cause the "Use Default Setup" command to not function.
- 5 Drive S/N:** The Serial number as shown on the actuator nameplate.
- 6 InstId:** Installation date of the actuator or DCM-3.
- 7 Setup:** The setup date has no affect on actuator operation.
- 8 Calbrtd:** The calibration date has no affect on actuator operation.
- 9 Review:** Link to the Review menu.
- 10 Poll addr:** Used to find the actuator. Most configurations should use "0".

## MENU 3C -- Configuration

The Configuration menu serves as the gateway to all of the actuator operating parameters that can be used to configure the actuator based on the desired operation.

- 1 General Setup:** Link to General Setup menu.
- 2 PositionSensrSetup:** Link to PositionSensrSetup menu.

- 3 Demand Setup:** Link to Demand Setup menu.
- 4 Feedback Setup:** Link to Feedback Setup menu.
- 5 Torque Setup:** N/A.
- 6 Restore to Factory:** Restores field-configurable parameters back to the settings in effect when the DCM-3 was shipped from the factory.
- 7 Use Default Setup:** Changes the DCM-3 position sensing voltage ranges to the proper ranges for the actuator model.

## MENU 4B -- General Setup

This menu sets actuator operating parameters. The nine parameter entries are as follows:

- 1 Drive Dir:** The direction the output shaft rotates (looking into the output shaft) in response to an increasing Demand signal.
- 2 MaxTravel:** The maximum available travel distance of the output shaft in turns or degrees. This number corresponds to the actuator design—if the correct Serial Number is entered, this parameter should not be changed. The unit preference of turns or degrees may be set using the Serial command "travel".
- 3 Travel:** The number of turns or degrees of output shaft travel for 100% span. The unit preference of turns or degrees may be set using the Serial command "travel".
- 4 StepSize:** The smallest Demand change that will cause an output shaft movement.
- 5 Stall Time:** The amount of time the motor will run before Stall Protection is initiated.
- 6 StallProt:** This entry is set as either "Enabled" or "Disabled".
- 7 LimitSwitch:** This entry is set as either "Accept" or "Alert" and defines whether or not contacting an overtravel limit switch outside of the normal 0% to 100% travel range will cause an alarm condition.
- 8 PositionUnit:** The numeric unit of measure for the output shaft position in angular degrees.
- 9 Temperature Unit:** The unit of measure for temperature sensing. May be "degF" (fahrenheit) or "degC" (celsius).

# APPENDIX HART<sup>®</sup> Communication

## MENU 4C -- PositionSensrSetup

This menu contains parameters that determine how the DCM-3 interprets the output shaft position signal from the CPS-5.

- 1 Set Pos 0%:** Sets the 0% position to match the present output shaft position. This does not change the 100% position.
- 2 Set Pos 100% Span:** Sets the 100% position to match the present output shaft position. Also instructs the DCM-3 to change "Travel" span based on the 0% position. This does not change the 0% position.
- 3 PresCPS V:** Displays the CPS-5 signal voltage at the present output shaft position. Not editable.
- 4 CPS Zero%:** Displays the CPS-5 voltage at the 0% output shaft position. May be edited to define the voltage at the lowest operating point of travel.
- 5 CPS Span:** Displays the voltage signal span from the CPS-5 for maximum possible rotation of the output shaft. This is the upper range voltage minus the lower range voltage. Not editable.
- 6 CPS RngLwr:** Displays the CPS-5 voltage signal at the lowest possible point of travel. Not editable.
- 7 CPS RngUpr:** Displays the CPS-5 voltage signal at the highest possible point of travel. Not editable.
- 8 Pos S/N:** Displays the Serial number of the CPS-5 and has no effect on actuator function.
- 9 Snsr Dir:** The direction of output shaft rotation that causes the CPS-5 signal to increase. This direction is typically CW and is not editable.

## MENU 4D -- Demand Setup

The parameters on this menu determine the range and characterization of the Demand signal. It also includes parameters that determine behavior when the Demand signal is absent.

- 1 DemRngLwr:** Sets and displays the signal value in mA that represents 0% Demand (default is 4.00 mA, minimum is 0.5 mA). This value should be set above "DemLimLwr".
- 2 DemRngUpr:** Sets and displays the signal value in mA that represents 100% Demand (default is 20.00 mA, maximum is 21.00 mA). This value should be set below "DemLimUpr".

**3 Dem Curve:** Determines the relationship between the Demand signal and the position of the output shaft. Typically set to Linear, but may also be set to Square, Square Root or customized Special Curve.

**4 Dem Curve Spcl:** Link to the "Dem Curve Spcl" menu.

**5 LOS Mode:** Action on loss of Demand signal.

**6 LOS Pos:** If the "LOS Mode" has been set to "Go-to-Pos", this defines where the output shaft will move (in percent of travel) during loss of Demand signal conditions.

**7 DemLimLwr:** Sets the threshold (in mA) below which the Demand signal is considered lost. This value should be set below "DemRngLwr".

**8 DemLimUpr:** Sets the threshold (in mA) above which the Demand signal is considered invalid. The Demand alarm will activate until the signal is brought below this level. This value should be set above "DemRngUpr".

## MENU 5A -- Dem Curve Spcl

This menu allows setting the Demand signal characterization curve.

## MENU 4E -- Feedback Setup

This menu is where all the Feedback signal related actuator parameters are set.

**1 FBRngLwr:** The value of the Feedback signal (in mA) that corresponds to a 0% output shaft position. This value can range between 3.00 mA and 16.00 mA (default = 4.00 mA).

**2 FBRngUpr:** The value of the Feedback signal (in mA) that corresponds to a 100% output shaft position. This value can range between 7.00 mA and 21.00 mA (default = 20.00 mA).

**3 Feedback:** Enables or Disables the Feedback signal.

**4 FB Curve:** Allows a choice between a Feedback signal that linearly represents true shaft position or a characterized Feedback signal that inverts the effect of a characterized Demand signal.

**MENU 4F -- Torque Setup**

N/A

**MENU 3D -- Statistics**

This menu is where all the actuator's stored operating statistics are available.

- 1 Starts:** The total number of motor starts.
- 2 Reversals:** The total number of times the motor has started in the direction opposite to the previous start.
- 3 Stalls:** The total number of times the stall time has been exceeded.
- 4 OverTorques:** N/A.
- 5 Pk Torque:** N/A.
- 6 TotRunTm:** Total amount of time the motor has been powered (in seconds).
- 7 High Temp:** Highest temperature recorded in the DCM-3 compartment (in degrees fahrenheit).
- 8 Low Temp:** Lowest temperature recorded in the DCM-3 compartment (in degrees fahrenheit).

**MENU 3E -- Manual Operation**

This menu is used to allow manual operation using HART® communications. There are three manual operation procedures available:

- 1 Op mode (Menu 4G):** Selects the operating mode of the DCM-3. There are six possible choices: "Follow", "Hold", "RunCW", "RunCCW", "Stay" and "Stop". "Follow" mode is the normal state of operation and allows the DCM-3 control in response to the analog input Demand signal. "Hold" mode forces the DCM-3 to position according to the HART Demand value (see right). "RunCW" mode forces the actuator to move CW. "RunCCW" forces the actuator to move CCW. The "Stay" mode forces the actuator to maintain its present position. Note that in "Stay" mode, the Handwheel cannot be freely turned. The "Stop" mode removes power from the motor. Note that in "Stop" mode the Handwheel can be freely turned. Note that the Handswitch overrides all operating modes.
- 2 Demand:** This procedure sets the effective Demand signal. If "Op mode" is set to "Hold", entering a valid value (-5% to 105%) will control the motor. If "Op mode" is set to "Follow", the analog Demand signal is displayed (unless an alarm condition exists).

- 3 Reset Stall:** This procedure resets normal actuator operation after a stall condition has caused the motor to shut down. Note that stall conditions can also be reset by simply reversing the input Demand signal or cycling the actuator AC power.

**MENU 3F -- Diagnostics**

This menu provides access to all DCM-3 stored diagnostic information concerning actuator operation.

**MENU 4H -- Status**

This menu provides links to menus that monitor the operational status of the actuator. It also displays one parameter, line frequency.

- 5 Line Freq:** The power line frequency as measured by the DCM-3.

**MENU 5B -- LED Status**

The LED Status parameter allows remote checking of which LED's on the DCM-3 are illuminated.

**MENU 5C -- Operating Status**

The Operating Status parameter is a summary of whether process-related conditions are inside or outside of anticipated limits. These conditions control the Status Indication LEDs.

- 1 Demand:** Caused by the Demand signal falling below or above acceptable levels.
- 2 Position:** Caused by the CPS-5 signal being outside the range anticipated by the DCM-3.
- 3 Temperature:** The ambient temperature of the DCM-3 is outside of the rating.
- 4 Torque:** N/A.
- 5 Overtorque Stop:** N/A.
- 6 Stalled:** A Stall alarm is active.
- 7 Feedback Open:** The Feedback signal is enabled, but cannot follow the proper current.
- 8 Switch Block:** The DCM-3 cannot power the motor due to an electro-mechanical switch. Check the Handswitch and over-travel limit switches.

# APPENDIX HART<sup>®</sup> Communication

## MENU 5D -- Switch Status

Not applicable to Group 11 actuators.

## MENU 5E -- Local Cntrl Status

This parameter allows remote monitoring of which buttons on the local configuration interface are being pressed.

## MENU 5F -- CW Inhibitors

Allows viewing of the DCM-3 condition that is preventing the actuator motor from running in the CW direction.

## MENU 5G -- CCW Inhibitors

Allows viewing of the DCM-3 condition that is preventing the actuator motor from running in the CCW direction.

## MENU 4I -- Tests

This menu provides access to some routines that help determine if the actuator is functioning properly.

**1 FB Out Test:** Allows manual verification of the Feedback output signal to check operation and accuracy.

**2 Board Self-Test:** Instructs the DCM-3 to check various power and sensing circuits. This test will cause the actuator to reposition, so it should be run offline and only when a DCM-3 problem is suspected.

**3 Identify Device:** Causes the ACK LED on the DCM-3 to flash for two seconds. Ensures the HART system is addressing the correct actuator.

**4 Board Reset:** Causes the DCM-3 to initiate a reset cycle similar to a power-up reset. This manual reset will cause the actuator to reposition. This procedure is not typically necessary.

## MENU 4J -- CW Torque

N/A.

## MENU 4K -- CCW Torque

N/A.

## MENU 4L -- Alarm Setup

The Alarm Setup menu parameters allow modification of the behavior of the alarm.

**1 AlarmPol:** Whether the solid state relay opens on alarm or closes on alarm.

**2 Alarm Mask:** Link to the Alarm Mask menu which allows specific alarm conditions to be ignored.

## MENU 5H -- Alarm Mask

Allows selection of alarm conditions that will not cause an alarm at terminal E.

## MENU 4M -- RealTimeClock

This menu allows the date and time to be set.

**1 RTC Day:** Day of the month (numeric value).

**2 RTC Month:** Month (numeric value).

**3 RTC Year:** Year (4 digits).

**4 Hour (24):** Hour of the day (24 hour format).

**5 Minute:** Minute of the hour (0 through 59).

## MENU 3G -- Calibration Trim

The Calibration Trim menu sets and displays actuator calibration values. **Note that changing the calibration trim can cause signal measurement difficulties if performed improperly.**

**1 PresCPS V:** Displays and/or trims the present voltage of the position signal. This value may also be measured at DCM-3 test points TP1(-) and TP4(+). This trim is set and tested at the factory. Changing this value can cause voltage measurement errors.

**2 Loop(Dem):** Displays the Demand signal as measured at the field wiring terminals. When the Demand control loop signal is being overridden by a special mode of operation, the effective Demand will not correspond to the mA value. This value can be edited to trim the Demand to ensure accurate measurement of the analog signal. Demand can only be trimmed at 4.0 mA and 20.0 mA.

**3 Feedback:** Displays the mA signal representing the output shaft position as measured at the field wiring terminals. This value can be edited.

**4 Trq/Thrust:** N/A.

# APPENDIX HART® Messages

## COMMON HART® MESSAGES

HART® protocol maintains both standard and device specific informational messages that are displayed on the Communicator when various conditions occur.

Below is a table of typical Beck actuator messages and message sequences. It does not include all possible messages, only the most common.

### Output Shaft Position Measurement Messages

Message	Description
"Process applied to the primary variable is outside the operating limits of the field device."	This is a standard HART-defined message that appears whenever the HART primary variable (Position signal) is outside the design or calibrated range. This message should be accompanied by a Beck-specific message with more detail.
"The Position Signal is less than -5% or greater than 105%."	This Beck-specific message indicates the DCM-3 is reading a Position signal not within the calibration range limits.
"Position signal in LOS."	This is a Beck-specific message. The DCM-3 is indicating that the Position signal is a problem and is intended to identify a CPS-5 or wiring failure. This is triggered when the Position signal is outside the minimum and maximum voltage limits.
"Position out of accurate measurement range."	This is a Beck-specific message. The DCM-3 indicates the Position signal is outside of the design range.
"Position sensing error."	This is a Beck-specific message. The DCM-3 circuitry for measuring the Position signal does not appear to be functioning properly.
"Analog output 1 and its digital representation are outside the operating range limits, and not responding to input."	This is a standard HART-defined message that appears whenever the position signal to the DCM-3 is outside the design or calibrated range. This message should be accompanied by a Beck-specific message with more detail.

### Handswitch and Over-travel Limit Switch Message

Message	Description
"Motor power is blocked, check switches."	This message will appear if the DCM-3 detects a condition that prevents current flow to the motor.

### Stall Protection Message

Message	Description
"Stall condition has been detected (see 'Stall Time' in the 'General Setup' menu)."	This is a Beck-specific message indicating that the actuator is in a stalled condition. This occurs if the actuator cannot reach the Demand position in the time allotted by the stall time setting (configurable from 30–450 seconds).

## APPENDIX HART® Messages

### Demand, Torque and Temperature Measurement Messages

Message	Description
"Process applied to the non-primary variable is outside the operating limits of the field device."	This is a standard HART-defined message that appears whenever the Demand signal or Temperature are outside their design or calibrated ranges. This message should be accompanied by a Beck-specific message with more detail.
"The Demand Signal is outside of the intended limits (see Demand Setup menu)."	This Beck-specific message indicates the Demand signal is invalid.
"Demand out of accurate measurement range."	This is a Beck-specific message that the Demand signal is not only out of the calibrated range, but also out of the design range of the actuator. The lower and upper limits are 0.1 Vdc and 5.5 Vdc, respectively. Note that current input DCM-3 boards utilize a 250 Ohm input resistor to convert the current signal to voltage.
Demand Signal is out of limit.	This Beck-specific message indicates the Demand signal is too high to measure accurately. The upper limit is 5.5 Vdc. Note that current input DCM-3 boards utilize a 250 Ohm input resistor to convert the current signal to voltage.
Demand sensing error.	This is a Beck-specific message. The Demand sensing circuitry does not appear to be functioning properly.
The Torque/Thrust is greater than the output rating.	N/A.
Motor power has been removed due to excessive output torque.	N/A.
Torque/Thrust out of accurate measurement range.	N/A.
Torque/Thrust sensing error.	N/A.
The temperature is outside of -40°F to 185°F.	This is a Beck-specific message indicating that the temperature at the DCM-3 is outside of the acceptable range.
Temperature out of accurate measurement range.	This is a Beck-specific message. The DCM-3 ambient temperature reading is extreme and cannot be accurately measured.
Temperature A/D Fail.	This is a Beck-specific message. The DCM-3 circuitry for measuring the ambient temperature does not appear to be functioning properly.
The Feedback Signal is enabled but the loop is open.	This is a Beck-specific message indicating that the Feedback sourcing circuit is unable to create the proper signal current. This message could result from the signal not being wired to an external load, or a wiring failure has occurred at some point between the actuator and the monitoring device.

### Questionable Configuration Messages

Message	Description
Analog output 1 and its digital representation are in fixed mode, and not responsive to input changes.	Standard HART-defined message that appears whenever the Feedback signal has been manually assigned a value. This message should be accompanied by a Beck specific message with more detail.
Feedback is in fixed mode.	A Beck-specific message indicating that the Feedback signal has been manually set to a fixed value and is not following the Position value.
Local control button pressed while locked-out.	A Beck-specific message indicating an incorrect combination of pushbuttons is being pressed on the local configuration interface, or the local control interface is disabled and a pushbutton is being pressed.
Loop Current Detected while under HART/FF Control.	A Beck specific alarm message that alerts the user that analog current is present on the Demand terminals, but the DCM-3 is in an Op Mode expecting digital control. Make certain the Op Mode parameter is set properly.
Loop Current Detected while set for LOS PAT.	A Beck specific alarm message that alerts the user that analog current is present on the Demand terminals, but the DCM-3 is set to a LOS mode intended to be used without an analog signal.

### DCM-3 Failure Messages

Message	Description
Real-time Clock hardware failure.	This is a Beck-specific message. The data in the Real-time Clock appears invalid.
FRAM Memory has failed.	A Beck-specific message. The continuous built-in self-test cannot verify the memory for statistics information is operating properly.
Memory failure.	This is a Beck-specific message. The continuous built-in self-test cannot verify the microcomputer is operating properly.

### Miscellaneous HART-Defined Messages

Message	Description
Field device has more status available.	This is a standard HART-defined message that appears whenever the DCM-3 signals the HART master that an alarm or other undesirable status exists. This is the HART protocol mechanism for displaying the other messages in this section. If this message is displayed without an additional message, the status cleared before the HART master read the additional status.
A reset or self-test of the field device has occurred, or power has been removed and reapplied.	This message is presented by the HART master if the DCM-3 has gone through a power-up reset sequence since the last communication with the master. This message is only displayed once after a reset.
A modification has been made to the configuration of the field device.	This message indicates that the DCM-3 has undergone a configuration change since the last time the HART master has reset the change flag. Many HART masters disregard the flag and do not report this message.
Field device has malfunctioned due to a hardware error or failure.	This message indicates that the continuous built-in self-test cannot verify the microcomputer is operating properly.

# APPENDIX *Serial Communication*

## COMMUNICATIONS

Local configuration of the Beck actuator can be accomplished using Serial commands through the DCM-3 Serial port.



### CAUTION

**Changes made to the actuator through Serial communications may not necessarily be reflected in asset management systems. Be sure to verify any changes made serially and make manual corrections to the asset management system if necessary.**

The Beck Digital Control Module (DCM-3) is equipped with a Serial interface which allows for direct communication with a computer. Using a standard DB9 to USB cable, connect the DCM-3 to the computer using the DCM-3's DB9 connector (see below for location) and one of the computer's USB ports. Note: If your computer is equipped with an active COM port, a DB9 to DB9 cable may be utilized. See below for part numbers of cables available from Beck.

Once connected, communication can be established between the DCM-3 and the computer using a terminal emulation program, such as HyperTerminal®. This method of communication will allow for configuration, calibration and verification of actuator DCM-3 settings without the use of custom software applications.



DB9  
CONNECTOR

## HyperTerminal® SOFTWARE

HyperTerminal is the standard ASCII terminal emulation software provided with Microsoft® Windows®. If using HyperTerminal®, the following instructions will assist in setup. Note that some variation to these instructions may be necessary depending on the version of HyperTerminal® being used.

After connecting the DCM-3 to the (Windows®-based) computer, access HyperTerminal® by clicking first on "Start", then "Programs", then "Accessories", then "Communications", then "HyperTerminal". Double-click on the "Hypertrm.exe" icon to start the program. Once HyperTerminal® is running, it is necessary to set up a file with the proper settings to communicate with the DCM-3. Proceed as follows:

1. If prompted to install a modem, answer "no". Proceed to enter a name (e.g., "DCM-3") and select an icon (any will suffice) in the "Connection Description" box. Click the "OK" button.
2. The "Connect to" box should open next. At the bottom of the box, set the "Connect using" selection to the appropriate USB (or COM) port that has been connected to the DCM-3. Click the "OK" button.
3. The port properties box should open next; this is where the communication settings are established. The correct settings are:
  - a. Bits per second = "1200"
  - b. Data bits = "8"
  - c. Parity = "none"
  - d. Stop bits = "1"
  - e. Flow control = "none"
4. With the appropriate settings entered from Step 3, above, click "OK". Communications should now be enabled.
5. Press the "Enter" key twice. "OK" should be displayed indicating that HyperTerminal® is communicating with the DCM-3.

### Beck Serial Communications Cables



DB9 to USB-A  
P/N 20-0511-60



DB9 to DB9  
P/N 20-0511-14

\*Note cables may differ in appearance from depiction.

# **APPENDIX** *Serial Commands*

---

## **COMMANDS AND ARGUMENTS**

Commands can be used for a variety of functions including changing the operating configuration of the actuator, verifying operation settings, calibration and accessing diagnostic information. There are essentially four different types of commands:

1. Dual-purpose commands. These commands can be used to either modify actuator configuration settings or display the settings already set in the actuator. In order to set or make a change to the settings, the command requires an argument (*n*). If the command is used for display purposes only, the argument is omitted. Examples of these commands include "temperature" and "demlos".
2. Display only commands. These commands are used to display diagnostic or operating information such as present signal values. No arguments are required. Examples include the "stat" command and the "signals" command.
3. Set only commands. These commands serve only to make a parameter change. Typically, they apply to the actuator calibration. This type of command requires an argument, but unlike dual-purpose commands, they return an error message when entered without an argument. Examples include the "charset" and "trimfdbk4mA" command.
4. Execute action commands. These commands serve to reset, enable or disable features. Entering these commands produces an immediate action. Examples include the "reset" and "restoremodes" command.

The available commands are listed on the next several pages and each is described in detail. The command description explains the use or uses of the command, while the argument column describes any applicable arguments. Arguments are denoted as *n*. Note that the commands described as "sets and/or displays" signify dual-purpose commands that can be used with or without an argument for setting or verifying configuration settings.

# APPENDIX *Serial Commands*

## SERIAL COMMANDS

Below is a categorized list of Serial commands available through the DB9 interface. Details follow.

<b><u>Output Shaft Position Sensing Commands</u></b>	
cpsvat0pct travel travelmax	
<b><u>General Configuration Commands</u></b>	
alarmout alarmoutmask configformodel drvdir limitalarm opmode restoremodes sernum stallprot stalltime stepsize	
<b><u>Diagnostic and Information Commands</u></b>	
demsources help ledtest reset signals stat temperature un stall	
<b><u>Demand Signal Commands</u></b>	
dem0pctma dem100pctma demlos demlogstp demlogstp delay trimdem4ma trimdem20ma	
<b><u>Demand Characterizer Commands</u></b>	
charclear charlist charset demfunc	
<b><u>Feedback Signal Commands</u></b>	
fdbk0pctma fdbk100pctma fdbkfunc trimfdbk4ma trimfdbk20ma iomode	

### Output Shaft Position Sensing Commands

Command	Description	Argument <i>n</i> and Information
cpsvat0pct <i>n</i>	Sets/displays the DCM-3 voltage setting used to determine 0% signal from the CPS-5. Voltage is dependent upon the actuator model. Typically, this setting does not need to be changed.	<i>n</i> = desired voltage as a decimal (carried out to 3 decimal places). The standard signal range for an actuator configured for 100 degrees of output shaft rotation is approx. 1.000–5.000 V.
travel <i>n1, n2</i>	Sets/displays the number of turns or degrees that represents 100% travel. This command does not shift the 0% position; when increasing travel from a reduced travel setting, the 0% position may need to be changed first to keep travel within acceptable end points. The end points are defined by the CPS-5 voltage range.	<i>n1</i> = desired length of travel in turns or degrees. This value cannot exceed the maximum output shaft rotation of the actuator. <i>n2</i> = "0": degrees or = "3": turns
travelmax <i>n1, n2</i>	Sets/displays the number of degrees/turns that represent the maximum travel.	<i>n1</i> = maximum output shaft travel in degrees or turns <i>n2</i> = "0": degrees or = "3": turns

## General Configuration Commands

Command	Description	Argument <i>n</i> and Information
alarmout <i>n</i>	Sets/displays the polarity of the alarm output solid state relay.	<i>n</i> = "0": open on Alarm <i>n</i> = "1": closed on Alarm Upon loss of power, the relay is open regardless of the setting.
alarmoutmask <i>n</i>	Sets/displays (in hexadecimal format) which conditions will cause an alarm: 0x00000001 - Demand Loss of Signal 0x00000004 - Stall Condition 0x00000010 - Stop/Limit 0x00000020 - Feedback Loss of Signal 0x00000040 - Temperature too High/Low 0x00000080 - Position Outside of Limits 0x00000100 - Real-time Clock Failure 0x00000400 - Position Analog/Digital Circuit Failure 0x00000800 - Demand Measurement Failure 0x00002000 - Position Loss of Signal 0x00004000 - Temperature Measurement Failure 0x00008000 - Memory Failure 0x00010000 - Invalid Button Pressed 0x00020000 - Demand too High	<i>n</i> = "0x0": no listed condition causes a status alarm <i>n</i> = "0xffffffff": all listed conditions cause a status alarm <i>n</i> = hexadecimal value for specific condition(s) which will cause an alarm. Multiple conditions may be selected by performing a hexadecimal addition of the condition values; e.g., Demand Loss of Signal and Demand Measurement Failure -- <i>hex</i> 0x01 + 0x0800 = 0x801.
configformodel <i>n</i>	Sets certain DCM-3 default values based on the actuator Serial number. These values are direction rotation for an increasing CPS-5 signal, expected range of CPS-5 signal, and the maximum travel.	<i>n</i> = "1": executes command
drvdir <i>n</i>	Sets/displays the actuator output shaft rotation direction resulting from an increasing Demand signal.	<i>n</i> = "0": CW rotation <i>n</i> = "1": CCW rotation
limitalarm <i>n</i>	Sets/displays alarm action if the actuator travels outside of the electronic limits and contacts an over-travel limit switch.	<i>n</i> = "0": mute (no alarm) <i>n</i> = "1": always
opmode <i>n</i>	Sets/displays the mode that controls the Demand signal source. This mode selects analog or digital control.	<i>n</i> = "0": analog Demand <i>n</i> = "1": digital Demand <i>n</i> = "2": run CW <i>n</i> = "3": run CCW <i>n</i> = "4": stay <i>n</i> = "5": stop
restoremodes <i>n</i>	Returns the DCM-3 settings to the original factory configuration.	<i>n</i> = "1": executes command
sernum <i>n</i>	Sets the actuator Serial number.	<i>n</i> = Serial number
stallprot <i>n</i>	Sets/displays stall protection state.	<i>n</i> = "0": disabled <i>n</i> = "1": enabled
stalltime <i>n</i>	Sets/displays time the actuator runs in one direction before stall alarm is activated.	<i>n</i> = seconds: acceptable range is 30–3600 seconds.
stepsize <i>n</i> %	Sets/displays the size of one incremental movement of the output shaft.	<i>n</i> = % of travel desired: acceptable range is 0.10%–2.5%. Include the "%" symbol after the number or the unit of measure will be degrees.

## APPENDIX Serial Commands

### Diagnostic and Information Commands

Command	Description	Argument <i>n</i> and Information
demsources	Provides a readout of information regarding the Demand on the actuator including the source of the Demand signal (Handswitch, demlos or Analog I/P), mode (follow, hold, CW, CCW, Stay or Stop), currently applied Demand signal as a %, the Demand function (linear, square root, square, or special), and the Demand out as a % (dem out shows the signal adjusted when using a non-linear Demand function (demfunc command)).	No Argument
help <i>n</i>	Displays help text for a specific command or lists all available Serial commands.	<i>n</i> = command name <i>n</i> = "all"
ledtest <i>n</i>	Tests the functionality of the DCM-3 LEDs individually or as a group. If "all" is selected, the command will consecutively cycle through each LED twice. If an individual LED is selected, it will flash 12 times.	<i>n</i> = "1": DEMAND <i>n</i> = "2": POSITION <i>n</i> = "3": TRQ/THRUST <i>n</i> = "4": STALL <i>n</i> = "5": TEMP °F <i>n</i> = "6": FB OPEN <i>n</i> = "7": STOP/LIMIT <i>n</i> = "8": ACKNOWLEDGE <i>n</i> = "100": FWD <i>n</i> = "101": REV <i>n</i> = "102": STAT <i>n</i> = "All"
reset <i>n</i>	Performs the same reset sequence as when power is removed and reapplied.	<i>n</i> = "1": must equal "1" for command to execute.
signals	Displays the present DCM-3 readings of four signals: Position signal from CPS-5, Demand, Feedback, Torque	No argument = signal readings are displayed. <i>n</i> = "all": an extended set of data is displayed.
stat	Displays information on the status of the actuator, including: Time / Date, Demand, Position, Error (Demand minus Position), Step size, Dead band, Motor Status, Motor Run Time, Line Frequency, Motor Starts, Motor Reversals/Stalls, CW and CCW Inhibitor Status, Alarms	No argument
temperature <i>n</i>	Displays three values describing the ambient temperature in the actuator. Low extreme, present, high extreme. Can also change the temperature units.	No argument = temperatures are displayed. <i>n</i> = "F": changes units to Fahrenheit <i>n</i> = "C": changes units to Celsius
uninstall	Resets the Stall Protection alarm to restore power to the motor. If the motor is still physically stalled, the Stall Protection alarm will recur.	No argument.

## Demand Signal Commands

Command	Description	Argument <i>n</i> and Information
dem0pctma <i>n</i>	Sets/displays the Demand signal value that corresponds to 0% actuator position.	<i>n</i> = Demand signal as a decimal in mA. Minimum value is 0.50; maximum value is 100% Demand less 4.00 mA (e.g., if 100% Demand is 20.00 mA, the 0% value must be set for 16.00 mA or less).
dem100pctma <i>n</i>	Sets/displays the Demand signal value that corresponds to 100% actuator position.	<i>n</i> = Demand signal as a decimal in mA. Minimum value is 0% Demand plus 4.00 mA (e.g., if 0% Demand is 4.00 mA, the 100% value must be set for 8.00 mA or greater). Maximum value is 21.00 mA.
demlos <i>n</i>	Sets/displays the Demand signal threshold, below which the DCM-3 recognizes the signal has been lost. The threshold is entered as a value in mA. This command also sets/displays the action initiated by the actuator during LOS (Loss Of Signal). LOS action options are "sip" (stay in place) or "gtp" (go to position). Demlos always reports both settings, but only sets one argument at a time. Demlos must be used twice to set both the threshold and action.	<i>n</i> = Demand signal in mA below which LOS occurs (e.g., the typical value for a 4–20 mA system is 3.20). <b>-OR-</b> <i>n</i> = "sip", "gtp" or "pat". The "pat" argument acts the same as "sip", but also suppresses the alarm--this is used in some pulsed applications.
demlosgtp <i>n</i>	Sets/displays the position to which the actuator will run upon loss of the Demand signal (LOS). This command has no effect if the actuator is set to "sip" (stay in place).	<i>n</i> = desired position of actuator expressed as a percentage of actuator travel in decimal form (e.g., 50% = 50.00).
demlosgtp delay <i>n</i>	Sets the time delay in seconds before the actuator will move to the position set in "demlosgtp". Entering this command without an argument will return the present gtp and delay settings.	<i>n</i> = time delay in seconds. Acceptable values are 0 (default) to 25.5.
trimdem4ma 4	Trims the Demand analog-to-digital sensing circuit to be accurate at 4 mA. This command should only be used when the Demand signal at the actuator is exactly 4.0 mA. Trim is factory set and should not normally require recalibration.	"4" is the only acceptable value; this trim can only be performed at 4 mA.
trimdem20ma 20	Trims the Demand analog-to-digital sensing circuit to be accurate at 20 mA. This command should only be used when the Demand signal at the actuator is exactly 20.0 mA. Trim is factory set and should not normally require recalibration.	"20" is the only acceptable value; this trim can only be performed at 20 mA.

## **APPENDIX** *Serial Commands*

### **Demand Characterizer Commands**

<b>charclear <i>n</i></b>	Clears a preconfigured Demand characterizer curve node by setting it to "unused". Any node numerically higher will be set to "unused" also.	<b><i>n</i></b> = node: between 1 and 21.
<b>charlist <i>n</i></b>	Displays the X-values and Y-values of Demand characterizer curve node(s).	<b><i>n</i></b> = node: between 1 and 21. <b><i>n</i></b> = "all": displays all nodes
<b>charset <i>n1, n2, n3</i></b>	Sets the X-values and Y-values of a specific node of the characterizer curve. The three arguments must be separated by commas.	<b><i>n1</i></b> = node number to modify <b><i>n2</i></b> = X-value as a % <b><i>n3</i></b> = Y-value as a %
<b>demfunc <i>n</i></b>	Sets/displays the Demand signal characterization function.	<b><i>n</i></b> = "0": linear <b><i>n</i></b> = "1": square root <b><i>n</i></b> = "4": special curve <b><i>n</i></b> = "5": square

## Feedback Signal Commands

<b>fdbk0pctma <i>n</i></b>	Sets/displays the mA value of the Feedback signal that represents the 0% output shaft position. May also be set for decreasing direction of Feedback. See page 26.	<b><i>n</i></b> = desired Feedback signal in mA at 0% output shaft position. Minimum value is 3.00 mA and the maximum must be at least 4.00 mA less than the Feedback signal value for the 100% output shaft position.
<b>fdbk100pctma <i>n</i></b>	Sets/displays the mA value of the Feedback signal that represents the 100% output shaft position. May also be set for decreasing direction of Feedback. See page 26.	<b><i>n</i></b> = desired Feedback signal in mA at 100% output shaft position. Minimum value must be at least 4.00 mA greater than the Feedback signal value for the 0% output shaft position. Maximum value is 21.00 mA.
<b>fdbkfunc <i>n</i></b>	Sets/displays the curve used to calculate the Feedback signal.	<b><i>n</i></b> = "0": linear <b><i>n</i></b> = "1": inverse Demand (curve enabled)
<b>trimfdbk4mA <i>n</i></b>	Trims the Feedback signal at 4 mA. Calibrated at the factory, should not normally require calibration.	<b><i>n</i></b> = present Feedback signal from the DCM-3 in mA.
<b>trimfdbk20mA <i>n</i></b>	Trims the Feedback signal at 20 mA. Calibrated at the factory, should not normally require calibration.	<b><i>n</i></b> = present Feedback signal from the DCM-3 in mA.
<b>iomode <i>n</i></b>	Sets/displays the function of a DCM-3 connector pin. May be enabled for Feedback or potentiometer.	<b><i>n</i></b> = "0": none <b><i>n</i></b> = "1": Feedback enabled <b><i>n</i></b> = "2": potentiometer enabled.

## **APPENDIX** *Optional DCM-3 w/ Feedback Display*

The DCM-3 Feedback display is an illuminated, numerical readout showing the actuator's position as a percentage of full travel. This display is viewed through a tempered glass window in the electronics compartment. There are also two configurable LEDs visible—a red LED and a green LED.

The DCM-3 display has been calibrated at the factory and should not require any further adjustments.

The display is dependant on the Feedback loop current and will not operate until the loop is closed. If not utilizing external Feedback, a jumper must be installed between terminals DD and EE on the terminal block to activate the display. The Feedback output maximum loop resistance is 500Ω.

The configuration for the Feedback display is 4 mA = 00.0(%) and 20 mA = 100.0(%). By default, the green LED will light when the Feedback is indicated at less than 1(%). The red LED will light when the Feedback is indicated at greater than 99(%).

The illumination points for the LEDs may be modified using a serial command (see next page).

For information on serial communication and commands, see page 52.

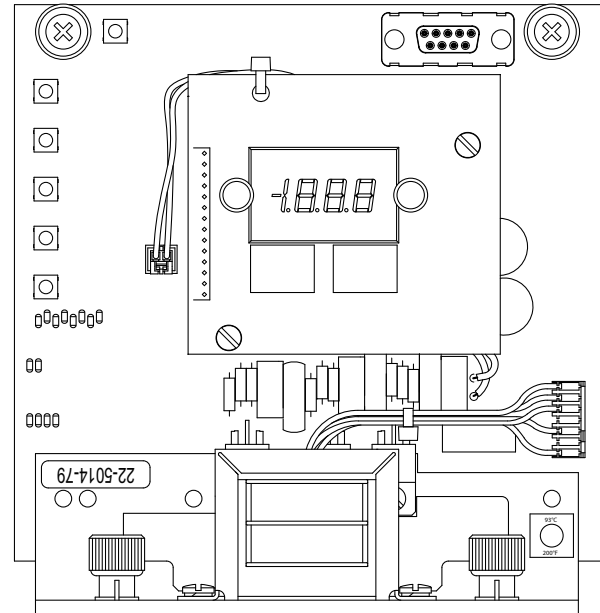

***DCM-3 with Feedback Display  
Part No. 22-5014-79***



Command	Description	Argument <i>n</i> and Information
<code>ledconfig n1 n2</code>	Changes the point within the position of travel that causes the LEDs to light. May also be used to swap the LED end point assignments (see Example 2, below) or to individually turn off each LED.	<p><b>n1</b> = "red": sets the red LED to the <b>n2</b> argument.  "green": sets the green LED to the <b>n2</b> argument.  "inverted": swaps the LED end point assignments (see Example 2, below).  "noninverted": sets both LED end points to the default setting (see below).</p> <p><b>n2</b> = argument defining position of travel at which the selected LED (<b>n1</b>) will light. Accepts any number representing a valid percentage of travel position.  "off": turns off the LED defined in <b>n1</b>.</p>

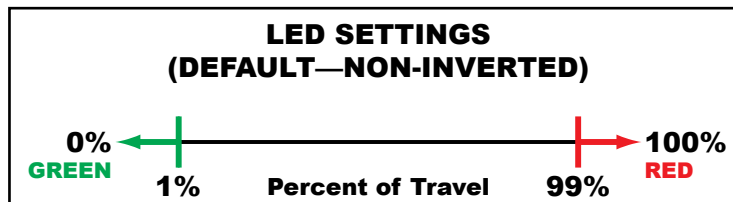

*Example 1: Make the "CLOSED" green LED light at 2.0% and the "OPEN" red LED light at 98.0%.*

COMMAND	RESULTING LED BEHAVIOR
<code>ledconfig green 2</code> <code>ledconfig red 98</code>	<p style="text-align: center;">0% GREEN ← 2%      Percent of Travel      98%      → 100% RED</p>

*Example 2: Invert the LED assignments from the default configuration.*

COMMAND	RESULTING LED BEHAVIOR
<code>ledconfig inverted</code>	<p style="text-align: center;">0% RED ← 1%      Percent of Travel      99%      → 100% GREEN</p>

*Example 3: Make the "OPEN" red LED light at 1.0% and greater, and the "CLOSED" green LED light at less than 1.0%.*

COMMAND	RESULTING LED BEHAVIOR
<code>ledconfig green 1</code> <code>ledconfig red 1</code>	<p style="text-align: center;">0% GREEN ← 1%      Percent of Travel      99%      → 100% RED</p>

**NOTE:** Both LEDs will not light at the same time; in the event of overlap, the red LED will light.

# INDEX

Appendices .....	43–61	Lubrication/Gearing .....	30
HART® Communication .....	43–48	Motor Assembly .....	29
HART® Messages .....	49–51	Motor Capacitor & Resistor Network .....	29, 37
Serial Communication .....	52	Motor/Gear Mod. Assy.'s, Torque/Timing .....	37
Serial Commands .....	53–59	Over-travel Limit & Auxiliary Switches .....	33
Optional DCM-3 w/ Feedback Display... ..	60–61	SLM .....	31–32
Application Reviews .....	63	Optional DCM-3 w/ Feedback Display.....	60–61
Auxiliary Limit Switches .....	18	Outline Dimension Drawings .....	6
Setting Switches .....	18	Position Feedback Signal .....	25–26
Configuration/Calibration .....	17–28	Power Quality .....	10
Contactless Position Sensor (CPS-5).....	13, 35	Precautionary Information .....	8
Demand Calibration .....	23	Product Demonstrations .....	63
Digital Control Module (DCM-3) .....	13–16	Restore Factory Settings .....	20
Interfaces .....	14	Safety Precautions .....	8
Overview LEDs.....	15	Self-Locking Mechanism (SLM).....	31–32
Pushbutton Controls .....	16	Serial Commands .....	53–59
Status Indication LEDs .....	16	Serial Communication .....	52
Direction of Output Shaft Rotation.....	19	Services .....	63
Electronics .....	13–16	Site Surveys .....	63
Fuse (F1), 3-Phase Power .....	30	Spare Parts, Recommended .....	37
General Specifications.....	4–5	Specification Writing .....	63
Handswitch .....	9, 36	Stall Protection .....	28
Handwheel.....	9	Start-up.....	12
HART® Communication .....	43–48	Step Size .....	20
HART® Device Description Menu .....	43	Storage Information .....	8
HART® Messages .....	49–51	Table of Contents.....	3
How to Obtain Service.....	63	Temperature Sensing .....	27
Installation .....	9–12	Travel (Turns/Degrees Rotation) .....	21
Electrical .....	10	Change Travel .....	22
Mechanical .....	9	Troubleshooting .....	40–42
Wiring .....	11–12	Warranty Statement.....	63
Introduction.....	2		
Limit Switches (Over-travel) .....	17		
Setting Switches .....	17		
Loss of Demand Signal (LOS).....	24		
Maintenance .....	29–37		
CPS-5 .....	35		
DCM-3 Board.....	34		
Fuse (F1), 3-Phase Power .....	30		
Gaskets .....	36		
Handswitch .....	36		

# SERVICES

## PRODUCT DEMONSTRATIONS

Each of Beck's Sales Engineers has access to a complete set of actuator models so that he can demonstrate virtually any of their features at your location. In order to arrange to see a Beck actuator in your plant or office, contact Beck's Sales Department.

## SITE SURVEYS

Beck Sales Engineers are available to discuss your process control requirements. Often a visit to your location is the best way to gain a thorough understanding of your needs, in order to meet them most accurately and completely.

Mounting hardware, torque requirements, linkage, control signal information, and optional equipment can be analyzed most effectively at the work site. Beck's analysis at the job site can help ensure that specifications are accurate, especially in the case of complex applications.

## APPLICATION REVIEWS

By sharing your needs with a Beck Sales Engineer you can take advantage of the best application advice for the type of control you need.

This review will yield a better understanding of the versatility of Beck actuators for your installations, as well as complete details on options and accessories to make the process as effective as possible.

## SPECIFICATION WRITING

Beck provides specification writing assistance in order to help you specify and order the right actuators for your applications. Beck Sales Engineers will work with you to make it easier for you to obtain the proper equipment and give you confidence that no details are overlooked.

## HOW TO OBTAIN SERVICE

Factory repair of actuators or subassemblies is available for both normal and emergency service. To assure prompt processing, contact the factory to receive a Returned Material Authorization (RMA) number. If a repair estimation is desired, please send the name and phone number of your contact for service authorization. It is helpful to include a description of the work desired with the shipment or, in the event of a problem, the malfunction being experienced.

## THREE YEAR LIMITED EQUIPMENT WARRANTY

Beck warrants to Buyer that: (i) for a period of 3 years from the date of shipment, the Equipment manufactured by Beck shall materially conform to Beck's published standard specifications in effect as of the date of shipment; and (ii) the Beck Equipment will be free from defects in materials and workmanship. This warranty does not apply to normal wear and tear, or where Beck Equipment failure is a result of improper installation, improper storage, misuse or improper maintenance, or water ingress related to Buyer or its agents failing to apply the stated torque requirements to fasteners when attaching covers or failing to replace temporary conduit plugs as stated in the installation instructions, or entry through conduits.

During the Limited Warranty Period, Buyer shall notify Beck of any alleged warranty claim within 30 days from the date Buyer discovers, or upon reasonable inspection should have discovered, such alleged claim (but in any event prior to the end of the Limited Warranty Period), and Buyer shall return the Beck Equipment in question, at Buyer's expense, to Beck for evaluation, in compliance with the terms stated in the "Return of Equipment" article in the Sales Contract. If Beck determines that the Beck Equipment fails to conform to the limited warranty, then, at Beck's sole discretion and its expense (subject to Buyer's conformity with the warranty), Beck will either: (i) repair or replace the Beck Equipment, without charge, at Beck's factory, or (ii) refund the purchase price of such Beck Equipment, less any applicable discounts, rebates, or credits. In no event will Beck's liability exceed the contract price actually paid for such Beck Equipment subject to a warranty claim. Beck makes no warranty, express or implied, with respect to any Buyout Item. This limited warranty is not transferable or assignable to any transferees of the Beck Equipment.

THIS WARRANTY IS EXPRESSLY IN LIEU OF ANY OTHER EXPRESS OR IMPLIED WARRANTY, INCLUDING IMPLIED WARRANTIES OF MERCHANTABILITY AND FITNESS FOR A PARTICULAR PURPOSE, AND ALL OTHER OBLIGATIONS OR LIABILITIES OF BECK. BUYER ACKNOWLEDGES THAT: (i) BECK HAS MADE NO INDEPENDENT INVESTIGATION OF THE SUITABILITY OF THE EQUIPMENT FOR BUYER'S INTENDED USE OR EXISTING SYSTEMS; AND (ii) BUYER HAS NOT RELIED UPON ANY REPRESENTATION OR WARRANTY MADE BY BECK OR ANY OTHER PERSON ON BECK'S BEHALF, EXCEPT AS SPECIFICALLY PROVIDED IN THE SALES CONTRACT. THIS SECTION SETS FORTH BUYER'S SOLE AND EXCLUSIVE REMEDY FOR ANY BREACH OF THE LIMITED WARRANTY SET FORTH IN THIS SECTION.

A 100% EMPLOYEE OWNED COMPANY

**BECK**

~ founded 1936 ~

SINCE 2021



**HAROLD BECK & SONS, INC.**

11 TERRY DRIVE • NEWTOWN, PENNSYLVANIA 18940 • USA

PHONE: 215-968-4600 • FAX: 215-860-6383 • E-MAIL: [sales@haroldbeck.com](mailto:sales@haroldbeck.com)

[www.haroldbeck.com](http://www.haroldbeck.com)

Made in USA

