

80-8801-00
Rev. 1.3

MODEL 88-109

Interfaces:
Wi-Fi
Pushbuttons



INSTRUCTION MANUAL



ELECTRIC ACTUATORS FOR INDUSTRIAL PROCESS CONTROL

INTRODUCTION

This manual contains the information needed to install, operate, and maintain Beck 88-100 Actuators, manufactured by Harold Beck & Sons, Inc. of Newtown, Pennsylvania.

The Beck 88-100 is a continuous duty, multi-turn actuator designed to provide precise position control of gate valves and other multi-turn valves, as well as large quarter-turn valves requiring up to 125 lb-ft (169 N•m) of torque.



IMPORTANT: This manual contains information that will make installation simple, efficient, and trouble-free. Please read and understand the appropriate sections in this manual before attempting to install or operate your actuator.



Group 75 compact rotary actuators ...

incorporate a very compact design with high temperature resistance and great mounting flexibility; making these actuators ideal for boiler windbox applications as well as all types of rotary valve applications in tight spaces.



Group 42 linear actuators ...

incorporate a long stroke design providing up to 1,000 lbs. (4450 N) of thrust. These actuators are ideally suited for burner air register type applications.



Group 22 digital actuators

Designed for accurate, reliable, modulating digital control of high torque applications. The actuator is ideal for use in large boiler applications, such as ID/FD fan dampers.



Group 11 rotary actuators

Provide precise position control of dampers, quarter-turn valves, fluid couplings, and other devices requiring up to 1,800 lb-ft (2 440 N•m) of torque.



Group 29 linear valve actuators

Ideally suited for globe valves from 1" to 8" (25 mm to 203 mm) diameter. Beck's unique Tight-Seater™ coupling provides positive seating of valves.



Group 31 compact rotary actuators

Particularly suited for coupling to ball, plug, and butterfly valves up to 4" (102 mm) diameter, and small dampers.

TABLE OF CONTENTS

Introduction	2
General Specifications	4
Features	5
Outline Dimension Drawings	6
Functional Block Diagram	8
Precautionary Information	10
General Operation Information	11
Installation	12
Mechanical	12
Electrical	13
Wiring	14
Start-up Checklist	15
Electronics	16
Wi-Fi Communication Interface	23
Menu Overview	26
Menu Descriptions	28
Configuration/Calibration	34
Maintenance	47
Troubleshooting	54
Index	58
Services	59

GENERAL SPECIFICATIONS

Actuator Power	480 Vac, 3-phase, 50/60 Hz (allowable tolerance +10%/-15%).
Power Draw	2500 VA.
Output Torque	125 lb-ft (169 N•m) (torque limit configurable from 10–100%).
Output Speed	60 RPM (configurable from 10–100%).
Travel Range / Max. Stroke Time	4–4,000 turns (digitally configurable) / 66.67 minutes
Operating/Storage Conditions	-40° to 70°C (-40° to 158°F); 0 to 100% relative humidity, non-condensing.
Communication Interface	Wi-Fi and Local Pushbutton / LED panel. DB9 Serial Commands and Modbus RTU (TCP optional) are also available and described in a separate instruction.
Demand Input Signal Range	4–20 mA.
Repeatability	7.5°.
Resolution	1/8 turn.
Position Feedback Signal	4–20 mA.
Isolation	Demand input and position Feedback signals are isolated from ground and the ac power line. Signal buffering provides 24 V dc isolation between the Demand and Feedback signals.
Position Status Indication	Alphanumeric LCD, configurable LEDs (red, yellow & green).
Action on Loss of Power	Stays in place.
Action on Loss of Input Signal (Power On)	Stays in place or runs to any preset position (configurable).
Stall Protection	If the motor tries to run in one direction for more than the DCM-calculated stall time (based on the travel setting), power will be removed from the motor.
Overtorque Protection	The DCM shuts off power to the motor if the measured output torque of the actuator exceeds 115% of the actuator rating (can be enabled/disabled).
Customer Wiring	Terminals 4–41 accept #12–22 AWG (3.31–.326 mm ²). Terminals 1–3 accept #8–18 AWG (8.36–.823 mm ²).
Mechanical Position Switches (Optional)	Two SPST cam-operated over-travel limit (CW, CCW) & four auxiliary switches (S1-S4) are available as a set. Switches are rated 10A, 125/250 Vac; 0.5A, 125 Vdc; 0.25A, 250 Vdc.
Handswitch	Permits local electrical operation, independent of Demand input signal. Five position, locking.
Handwheel	Provides manual operation without electrical power.
Motor	Continuous duty (no burnout) with locking mechanism.
Gear Train	Unique, all ferrous spur gear design is permanently lubricated.
Enclosure	Precision-machined aluminum alloy castings with a powder coat finish provide a rugged, dust-tight weatherproof enclosure. NEMA 4X, IP66, IP68, 3 meters/48 hours (internal water damage is not covered by warranty).
Mounting Orientation	Any orientation—no limitations.
Agency Approvals	CSA labeled (US & Canada).

FEATURES

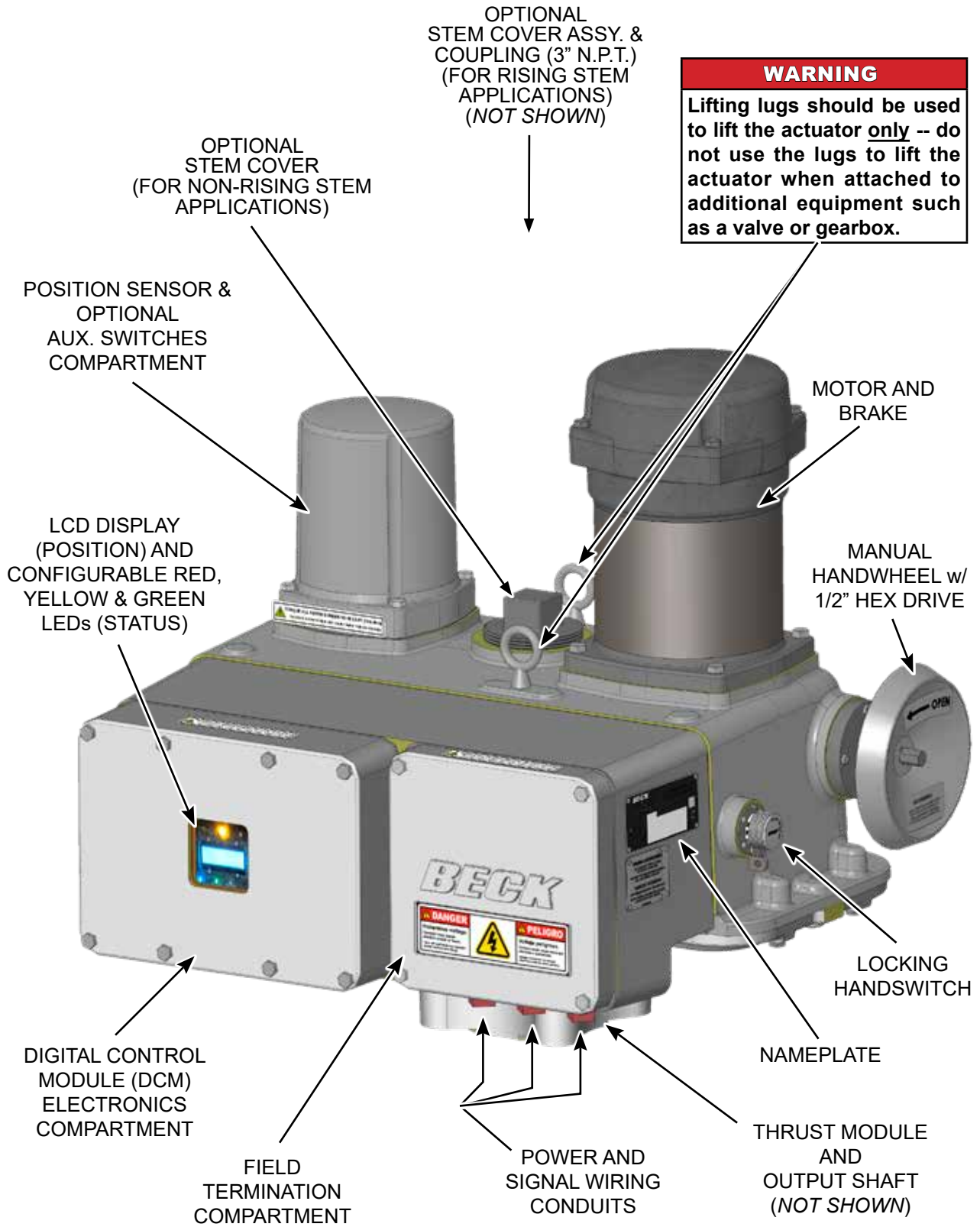

OUTLINE DIMENSIONS

FRONT VIEW

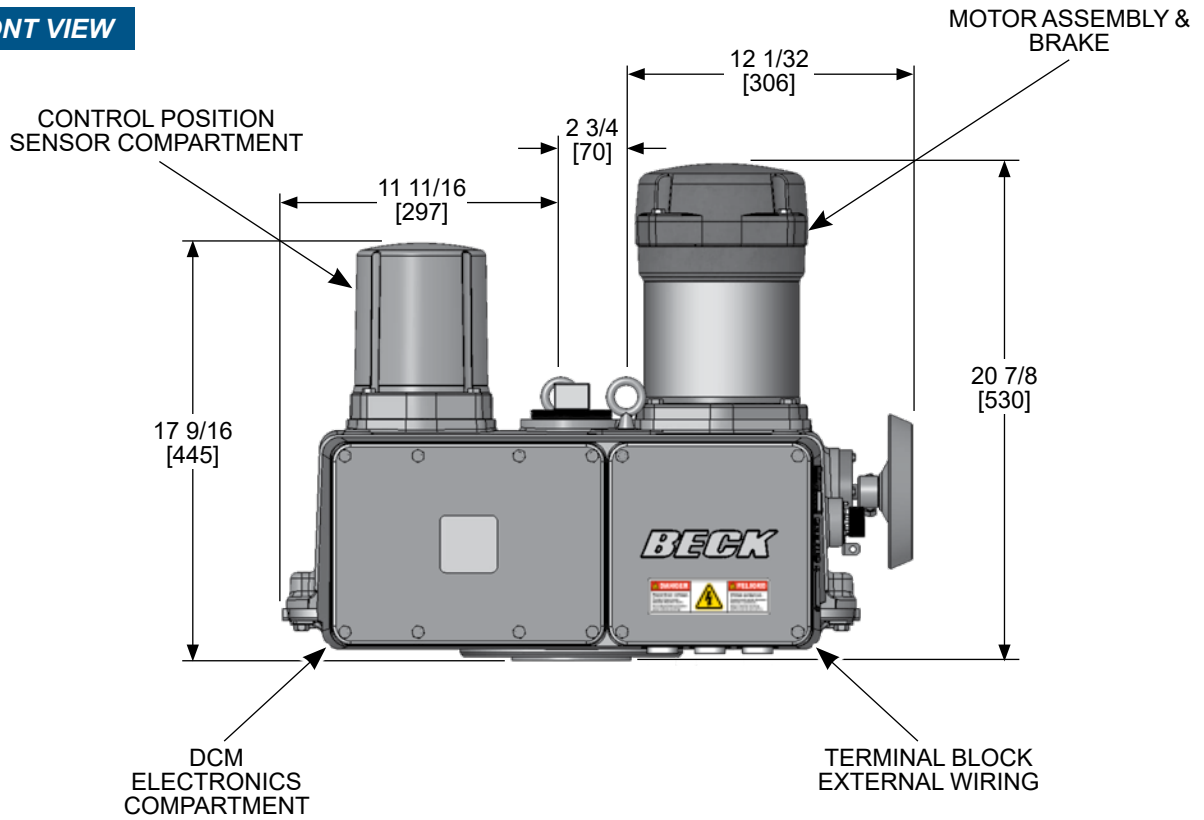

SIDE VIEW

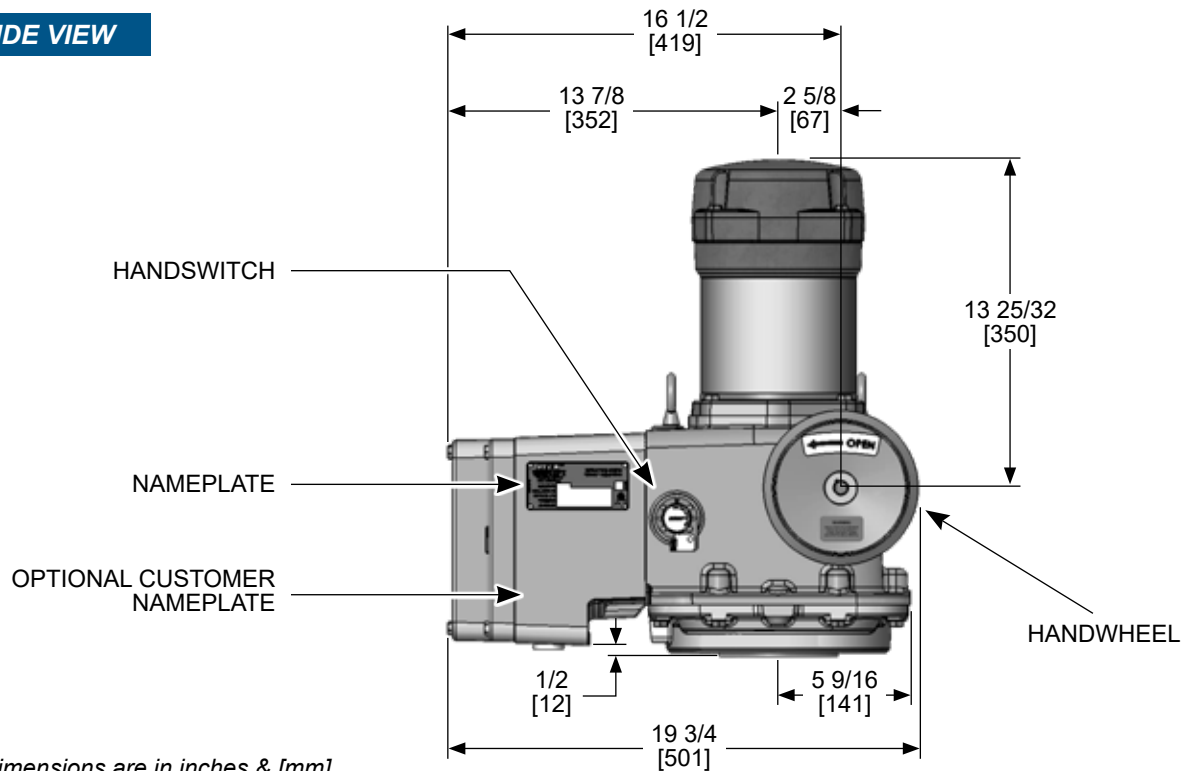

All Dimensions are in inches & [mm].
 All information is subject to change.
 Tolerance = +/- 1/4" [+/- 6 mm]

Beck Model	Rated Torque	Approximate Weight	Max Stem Size Rising (Thrust Module)	Max Stem Size Non-Rising
88-109	125 lb-ft (169.5 N•m)	230 lbs (104 kgs)	2" Thread	1.75"

BOTTOM VIEW

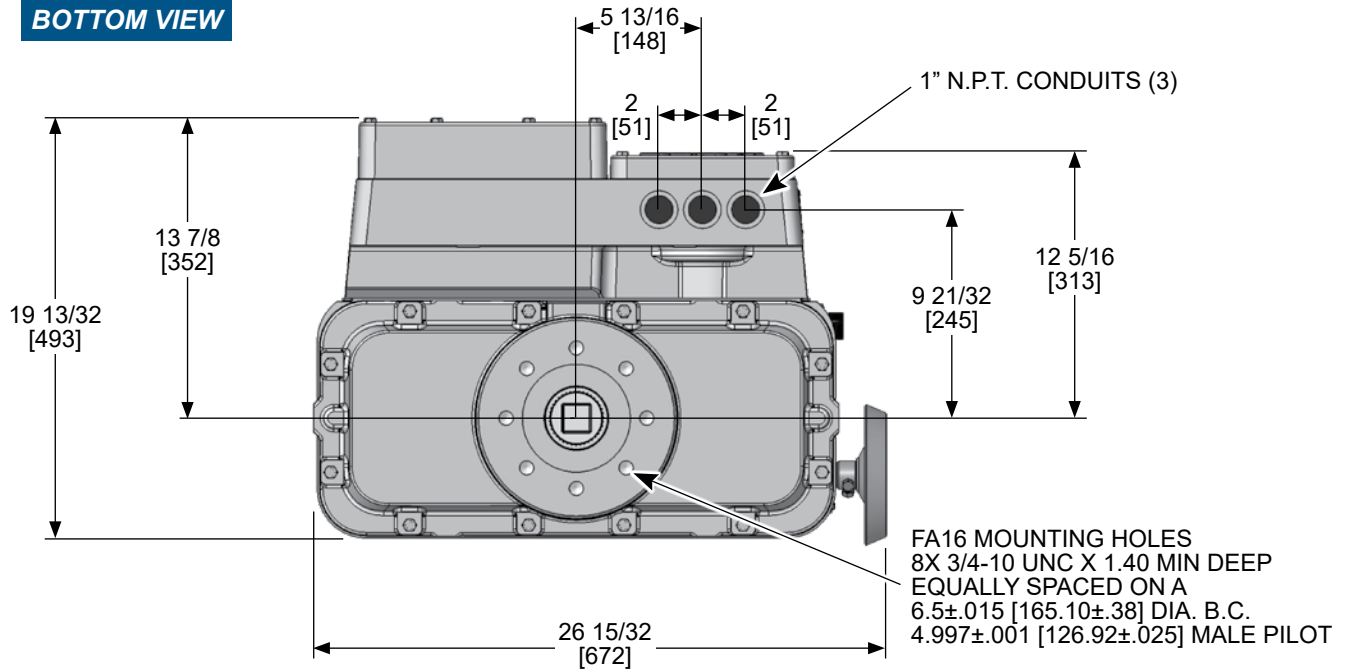

OPTIONAL STEM COVER:
• NON-RISING STEM (SHOWN)
OR
• RISING STEM

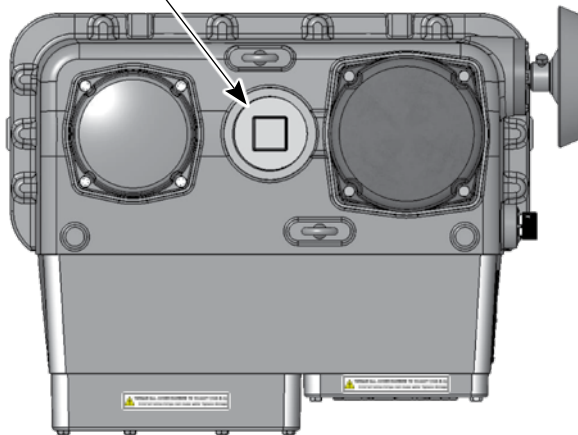

BOTTOM & FRONT VIEW W/ THRUST MODULE

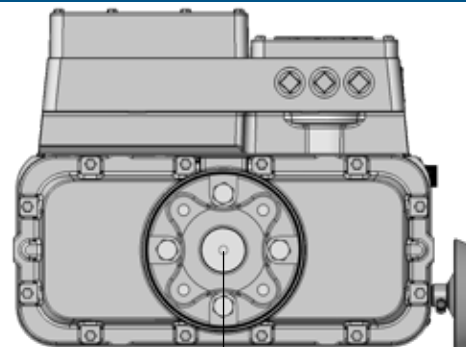

FA14 MOUNTING HOLES
4X 5/8-11 UNC X 1.35±.010 DEEP
EQUALLY SPACED ON A
5.5±.015 [139.7±.38] DIA. B.C.
3.747±.001 [95.7±.025] MALE PILOT

FA16 MOUNTING HOLES
4X 3/4-10 UNC X 1.60±.010 DEEP
EQUALLY SPACED ON A
6.5±.015 [165.10±.38] DIA. B.C.
4.997±.001 [126.92±.025] MALE PILOT

14 11/32 [364]

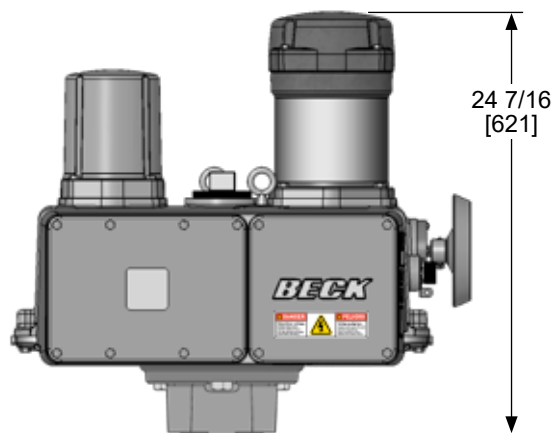

RECOMMENDED SCREW TORQUE

Description	Size (in.)	Torque (lb-ft)	Torque (N•m)
Body Screws	3/8-16	20	27.1
Cover Screws	5/16-18	10	13.6
Motor Screws	3/8-16	20	27.1
Thrust Module Screws	FA14 5/8-11	100	135.6
	FA16 3/4-10	175	237.3

FUNCTIONAL BLOCK DIAGRAM

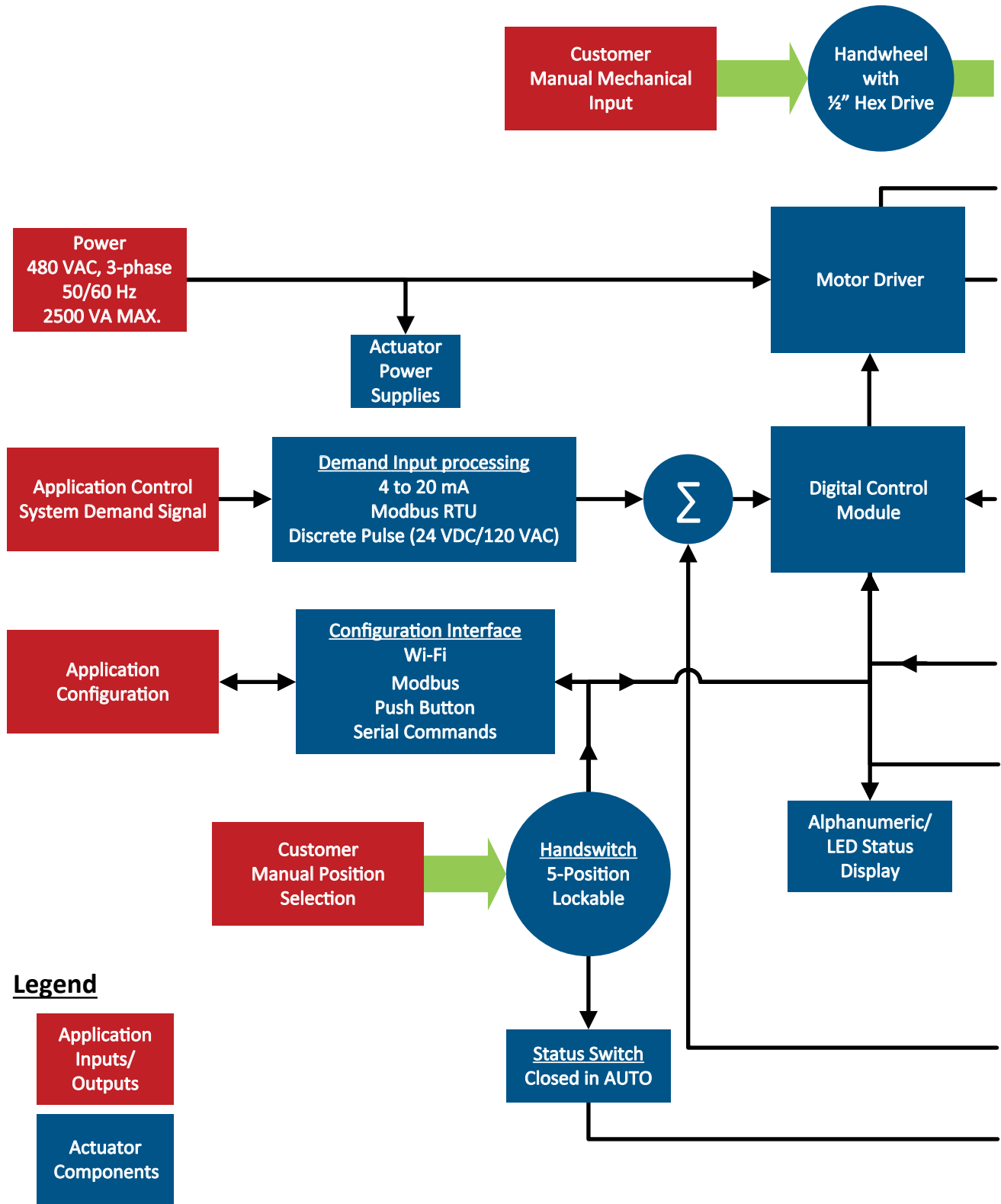

Legend

Application Inputs/Outputs

Actuator Components

Electronic/Software connection

Mechanical connection

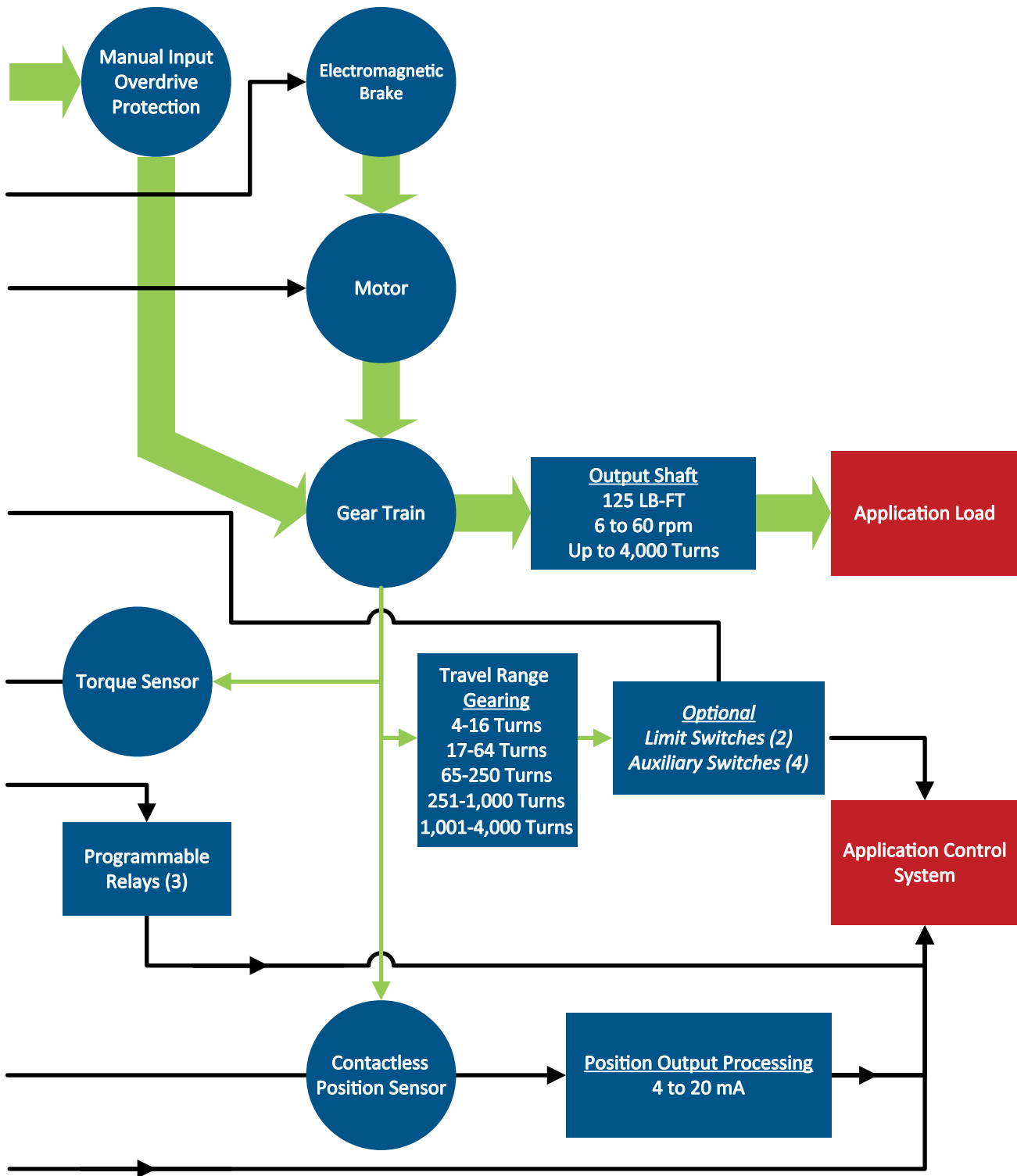

PRECAUTIONARY INFORMATION

SAFETY PRECAUTIONS



WARNING

Installation and service instructions are for use by qualified personnel only. To avoid injury and electric shock, do not perform any servicing other than that contained in this manual. Please read and understand the appropriate sections in this manual before attempting to install or operate your actuator.

STORAGE INFORMATION

Beck actuators should be stored in a clean, dry area where the temperature is between -40° to 70°C (-40° to 158°F).

Damage due to moisture while in storage is not covered by warranty.

VALVE ACTUATOR INSTALLATIONS



CAUTION

Working with valves installed in a pipeline can be dangerous. Take appropriate precautions when mounting to installed valves.

INSTALLATION—MECHANICAL

See the following instructions for details. Refer to the outline dimension drawings for physical dimensions and required clearances.

INSTALLATION—ELECTRICAL

See the following instructions for details regarding electrical installation.



CAUTION

For maximum safety, the Beck actuator body should be grounded. Use the green grounding screw in the wiring compartment of the actuator.



CAUTION

Always close covers immediately after installation or service to prevent moisture or other foreign matter from entering the actuator.



CAUTION

Under certain extreme circumstances, the non-metallic parts incorporated in the enclosure of this equipment may generate an ignition-capable level of electrostatic charge. Therefore the equipment shall not be installed in a location where the external conditions are conducive to the build-up of electrostatic charge on such surfaces. In addition, the equipment shall only be cleaned with a damp cloth.



CAUTION

Conduit entrances are provided for power and signal wiring. Temporary plugs are installed in the conduit entrances at the factory for shipping only and are not intended for permanent use. Prior to actuator operation, all conduit entrances must be properly sealed in accordance with National Standards or Regulatory Authorities.

GENERAL OPERATION INFORMATION

MODES OF OPERATION

There are four basic modes of operation:

- **Automatic**—remote electrical control
- **Override**—remote electrical control
- **Handswitch**—local electrical control
- **Handwheel**—local mechanical control

Any or all of these modes can be used to test basic operation of your actuator during start-up.

AUTOMATIC

When the Handswitch is placed in the AUTO position, the actuator is in automatic mode and responds to a Demand signal (also called the setpoint). The Control Board compares the Demand signal with the output shaft position. When a difference is detected between the Demand and Position (called error), the motor will rotate the output shaft until the Position matches the Demand.

OVERRIDE

Override operation can be used as a means of emergency operation or an alternate control method if 4-20 mA analog signaling is not available. PAT controls can be adapted by using external relays (solid state) to interface with the overrides.

Pulsed 120 Vac Control Override Inputs

Analog signal operation may be overridden by using relay logic input signals on the control override input terminals. CW (17), CCW (18), and STOP (19) terminals require connection to an ac source to perform the override, as shown below.

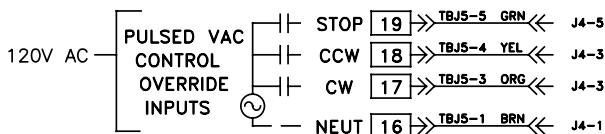

Dry Contacts Control Override Inputs

Analog signal operation may be overridden by using relay logic input signals on the control override input terminals. CW (29), CCW (30), and STOP (31) terminals require connection to COM (28) to perform the override, as show below.

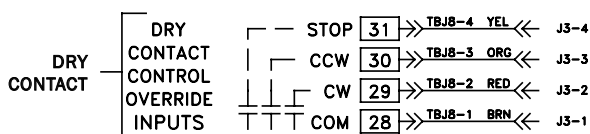

General Guidelines:

Use twisted pair 18 AWG wiring ≤500 ft., depending upon the application.

HANDSWITCH

A five position locking Handswitch (AUTO, STOP, CW, STOP, CCW) allows local electric control at the actuator. In either STOP position, the motor is blocked from running. In the CW or CCW positions, the motor runs to move the output shaft in the corresponding direction. When moving the output shaft using the Handswitch, the motor will stop when the over-travel limit switches are reached.

The Demand signal can position the actuator only when the Handswitch is in the AUTO position.

HANDWHEEL

Permits manual operation of the actuator without power and is particularly useful during initial installation or when power is not available. If power is available, the handswitch must be moved to the STOP position before manually operating the handwheel.

Extending through the middle of the handwheel is a 1/2" hex to allow a drill with a standard socket to more quickly move the actuator to the open or close position.

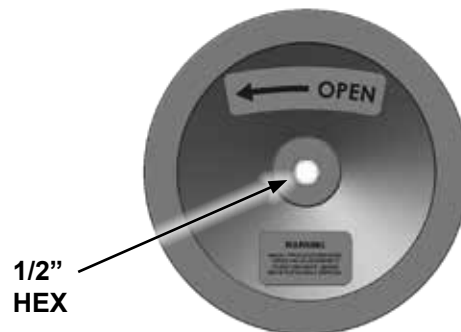

DISPLAY

A digital LCD display shows the position of the actuator (in percentage of configured span). Red and Green LEDs indicate the actuator has reached the open or closed position (configurable). The Yellow LED indicates that the actuator is in between the open and closed positions.

Power, Status, USB and Wi-Fi LEDs are also on the display board.



INSTALLATION Mechanical

Beck Group 88 actuators may be installed in any convenient orientation, because the gearing does not require an oil bath. Refer to the outline dimension drawings for physical dimensions.

UNITIZED VALVE/ACTUATOR ASSEMBLY INSTALLATION

Inspect the valve and pipe flanges to ensure they are clean. Be certain that other pipelines in the area are free from pipe scale or welding slag that could damage the gasket surfaces.

Carefully lift the assembly and position the valve in the pipeline. Install and tighten the flange bolts according to the valve and/or gasket manufacturer's instructions.

NOTE: The valve may have undergone temperature variations in shipment. This could result in seepage past the stem seals. Refer to the valve manufacturer's maintenance instructions for packing adjustments, if required.

VALVE ACTUATOR INSTALLATION



CAUTION

Working with valves installed in a pipeline can be dangerous. Take appropriate precautions when mounting to installed valves.

Whenever an actuator is being mounted on a valve, refer to the valve manufacturer's maintenance manual for specific valve-related instructions. Consult the Beck Valve Mounting Specification sheet shipped with the actuator for specific instructions on assembly of the Beck actuator and mounting hardware to the valve. It is good practice to remove the valve from service, if possible.

DIRECTION OF TRAVEL

The image below shows the default CW/OPEN direction of travel looking up into the actuator. Note that after OPEN & CLOSE positions are configured, the direction of travel can be changed.



Beck Group 88 actuators are shipped fully assembled and ready for installation when stem thread information has been provided for machining the stem nut. A detailed Valve Mounting Specification (VMS) is typically provided.

1. A crane/hoist with a minimum rated capacity of 500 lbs. will be needed to lift the actuator.
2. Ensure the mounting surface of the valve is secure and free of debris.
3. Ensure the valve stem is free from debris and properly lubricated as per the valve manufacturer's specifications.
4. Install mounting plates/bracket with provided hardware as detailed in the VMS instructions.
5. For non-rising stem or additional gearbox applications, install the stem adapter onto the valve or gearbox stem. For rising stem applications, thread the thrust module down from the top of the valve stem until it meets the mounting surface. Align the thru holes in the mounting surface to the tapped holes in the thrust module.
6. For non-rising stem or additional gearbox applications, skip to step 7. Secure the thrust module to the valve using the provided screws and washers—(4) 5/8-11 (100 lb-ft [136 N•m]) or (4) 3/4-10 (175 lb-ft [237 N•m]). Ensure the thrust module is secure.
7. Utilizing the lifting bolts on the actuator (see page 5 for location and warning), use the crane/hoist to position the actuator above the valve stem. Ensure the stem is free to pass through the actuator without obstruction.
8. Carefully lower the actuator over the valve stem until the output shaft reaches the spline of the stem nut. Using the actuator handwheel (see page 5 for location), rotate the output shaft until it meshes with the spline.
9. Carefully, continue lowering the actuator until the gearbox meets the flange of the thrust module. Confirm desired orientation by aligning the thrust module with the appropriate tapped holes in the gearbox.
10. Secure the actuator to the thrust module using the (4) 3/4-10 screws and washers provided. Tighten the screws to 175 lb-ft (237 N•m). Ensure the actuator is properly secured to the thrust module.
11. Place cover over the valve stem and secure onto the cover adaptor, adhesives optional.
12. If desired, drill weep holes into the stem cover or cover adaptor. Ensure all weep holes are free of obstructions.

INSTALLATION Electrical



WARNING

LETHAL VOLTAGE POTENTIAL!
Before removing the terminal cover, ensure that the actuator is disconnected from power.

POWER QUALITY

Power quality disturbances such as power outages, transient voltages, harmonic distortions, and electrical noise will adversely affect your actuator performance. Protecting your actuator from these conditions can reduce downtime and promote longer life for the equipment. Following the industry-accepted standards below will help protect your actuator.

- ✦ Select wiring materials according to the correct ampacity ratings dictated by national and local regulations.
- ✦ Shielded, twisted pair cables can be used for signal connections to avoid being affected by electrical noise. These signal wires, based on Noise Susceptibility Level (NSL) per IEEE-518, fall into the level 1 classification. A braided shield will be more effective than a wrapped foil shield. Signal wire shields should be connected to the actuator casting grounding screw. If grounding at the signal source is required, then the shield should not be grounded at the actuator.
- ✦ Raceways such as conduits and trays must be grounded at both ends to properly meet immunity requirements.
- ✦ A power ground connection should be made between the power source and the Beck actuator. Grounding connections including wire and metal conduit are permitted, but the actuator-grounding conductor may not be connected to a structured metal frame of a building.
- ✦ Surge suppression equipment that meets Underwriters Laboratory (UL) Standard 1449 may be used to protect against transient voltage conditions.
- ✦ Power Conditioners may be used to regulate the supply voltage and maintain a constant voltage level. They are helpful in protection against voltage sags and swells, as well as some measure of electrical noise protection.
- ✦ Harmonic filters may be used to minimize the effects of supply voltage waveform distortions and are used in applications that incur a large amount of high-frequency electronic noise.

ELECTRICAL INSTALLATION

Three 1" N.P.T. conduit connections are provided for power and signal wiring to the actuator. Conduits should be routed from below the actuator so that condensation and other contaminants flow away from the conduit.



CAUTION

Temporary plugs are installed in the conduit entrances at the factory for shipping only and are not intended for permanent use. Prior to actuator operation, all conduit entrances must be properly sealed in accordance with National Standards or Regulatory Authorities.

Power and signal wires should be routed to the actuator separately and be either shielded cables or installed in conductive conduit and/or cable trays.

Refer to the wiring diagram furnished with your Beck actuator for proper power and signal connections. The wiring diagram is shipped with each actuator inside the terminal compartment. If there is no wiring diagram available, you may obtain a copy from Beck by providing the Serial number of your actuator.

For maximum safety, the Beck actuator body should be grounded. Use the green grounding screw in the wiring compartment of the actuator.

TERMINAL SCREW TORQUES

Each terminal screw should be torqued to the proper specification upon landing the wire. See next page for terminal connections.

TERMINALS	TORQUE	
	(LB-IN)	(N•M)
1-3	16	1.8
4-41	12	1.4



CAUTION

Always close covers immediately after installation or service to prevent moisture or other foreign matter from entering the actuator.

INSTALLATION Wiring

TERMINAL CONNECTIONS

The terminal blocks are located in a separate, gasketed compartment at the front of the actuator. AC line voltage connections are made on terminal designations 1–3.

Terminal screws will accept standard spade or ring terminals. Terminals 4 through 41 accommodate #22 AWG and will accept #12–22 AWG (3.31–.326 mm²). Terminals 1 through 3 accommodate #18 AWG and will accept #8–18 AWG (8.36–.823 mm²). For wiring versatility, the screw-down clamp design will also accept unterminated wire.

Typical wiring connections are shown below. Each actuator includes four auxiliary switches (wiring connections are described in the Configuration/Calibration section).

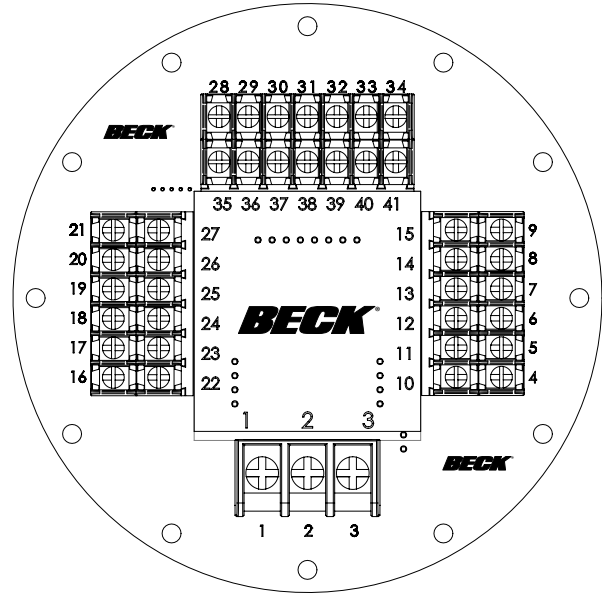

TYPICAL WIRING CONNECTIONS

(Each actuator has a specific wiring diagram inside the terminal compartment)

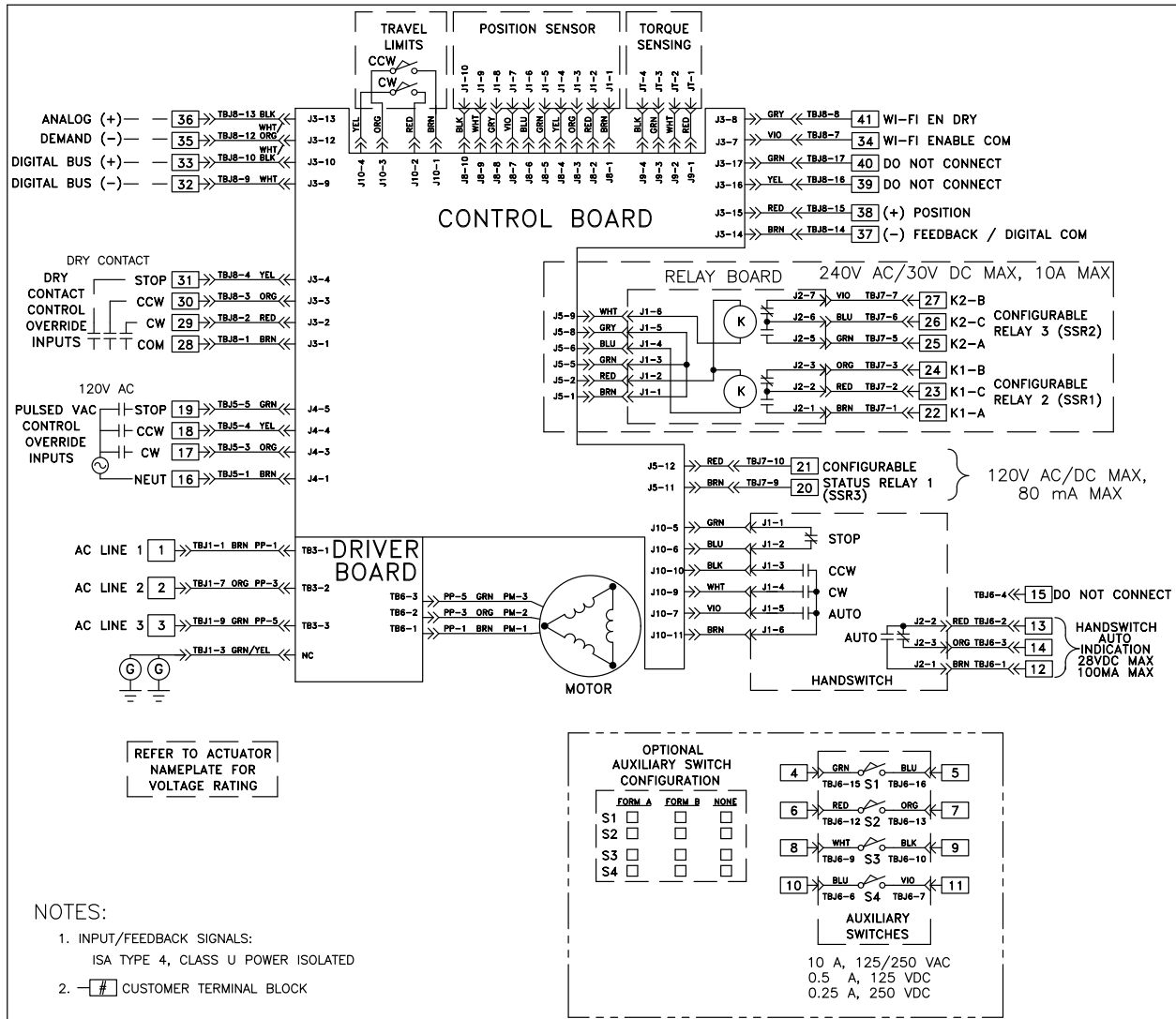

START-UP

NOTE: Your Beck actuator was shipped from the factory ready for installation; no electrical adjustments are required before placing it in operation. Each actuator is set up and calibrated to the specifications that were written into the equipment order. However, if optional mechanical position switches were ordered, they are preset by the factory outside of the operating limits of the actuator and must be reset by the customer for their specific requirements (see page 34).

START-UP CHECKLIST

The following list provides some basic checks that should be performed before placing your actuator into operation.

- Inspect the location and the mounting surface.
- Confirm the actuator is receiving the appropriate operating voltage as shown on the nameplate.
- Using the Handswitch, confirm the actuator moves fully to both the CW and CCW ends of travel.
- Confirm the actuator has a 4–20 mA Demand signal attached to terminals 36 (+) and 35 (–).
- Place the Handswitch in AUTO and vary your Demand signal from 0% to 100%.
- Verify that the output shaft is moving to the desired 0% position with a 0% Demand signal and moving to the 100% position with a 100% Demand signal. If they are reversed, see the Configuration/Calibration section of this manual for instructions on how to change the direction of output shaft rotation.

HANDSWITCH & HANDWHEEL DIRECTION LABELS

A label sheet (see image below) has been provided with your order that includes labels for the Handswitch and Handwheel. If desired, these labels could be used to show the appropriate direction of travel after the actuator has been set up.

1. Using a clean, dry cloth or rag, wipe the surface of the Handswitch and Handwheel. Ensure there is no grease or dirt on the surface that will prevent proper adhesion with the new labels.
2. Remove the backing from the desired Handswitch label to expose the adhesive.
4. Carefully align the new label in the correct orientation using the indicator as a guide. Press the new label into place over the existing Handswitch label.
5. Gently rub the surface of the label to seal it into place.
6. Properly orient the new Handwheel label and press onto the flat surface of the Handwheel near the outer edge, aligning the curvature of the label with that of the Handwheel.
7. Gently rub the surface of the label to seal it into place and ensure it is flat against the Handwheel.

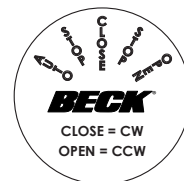
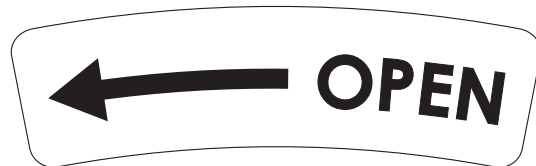

ELECTRONICS

CONTACTLESS (MAGNETIC VECTOR) POSITION SENSOR (CPS)

The 88-109 actuator uses technology that measures the output shaft position with magnetic vector sensing.

The sensor continuously transmits the magnet vector angle to the Digital Control Module, which then compares the sensor limit values with the live sensor reading to calculate the actual output shaft position.

If the sensor is ever replaced, the actuator should be recalibrated. The procedure for replacing and recalibrating the sensor is outlined in the Maintenance section of this manual.

The control end cover houses the optional mechanical position switch assembly, which includes two mechanical over-travel limit switches (CW, CCW) and four cam-operated auxiliary switches (S1–S4). If so equipped, the control end assembly is mounted on top of the position sensor assembly (see image at right).

In order to establish the range of turns to set the optional switches, a takeoff gear is provided with the control end assembly and needs to be installed on the appropriate post of the position sensor assembly (see image at right, shown pointing at the 4,000 max. turns post). The position of the take off gear will be based on the maximum of the turn option ranges shown below.

0 – 16
17 – 64
65 – 250
251 – 1,000
1,001 – 4,000

The takeoff gear must be slid completely over the appropriate post until flush with the retaining ring. Torque the socket set screw (#6-32 x 0.188) to 10 lb-in (1.1 N•m).

NOTE: After the takeoff gear has been installed, the mechanical position switches should be set as desired (see page 34).

OPTIONAL CONTROL END ASSEMBLY WITH SIX MECHANICAL POSITION SWITCHES

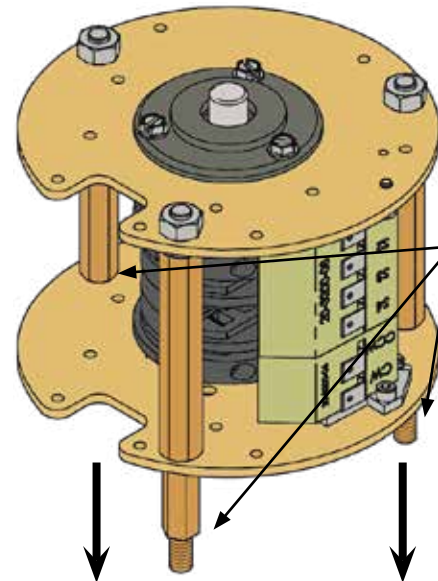

TIGHTENED TO POSITION SENSOR ASSEMBLY WITH 1/4-28 HEX NUTS (3) PLACES (NOT SHOWN, TORQUE TO 7 LB-FT).

#6-32 x 0.188 SOCKET SET SCREW (TORQUE TO 10 LB-IN)

TAKEOFF GEAR (ADJUSTABLE-5 POSITIONS BASED ON MAX. TRAVEL RANGE)

POSITION SENSOR ASSEMBLY

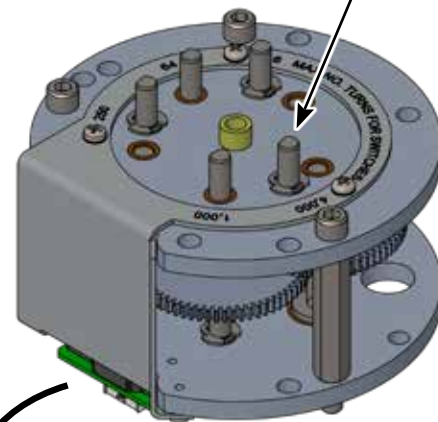

POSITION SENSOR



DIGITAL CONTROL MODULE (DCM)

The Digital Control Module (DCM) is the electronics chassis assembly which includes the Display Board, the Control Board and the Driver Board. The DCM is a micro-processor based circuit board assembly that serves as the actuator's control center.

The main function of the DCM is to position the actuator's output shaft. It compares the Demand (either Analog 4–20 mA signal or Modbus setpoint) to the actuator position sensor reading. If a difference exists between Demand and Position (the error), the DCM synthesizes the motor waveform that will move the output shaft (through the gear train) to correct the imbalance. Basically, the DCM controls the motor to appropriately reposition the actuator.

The DCM layout is illustrated and described on the following pages.

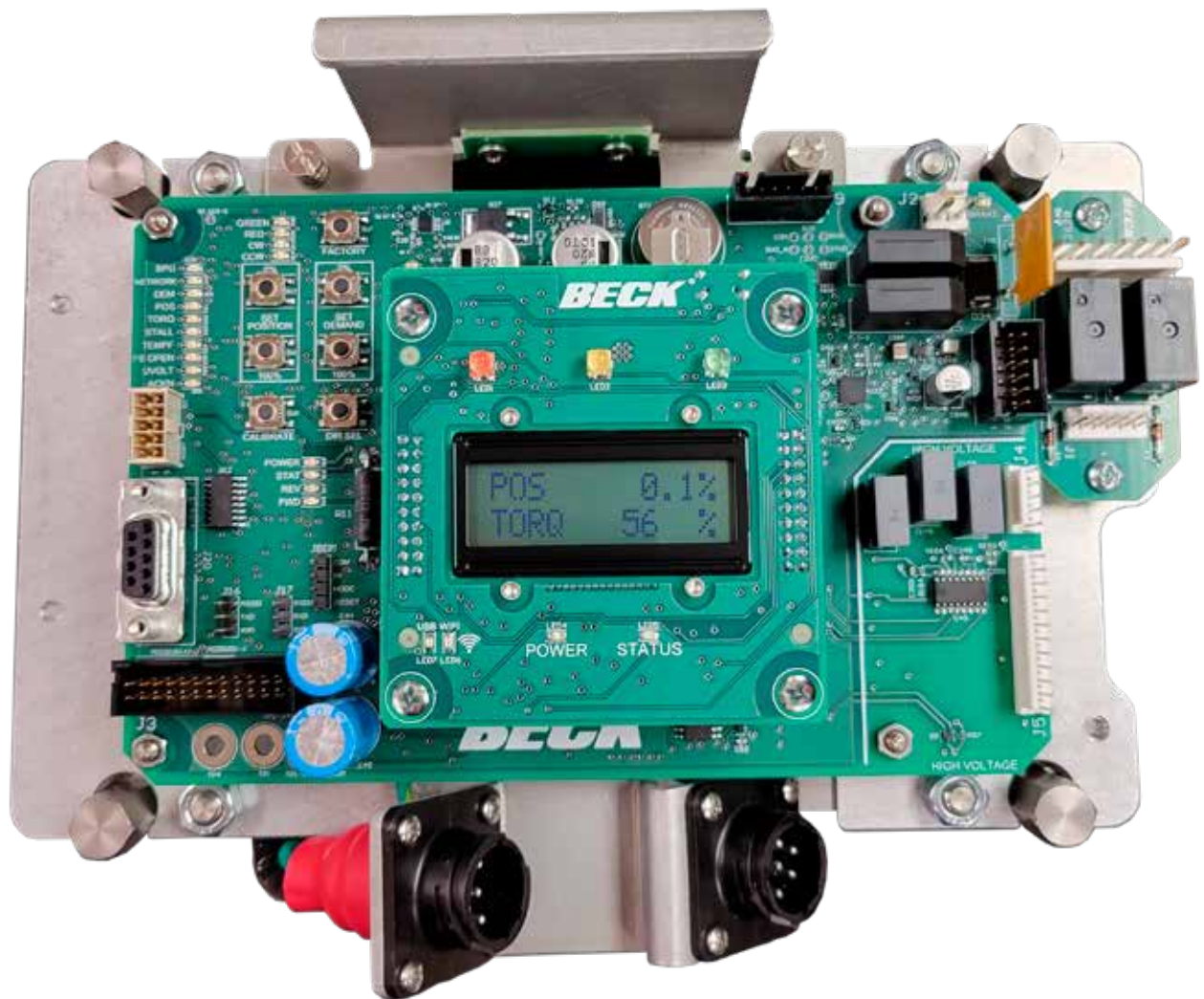

ELECTRONICS

DCM FUSE LOCATIONS

Three 8A, 600 Vac fuses (F1, F2 & F3) are located on the P.C. board attached to the chassis handle. These fuses should be replaced with the exact same part (see "SPARE PARTS" table on page 55).

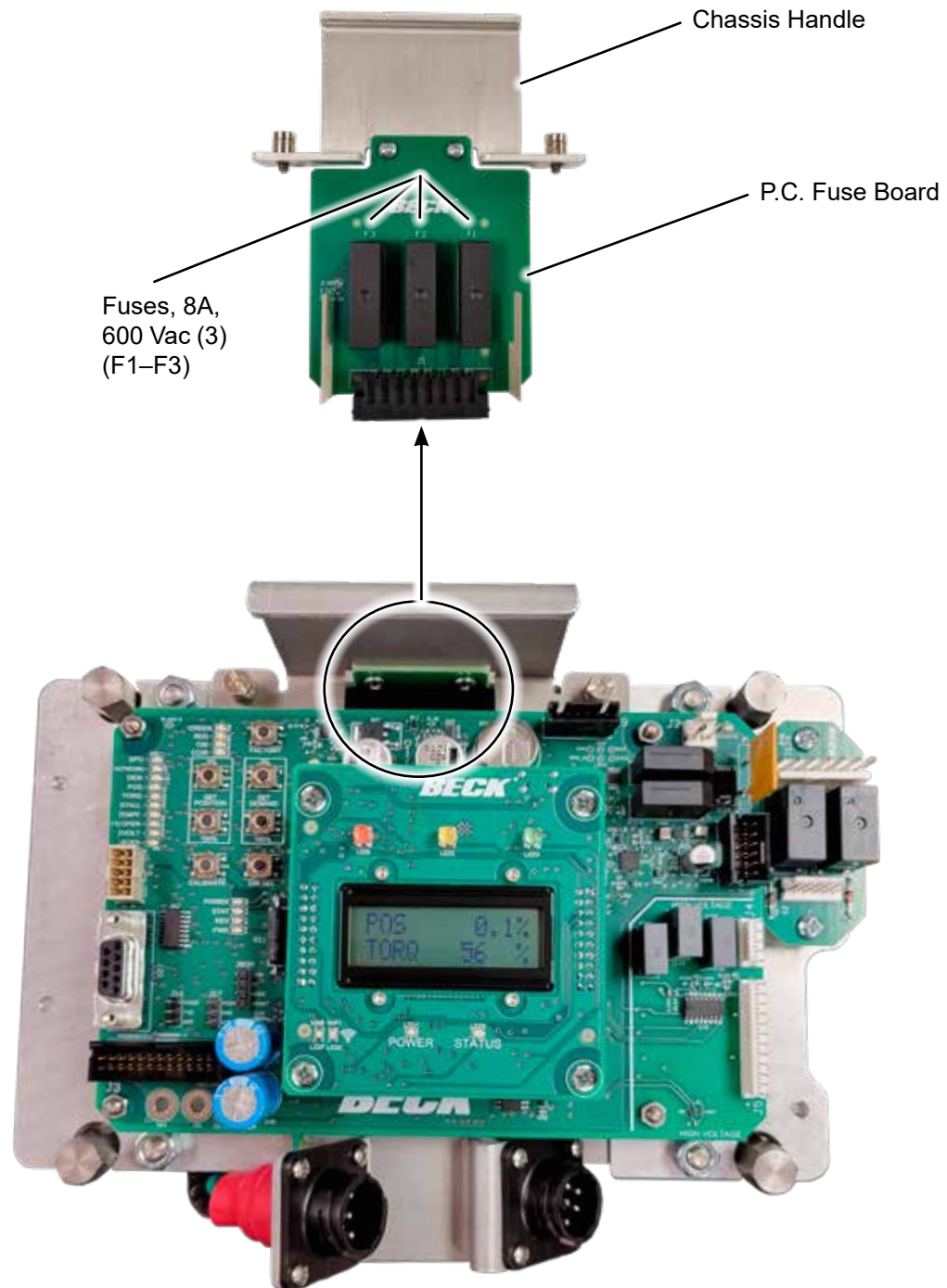

DCM SETUP AND CONFIGURATION INTERFACES

The 88-109 actuator has several standard interfaces that allow configuration and setup of the DCM:

1. DCM-mounted pushbuttons
2. A non-intrusive Wi-Fi interface
3. An RS232 Serial interface for use with Serial commands
4. May be configured through Modbus RTU (TCP optional) if communicating via Modbus to the control system.

PUSHBUTTONS

The DCM is equipped with pushbuttons that can be used to calibrate the Demand signal and configure 0% and 100% positions. It may also be used to configure the direction of output shaft rotation for increasing Demand or to return the electronics to factory settings.

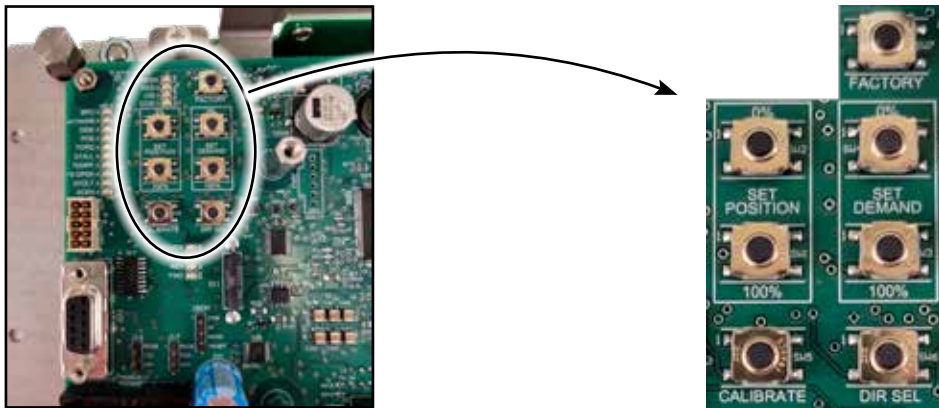

Wi-Fi

The Wi-Fi interface is described in detail beginning on page 23.

SERIAL COMMANDS & MODBUS interfaces are detailed in separate instructions (80-8801-10 & 88).

ELECTRONICS

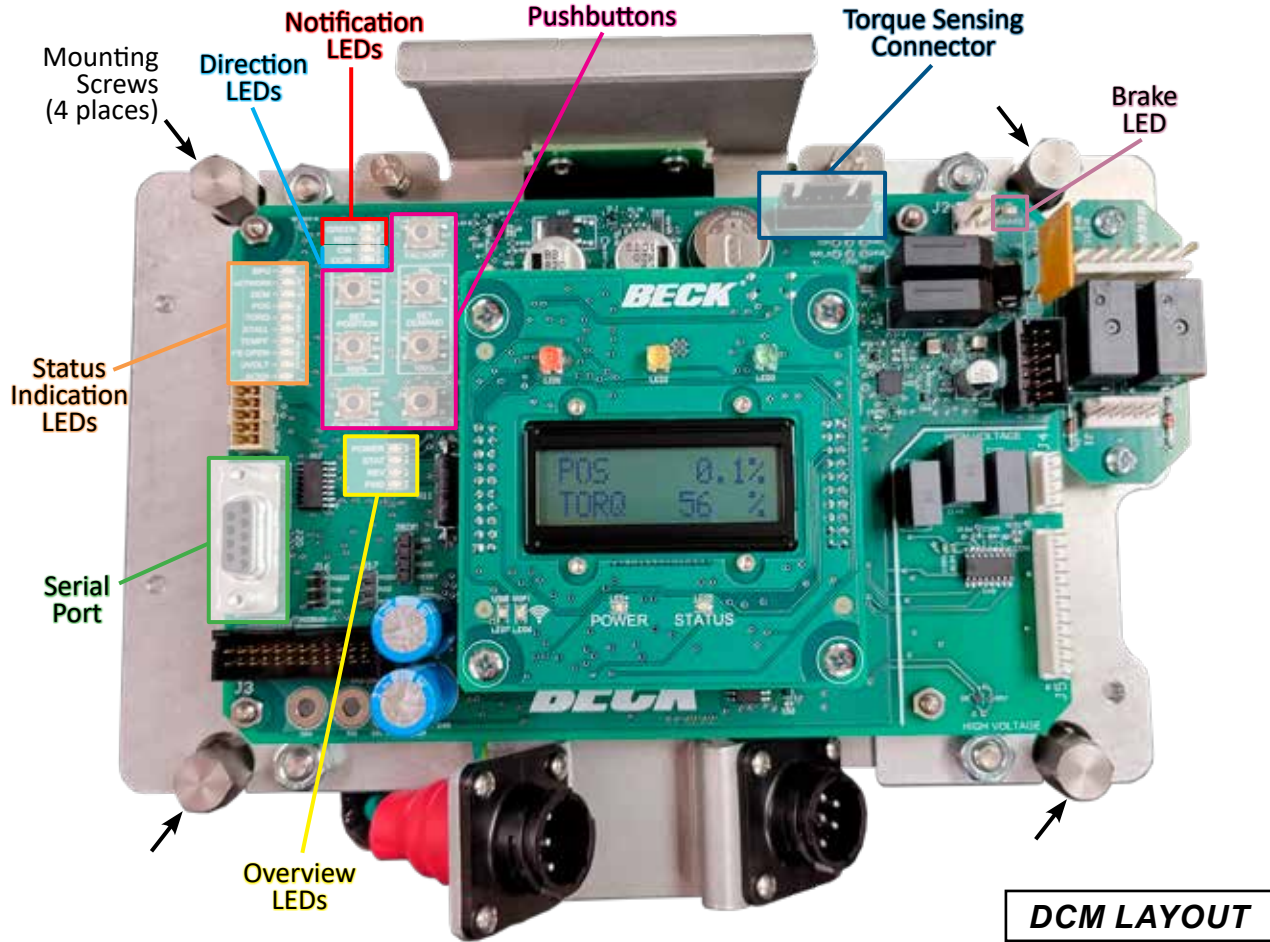

OVERVIEW LEDs

Located on the Control Board (pictured above), these LEDs indicate the basic, real-time state of the actuator. A description of each LED follows.

POWER

This green LED illuminates when power is applied to the actuator. This LED pulses from bright to dim indicating the Control Board is operational.

STAT

This red LED illuminates during a system alarm (see Status Indication LEDs, next page). Explanation of the specific alarm is available through the Modbus or Serial interface. See the Troubleshooting section for additional information.

REV

This green LED illuminates when the actuator is receiving a Demand signal less than its position.



FWD

This green LED illuminates when the actuator is receiving a Demand signal greater than its position.

NOTIFICATION LEDs

GREEN & RED

Indicates the position of the actuator (mimics the lights on the Display Board).



DIRECTION LEDs

These green LEDs indicate the direction of travel resulting from an increasing Demand signal.



BRAKE LED

When lit, this green LED indicates that the brake has been disengaged.



STATUS INDICATION LEDs

When the “STAT” LED is lit, a red indication LED(s) will light to reveal the actuator condition(s). An alarm is available at terminals 20 & 21. When the condition is corrected, the status will automatically reset.

BPU

N/A.

NETWORK

Blinks to indicate receipt of a Modbus command.

DEM

Loss of the Demand input signal.

POS

The Position signal is outside of range limits. The lower limit is –5% and the upper limit is +5% of the calibrated range. May also indicate an internal wiring failure.

TORQ

This LED indicates that excessive torque is present (over 105% of the actuator rating).

STALL

The actuator is in a stall condition and stall protection has been activated.

TEMPF

The internal temperature of the actuator is outside of rating.

FB_OPEN

External position Feedback signal is enabled, but not wired to an external load or the wiring has failed between the actuator and the monitoring device.

UVOLT

Operating voltage is too low for the actuator to function properly.

ACKN

Acknowledges when a calibration procedure has been completed.

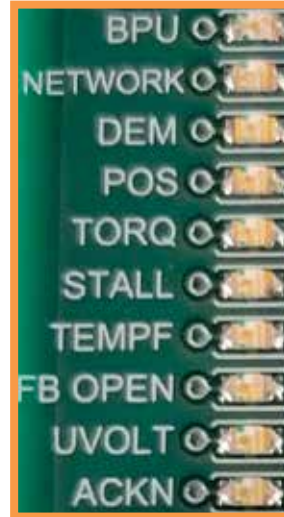

PUSHBUTTON CONTROLS

The seven pushbuttons on the Control Board are used for calibration. When pressing a pushbutton, pressure should be maintained until the “ACKN” LED is lit (see above); this confirms receipt of the pushbutton command. See the Configuration/Calibration section of this manual for further explanation of calibration procedures.

CALIBRATE

This button must be pressed and held simultaneously with another pushbutton to perform a calibration.



CAUTION

Pressing the following buttons may change calibration and cause the actuator to reposition.

SET POSITION 100%

Press to designate the current position of the output shaft as the 100% position for actuator movement (this will correspond to a 100% Demand signal).

SET POSITION 0%

Press to designate the current position of the output shaft as the 0% position for actuator movement (this will correspond to a 0% Demand signal).

SET DEMAND 100%

Press to designate the current analog Demand input signal as 100% Demand.

SET DEMAND 0%

Press to designate the current analog Demand input signal as 0% Demand.

DIR SEL

Press to change the direction in which the output shaft will rotate in response to an increasing Demand signal.

FACTORY

Press to reset calibration to the factory settings.

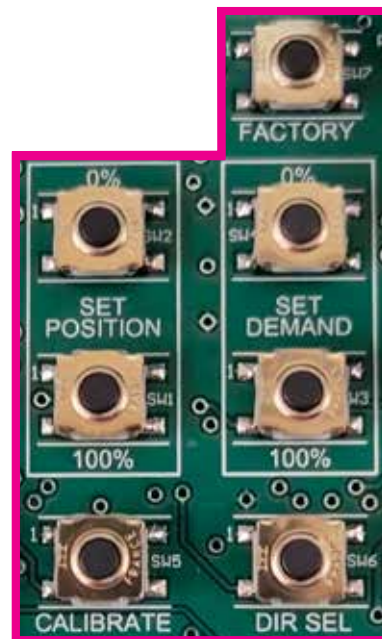

ELECTRONICS

DCM SIGNAL TEST POINTS

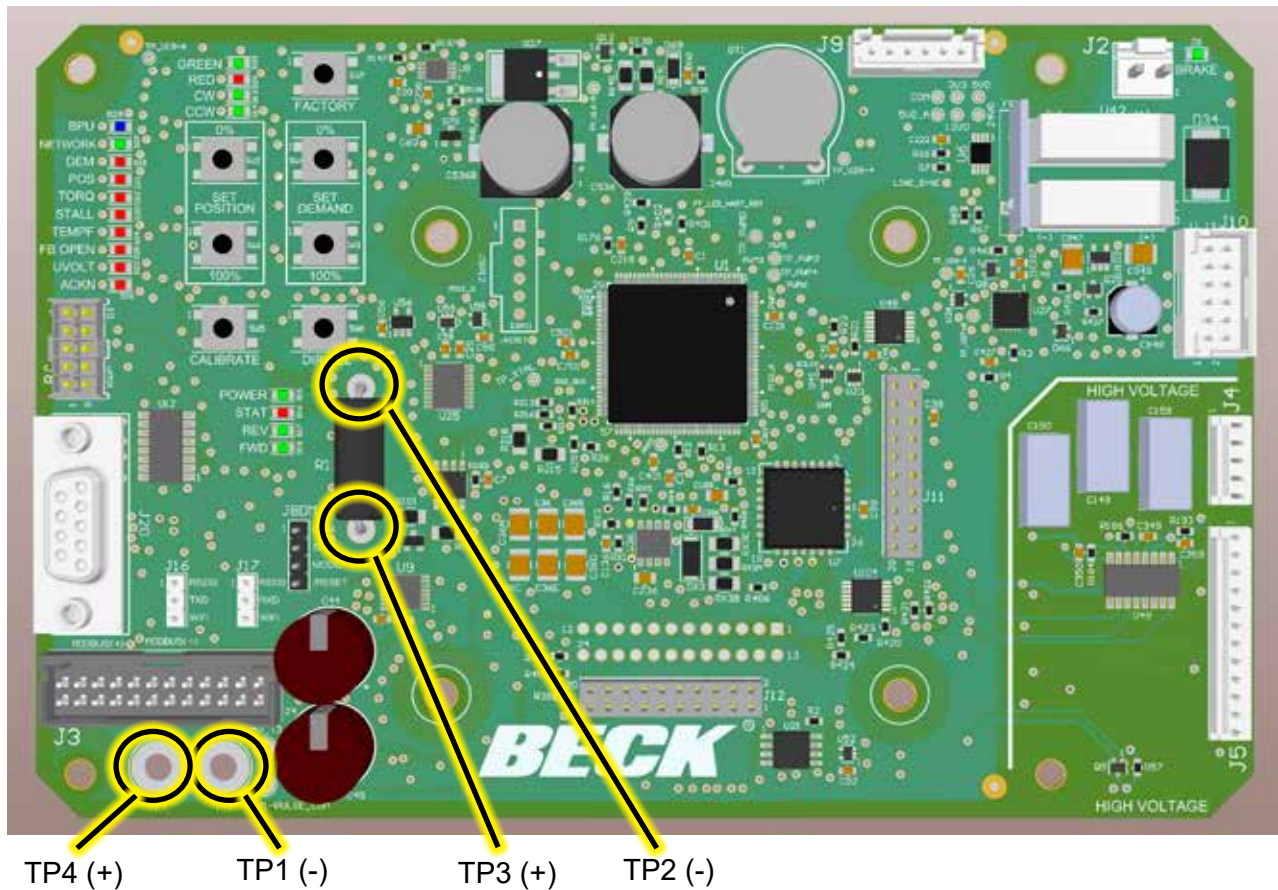

SIGNAL TEST POINT PAIRS

TEST POINT PAIR	SIGNAL DESCRIPTION	EXPECTED RANGE
TP3 (+) and TP2 (-)	Demand Analog Signal. The actual analog Demand current (4–20 mA) dropped across a precision 250Ω resistor (1–5 Vdc).	1.0–5.0 Vdc (linear). At 4 mA Demand, the voltage will equal 1.0 Vdc. At 12 mA Demand, the voltage will equal 3.0 Vdc. At 20 mA Demand, the voltage will equal 5.0 Vdc.
TP4 (+) and TP1 (-)	Position Sensor Analog Signal. A voltage that represents the percentage open scaled from 1–5 Vdc.	1.0–5.0 Vdc (linear). At 0% shaft position, TP4 equals 1.0 Vdc. At 50% position, TP4 equals 3.0 Vdc. At 100% shaft position, TP4 equals 5.0 Vdc.

Wi-Fi COMMUNICATION INTERFACE

All Beck 88-109 actuators are equipped with a Wi-Fi interface to allow non-intrusive setup and configuration. This manual details Wi-Fi and Pushbutton control. DB-9 Serial Commands and Modbus interfaces are also available and are described in a separate instruction.

Use of the Wi-Fi interface requires any Wi-Fi capable device such as a phone, tablet or computer equipped with a web browser; e.g., Chrome, Edge, Firefox, Safari, etc.

Establishing the Wi-Fi connection is easily accomplished. Each Beck actuator creates its own unique Wi-Fi network and embedded web page. The Wi-Fi network name will be shown with the word “Beck” followed by the actuator serial number such as “Beck_88-109-189400-00-00”. This serial number is also shown on the nameplate attached to the side of the actuator.

Wi-Fi connection instructions follow.



Wi-Fi Communication Interface

SECURITY

All Beck actuators are shipped from the factory configured and tested to the customer purchase specification. The Beck Wi-Fi module is integral to the actuator and protected with three levels of security:

1. Chassis jumpers (J16 & J17)
2. Terminal write protection jumper (terminals 34 & 41)
3. Password (configurable)

In order for Wi-Fi to operate properly, a two pin jumper must connect "TXD" (transmit) and "WiFi" (J16). Another jumper must connect "RXD" (receive) and "WiFi" (J17). See chassis image below.

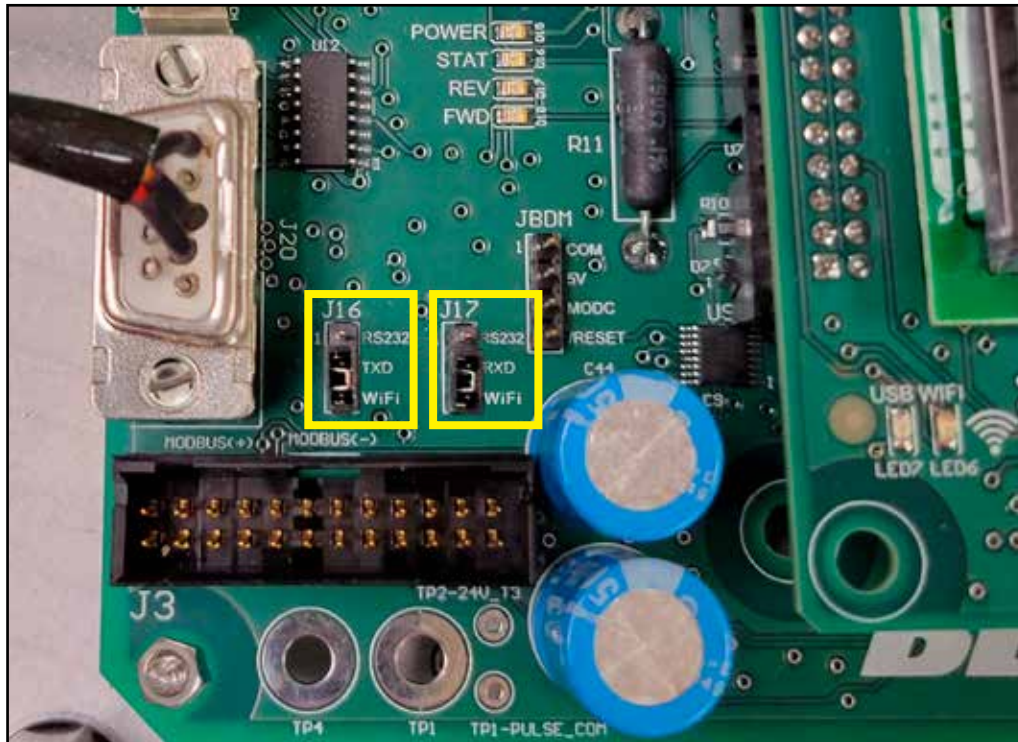

NOTE: After setup is complete, the jumper between terminal 34 & 41 should be removed to prevent accidental changes to the Wi-Fi settings (see image below).

BECK Wi-Fi CONNECTION INSTRUCTIONS

The connection instructions below are intended to provide a quick overview - there may be some discrepancies depending on your connecting device.

1. From the home screen, click on the “Settings” icon.
2. Click on “Connections” then “Wi-Fi” to see the list of available networks. From the list, choose the network that begins with “Beck” and includes the actuator serial number.
3. After selecting the Beck actuator, a password prompt will appear. The factory-set password is “88109000”. If desired, this password may be changed.
4. After the password has been successfully entered, the Wi-Fi network will appear with the word “Authenticating”.
5. When authentication is successful, the word “Connected” will then appear.
6. At this point, open a web browser; e.g., Google chrome, Microsoft Edge, etc. In the address bar, type “beck.local”.
7. The Beck Home Menu page will then appear.

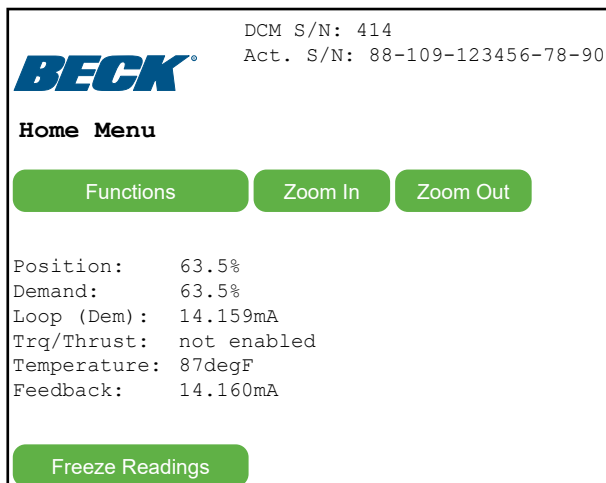

Beck Wi-Fi menus are designed to be intuitive and easy to use. Menus have “Zoom In” and “Zoom Out” buttons to increase or decrease the display size as desired (see below). A “back” button is also available at the top of each screen to return to the previous menu.

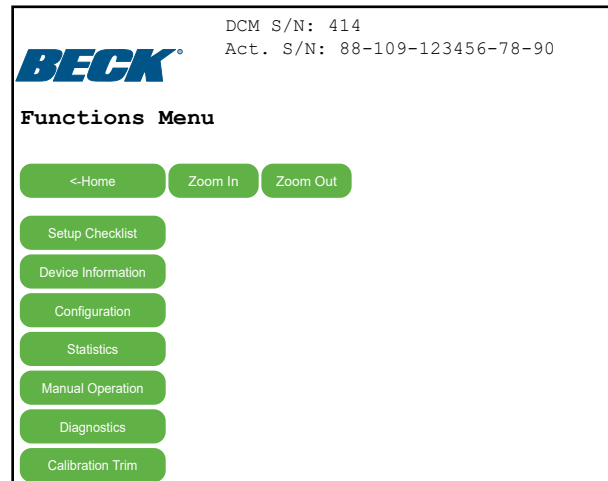

Some menus have real time data from the actuator and include a “Freeze Readings” button (see the “Home Menu” example at left. Pressing this button will freeze the data and prevent updates, which will allow the screen data to be copied. When in freeze mode, an “Allow Updates” button will appear. Pressing this button will allow the data to be updated in real time once again.

The following menu overview and descriptions provide a summary of the functions available through Wi-Fi communication. The menu system is structured to provide logical access to the functionality of the actuator, including:

A “Home” menu that provides basic, dynamic information about the actuator, as well as a path to the rest of the menu tree through the “Functions” menu.

A “Configuration” menu that allows access to editable parameters related to the following actuator functions: “General Setup”, “Position Sensor Setup”, “Demand Setup”, “Feedback Setup”, “Torque Setup” and “Communications”.

A “Diagnostics” menu provides a gateway to checking the actuator status as well as performing tests for troubleshooting, etc.

“Setup Checklist” is a convenient menu that provides a shortcut to allow parameters of the actuator to be quickly set without the need to go deeper into the menu structure.

Wi-Fi Communication Menu Overview

Home Menu***		1
• Functions		2
• Position	63.5%	
• Demand	63.6%	
• Loop(Dem)	14.172mA	
• Torque	48%	
• Temperature	87degF	
• Feedback	14.162mA	

Functions Menu		2
• Setup Checklist		3A
• Device Information		3B
• Configuration		3C
• Statistics		3D
• Manual Operation		3E
• Diagnostics		3F
• Calibration Trim		3G

BECK Wi-Fi COMMUNICATION MENU (SAMPLE VALUES SHOWN)

REFERENCE NUMBERS ARE SHOWN AT THE UPPER RIGHT CORNER OF EACH MENU BLOCK AND ARE RELEVANT TO THIS INSTRUCTION ONLY.

* THIS VALUE CAN BE EDITED.

** INDICATES AN ACTION.

*** THIS MENU IS DISPLAYED WHEN COMMUNICATION IS ESTABLISHED.

Setup Checklist Menu		3A
• Actuator S/N:88-109-189400-00-00		
• POS Calibration Wizard**		
• Drive Dir: CW*		
• Feedback: enabled*		
• Position Units: turns		
• MaxTravel: 4000 turns		
• Travel: 1000 turns*		
• Dem mA at 0%: 4.000*		
• Dem mA at 100%: 20.000*		
• Demand Curve: Linear*		
• Dem LOS Threshold mA: 3.200*		
• Dem LOS Mode: Stay in Place*		
• Dem LOS GTP Pos: 50.0%*		
• Fdbk mA at 0%: 4.000mA*		
• Fdbk mA at 100%: 20.000mA*		
• Fdbk Function: Linear*		
• Torque: enabled*		
• Torque Zero Null Level: 322TK*		
• Torque Constant: 526TK*		
• Torque Alarm Level: 105.0%*		
• OVT Stop: Keep Trying*		
• Torque Shutdown Level: 115.0%*		
• Stall Protection: enabled		
• Stall Time: 3600*		
• Temperature Units: degF*		
• Limit Switch: Accepted as normal*		
• Relay Functions Menu*		
• Relay Mask Menu*		
• RPM: 60.0*		
• Actuator Timing (sec): 3000		
• Power Phases (min required): 3		

Device Information Menu		3B
• Tag: BROWN_88*		
• Descriptor: 88Act17*		
• Message: 1stInstallGate*		
• Model#: 88-109		
• Actuator S/N:88-109-189400-00-00*		
• Date Installed: 11-NOV-2025*		
• Date Calibrated: 11-NOV-2025*		
• Date Setup: 11-NOV-2025*		
• Review		
• HART Poll Addr: 0*		
• DCM Software Rev: 1.03		
• Wi-Fi Display Rev: 1.01		

Statistics Menu		3D
• Starts: 356		
• Reversals: 228		
• Stalls: 0		
• OverTorques: 0		
• Pk Torque: 50%		
• TotRunTime: 162		
• High Temp: 89degF		
• Low Temp: 72degF		

Diagnostics Menu		3F
• Status		4G
• Tests		4H
• Shaft Load Profile		
• Alarm Setup		4I
• Real Time Clock*		
• Beck Command*		
• Event Log		4J

Configuration Menu		3C
• General Setup		4A
• Position Sensor Setup		4B
• Demand Setup		4C
• Feedback Setup		4D
• Torque Sensing Setup		4E
• Restore to Factory Cal*		
• Communication Setup		
• BPU Setup (N/A)		4F
• End-of-Travel LEDs*		

Manual Operation Menu		3E
• OpMode: FOLLOW*		
• Demand: 63.55%*		
• Reset Stall Alarm*		
• Return to Analog Control*		

Calibration Trim Menu		3G
• Loop (Dem): 4.0mA*		
• Feedback: 14.164mA*		
• Torque: 20%*		

General Setup Menu**4A**

- Drive Dir: CW*
- Set Position 0%*
- Set Position 100%*
- MaxTravel: 4000.0 turns
- Travel: 1000.0 turns*
- Stall Time: 2000*
- Stall Protection: enabled
- Limit Switch: Accepted as normal*
- Position Units: turns
- Temperature Units: degF*
- RPM: 60.0
- Actuator Timing (sec): 24.4
- Power Phases (min required): 3
- Additional Settings **5A**

Feedback Setup Menu**4D**

- Fdbk mA at 0%: 4.000mA*
- Fdbk mA at 100%: 20.000mA*
- Fdbk Direction: Increasing*
- Feedback: enabled*
- Fdbk Function: Linear*

Status Menu**4G**

- LED Status
- Operating Status
- Switch Status: 0x00
- Cal Buttons Status: 0x00_0x00
- Power Line Frequency: 60 Hz
- Inhibitors
- Status Message

Additional Settings Menu**5A**

- Overrides Polarity*

Position Sensor Setup Menu**4B**

- POS Calibration Wizard**
- Set Position 0%*
- Set Position 100%*

Torque Sensing Setup Menu**4E**

- Torque: enabled*
- OVT Stop: Keep Trying*
- Torque Alarm Level: 105.0%*
- Torque Shutdown Level: 115.0%*
- Torque Zero Null Level: 322TK*
- Torque Constant: 526TK*
- Present Sensor Reading: 330cnts

Tests Menu**4H**

- FB Out Test*
- Board Self-Test
- Identify Device**
- Board Reset**

Demand Setup Menu**4C**

- Dem mA at 0%: 4.000*
- Dem mA at 100%: 20.000*
- Demand Curve: Linear*
- Dem Curve Spcl **5B**
- Dem LOS Mode: Stay in Place*
- Dem LOS GTP Pos: 50.0%*
- Dem LOS GTP Delay (sec): 0*
- Dem LOS Threshold mA: 3.200*
- Demand Upper Range Limit mA: 21.0

Communication Setup Menu**4F**

- Demand Source: Analog/HART*
- Modbus Baudrate: 19200*
- Modbus Parity: EVEN*
- Modbus PollAddr: 246*
- Modbus FP Endian: Big*
- Modbus Scaling: 0 to 10,000*

Alarm Setup Menu**4I**

- Relay Functions Menu*
- Relay Mask Menu*

Event Log**4J**

- Event Log: View 20 Most Recent**
- Event Log: Download All**

Demand Curve Special Menu**5B**

- 1 X: 0.00, Y: 0.00*
- 2 X: 100.0, Y: 100.0*
- 3 X: inf, Y: inf*
- 4 X: inf, Y: inf*
- 5 X: inf, Y: inf*
- 6 X: inf, Y: inf*
- 7 X: inf, Y: inf*
- 8 X: inf, Y: inf*
- 9 X: inf, Y: inf*
- 10 X: inf, Y: inf*
- 11 X: inf, Y: inf*
- 12 X: inf, Y: inf*
- 13 X: inf, Y: inf*
- 14 X: inf, Y: inf*
- 15 X: inf, Y: inf*
- 16 X: inf, Y: inf*
- 17 X: inf, Y: inf*
- 18 X: inf, Y: inf*
- 19 X: inf, Y: inf*
- 20 X: inf, Y: inf*
- 21 X: inf, Y: inf*

Wi-Fi Communication Menu Descriptions

MENU DESCRIPTIONS

(See Wi-Fi Communication Menu Overview, page 26–27)

MENU 1 -- Home Menu

When communications are established, the Home Menu is displayed.

- Functions: Link to the menu.
- Position: The output shaft position displayed as a percent of range.
- Demand: The Demand signal displayed as a percent of range.
- Loop (Dem): The Demand signal measured in mA.
- Torque: The present torque value (%) as applied to the output shaft.
- Temperature: The ambient temperature of the DCM.
- Feedback: The output signal (mA) representing the present position of the output shaft.

MENU 2 -- Functions

From the Functions menu, any of the DCM menus can be accessed. The menus are organized categorically as follows: Setup Checklist, Device Information, Configuration, Statistics, Manual Operation, Diagnostics, and Calibration Trim.

MENU 3A -- Setup Checklist

The Setup Checklist provides a quick way for the user to setup the key items necessary for basic actuator operation without having to access any other menus.

MENU 3B -- Device Information

The Device Information menu provides information about the actuator. These useful information entries may be viewed and/or edited.

- Tag: An 8 character entry that can be used to identify a specific field device label.
- Descriptor: A 16 character field used to provide any description desired.
- Message: A 32 character field used to provide any message desired.

- Model#: Displays the model number of the actuator in which the DCM is installed.
- Actuator S/N: The Serial number as shown on the actuator nameplate. When configured, this will automatically change the actuator model number (see previous item).
- Date Installed: The installation date has no affect on actuator operation.
- Date Calibrated: The calibration date has no affect on actuator operation.
- Date Setup: The setup date has no affect on actuator operation.
- Review: Link to a single menu snapshot of the actuator configuration in a read-only format. This menu may help ensure that the DCM is configured as desired.
- DCM Software Rev: The revision of the DCM Software with which the Wi-Fi module is communicating.

MENU 3C -- Configuration

The Configuration menu serves as the gateway to the operating parameters that can be used to configure the actuator based on the desired operation.

- General Setup: Link to the menu.
- Position Sensor Setup: Link to the menu.
- Demand Setup: Link to the menu.
- Feedback Setup: Link to the menu.
- Torque Sensing Setup: Link to the menu.
- Restore to Factory Cal: Restores field-configurable parameters back to the settings in effect when the DCM was shipped from the factory.
- Communication Setup: Link to the menu.
- BPU Setup: N/A.
- End-of-Travel LEDs: Allows selection of the desired action for the End-of-Travel (E-O-T) LEDs. These actions include “E-O-T Red Enable”, “E-O-T Green Enable”, “E-O-T Yellow Enable”, “Red Toward 100%” or “Green Toward 100%”. The threshold for the Red and Green LEDs may also be changed.

MENU 4A -- General Setup

This menu sets actuator parameters. The parameter entries are as follows:

- Drive Dir: The direction the output shaft rotates (looking into the output shaft) in response to an increasing Demand signal.
- Set Position 0%: Sets the 0% travel position.
- Set Position 100%: Sets the 100% travel position.
- MaxTravel: The maximum available travel distance of the output shaft in turns.
- Travel: The number of turns of output shaft travel for 100% signal span (adjustable).
- Stall Time: The amount of time the motor will run (in seconds) before Stall Protection is initiated and power removed from the motor.
- Stall Protection: Will stop the motor when Stall Time value is reached.
- LimitSwitch: This entry defines if contacting a limit switch causes an alarm. Selections are: "Accepted as normal" or "Alert as alarm".
- Position Units: The numeric unit of measure for the output shaft position is set for turns. Value cannot be changed.
- Temperature Units: The unit of measure for temperature sensing. May be "degF" (Fahrenheit) or "degC" (Celsius).
- RPM: Revolutions Per Minute.
- Actuator Timing (sec): This is a fixed value calculated from RPM & Travel.
- Power Phases (min required): This value is set at 3. Value cannot be changed.
- Additional Settings: Link to the menu.

MENU 5A -- Additional Settings

- Overrides Polarity: Allows choice of polarity for the Control Override inputs: "CCW", "CW" and "STOP". Typically, these polarities are set to "APPLIED", so when the contact is closed, current causes a signal to be active in the actuator. Conversely, if a polarity is set to "OPEN", an open contact (no current) causes the signal to be active in the actuator. Note that only one polarity should be set to "OPEN" at any time, otherwise conflicting signals may result in the actuator not moving.

Wi-Fi Communication Menu Descriptions

MENU 4B -- Position Sensor Setup

This menu includes parameters from the contactless magnetic vector position sensor (also referred to as the "CPS") that the DCM interprets as voltage equivalents.

- **POS Calibration Wizard:** The recommended method for position calibration (see page 39).
- **Set Position 0%:** Sets the 0% position to match the present output shaft position. The 100% position will then be automatically offset based on the current travel setting.
- **Set Position 100%:** Sets the 100% position to match the present output shaft position. Also instructs the DCM to change travel span in relation to the 0% position. This does not change the 0% position.

MENU 4C -- Demand Setup

The parameters on this menu determine the range and characterization of the Demand signal. It also includes parameters that determine behavior when the Demand signal is absent.

- **Dem mA at 0%:** Sets and displays the signal value in mA that represents 0% Demand (default is 4.00 mA, minimum is 0.5 mA). This value should be set above "Dem LOS Threshold mA".
- **Dem mA at 100%:** Sets and displays the signal value in mA that represents 100% Demand (default is 20.00 mA, maximum is 21.00 mA). This value should be set below "Demand Upper Range Limit mA".
- **Demand Curve:** Determines the relationship between the Demand signal and the position of the output shaft. Typically set to "Linear", but may also be set to "Square", "SqRoot" or customized "Demand Curve Special".
- **Dem Curve Spcl:** Link to the "Demand Curve Special" menu.
- **Dem LOS Mode:** Sets the action that will take place if the Demand signal is lost. Options are: "Stay in Place", "Go to Position" and "Stay-No Alarm".
- **Dem LOS GTP Pos:** If the "LOS Mode" has been set to "Go to Position", this

defines where the output shaft will move (in percent of travel) during loss of Demand signal conditions.

- **Dem LOS GTP Delay:** Programmable delay (in seconds) for the actuator to move to the programmed Dem LOS GTP position after the DEM LOS condition starts. Default value is zero (no delay).
- **Dem LOS Threshold mA:** Sets the threshold (in mA) below which the Demand signal is considered lost. This value should be set below "Dem mA at 0%".
- **Demand Upper Range Limit mA:** This is the threshold (in mA) above which the Demand signal is considered invalid. The Demand alarm will activate until the signal is brought below this level. Set at 21.0 mA, this value is not editable.

MENU 5B -- Dem Curve Spcl

This menu allows setting of the Demand signal characterization curve.

MENU 4D -- Feedback Setup

This menu is where the Feedback signal related actuator parameters are set.

- **Fdbk mA at 0%:** The value of the Feedback signal (in mA) that corresponds to a 0% output shaft position. This value can range between 3.00 mA and 16.00 mA (default = 4.00 mA).
- **Fdbk mA at 100%:** The value of the Feedback signal (in mA) that corresponds to a 100% output shaft position. This value can range between 7.00 mA and 21.00 mA (default = 20.00 mA).
- **Fdbk Direction:** Allows feedback calibration selection for 0% to 100% **increasing** (standard) (4–20 mA) or **decreasing** (20–4 mA) feedback.
- **Feedback:** Enables or disables the Feedback signal.
- **Fdbk Function:** Allows a choice in the relationship between the Feedback output signal and the actual position of the actuator. Choices are: "Linear" and "Inverse of Dem".

MENU 4E -- Torque Sensing Setup

This menu is where the Torque related actuator parameters are set.

- Torque: Enables or disables torque sensing.
- OVT Stop: Enables or disables overtorque protection. In “Stop” mode, power will be removed from the motor if excessive torque is detected. “Keep Trying” mode will maintain power to the motor.
- Torque Alarm Level: Sets the value that, if exceeded, will cause an alarm (20–105% of actuator rating). Does not affect actuator performance.
- Torque Shutdown Level: Sets the output shaft torque that, if exceeded, will remove power from the motor (25–115% of actuator rating).
- Torque Zero Null Level: The torque sensor value that represents 0% output shaft torque. This value is unique for each actuator and may be found on a label inside the actuator.
- Torque Constant: The internal DCM signal span associated with the output shaft torque. This value is determined during manufacture and is noted on a label inside the actuator.
- Present Sensor Reading: Displays the current sensor reading in counts.

MENU 4F -- Communication Setup

This menu is where the type of control interface is selected and associated communication parameters are configured.

- Demand Source: May be set to “Analog” or “Modbus”.

Also, Modbus parameters including: Baudrate, Parity, Polling Address and data formats.

MENU 3D -- Statistics

This menu is where all the actuator’s stored operating statistics are available.

- Starts: The total number of motor starts.
- Reversals: The total number of times the motor has started in the direction opposite to the previous start.
- Stalls: The total number of times the stall time has been exceeded.
- OverTorques: The total number of times that a Torque Alarm was issued.
- Pk Torque: The highest recorded torque on the output shaft.
- TotRunTm: Total amount of time the motor has been powered (in seconds).
- High Temp: Highest temperature recorded in the DCM compartment (in degrees Fahrenheit or Celsius depending upon the temperature units setting in “General Setup”).
- Low Temp: Lowest temperature recorded in the DCM compartment (in degrees Fahrenheit or Celsius depending upon the temperature units setting in “General Setup”).

Wi-Fi Communication Menu Descriptions

MENU 3E -- Manual Operation

This menu is used to allow manual operation using Wi-Fi communications. There are three manual operation procedures available. **Caution: this setting can override the control loop.**

- Op mode: Selects the operating mode of the DCM: "FOLLOW", "HOLD", "DIRCW", "DIRCCW", "STAY" and "STOP". "FOLLOW" mode is the normal state of operation and allows DCM control in response to the input Demand signal. "HOLD" mode forces the DCM to position according to the Demand value (see "Demand", this menu). "DIRCW" mode forces the actuator to move CW. "DIRCCW" forces the actuator to move CCW. The "STAY" and "STOP" modes force the actuator to maintain its present position. Note that the Handswitch overrides all operating modes.
- Demand: This procedure sets the effective Demand signal. If "Op mode" is set to "HOLD", entering a valid value (-5% to 105%) will control the motor. If "Op mode" is set to "FOLLOW", the Demand signal is displayed (unless an alarm condition exists).
- Reset Stall Alarm: Pressing the "Update DCM" button, will reset normal actuator operation after a stall condition has caused the motor to shut down. Note that stall conditions can also be reset by simply reversing the input Demand signal or cycling the actuator AC power.

MENU 3F -- Diagnostics

Provides paths to menus and settings that allow investigation of actuator problems.

- Status: Link to the menu.
- Tests: Link to the menu.
- Shaft Load Profile: Displays the peak load (%) of CW and CCW movement for each of ten segments representing full travel of the actuator.
- Alarm Setup: Link to the menu.
- Real Time Clock: Used for time stamping the event log and does not affect actuator performance.

- Beck Command: Allows any Beck Serial command to be initiated by entering it into this field. Beck Serial commands are an alternate method for configuring the actuator and are described in the Beck 88-109 supplementary instruction manual (80-8801-10).
- Event Log: Link to the menu.

MENU 4G -- Status

This menu provides links to status displays that monitor the operational status of the actuator.

- LED Status: Lists the current state of all the actuator LEDs ("ON" or "OFF").
- Operating Status: Indicates whether or not ("ON" or "OFF") the actuator is operating outside of the "normal" range; including, "Demand Out of Limits", "Position Out of Limits", "Temp Out of Limits", "Torque Out of Limits", "Overtorque Stop", "Stall Timeout", "Feedback Loop Open" and "Under Voltage".
- Switch Status: Displays the status of the actuator switches as "ON" or "OFF". These switches include the CCW & CW limit switches; the Override CCW, CW & STOP switches; and Handswitch CCW, CW & AUTO.
- Cal Buttons Status: Displays the current status of the DCM pushbuttons as "ON" or "OFF", including Calibrate, Set Pos 100% & 0%, Set Dem 100% & 0%, Dir Select and Factory. "Use Network Def" is not applicable.
- Power Line Frequency: The power line frequency as measured by the DCM. Read only.
- Inhibitors: Allows viewing of DCM conditions as "ON" or "OFF" that are preventing the motor running in the CW or CCW direction. Note: "ON" indicates condition is blocking motor operation.
- Status Message: Displays a message based on highest priority of function, that shows the reason the actuator is or is not running. This is a dynamic function updated every few seconds.

MENU 4H -- Tests

This menu provides access to some routines that will help determine if the actuator is functioning properly.

- FB Out Test: Allows choice of the desired actions for the Feedback mA output, including “Set FB Out to 4 mA”, “Set FB Out to 20 mA”, “Set FB Out to chosen mA” - which also requires the chosen mA to be entered into the appropriate field, and “Set FB follow Position”.
- Board Self-Test: A built-in self-test runs continuously in the background.
- Identify Device: Pressing the “Rapid Blink” button causes the Power LED on the DCM to temporarily blink rapidly. This function ensures that the Wi-Fi is addressing the correct actuator.
- Board Reset: Pressing the “Update DCM” button will cause the DCM to reset to factory settings. Actuator control and Wi-Fi will temporarily be lost.

MENU 4I -- Alarm Setup

The Alarm Setup menu parameters allow modification of the behavior of the alarm outputs.

- Relay Functions: Allows the choice of which function will actuate which of the three relays, including “Relay Not Used”, “Relay Closes at Shaft Angle”, “Relay Opens at Shaft Angle”, “Relay Opens on Alarm” and “Relay Closes on Alarm”. If the relay action is angle dependent, the shaft position as a percentage may be set for each of the three relays.
- Relay Mask: Allows the choice of which alarms will actuate which of the three output relays. Each of the three relay masks is also shown as a hexadecimal value.

MENU 4J -- Event Log

- Event Log: View 20 Most Recent: When selected, will display the 20 most recent events.
- Event Log: Download All: When selected, will display all recorded events.

MENU 3G -- Calibration Trim

The Calibration Trim menu sets and displays actuator calibration values. **Note that changing the calibration trim can cause signal measurement difficulties if performed improperly.**

- Loop(Dem): Displays the Demand signal as measured at terminals (35 & 36). This value can be edited to trim the Demand to ensure accurate measurement of the analog signal. Demand can only be trimmed at 4.0 mA and 20.0 mA. When the Demand control loop signal is being overridden by a special mode of operation, the effective Demand will not correspond to the mA value.
- Feedback: Displays the mA signal and allows the signal to be adjusted to ensure an accurate 4 to 20 mA output as measured at terminals (37 & 38).
- Torque: Displays the load measured at the output shaft as a percentage of rated torque. This is also a shortcut to set the 0% torque parameter (“Torque Zero Null Level”) by removing load from the output shaft, then setting this value to “0”.

CONFIGURATION/CALIBRATION

NOTE: Your Beck actuator was shipped from the factory ready for installation; no electrical adjustments are required before placing it in operation. Each actuator is set up and calibrated to the specifications that were written into the equipment order. However, if optional mechanical position switches were ordered, they are preset by the factory outside of the operating limits of the actuator and must be reset by the customer for their specific requirements (see below).

MECHANICAL POSITION SWITCHES (OPTIONAL)

Actuators may be shipped with two over-travel limit switches and four auxiliary limit switches located in the position sensor compartment (see page 5 for location). The over-travel limit switches should be set just outside the full travel limits. Auxiliary switches may set as suggested on the Standard Over-travel Limit and Auxiliary Switch Settings diagram (see next page) or as needed depending upon the application.

The switches may be easily adjusted, if desired. Switches are operated by cams which are clamped onto the control shaft. Setting a switch involves positioning the cam so that it operates the switch at the desired point of actuator travel. In the following procedure, the use of a continuity meter is recommended to determine when the switch opens or closes. If such a meter is not available, it is possible to hear the switch click as the contacts open and close.



CAUTION

Do not attach the meter or attempt to move the switch cams until the actuator is disconnected from the line voltage and auxiliary switches are disconnected from external power sources.

SETTING OVER-TRAVEL LIMIT SWITCHES CW AND CCW

This procedure should be used to set the over-travel limit switches.

1. Remove the position sensor cover (1/2" wrench).
2. Use the electric Handswitch to drive the control shaft so that the CW switch cam screw is accessible. Using a 7/64" hex wrench, loosen the screw so that the cam is just snug on the shaft (see image, next page).

3. Move the output shaft to the desired CW limit.
4. Turn the Handswitch to the "STOP" position.
5. **Disconnect power from the actuator.**
6. Remove the terminal block cover (1/2" wrench).
7. Connect a continuity meter across terminals 2 (AC) and 17 (pulsed AC CW). Rotate the cam until the meter shows no continuity (switch contacts open, switch clicks).
8. Tighten the cam locking screw to 5 lb-in (0.56 N•m) torque.
9. Disconnect meter and ensure the Handswitch is in the "STOP" position.
10. Replace the terminal block cover and tighten the bolts to 10 lb-ft (14 N•m) torque.
11. Reconnect actuator power.
12. Rotate the actuator's output shaft in the CCW direction away from the CW travel limit. Note the direction of rotation on the lobe of the cam. The correct cam lobe motion is away from the switch lever with the switch lever on the lower part of the cam. If not correct, return to step 2 and reset the cam to the proper orientation.
13. Rotate the output shaft again to the desired CW travel limit. If the stopping point is reached, the switch is properly set.
14. Repeat instructions 2–13 for setting the CCW travel limit switch (noting that referenced directions of rotation should be opposite of those used for CW switch setting). When at Step 7, connect the continuity meter across terminals 2 (AC) and 18 (pulsed AC CCW).
15. When both switches have been properly set, ensure covers are replaced (tighten bolts to 10 lb-ft (14 N•m) torque).

SETTING AUXILIARY LIMIT SWITCHES

Suggested settings for the four auxiliary switches are shown in the diagram on the following page. The heavy line indicates a closed circuit. Follow these instructions to set the operating point for the auxiliary switches:

1. Remove the control end cover (1/2" wrench).
2. Use the electric Handswitch to drive the shaft so that the switch cam is accessible. Using a 7/64" hex wrench, loosen the screw so that the cam is just snug on the shaft.
3. Move the output shaft to the desired switch trip position.

4. Turn the Handswitch to the "STOP" position.
5. **Disconnect power from the actuator and switch terminals.**
6. Remove the terminal block cover (1/2" wrench).
7. Connect the continuity meter across the appropriate terminals (see the actuator wiring diagram under the terminal block cover (or the typical wiring diagram shown on page 14). Rotate the cam to operate the switch.
7. Tighten the cam locking screw to 5 lb-in (0.56 N•m) torque.
8. Disconnect the meter and replace the terminal block cover (tighten the bolts to 10 lb-ft (14 N•m) torque).
9. Reconnect power.
9. Move the actuator's output shaft in the desired direction to verify that the cam lobe moves away from the switch lever. If not correct, return to step 2 and reset the cam to the proper orientation.
10. When switches have been properly set, ensure covers are replaced (tighten bolts to 10 lb-ft (14 N•m) torque).

TYPICAL SETTINGS FOR OPTIONAL OVER-TRAVEL LIMIT AND AUXILIARY SWITCH SETTINGS

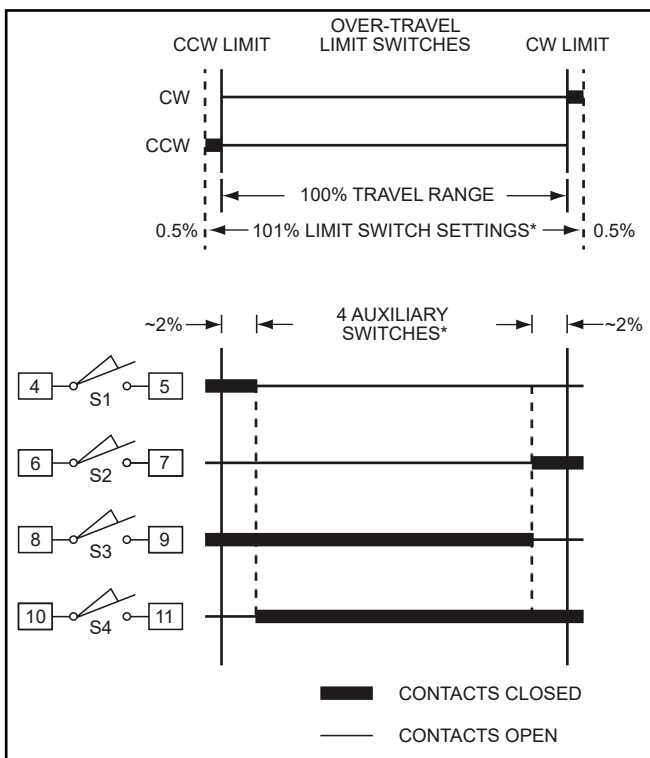

SWITCH CAM ADJUSTMENT

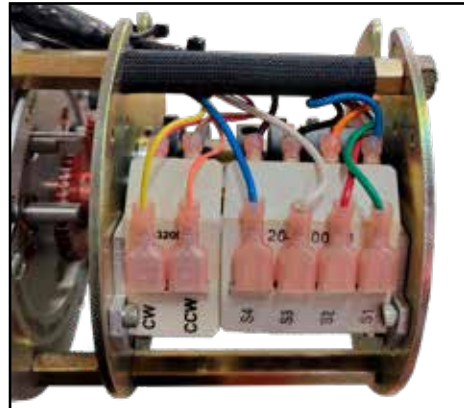

Control End
(Wiring side)

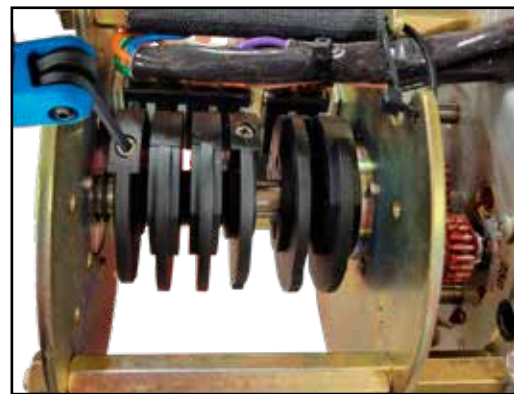

Control End
(Cam side) (shown - auxiliary switch 1
cam adjustment)

CONFIGURATION/CALIBRATION

CONFIGURING PROGRAMMABLE OUTPUT RELAYS

There are three configurable solid state relays in the 88-109 (see configurable relays 1–3 on the wiring diagram on page 14). Default settings for the relays are shown in the table below, but they may be custom-configured via Wi-Fi (Serial commands or Modbus may also be used for configuration - see separate instructions).

The three status output relays are also capable of a Soft Auxiliary Switch Mode, which configures the selected relay to turn on when the actuator output shaft position is outside of a specified percent of full travel.

The following table summarizes the relay capabilities:

TERMINAL CONNECTION	RELAY NAME	RELAY CAPABILITIES
Terminals 20 & 21	Relay 1 (SSR3) (120 Vac/dc max., 80 mA max.)	Defaults to a status alarm with mask 7FEEFEFF. The default polarity is normally closed (open on alarm).
Terminals 22, 23 & 24	Relay 2 (SSR1) (277 Vac/30 Vdc max., 10A max.)	Defaults to an alarm at the 0% limit. Customer determines polarity by wiring to the NC (Normally Closed) or NO (Normally Open) side of the switch.
Terminals 25, 26 & 27	Relay 3 (SSR2) (277 Vac/30 Vdc max., 10A max.)	Defaults to an alarm at the 100% limit. Customer determines polarity by wiring to the NC (Normally Closed) or NO (Normally Open) side of the switch.

ALARM MASK AND POLARITY SETUP

The alarm polarity controls the Normally Open (NO) vs. Normally Closed (NC) behavior of the activated relay and is configurable as follows:

- “0” sets the relay contact action to (NC).
- “1” sets the relay contact action to (NO).

The alarm mask is a bit array that selects which conditions activate the relay. A mask value of zero means that the specific alarm source is ignored. A mask value of one means that the relay will activate if the associated alarm is active.

The alarm mask for each relay is set using Wi-Fi (Serial commands or Modbus may also be used).

The alarm mask selection values are shown on the opposite page.

CONFIGURATION/CALIBRATION

DIRECTION OF OUTPUT SHAFT ROTATION

Rotation direction refers to the direction the output shaft of the actuator rotates in response to an increasing Demand input signal. The rotation is either clockwise (CW) or counterclockwise (CCW) as shown in the figure below. The rotation of the driven load determines the actuator rotation suitable for the application.

Unless otherwise specified at the time of order, the output shaft is factory set to rotate clockwise in response to an increasing Demand signal. The direction of rotation can be changed using one of the following methods.

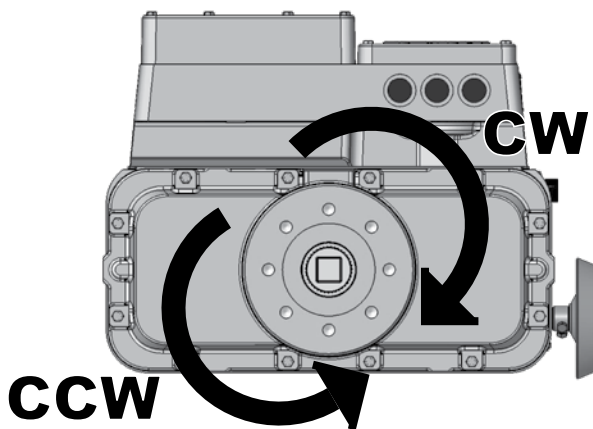

Pushbutton method

1. Press and hold the "CALIBRATE" pushbutton, then press the "DIR SEL" pushbutton until the (opposite) direction LED ("CW" or "CCW") is lit.

Ensure the actuator operates as desired.

* If the "ACKN" LED does not light, but the "POS" LED does light, the change was not accepted by the DCM.

NOTE: When any of the above procedures is performed, both the 0% and 100% positions are automatically set.

Wi-Fi method

Menu: General Setup

Submenu: Drive Dir *n*

Argument: *n* = CW or CCW

RESTORE FACTORY SETTINGS

All DCM's are shipped from the factory configured per customer instructions at the time of order. A complete copy of the factory configuration is stored on the DCM. You can revert to the factory settings at any time using the following method.

NOTE: When the factory settings are restored, the Operation Mode will not be changed for safety reasons. The operation mode should be set to "FOLLOW" for normal automatic operation.

Wi-Fi method

Menu: Configuration

Submenu: Restore to Factory Cal

Pushbutton method

The factory pushbutton is used in combination with the other pushbuttons to restore a limited selection of factory settings. The following chart describes the settings that can be restored:

Pushbutton Combination	Action
FACTORY + DEM 0%	Restore the Demand 0% mA value to the factory set calibration.
FACTORY + DEM 100%	Restore the Demand 100% mA value to the factory set calibration.
FACTORY + DIR SEL	Restore the actuator output shaft rotation direction to the factory set calibration.

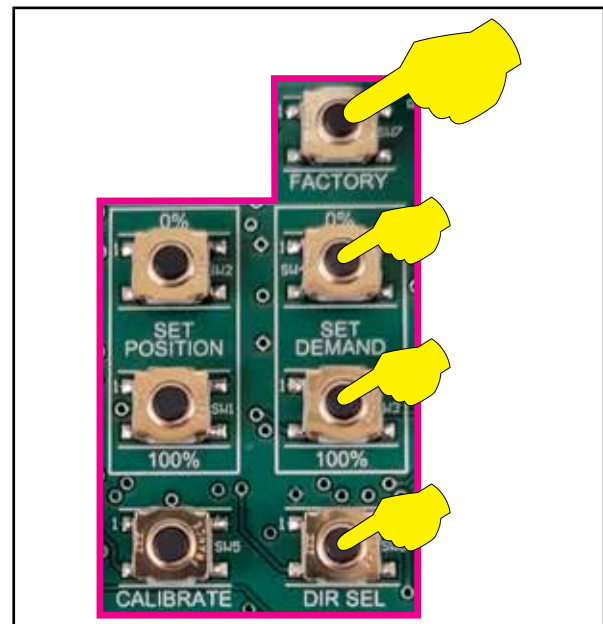

POSITION CALIBRATION AND TRAVEL (TURNS)

Travel is the number of turns of the output shaft between the 0% and 100% positions. Actuators are factory configured to order specifications.

It is possible to change the full travel of the actuator output shaft, if necessary. To change the turns comprising the travel range of the output shaft, first ensure position limits are properly set—see the following. Note: The takeoff gear (see page 16) may require adjustment if changing travel turns.

- 0% and 100% Position Calibration:** Drive the actuator to the new 0% and 100% positions. Activate the Calibration Wizard and use the Pushbutton or Wi-Fi method to set the new end points. 0% Position should always be set first.
- Changing Travel in Turns:** This allows the calibration to be changed without moving the actuator output shaft. Use the Wi-Fi method to set the desired full travel rotation in turns. The 0% position will remain the same, but the 100% position will change to accommodate the new travel setting.

NOTE: In addition to recalibrating the electronics, the CW / CCW over-travel switches should also be adjusted to open just beyond the new electronic limits; this ensures that manual operation with the Handswitch will not cause over-travel or create a stall condition.

POSITION CALIBRATION

Calibrate the 0% and 100% positions:

Pushbutton method

- Enter the Wizard by pressing the “SET POSITION 0%” pushbutton and the “SET POSITION 100%” pushbutton.
- Use the Handswitch to move the output shaft to the desired 0% position.
- Press and hold the “CALIBRATE” pushbutton then press the “SET POSITION 0%” pushbutton until the “ACKN” LED is lit.
- Use the Handswitch to move the output shaft to the desired 100% position.
- Press and hold the “CALIBRATE” pushbutton then press the “SET POSITION 100%” pushbutton until the “ACKN” LED is lit.
- Wizard Calibration complete. The actuator travel direction and number of turns have been set automatically.

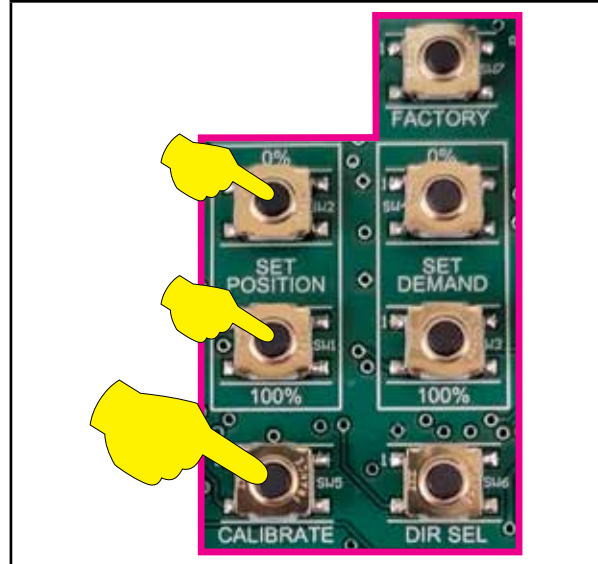

Wi-Fi method

- Ensure jumpers are set for Wi-Fi (see page 24).
- Set Handswitch to “AUTO”.

Menu: Functions

Submenu: Setup Checklist

Submenu: POS Calibration Wizard

Move to the desired 0% position:

- Select the “Start” icon.
- Select the “Go CW” or “Go CCW” icon.
- Select the “STOP” icon when desired 0% position is reached.
- Select the “Set Position 0%” icon.

Move to the desired 100% position by following steps 1–4 above, substituting 100% for 0%.

Wizard Calibration complete. The actuator travel direction and number of turns have been set automatically.

CHANGING TRAVEL (TURNS)

Wi-Fi method

Menu: General Setup

Submenu: Travel *n*

Argument: *n* = 4 to 4000

CONFIGURATION/CALIBRATION

DEMAND CALIBRATION

The DCM is designed to accept a 4–20 mA Demand signal. The input comes calibrated from the factory for the full range unless otherwise specified by the customer. It is not necessary to calibrate the Demand input when the actuator is installed; however, if the Demand needs to be calibrated to accommodate unusual operating conditions, two guidelines must be followed: First, the value for 0% must be greater than 0.5 mA and the value for 100% must be less than 21 mA. Second, the difference between 0% and 100% (minimum span) must be at least 4 mA. Use the following methods to calibrate Demand. Actuators may also be configured for split-range operation—contact the factory for details. Ensure that the Demand LOS threshold is set accordingly to prevent unnecessary alarm activation.

Calibrate the 0% and 100% Demand signal:

Pushbutton method

1. Ensure the Handswitch is in the “STOP” position. This will prevent the actuator from repositioning during this procedure.
2. Apply the desired 0% Demand input signal to the actuator (e.g., 4 mA for 4–20 mA signal).
3. Press and hold the “CALIBRATE” pushbutton, then press the “SET DEMAND 0%” pushbutton until the “ACKN” LED is lit.*
4. Apply the desired 100% Demand input signal to the actuator (e.g., 20 mA for 4–20 mA signal).
5. Press and hold the “CALIBRATE” pushbutton, then press the “SET DEMAND 100%” pushbutton until the “ACKN” LED is lit.*

*If the “ACKN” LED does not light, but the “DEM” LED does light, the calibration is out of acceptable range and was not accepted by the DCM. This is typically caused by trying to set 0% and 100% values too close together (i.e., less than 4 mA difference).

6. Turn the Handswitch to the “AUTO” position.
NOTE: The actuator may reposition.
7. Run the actuator through its full operational range to ensure proper response to the Demand input signal.

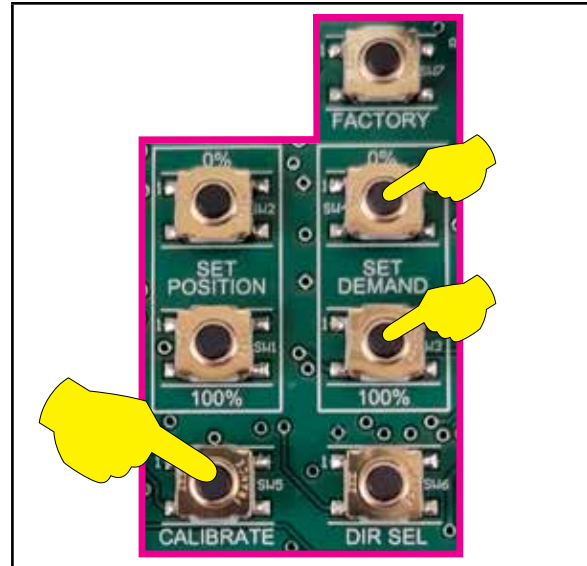

Wi-Fi method

Menu: Demand Setup

Submenu: Dem mA at 0% *n*

Argument: *n* = 4.0 to 16.0

Submenu: Dem mA at 100% *n*

Argument: *n* = 8.0 to 20.0

NOTE: Typical options above for 4–20 mA. The difference between Dem 0% and Dem 100% must be at least 4 mA. Typically, for a 4–20 mA signal, 0% is set at 4.0mA and 100% is set at 20.0mA.

LOSS OF DEMAND SIGNAL (LOS)

The DCM is capable of determining if the Demand input signal to the actuator is outside of an acceptable range. The DCM uses a configurable loss of signal (LOS) threshold to determine if the Demand signal falls below a minimum value. Unless otherwise specified in the original order, the factory-set threshold is 3.2 mA. When the DCM senses an LOS condition, an alarm will result, illuminating the “Demand” status indication LED. The actuator then responds according to the LOS setting. The DCM can be configured for one of two LOS actions:

1. **Stay in Place**—the actuator output shaft stays in place until the Demand signal returns to the acceptable range. This is the factory default.
2. **Go-to-Position**—the actuator output shaft will move to a preset position, designated in percentage of travel. For example, if the LOS action is set for 50%, the actuator output shaft will drive to the 12 mA position (based on a 4-20 mA span).

LOS parameters are configured as follows.



CAUTION

The following procedures could cause the actuator to reposition, which can adversely affect the process and cause potentially dangerous conditions.

Configure the LOS threshold:

Wi-Fi method

Menu: Demand Setup

Submenu: Dem LOS Threshold mA *n*

Argument: *n* = 3.2 mA

NOTE: Typical for 4–20 mA Demand signal.

Configure the LOS mode:

Wi-Fi method

Menu: Demand Setup

Submenu: Dem LOS Mode *n*

Argument: *n* = Stay in Place or
Go to Position

Configure the LOS position when Go-to-Pos is selected:

Wi-Fi method

Menu: Demand Setup

Submenu: Dem LOS GTP Pos *n*

Argument: *n* = 0.0% to 100.0%

Configure the delay time for the actuator to move when LOS is detected:

Wi-Fi method

Menu: Demand Setup

Submenu: Dem LOS GTP Delay *n*

Argument: *n* = seconds before response

CONFIGURATION/CALIBRATION

DEMAND CHARACTERIZATION CURVES

The DCM can be configured to interpret the applied Demand signal for linear or non-linear output shaft position response. Three predefined Demand signal response curves are available for use including: Linear, Square, and Square Root. A chart of each of these predefined responses is provided for your reference.

In addition to the three predefined characterization curves, the DCM also allows a custom user-defined curve (Curve Special) to be configured.

Change the Demand characterization curve:

Wi-Fi method

Menu: Demand Setup

Submenu: Demand Curve *n*

Argument: *n* = Linear or

SqRoot or

Special Curve or

Square

NOTE: Demand Curve leads to another submenu that allows selection from the arguments above.

DEMAND SIGNAL RESPONSE CURVES

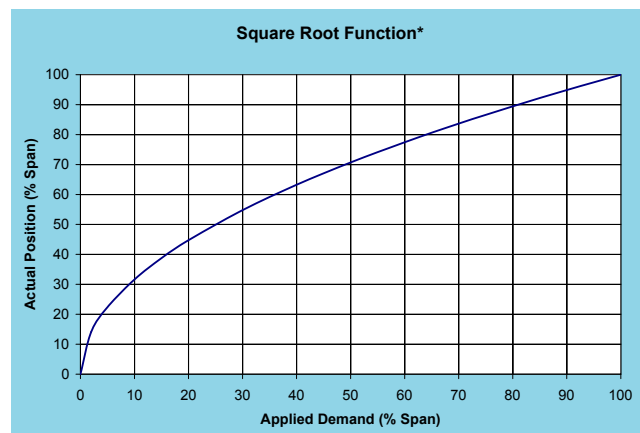
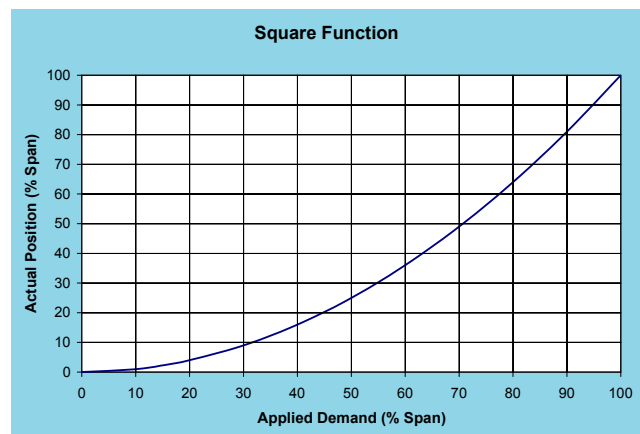
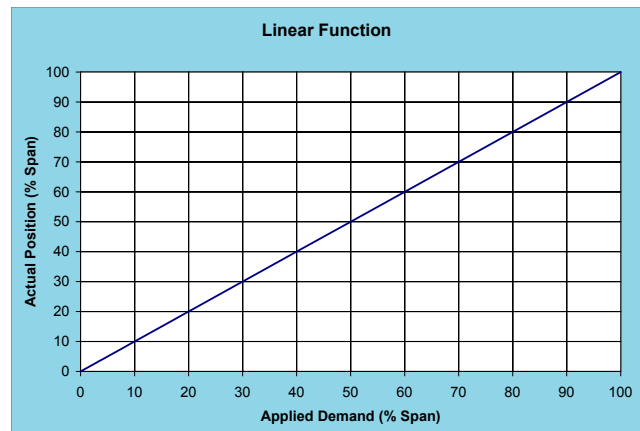

***NOTE**

Implementing a square root characterization creates extremely high gain when the Demand signal is below 10%; this causes instability and is unsuitable for control at this level. Do not apply this curve if the control loop may need to modulate at the lower range of travel.

USER-DEFINED CHARACTERIZATION

Special curves may be created from up to 21 segments, each of which has a node for a starting point and a node for an ending point. All 21 segments do not have to be used, but the used segments must be grouped together starting with segment 1. Segments cannot be skipped.

A node is a coordinate comprised of an X,Y point. When defining nodes, X-values and Y-values must increase as the node number increases. For example, the X-value and Y-value of node 2 must be higher than the X-value and Y-value of node 1. Nodes cannot be skipped. Always start at node 1.

Unless otherwise specified, the Special curve ships from the factory defined as a linear function (i.e., one segment beginning with node 1 at X = 0%, Y = 0% and ending with node 2 at X = 100%, Y = 100%). X-values are typically chosen to give a reasonable spacing in Y-values.

The customer may specify a custom characterization by entering X- and Y-value pairs to define line segments between 0% and 100%.

For example, the table at right uses 5 segments to approximate the square function (i.e., $y=x^2$). Segments 1 through 5 are needed, so nodes 1 through 6 are used.

The following method can be used to configure a user-defined characterization curve:

Change the user-defined characterization:

Wi-Fi method

Menu: Demand Setup

Submenu: Dem Curve Spcl

NOTE: Dem Curve Spcl leads to another submenu that allows selection of segments and input of X and Y values.

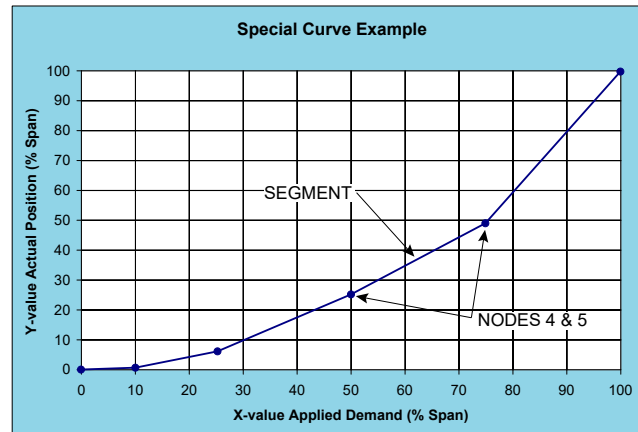

NODE	X-VALUE (DEMAND) % SPAN	Y-VALUE (POSITION) % SPAN
1	0%	0%
2	10%	1%
3	25%	6%
4	50%	25%
5	75%	49%
6	100%	100%

CONFIGURATION/CALIBRATION

POSITION FEEDBACK SIGNAL

The DCM provides a 4–20 mA analog output signal that represents the actuator output shaft position. The DCM monitors an internal position voltage from the position sensor, controls the actuator position, and sources a 4–20 mA signal to terminals 37 (–) and 38 (+). The Feedback will correspond with the 0% and 100% output shaft positions, as determined by the position calibration. **There is no need for separate Feedback calibration.**

The user has the option of enabling or disabling the position Feedback signal. The factory default configuration is Feedback enabled. When the Feedback is enabled, but not in use (i.e., not wired to a load) the "STAT" and "FB_OPEN" LEDs will illuminate. This status alarm is helpful in alerting the user to open Feedback wiring, but can be a nuisance when the Feedback is purposely disconnected or unused. Disabling the Feedback signal turns off the output and eliminates the status alarm. If Wi-Fi is not immediately available to disable the Feedback signal, you can apply a 250 ohm load resistor across the Feedback terminals 37 (–) and 38 (+) to simulate a Feedback loop and eliminate the alarm.

If desired, the milliamp position Feedback values for 0% and 100% positions can be configured differently than the respective standard factory calibration of 4 mA and 20 mA. A valid 0% position Feedback signal value can be configured anywhere in a 3–16 mA range, while a 100% signal value can be configured from 7–21 mA. The 100% milliamp value must exceed the 0% value by at least 4 mA.

The factory calibrated relationship between the position Feedback signal and the output shaft position is linear (i.e., 0% to 100% Feedback signal corresponds directly with 0% to 100% shaft position). This relationship is suitable for most applications; however, the Feedback to Demand relationship can be changed to compensate for characterized Demand signals. This relationship is called "Inverse Demand". Configuring this option allows the position Feedback signal to match the uncharacterized Demand signal rather than true output shaft position.

The following example assumes 4–20 mA Demand and position signals. If the Demand is set to a square characterization, then a 12 mA Demand corresponds to 25% position. If the position Feedback curve is set to linear, then Feedback at 25% is 8 mA. For some control systems, having the Demand at 12 mA and the Feedback at 8 mA may cause a deviation alarm. The Feedback curve can be set to the inverse of Demand so the Demand and Feedback match when the actuator is balanced. In this example, with Feedback set to "Inverse of Dem" and the output shaft position at 25%, the Feedback signal would be 12 mA.

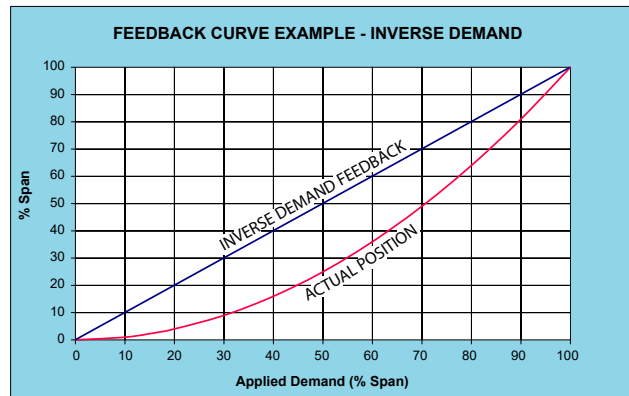
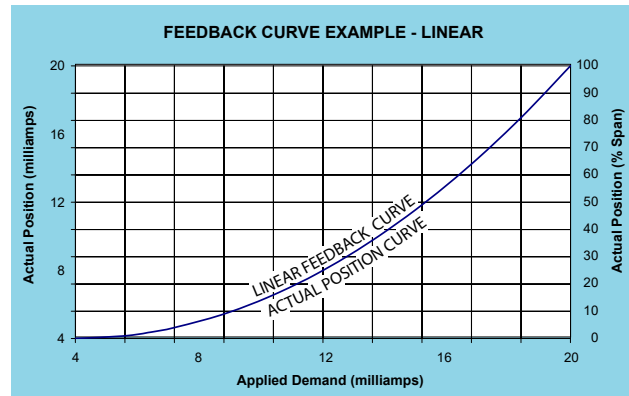

The following methods describe how to enable or disable position Feedback, set 0% and 100% milliamp values and select desired Feedback response:

Enable/disable the position feedback:

Wi-Fi method

Menu: Feedback Setup

Submenu: Feedback *n*

Argument: *n* = Enabled or Disabled

Set the feedback range lower and upper values:

Wi-Fi method

Menu: Feedback Setup

Submenu: Fdbk mA at 0% *n*

Argument: *n* = 3.0 to 16.0

Menu: Feedback Setup

Submenu: Fdbk mA at 100% *n*

Argument: *n* = 7.0 to 21.0

Set the feedback characterization curve:

Wi-Fi method

Menu: Feedback Setup

Submenu: Fdbk Function *n*

Argument: *n* = Linear or Inverse of Dem

TORQUE SENSING

Torque sensing measures the output torque of the actuator as a percentage of its rated torque capability. It provides a number of features including live torque measurement, overtorque alarm and overtorque protection.

Torque sensing is calibrated at the factory. There should never be a need to calibrate the torque measurement; however, if the DCM is ever replaced, the torque sensing calibration constants will need to be set. There are two calibration constants: Torque Zero Null and Torque Constant. These calibration settings are unique to the actuator and are recorded at the factory against the actuator Serial number. If the constants are needed to restore calibration, they can be found on a label on the back of the terminal cover or contact the factory by phone or email with the actuator Serial number to obtain these unique values.

Actuators are shipped from the factory with torque sensing and overtorque protection enabled. Torque sensing and overtorque protection can be either enabled or disabled, as desired. In addition, the torque alarm threshold value can be changed, as can the overtorque protection threshold.

Enable / disable torque sensing:

Wi-Fi method

Menu: Torque Sensing Setup

Submenu: Torque *n*

Argument: *n* = Enabled or Disabled

Set the torque zero null and constant values:

Wi-Fi method

Menu: Torque Sensing Setup

Submenu: Torque Zero Null Level *n*

Argument: *n* = Numeric value in counts TK

Menu: Torque Sensing Setup

Submenu: Torque Constant *n*

Argument: *n* = Numeric value in counts TK

LIVE TORQUE

The live torque measurement can be viewed on the display board through the window on the DCM compartment cover. Historical torque values can also be accessed (see supplemental instructions detailing Serial and Modbus communication interfaces).



OVERTORQUE PROTECTION

Overtorque protection protects both the actuator and driven equipment from damage when the torque exceeds the set threshold (configurable). Actuators normally ship from the factory with this feature enabled, but it can be disabled in the field using Wi-Fi.

The following method shows how to enable/disable the overtorque protection and how to set the threshold.

Overtorque protection:

Wi-Fi method

Menu: Torque Sensing Setup

Submenu: OVT Stop *n*

Argument: *n* = Keep Trying or Stop

NOTE: Enables or Disables overtorque protection. When overtorque is detected, this setting will either shut down the motor (stop) or direct the motor to continue running (keep trying).

CONFIGURATION/CALIBRATION

OVERTORQUE ALARM

When the torque reaches an alarm threshold (factory configured for 105% of rated torque), a status alarm will be initiated causing the “STAT” LED to illuminate. Disabling the torque sensor also disables the torque alarm. When the measured torque drops below the threshold the status alarm is automatically reset.

The following method allows the user to set the torque alarm threshold between 20% and 105%.

Set the overtorque alarm threshold:

Wi-Fi method

Menu: Torque Sensing Setup

Submenu: Torque Alarm Level *n*

Argument: *n* = percentage between 20% and 105%.

OVERTORQUE SHUTDOWN

When the measured torque reaches the shutdown level, power is removed from the motor. This threshold is factory-set at 115% of the rated torque, but can be adjusted

The following method allows the user to set the torque shutdown threshold between 25% and 115% of the actuator rating.

Set the overtorque shutdown threshold:

Wi-Fi method

Menu: Torque Sensing Setup

Submenu: Torque Shutdown Level *n*

Argument: *n* = percentage between 25% and 115%.

TEMPERATURE SENSING

DCMs are equipped with an internal temperature sensing circuit. The real-time temperature and the historical temperature extremes (low and high) are available (see supplemental instructions detailing Serial and Modbus communication interfaces).

Temperature units can be selected to show either Fahrenheit or Celsius.

An alarm condition initiates if the actuator’s real-time temperature falls outside the actuator rating (see “General Specifications”, page 4). The “STAT” LED and the “TEMPF” LED will light, and will automatically reset when the temperature is once again within the actuator rating.

Set temperature units:

Wi-Fi method

Menu: General Setup

Submenu: Temperature Units *n*

Argument: *n* = degF or degC

STALL PROTECTION

The DCM board provides protection for the actuator in the event of a stall. The DCM will calculate a suitable stall time based on the parameters of the actuator. Stall protection is activated when the actuator is unable to achieve the proper position within the calculated stall time due to a mechanical impediment or excessive load. The DCM is configurable to then shut off power to the motor or keep trying to move. When the stall condition occurs, the “STAT” LED will illuminate.

Resetting due to a stall condition is achieved by reversing the Demand signal or cycling the actuator power.

The stall protection feature can be enabled or disabled.

Enable / disable stall protection:

Wi-Fi method

Menu: General Setup

Submenu: Stall Protection *n*

Argument: *n* = Enabled or Disabled

NOTE: If enabled, the Stall Protection submenu allows selection of Stop or Keep Trying (as described above).

MAINTENANCE

MOTOR ASSEMBLY

The control motor is field replaceable, as are the motor brake and damper assemblies.

To replace the motor assembly:



WARNING

Electrical shock hazard. Disconnect power before proceeding.

Remove the existing motor assembly :

Remove the Electronics (DCM) compartment cover—(6) 5/16-18 captive hex head cap screws. Disconnect the motor connector on the DCM board (shown at the bottom of the image below). Disconnect the motor brake connector on the DCM board (shown at the top of the image below).

Remove the (4) 3/8-16 hex head motor assembly mounting screws (see image below). Carefully lift the motor assembly out of the actuator body.

Install the new motor assembly :

Connect the motor and motor brake to the appropriate connectors on the DCM board (see image at right).

Carefully slide the motor into the actuator body. If necessary, turn the Handwheel slightly to engage the pinion with the gearing.

Install the provided new (4) 3/8-16 hex head motor assembly mounting screws and torque to 20 lb-ft (27.1 N•m).

Replace the Electronics (DCM) compartment cover and torque screws to 10 lb-ft (13.6 N•m).

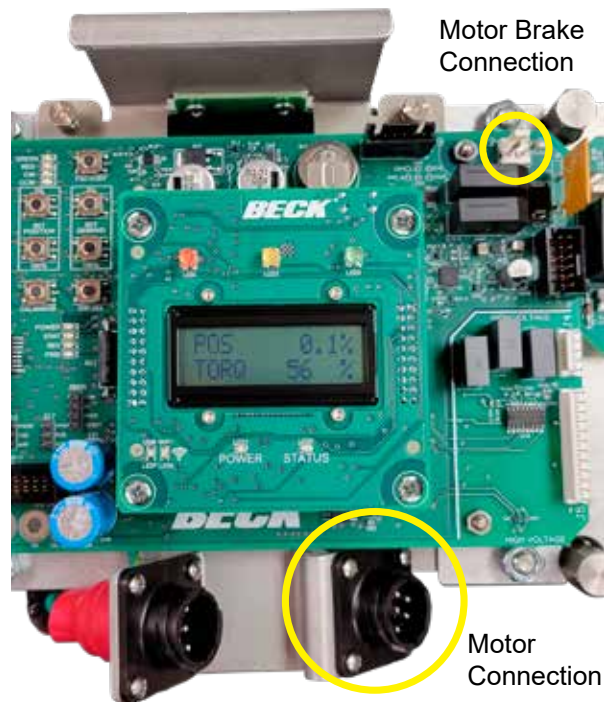

Motor Brake Connection

Motor Connection

LUBRICATION / GEARING

Periodic lubrication is not required.

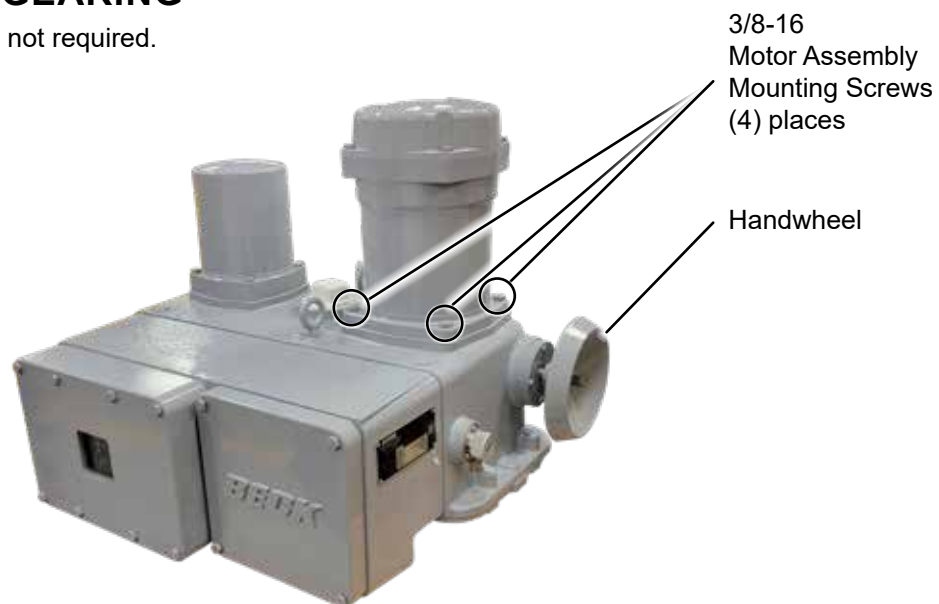

3/8-16
Motor Assembly
Mounting Screws
(4) places

Handwheel

MAINTENANCE

MECHANICAL POSITION SWITCHES (OVER-TRAVEL AND AUXILIARY)

Complete switch assemblies may be replaced. It is not possible to replace individual switches. To replace switch assemblies, follow the instructions below.



WARNING

Electrical shock hazard. Disconnect power before proceeding.

Remove the position sensor cover—(4) 5/16-18 captive hex head cap screws.

Remove the screws holding the appropriate switch assembly (CW/CCW or S1-S4) to the switch plate (top and bottom) and slide it out to the side.

Transfer the wires to the terminals of the replacement assembly, ensuring the correct wire is transferred to the correct replacement assembly terminal (wires have push-on lugs). Install the replacement assembly and note that it rotates around one screw to permit an adjustment of the cam-to-switch lever spacing and switch operating point. To set the switch, place a .030" (.75 mm) shim between the cam and switch lever (see photo at right). The switch lever should be on the low or minimum radius portion of the cam when setting the switches. Position the switch assembly so that the switch is just actuated. DO NOT overstress the switch lever. Tighten both screws to 10 lb-in (1.1 N•m) torque (using the rectangular washer to cover the gap in the mounting plate) and remove the shim. When properly adjusted, the cam-actuated switch lever will remain in contact with the cam throughout the actuator travel.

Replace the position sensor cover and torque screws to 10 lb-ft (13.6 N•m).

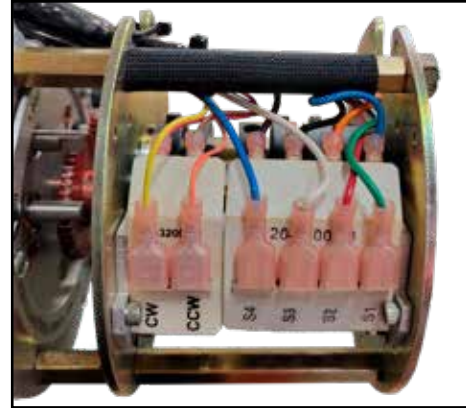

SWITCH REPLACEMENT KITS

Description	Part Number
Over-travel limit switch assembly (CW/CCW)	20-3200-06-KIT
Auxiliary limit switch assembly, (4) switches (S1/S2/S3/S4)	20-3200-08-KIT

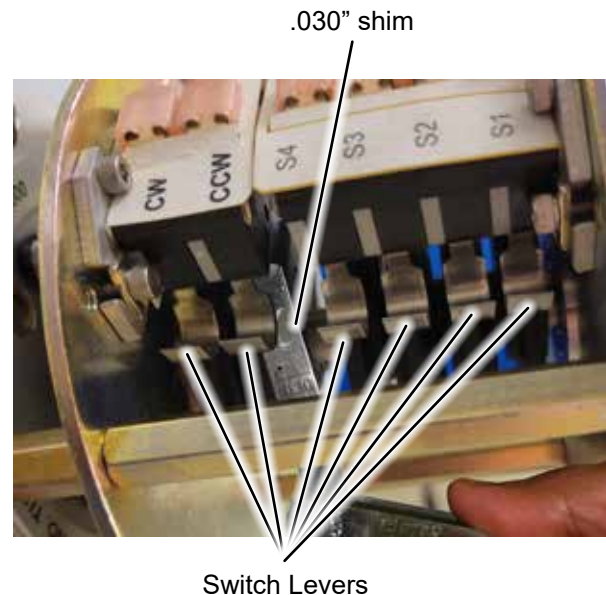

Switch Levers

THRUST MODULE ASSEMBLY

If the stem nut needs to be removed for machining or needs to be replaced, the stem nut must first be removed from the thrust module.

If the actuator is already installed on a valve, it must be removed per the instructions on page 12. Next, remove the thrust module assembly from the actuator.

Refer to the image at right during the following procedures.

Disassemble the thrust module:

1. Remove the (1) #10-32 pan head cross-recessed screw from the thrust module housing.
2. From the bottom of the thrust module assembly, push the bronze stem nut upwards out of the assembly.* The bearing retainer, accompanying O- and X-rings and upper thrust bearing will be removed with the stem nut.** *Note:* The lower thrust bearing may come out with the stem nut.
3. Remove bearing races from the stem nut.
4. The stem nut is now ready to be machined.

Reassemble the thrust module:

1. On each thrust bearing, identify the race with the smaller inner diameter (ID). Install the lower thrust bearing (if it was removed from the thrust module housing) with the smaller ID race on top (adjacent to the stem nut).
2. Install the stem nut into the lower bearing non-splined side first.
3. Install the upper thrust bearing with the smaller ID race on bottom (adjacent to the stem nut).
4. Install the bearing retainer. Top of bearing retainer should be flush or below adjacent surface of thrust module housing. Repeated light pressure may be needed to evacuate air buildup in O-ring seals and seat component fully.
5. Apply Loctite 222 or equivalent to the #10-32 pan head screw and install in the tapped hole in the thrust module housing. Tighten to 31 lb-in (3.51 N•m).

* The O-ring seal may prevent easy removal of the stem nut. It may be necessary to use a rubber mallet to gently tap the stem nut out of the assembly.

** The top of the upper thrust bearing assembly may get stuck in the bearing retainer, exposing the bearings in the assembly—this is not unusual and does not affect this procedure.

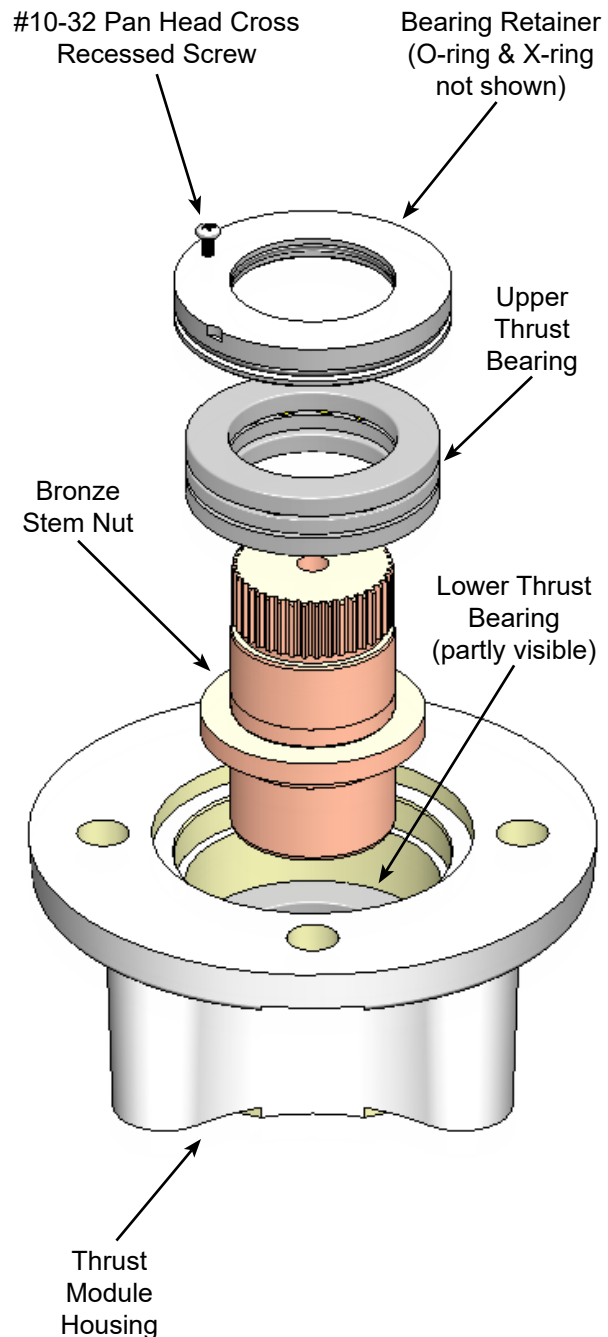

MAINTENANCE

DCM CHASSIS

Field repair of the DCM is not recommended. However, the DCM chassis may be replaced in the field as per the instructions below.



WARNING
Electrical shock hazard. Disconnect power before proceeding.

Remove the existing DCM chassis:



1. Remove the Electronics (DCM) compartment cover—(6) 5/16-18 captive hex head cap screws.
2. Disconnect all wire connectors, noting the locations for attachment to the new board (see image below).
3. Loosen the (4) captive standoffs (see image below) with a 7/16" ratchet/wrench.
4. Carefully pull the DCM chassis away from the actuator.

Install the new DCM chassis:

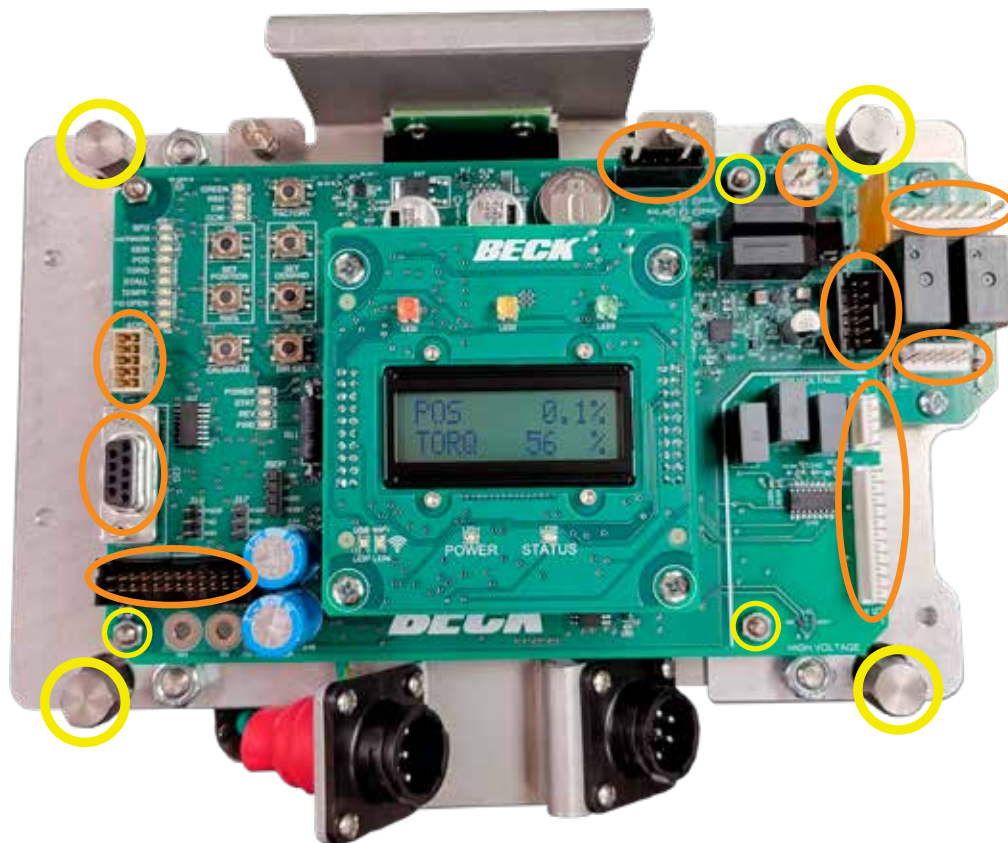
5. Ensure that all wiring is pulled off to the side. Carefully insert the new DCM chassis into the actuator, being careful not to pinch or displace any wiring. Note: The back of the chassis has two alignment holes to aid in properly positioning the chassis on the mounting surface within the actuator.
6. Tighten the (4) captive standoffs to 66 lb-in (7.5 N•m).
7. Reattach all wire connectors as noted in Step 2.
8. Replace the Electronics compartment cover (tighten screws (6) to 10 lb-ft [13.6 N•m]).
9. Restore power to the actuator and verify proper operation. Perform Demand and Position calibration, if necessary.



DCM BOARD & CHASSIS

-  = Standoffs (4 places)
 = Wiring Connections

FUSES

Fuses may be easily replaced in the field. Follow the instructions below.



WARNING

Electrical shock hazard. Disconnect power before proceeding.

1. Remove the Electronics (DCM) compartment cover—(6) 5/16-18 captive hex head cap screws.
2. Remove the fuse board from the chassis by loosening the two captive screws with a screwdriver (flat or Phillips). See images below.
3. Use the handle to pull the fuse board away from the chassis (it may be necessary to rock the board gently to detach it from the chassis).
4. Remove the fuse covers and inspect the fuses. Replace any blown fuse by pulling it out of the holder and pushing a new fuse (8A, 600 Vac/500 Vdc, slow-blow) into the holder.

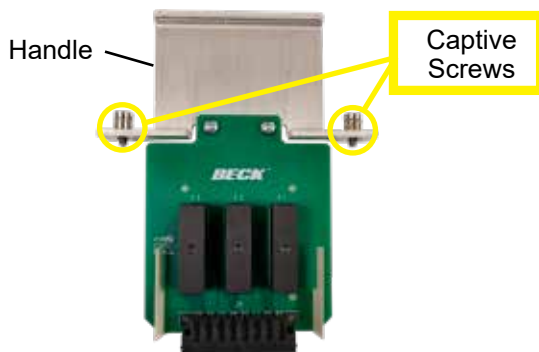
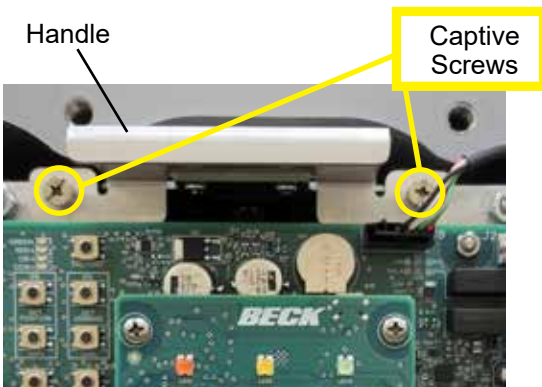

5. Replace the fuse board in the chassis by aligning the board with its connector and tightening the captive screws.
6. Replace the Electronics compartment cover (tighten screws (6) to 10 lb-ft [13.6 N•m]).

CONTACTLESS (MAGNETIC VECTOR) POSITION SENSOR (CPS)

The CPS is not field-repairable, however, it may be replaced in the field as per the instructions below. The actuator will require position recalibration using the “Travel (Turns)” instructions on page 39.



WARNING

Electrical shock hazard. Disconnect power before proceeding.

Remove the existing position sensing assembly (CPS) (refer to the image on the next page for part locations):

1. Remove the position sensor compartment cover—(4) 5/16-18 captive hex head cap screws.
2. If not equipped with the optional control end assembly (which includes mechanical position switches), skip to Step 4.
- 2a. Remove and retain the (3) 1/4-28 hex nuts securing the control end assembly to the position sensing assembly.
- 2b. Carefully pull the control end assembly straight off of the CPS assembly and set aside. Note: the switch wires and cable ties should remain attached.
3. Note the location of the takeoff gear (which of the five gear posts to which it is secured). Loosen the #6-32 socket set screw and remove (and retain) the takeoff gear.
4. Remove the (3) 1/4-20 socket head cap screws securing the CPS assembly to the actuator body.
5. Carefully pull the CPS assembly straight off the actuator body.

Install the new CPS assembly:

6. Carefully lower the new CPS assembly onto the actuator board-side down in the same orientation as the removed assembly.
7. Secure the new CPS assembly using the provided (3) 1/4-20 socket head cap screws (tighten to 66 lb-in [7.5 N•m]). Apply Loctite 222 or equivalent to the screw threads.
8. If not equipped with the optional control end assembly (which includes mechanical position switches), skip to Step 9.
- 8a. Replace the takeoff gear on the appropriate gear post. Tighten #6-32 socket set screw to 10 lb-in (1.1 N•m).

Continued

MAINTENANCE

CPS (cont'd)

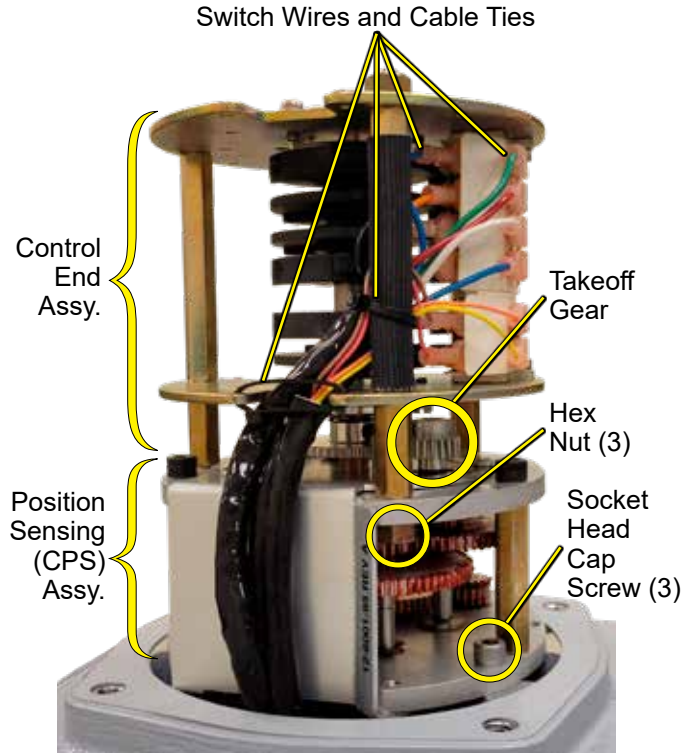

- 8b. Carefully reposition the control end assembly over the position sensing assembly, inserting the standoffs into the appropriate holes (see image above).
- 8c. Secure the control end assembly using the three 1/4-28 hex nuts from Step 2a. Tighten to 56 lb-in (6.3 N•m).
9. Recalibrate the actuator using the steps outlined in the "Travel (Turns)" section on page 39.
10. Reinstall the position sensor compartment cover—(4) 5/16-18 captive hex head cap screws. Tighten to 10 lb-ft (13.6 N•m).

HANDSWITCH



WARNING

Electrical shock hazard. Disconnect power before proceeding.

To replace the Handswitch assembly (refer to the following images):

Remove the existing Handswitch:

1. Remove power from the actuator.
2. Remove the wiring terminal compartment cover—(4) 5/16-18 captive hex head cap screws).
3. Remove the wiring terminal board screws—(11) #10-32 hex washer head Phillips. Note the location of the (2) green grounding screws and the (2) screws which also hold the electrical shock warning shield in place.
4. Carefully pull the wiring terminal board away from the actuator. The Handswitch assembly should now be visible in the area behind the terminal board.

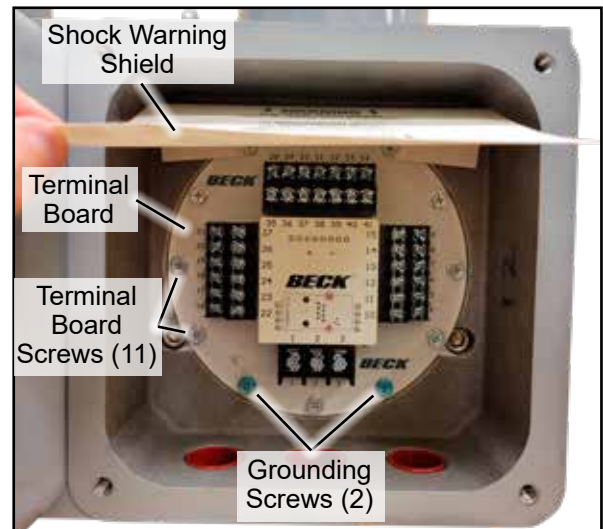
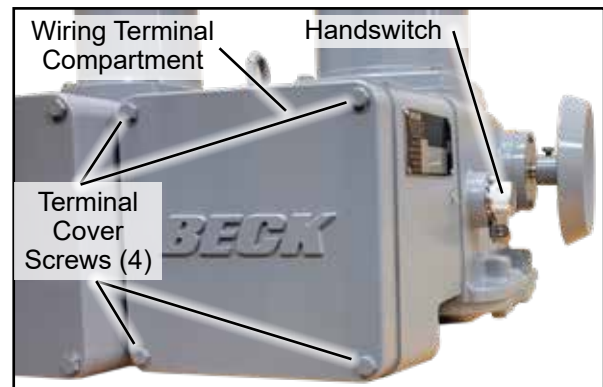

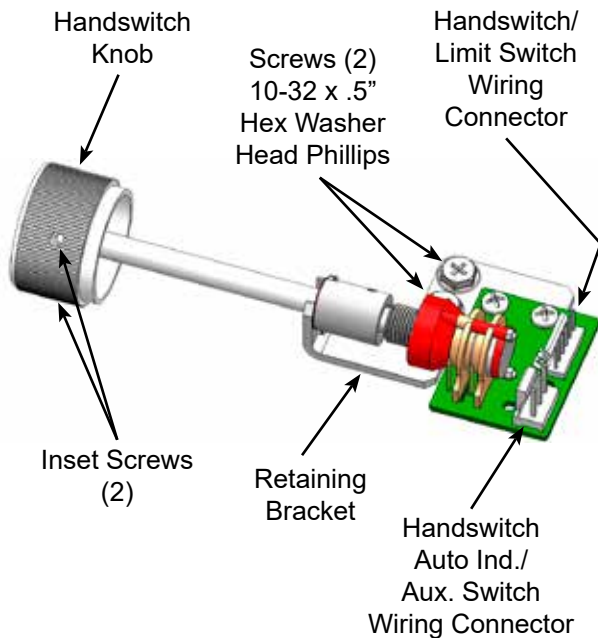
Handswitch Replacement (Cont'd)**HANDSWITCH ASSEMBLY**

5. Ensure the Handswitch knob is in a "STOP" position and loosen the two inset screws (5/64" hex wrench). Slide the knob off of the shaft.
6. Disconnect the (2) wiring connectors.
7. Remove the (2) 10-32 x .5" hex washer head Phillips screws securing the Handswitch assembly to the actuator. The Handswitch assembly may now be removed from the actuator.

Install the new Handswitch:

8. Insert the new Handswitch assembly into the actuator and align the screw holes in the retaining bracket with the mounting holes in the actuator.
8. Insert the (2) 10-32 x .5" hex washer head Phillips screws into the holes and tighten to 5 lb-ft (6.7 N•m).
9. Reattach the two wiring connectors.
10. From outside of the actuator, slide the Handswitch knob onto the shaft, ensuring that it is in the same STOP position as when it was removed. Tighten the two inset screws to 3 lb-ft (4 N•m).
11. Replace the terminal cover and tighten the (4) 5/16-18 captive hex head cap screws to 10 lb-ft (13.6 N•m).

NOTE: When the Handswitch is turned fully clockwise, "AUTO" should be indicated.

GASKETS AND O-RINGS

During routine service, inspect removed gaskets and O-rings for wear or damage. In order to protect internal components, worn or damaged gaskets and O-rings should be replaced, as described below. All user accessible gaskets and O-rings are available in the "Gasket Set" kit (see "SPARE PART KITS", next page).

The wiring terminal compartment, electronics (DCM) compartment and the position sensor (control end) compartment are sealed with silicone gaskets beneath the covers.

The motor assembly and motor brake assembly are sealed with O-rings beneath the covers.

To remove a gasket, scrape all of the old adhesive residue and any gasket material from the actuator body and cover. Replacement gaskets are self-adhering silicone rubber. Peel the backing off the replacement gasket and carefully apply to the actuator body, ensuring the gasket is flat and smooth.

Remove and discard old O-ring(s). When installing the new O-ring(s), ensure proper seating and apply a light layer of Parker Super O-Lube (SLUBE 884-2) or equivalent.

Tighten all covers with gaskets to 10 lb-ft (13.6 N•m).

Tighten motor assembly (to actuator) to 20 lb-ft (27 N•m).

Tighten motor brake assembly (to motor assembly) to 8 lb-ft (10.8 N•m).

TROUBLESHOOTING

SPARE PARTS

The table below lists customer replaceable spare parts and kits available for the 88-109 actuator.

SPARE PART KITS

Description	Part Number
Motor Replacement Kit	20-2205-88-KIT
Motor Brake Replacement Kit	20-8800-03-KIT
Motor Damper Replacement Kit	12-5540-41-KIT
DCM Chassis, 480V	12-8224-88-KIT
Position Sensor Assembly Replacement Kit	23-2488-05-KIT
Handswitch Assembly Replacement Kit	20-3302-02-KIT
Handwheel Assembly Replacement Kit	15-1062-68-KIT
Stem Cover Kit (3" x 6.5' tube with adaptor and cap)	20-3188-08
Overtravel Limit Switch Assembly (CW / CCW)	20-3200-06-KIT
Auxiliary Switch Assembly (S1–S4)	20-3200-08-KIT
Gasket Set Kit	20-0662-00-KIT

SPARE PARTS

Description	Part Number
Fuse, P.C. Board, Chassis, 8A, 600 Vac	11-1372-37
Stem Nut Blank, Thrust Module	14-9688-43
PVC Fitting, 3" Male to 3" Female Pipe Socket, Rising Stem Cover Adaptor	70-0442-12
PVC Stem Cap Fitting, Square Drive, 3" Male N.P.T.	70-0442-13

CONDITIONS	POSSIBLE CAUSES	CORRECTIONS
1. No DCM LEDs are illuminated.	<ul style="list-style-type: none"> a. No power is applied to the actuator. b. Incorrect power is applied to the actuator. c. DCM malfunction. d. Fuse cleared. 	<ul style="list-style-type: none"> a. Apply operating voltage to the appropriate terminals (see wiring diagram on inside of terminal cover). b. Verify correct voltage on actuator nameplate and ensure that it is applied at the operating voltage terminals. c. Replace DCM. d. Check the fuses located on the fuse board attached to the DCM (see page 18).
2. STAT LED is illuminated.	<ul style="list-style-type: none"> a. A status alarm is active. 	<ul style="list-style-type: none"> a. Check the status indication LEDs on the DCM. Continue troubleshooting based on the LEDs that are illuminated.
3. DEM LED is illuminated.	<ul style="list-style-type: none"> a. No Demand signal. b. Applied Demand signal is outside of configured range. c. Polarity of applied signal wires is reversed. 	<ul style="list-style-type: none"> a. Apply a Demand signal to terminals 36 (+) & 35 (-). b. Confirm Demand signal value by measuring DC voltage across DCM test points TP3(+) & TP2(-). Should be 1–5 Vdc for 4–20 mA applied signal. c. Correct the polarity of the applied control signal wires on terminals 36 (+) & 35 (-).
4. POS LED is illuminated.	<ul style="list-style-type: none"> a. Position sensor limit values are incorrect. b. Position sensor malfunction. c. DCM malfunction. 	<ul style="list-style-type: none"> a. Verify that the position sensor limit values are correct using the procedure outlined on page 53, beginning with Step 9. b. Replace position sensor. c. Replace DCM.
5. TORQ LED is illuminated.	<ul style="list-style-type: none"> a. Torque exceeding configured limit (typically over 115% of rated torque) is being applied to the output shaft. b. Torque Null and Torque Constant values are not set correctly. c. Torque cable loose or not connected to DCM. 	<ul style="list-style-type: none"> a. Eliminate cause of excessive torque. b. Locate Torque Null and Constant values and reset via Wi-Fi. c. Reconnect torque cable to DCM.
6. STALL LED is illuminated.	<ul style="list-style-type: none"> a. Actuator stalled—unable to achieve desired position within the configured “STALL TIME”. b. The configured stall time is less than the configured Max Travel Time. 	<ul style="list-style-type: none"> a. Eliminate the obstruction and reset the stall by reversing direction on your Demand signal or cycling the power. b. Configure the stall time to exceed the Max Travel Time via Wi-Fi.
7. TEMPF LED is illuminated.	<ul style="list-style-type: none"> a. The measured temperature at the DCM is outside of the normal operating range, typically -40° to 158° F. (-40° to 70°C.). 	<ul style="list-style-type: none"> a. Protect the actuator from extreme temperatures below or above the operating range to eliminate the alarm.
8. FB_OPEN LED is illuminated.	<ul style="list-style-type: none"> a. The position Feedback circuit current loop is not complete. b. The position Feedback is enabled, but not in use. 	<ul style="list-style-type: none"> a. Ensure the device measuring the 4–20 mA Feedback is properly terminated on terminals 37 (-) and 38 (+) and is applying a 0–800 ohm load resistance. b. Disable Feedback via Wi-Fi or terminate the Feedback loop by applying a 0–800 ohm load resistance across terminals 37 and 40.

TROUBLESHOOTING

CONDITIONS	POSSIBLE CAUSES	CORRECTIONS
9. UVOLT LED is illuminated.	<ul style="list-style-type: none"> a. The applied operating voltage is outside of the tolerance (+10%/-15%) of the nameplate operating voltage. b. A DCM fuse is open. c. A component failure has occurred on the DCM. 	<ul style="list-style-type: none"> a. Apply the correct operating voltage to the actuator per the voltage stamped on the nameplate. b. Replace the open fuse, see page 18. c. Replace the DCM.
10. All LEDs are illuminated or flashing.	<ul style="list-style-type: none"> a. A component failure has occurred on the DCM. 	<ul style="list-style-type: none"> a. Replace the DCM.
11. FWD or REV LED is illuminated, actuator is not moving, and there are no other status alarms.	<ul style="list-style-type: none"> a. Handswitch is in the STOP position. b. CW or CCW limit switch is open. 	<ul style="list-style-type: none"> a. Turn the Handswitch to the AUTO position. b. Verify limit switch is set outside of electrically calibrated limits & readjust or replace, if necessary.
12. Actuator will not hold position with Handswitch in STOP.	<ul style="list-style-type: none"> a. Motor brake failure. 	<ul style="list-style-type: none"> a. Replace motor brake assembly.
13. Actuator POWER LED is flashing, but does not respond to Demand signal, Handswitch or override terminals.	<ul style="list-style-type: none"> a. The STOP terminal (31) is connected to the common terminal (28). b. The safety shutoff circuit is damaged. c. The Handswitch is damaged. 	<ul style="list-style-type: none"> a. Remove the connection from terminal 31 to terminal 28. b. Contact the factory. c. Replace the Handswitch.
14. Position Feedback signal at terminals 37 and 38 remains constant or is erratic.	<ul style="list-style-type: none"> a. The position feedback circuit on the DCM is damaged. 	<ul style="list-style-type: none"> a. Replace the DCM.
15. POWER LED is pulsing bright to dim.	<ul style="list-style-type: none"> a. This is normal and indicates the processor is functioning. 	<ul style="list-style-type: none"> a. No action required.
16. Output shaft rotates opposite of desired direction when applying a 4–20 mA Demand signal.	<ul style="list-style-type: none"> a. The rotation direction is incorrectly configured. 	<ul style="list-style-type: none"> a. Configure the rotation direction using the pushbuttons or Wi-Fi.

NOTES

INDEX

Application Reviews	59	Product Demonstrations	59
Configuration/Calibration	34–46	Restore Factory Settings	38
Contactless Position Sensor	16	Safety Precautions	10
Demand Calibration	40	Services	59
Demand Characterization Curves	42–43	Site Surveys	59
Digital Control Module (DCM).....	17–22	Spare Parts.....	54
Notification LEDs	20	Specification Writing	59
Overview LEDs	20	Stall Protection	46
Pushbutton Controls	21	Start-up	15
Setup and Configuration Interfaces	19	Storage Information	10
Signal Test Points	22	Table of Contents.....	3
Status Indication LEDs	21	Temperature Sensing	46
Direction of Output Shaft Rotation.....	38	Torque Sensing.....	45–46
Electronics	16–22	Live Torque	45
General Specifications.....	4	Overtorque Alarm	46
Handswitch (Lockable)	11, 52–53	Overtorque Protection	45
How to Obtain Service	59	Overtorque Shutdown.....	46
Installation	12–14	Travel Turns (Degrees).....	39
Electrical	13	Change Travel	39
Mechanical	12	Troubleshooting	54–56
Valves	12	Warranty	59
Wiring	14	Wi-Fi	23–33
Introduction	2	Communication Interface.....	23–25
Loss of Demand Signal (LOS).....	41	Communication Menu Descriptions.....	28–33
Mechanical Position Switches	34–35	Communication Menu Overview.....	26–27
Maintenance	47–53		
DCM	50		
Fuses	51		
Gaskets and O-rings.....	53		
Handswitch	52–53		
Lubrication/Gearing	47		
Motor Assembly	47		
Mechanical Position Switches	48		
Position Sensor	51–52		
Spare Parts.....	54		
Thrust Module Assembly	49		
Outline Dimension Drawings	6–7		
Output Relays (Configuring).....	36		
Position Feedback Signal	44		
Position Sensor	16, 51–52		
Power Quality	13		
Precautionary Information	10		

SERVICES

PRODUCT DEMONSTRATIONS

Each of Beck's Sales Engineers has access to a complete set of actuator models so that he can demonstrate virtually any of their features at your location. In order to arrange to see a Beck actuator in your plant or office, contact Beck's Sales Department.

SITE SURVEYS

Beck Sales Engineers are available to discuss your process control requirements. Often a visit to your location is the best way to gain a thorough understanding of your needs, in order to meet them most accurately and completely.

Mounting hardware, torque requirements, linkage, control signal information, and optional equipment can be analyzed most effectively at the work site. Beck's analysis at the job site can help ensure that specifications are accurate, especially in the case of complex applications.

APPLICATION REVIEWS

By sharing your needs with a Beck Sales Engineer you can take advantage of the best application advice for the type of control you need.

This review will yield a better understanding of the versatility of Beck actuators for your installations, as well as complete details on options and accessories to make the process as effective as possible.

SPECIFICATION WRITING

Beck provides specification writing assistance in order to help you specify and order the right actuators for your applications. Beck Sales Engineers will work with you to make it easier for you to obtain the proper equipment and give you confidence that no details are overlooked.

HOW TO OBTAIN SERVICE

Factory repair of actuators or subassemblies is available for both normal and emergency service. To assure prompt processing, contact the factory to receive a Returned Material Authorization (RMA) number. If a repair estimation is desired, please send the name and phone number of your contact for service authorization. It is helpful to include a description of the work desired with the shipment or, in the event of a problem, the malfunction being experienced.

THREE YEAR LIMITED EQUIPMENT WARRANTY

Beck warrants to Buyer that: (i) for a period of 3 years from the date of shipment, the Equipment manufactured by Beck shall materially conform to Beck's published standard specifications in effect as of the date of shipment; and (ii) the Beck Equipment will be free from defects in materials and workmanship. This warranty does not apply to normal wear and tear, or where Beck Equipment failure is a result of improper installation, improper storage, misuse or improper maintenance, or water ingress related to Buyer or its agents failing to apply the stated torque requirements to fasteners when attaching covers or failing to replace temporary conduit plugs as stated in the installation instructions, or entry through conduits.

During the Limited Warranty Period, Buyer shall notify Beck of any alleged warranty claim within 30 days from the date Buyer discovers, or upon reasonable inspection should have discovered, such alleged claim (but in any event prior to the end of the Limited Warranty Period), and Buyer shall return the Beck Equipment in question, at Buyer's expense, to Beck for evaluation, in compliance with the terms stated in the "Return of Equipment" article in the Sales Contract. If Beck determines that the Beck Equipment fails to conform to the limited warranty, then, at Beck's sole discretion and its expense (subject to Buyer's conformity with the warranty), Beck will either: (i) repair or replace the Beck Equipment, without charge, at Beck's factory, or (ii) refund the purchase price of such Beck Equipment, less any applicable discounts, rebates, or credits. In no event will Beck's liability exceed the contract price actually paid for such Beck Equipment subject to a warranty claim. Beck makes no warranty, express or implied, with respect to any Buyout Item. This limited warranty is not transferable or assignable to any transferees of the Beck Equipment.

THIS WARRANTY IS EXPRESSLY IN LIEU OF ANY OTHER EXPRESS OR IMPLIED WARRANTY, INCLUDING IMPLIED WARRANTIES OF MERCHANTABILITY AND FITNESS FOR A PARTICULAR PURPOSE, AND ALL OTHER OBLIGATIONS OR LIABILITIES OF BECK. BUYER ACKNOWLEDGES THAT: (i) BECK HAS MADE NO INDEPENDENT INVESTIGATION OF THE SUITABILITY OF THE EQUIPMENT FOR BUYER'S INTENDED USE OR EXISTING SYSTEMS; AND (ii) BUYER HAS NOT RELIED UPON ANY REPRESENTATION OR WARRANTY MADE BY BECK OR ANY OTHER PERSON ON BECK'S BEHALF, EXCEPT AS SPECIFICALLY PROVIDED IN THE SALES CONTRACT. THIS SECTION SETS FORTH BUYER'S SOLE AND EXCLUSIVE REMEDY FOR ANY BREACH OF THE LIMITED WARRANTY SET FORTH IN THIS SECTION.

A 100% EMPLOYEE OWNED COMPANY

BECK

~ founded 1936 ~

SINCE 2021



HAROLD BECK & SONS, INC.

11 TERRY DRIVE • NEWTOWN, PENNSYLVANIA 18940 • USA

PHONE: 215-968-4600 • FAX: 215-860-6383 • E-MAIL: sales@haroldbeck.com

www.haroldbeck.com

Made in USA

